



Chipsmall Limited consists of a professional team with an average of over 10 year of expertise in the distribution of electronic components. Based in Hongkong, we have already established firm and mutual-benefit business relationships with customers from,Europe,America and south Asia,supplying obsolete and hard-to-find components to meet their specific needs.

With the principle of “Quality Parts,Customers Priority,Honest Operation,and Considerate Service”,our business mainly focus on the distribution of electronic components. Line cards we deal with include Microchip,ALPS,ROHM,Xilinx,Pulse,ON,Everlight and Freescale. Main products comprise IC,Modules,Potentiometer,IC Socket,Relay,Connector.Our parts cover such applications as commercial,industrial, and automotives areas.

We are looking forward to setting up business relationship with you and hope to provide you with the best service and solution. Let us make a better world for our industry!



## Contact us

Tel: +86-755-8981 8866 Fax: +86-755-8427 6832

Email & Skype: info@chipsmall.com Web: www.chipsmall.com

Address: A1208, Overseas Decoration Building, #122 Zhenhua RD., Futian, Shenzhen, China



DO NOT SCALE FROM THIS PRINT

ALL DIMENSIONS ARE REFERENCE  
(SEE T-C114-XXXX-X FOR CONTROLLING PRINT)

DESIGNED & DIMENSIONED  
IN MILLIMETERS

TC114-XXXX-X-X

LEAD STYLE  
-2830: 28 & 30 AWG

PACKAGING SPECIFICATION  
-S: STRIP (15 TERMINALS)  
-M: MINI REEL (1K - 5K TERMINALS)  
-R: REEL (30K TERMINALS)

PLATING SPECIFICATION  
-L: 10µ" LIGHT GOLD IN CONTACT AREA, B.A.T. ON TAIL

CARRIER SPECIFICATIONS

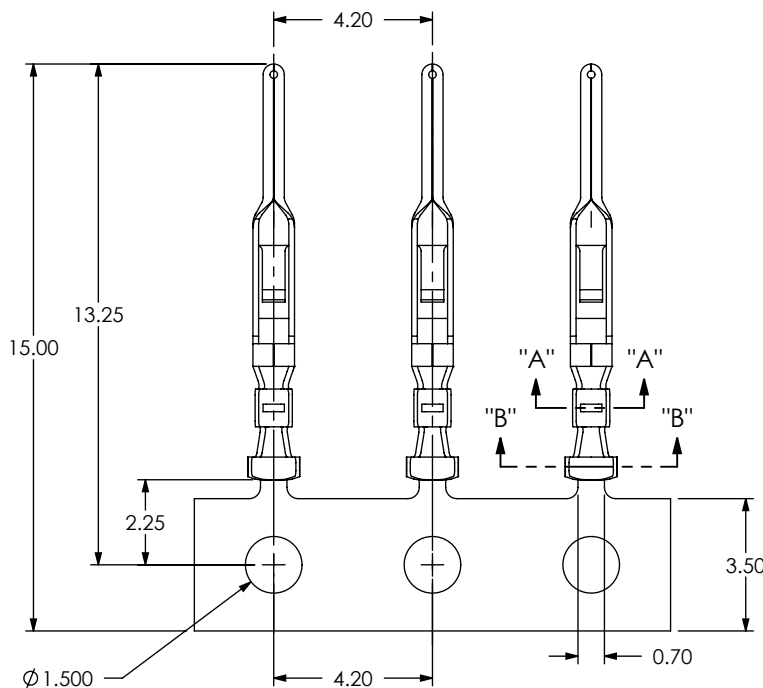
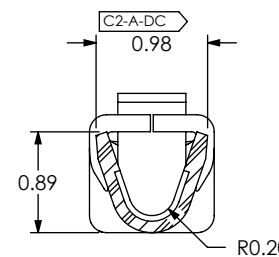
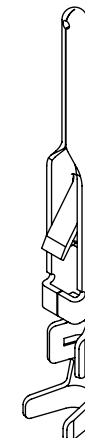
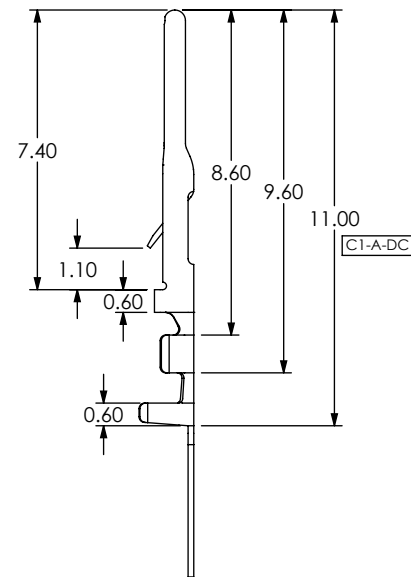
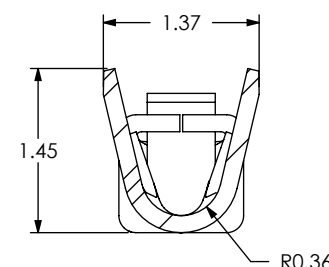

FIG 1  
TC114-2830-X-X SHOWN



SECTION "A"- "A"  
SCALE 15 : 1



SECTION "B"- "B"  
SCALE 15 : 1

NOTES:

1. PLATED T-C114 PARTS TO BE PULLED, PLATING OPTION CONFIRMED, AND  
-S (STRIP): 15 ±0 PCS POSITIONED AS SHOWN IN A SAMTEC TUBE.  
-M (MINI REEL): 1,000 - 5,000 +300/-0 PCS POSITIONED AS SHOWN ON SAMTEC REEL WITH VIEWPORTS.  
-R (REEL): 30,000 +300/-0 PCS POSITIONED AS SHOWN ON SAMTEC REEL WITH VIEWPORTS.
2. LABEL SHOULD INCLUDE PLATING CALLOUT AND BE PLACED ON REEL AS SHOWN, AND PLACE AS SHOWN.
3. MAXIMUM NO OF SPLICES PER REEL:  
-M (MINI REEL): 1 SPLICES ARE NOT TO BE CONNECTED. NUMBER OF SPLICES TO BE MARKED ON EACH REEL.  
-R (REEL): 2 SPLICES ARE NOT TO BE CONNECTED. NUMBER OF SPLICES TO BE MARKED ON EACH REEL.
4. REELED PARTS TO BE INTERLEAVED WITH PAPER BETWEEN EACH LAYER OF PARTS. ONE SPLICE IN INTERLEAF ALLOWED PER REEL AND TO BE SECURELY CONNECTED.
5. OUTER WRAP SHALL RECEIVE:  
-M (MINI REEL): HMS1015C-24MM PROTECTIVE REEL BAND.  
-R (REEL): RB-24-1.00-P PROTECTIVE REEL BAND.
6. DUE TO PLATING REQUIREMENTS CONTACT SAMPLES MAY BE REMOVED INTERMITTINGLY FROM THE CARRIER RESULTING IN SMALL GAPS BUT DOES NOT AFFECT FINAL PIN COUNT.

UNLESS OTHERWISE SPECIFIED,  
DIMENSIONS ARE IN MILLIMETERS.  
TOLERANCES ARE:  
DECIMALS ANGLES

PROPRIETARY NOTE

THIS DOCUMENT CONTAINS INFORMATION CONFIDENTIAL AND PROPRIETARY TO SAMTEC, INC. AND SHALL NOT BE REPRODUCED OR TRANSFERRED TO OTHER DOCUMENTS OR DISCLOSED TO OTHERS OR USED FOR ANY PURPOSE OTHER THAN THAT WHICH IT WAS OBTAINED WITHOUT THE EXPRESSED WRITTEN CONSENT OF SAMTEC, INC.



520 PARK EAST BLVD., NEW ALBANY, IN 47150  
PHONE: 812-944-6733 FAX: 812-948-5047  
e-Mail: info@SAMTEC.com code 55322

MATERIAL: DO NOT SCALE DRAWING SHEET SCALE: 6:1  
PHOS BRONZE  
THICKNESS: 0.15±0.01

DESCRIPTION:  
ACCLIMATE DISCRETE WIRE TERMINAL

DWG. NO.  
TC114-XXXX-X-X

BY: TRAVIS N 11/26/2013 SHEET 1 OF 2

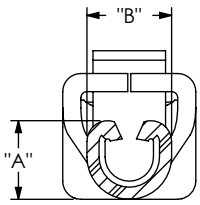

WIRE CRIMP  
SCALE 16:1



INSULATION STRIP LENGTH

TABLE 1						
P/N	AWG	STRANDS/AWG	INSULATION OD	"A"	"B"	"C"
T-C114-2830-X	30	7/38	0.737[.0290]- 0.940[.0370]	0.406 [0.0160]	0.813 [0.0320]	1.905 [0.0750]
	28	7/36		0.457 [0.0180]	0.813 [0.0320]	

FIG 2  
RECOMMENDED PROCESSING

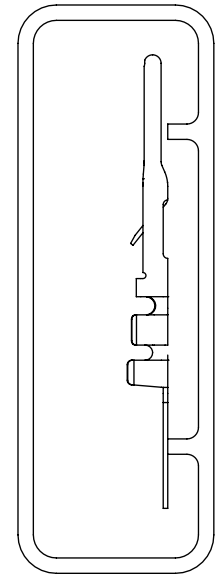

TUBE: PT-CC001  
PLUG: TP-03

SCALE 4:1

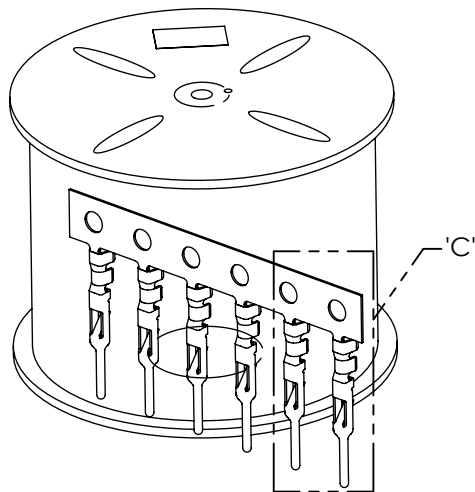

SCALE 2:1

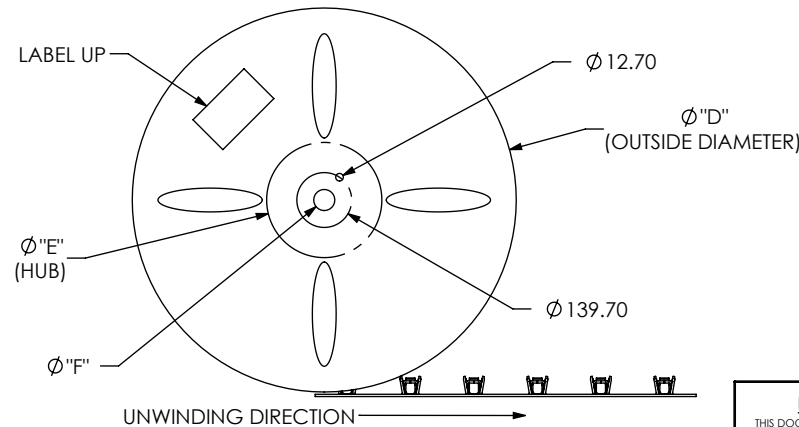
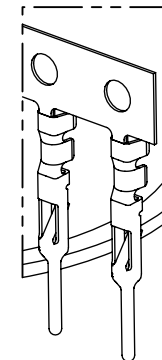

FIG 3  
REEL SPECIFICATIONS



DETAIL 'C'  
SCALE 3:1

PROPRIETARY NOTE  
THIS DOCUMENT CONTAINS INFORMATION  
CONFIDENTIAL AND PROPRIETARY TO  
SAMTEC, INC. AND SHALL NOT BE REPRODUCED  
OR TRANSFERRED TO OTHER DOCUMENTS OR  
DISCLOSED TO OTHERS OR USED FOR ANY  
PURPOSE OTHER THAN THAT WHICH IT WAS  
OBTAINED WITHOUT THE EXPRESSED WRITTEN  
CONSENT OF SAMTEC, INC.

DO NOT SCALE DRAWING

SHEET SCALE: 5:1



520 PARK EAST BLVD, NEW ALBANY, IN 47150  
PHONE: 812-944-6733 FAX: 812-948-5047  
e-Mail info@SAMTEC.com code 55322

DESCRIPTION:  
ACCLIMATE DISCRETE WIRE TERMINAL

DWG. NO.  
TC114-XXXX-X-X

BY: TRAVIS N 11/26/2013 SHEET 2 OF 2

TABLE 2				
SUPPLIED	REEL PART NUMBER	"D"	"E"	"F"
-R	R-24-08.00-1.00-P	609.60	203.2	28.58
-M	MR-13.0-4.00-24	330.20	101.6	12.70