



Chipsmall Limited consists of a professional team with an average of over 10 year of expertise in the distribution of electronic components. Based in Hongkong, we have already established firm and mutual-benefit business relationships with customers from,Europe,America and south Asia,supplying obsolete and hard-to-find components to meet their specific needs.

With the principle of “Quality Parts,Customers Priority,Honest Operation,and Considerate Service”,our business mainly focus on the distribution of electronic components. Line cards we deal with include Microchip,ALPS,ROHM,Xilinx,Pulse,ON,Everlight and Freescale. Main products comprise IC,Modules,Potentiometer,IC Socket,Relay,Connector.Our parts cover such applications as commercial,industrial, and automotives areas.

We are looking forward to setting up business relationship with you and hope to provide you with the best service and solution. Let us make a better world for our industry!



Contact us

Tel: +86-755-8981 8866 Fax: +86-755-8427 6832

Email & Skype: info@chipsmall.com Web: www.chipsmall.com

Address: A1208, Overseas Decoration Building, #122 Zhenhua RD., Futian, Shenzhen, China



T-Series

T-Series

SINGLE POLE ROCKER & PADDLE SWITCHES

The predecessor to the Corvette series whose versatility has allowed it to stand the test of time. Traditional styling coupled with self cleaning contacts, integrated wire leads, a multitude of circuits, ratings, and actuator choices has made the TA/LTA-Series appeal to a wide range of markets.

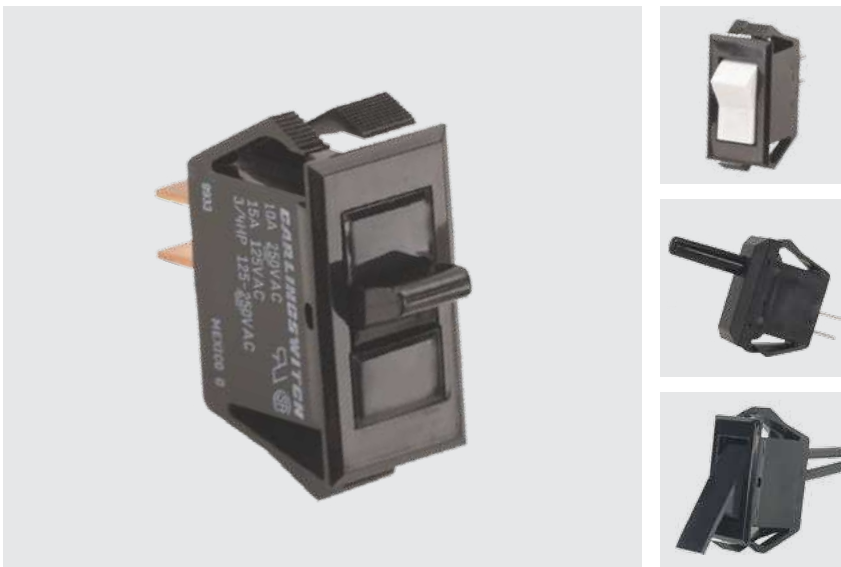

Product Highlights:

- ◆ Ratings Up To 20A
- ◆ Rocker, Paddle, Plunger or Door Interlock Actuators
- ◆ Integrated Wire Lead Construction
- ◆ Self-Cleaning Wiping Style Contacts

Typical Applications:

- ◆ Appliance
- ◆ HVAC
- ◆ Food Service
- ◆ Transportation



Dielectric Strength

UL/CSA:
1000V - live to dead metal parts

Electrical Life

100,000 cycles

Mechanical Life

100,000 cycles

Operating Temperature

32°F to 185°F (0°C to 85°C)

TA201 - T B - B

¹
Base Part Number

²
Actuator Style

³
Actuator Color

⁴
Bezel Color/Style

1 BASE PART NUMBER: SERIES / CIRCUITRY / RATING ⁴ / TERMINATION

10A 250 VAC, 15A 125 VAC, 3/4 HP 125-250 VAC
Solder Lugs .250 Tabs Wire Leads

Standard Base
ON-NONE-OFF TA200 TA201 TA205
ON-NONE-ON TB200 TB201 TB205
ON-OFF-ON TC200 TC201 TC205

5A 250 VAC, 10A 125 VAC, 1/2 HP 125-250 VAC
(ON)-NONE-OFF TA10A TA10B TA10F
(ON)-NONE-(OFF) TA10L TA10M TA10T
ON-NONE-(ON) TB10A TB10B TB10F

T-SERIES WITH PLUNGER ACTUATOR^{1,2}

10A 250 VAC, 16A 125 VAC, 1/2 HP 125-250 VAC
OFF-NONE-(ON) - TA25B-PLB-B TA25F-PLB-B
ON-NONE-(OFF) - - TA25T-PLB-B

T-SERIES WITH MOMENTARY ROCKER ACTUATOR

10A 250 VAC, 15A 125 VAC, 20A 125-250 VAC "H", 3/4 HP 125-250 VAC
(ON)-NONE-OFF - TA22B-TLB-B -
ON-NONE-(OFF) - TA22M-TLB-B -

2 ACTUATOR STYLE

T Rocker PS Short Paddle
P Paddle

3 ACTUATOR COLOR ⁵

B Black W White

4 BEZEL COLOR ⁵

B Black W White

Notes:

- Imprinting is available. Consult factory.
- 1 Optional plunger support option is available for applications requiring extensive lateral travel, consult factory for details.
- 2 Maintained circuit not available with TA22 and TA25 Series.
- 3 .187 tab terminals also available. Consult factory for catalog number callout.
- 4 Additional ratings are available. Consult factory.
- 5 Additional colors are available. Consult factory.
- () Indicates momentary function.

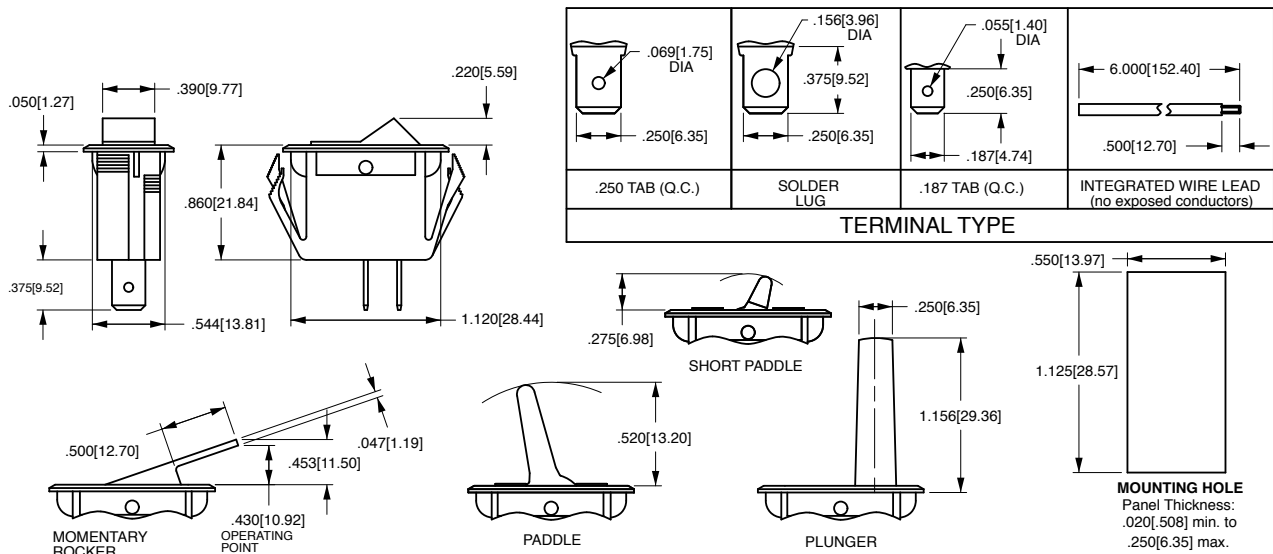

*Manufacturer reserves the right to change product specification without prior notice.

Authorized Sales Representatives and Distributors

Click on a region of the map below to find your local representatives and distributors or visit www.carlingtech.com/findarep.



About Carling

Founded in 1920, Carling Technologies is a leading manufacturer of electrical and electronic switches and assemblies, circuit breakers, electronic controls, power distribution units, and multiplexed power distribution systems. With four ISO registered manufacturing facilities and technical sales offices worldwide, Carling Technologies Sales, Service and Engineering teams do much more than manufacture electrical components, they engineer powerful solutions! To learn more about Carling please visit www.carlingtech.com/company-profile.

To view all of Carling's environmental, quality, health & safety certifications please visit www.carlingtech.com/environmental-certifications

Worldwide Headquarters

Carling Technologies, Inc.
60 Johnson Avenue, Plainville, CT 06062
Phone: 860.793.9281 **Fax:** 860.793.9231
Email: sales@carlingtech.com

Northern Region Sales Office: nrsm@carlingtech.com
Southeast Region Sales Office: sersm@carlingtech.com
Midwest Region Sales Office: mrrsm@carlingtech.com
West Region Sales Office: wrsm@carlingtech.com
Latin America Sales Office: larsm@carlingtech.com

Asia-Pacific Headquarters

Carling Technologies, Asia-Pacific Ltd.,
Suite 1607, 16/F Tower 2, The Gateway,
Harbour City, 25 Canton Road,
Tsimshatsui, Kowloon, Hong Kong
Phone: Int + 852-2737-2277 **Fax:** Int + 852-2736-9332
Email: sales@carlingtech.com.hk

Shenzhen, China: shenzhen@carlingtech.com
Shanghai, China: shanghai@carlingtech.com
Pune, India: india@carlingtech.com
Kaohsiung, Taiwan: taiwan@carlingtech.com
Yokohama, Japan: japan@carlingtech.com

Europe | Middle East | Africa Headquarters

Carling Technologies LTD
4 Airport Business Park, Exeter Airport,
Clyst Honiton, Exeter, Devon, EX5 2UL, UK
Phone: Int + 44 1392.364422 **Fax:** Int + 44 1392.364477
Email: ltd.sales@carlingtech.com

Germany: gmbh@carlingtech.com
France: sas@carlingtech.com



Carling Technologies®

Innovative Designs. Powerful Solutions.