



Chipsmall Limited consists of a professional team with an average of over 10 year of expertise in the distribution of electronic components. Based in Hongkong, we have already established firm and mutual-benefit business relationships with customers from,Europe,America and south Asia,supplying obsolete and hard-to-find components to meet their specific needs.

With the principle of “Quality Parts,Customers Priority,Honest Operation,and Considerate Service”,our business mainly focus on the distribution of electronic components. Line cards we deal with include Microchip,ALPS,ROHM,Xilinx,Pulse,ON,Everlight and Freescale. Main products comprise IC,Modules,Potentiometer,IC Socket,Relay,Connector.Our parts cover such applications as commercial,industrial, and automotives areas.

We are looking forward to setting up business relationship with you and hope to provide you with the best service and solution. Let us make a better world for our industry!



Contact us

Tel: +86-755-8981 8866 Fax: +86-755-8427 6832

Email & Skype: info@chipsmall.com Web: www.chipsmall.com

Address: A1208, Overseas Decoration Building, #122 Zhenhua RD., Futian, Shenzhen, China



PCB LAYOUT NOTES:

- 1. Allow clearance for finger squeeze access from the two sides shown.**
- 2. No tracks or vias in the shaded "KEEP OUT" area.**
- 3. No other track or signal within 0.020" of any contact pad.**
- 4. Do not allow solder paste on the contact pads. It is essential to eliminate any hole in the solder paste-mask (solder stencil) layer. If this is not possible make the contact pads thru-hole with finished hole size of 0.012" or less.**
- 5. To avoid ordering confusion, please specify DNL in your BOM.**
- 6. Leg and alignment holes may be plated and used as vias but ensure minimum finished hole size meets specified tolerances.**

TC2070-IDC PLUG-OF-NAILS(TM) CABLE			
REV	DESCRIPTION	DATE	REV BY
C	CORRECTED .225" [5.715mm] LEG SPACING TO .325"[8.255mm].	12/16/2017	B.EASTMAN

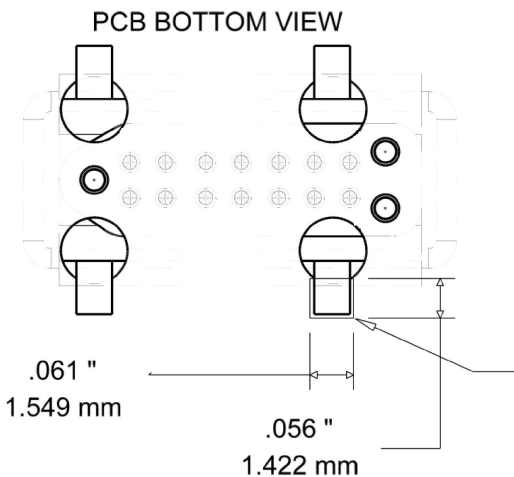
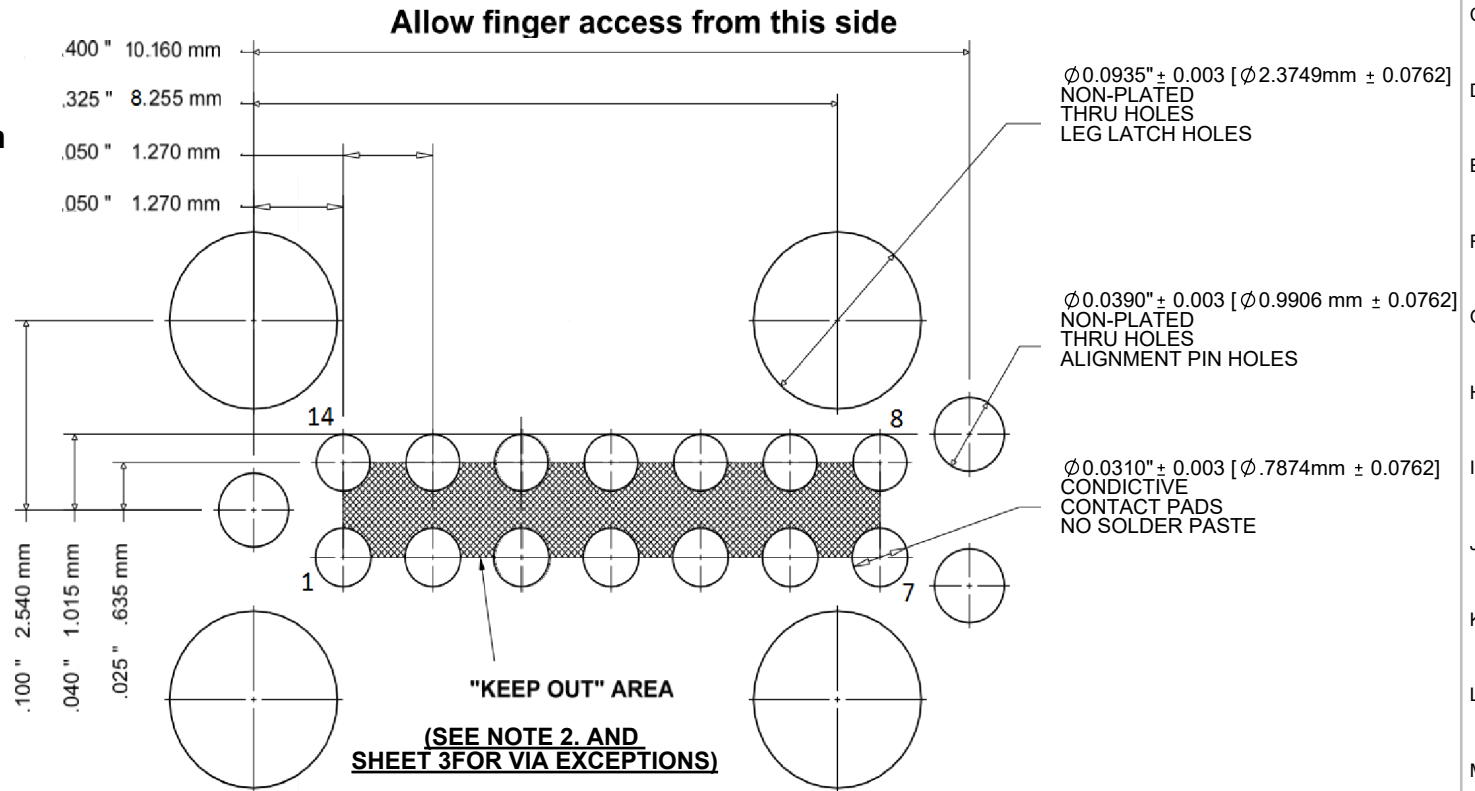

ALLOW A 0.061 x 0.056 SQUARE AREA OF CLEARANCE FOR EACH FOOT

FOOTPRINT TO BE LABELED "TC2070-FP" ON LAYOUT / BOM

Use TC2070-FP (or TC2070-NL-FP) as the PCB "part" name – the cable must not appear on your BOM! Ensure the "part" in the PCB BOM is labelled as "Nothing to Purchase - Do Not Install" otherwise your CM's will try to buy one cable per PCB assembly!

SIZE A	FSCM NO.	DWG NO. TC2070-IDC	REV C
SCALE 1:5	www.TAG-CONNECT.com		SHEET 1 OF 3

Note:
Dimmensions subject to change.

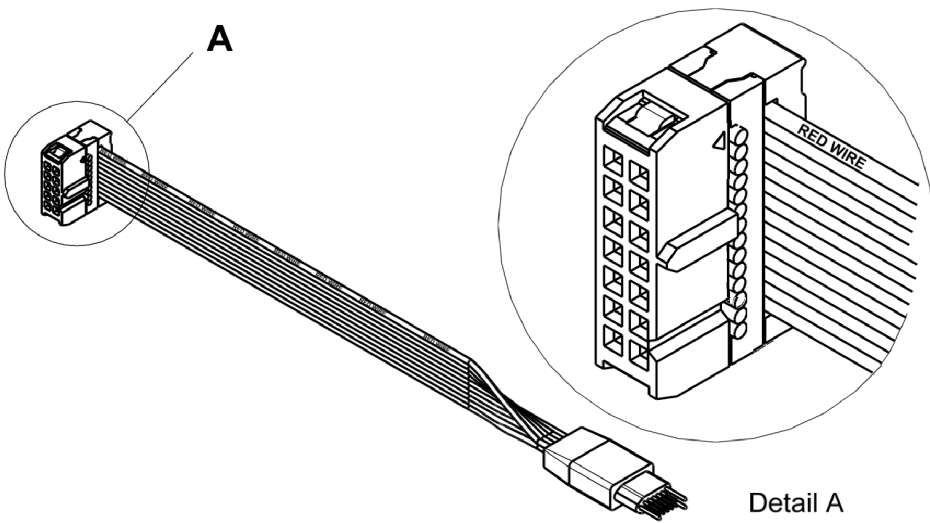
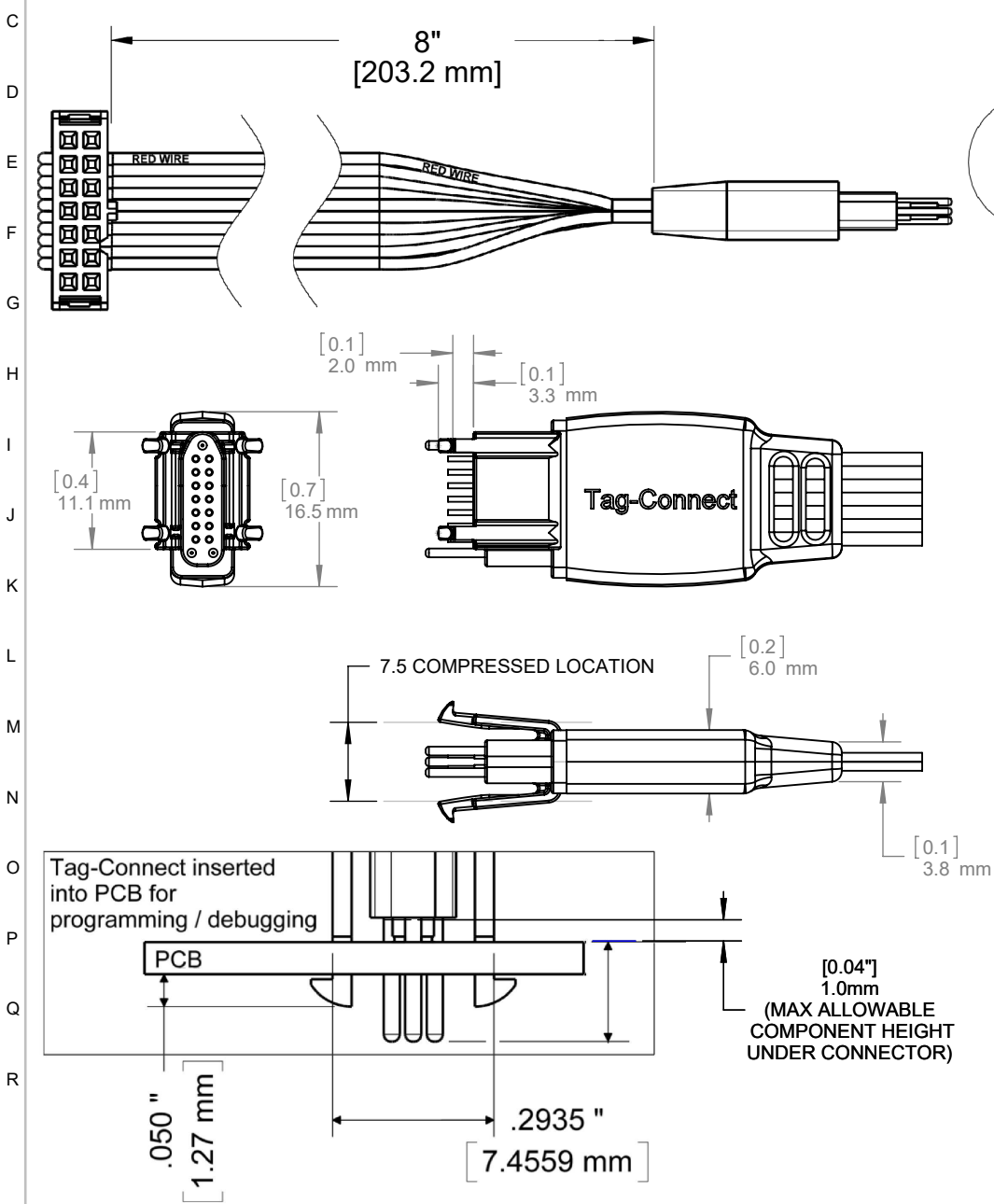

**END VIEW
2x7 0.1" PITCH
IDC CONNECTOR**

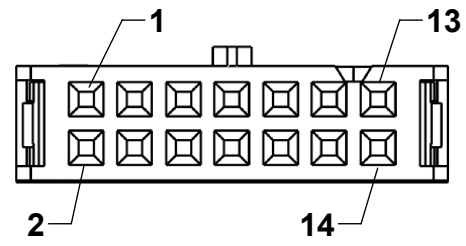

**END VIEW
14 PIN
TAG-CONNECT**

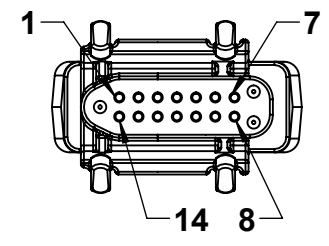

SIZE A	FSCM NO.	DWG NO. TC2070-IDC	REV C
SCALE 2:1	www.TAG-CONNECT.com		SHEET 2 OF 3

Layout Problems to Avoid

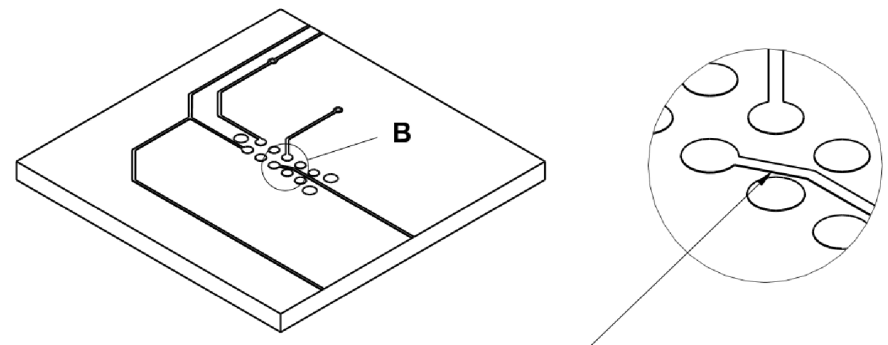
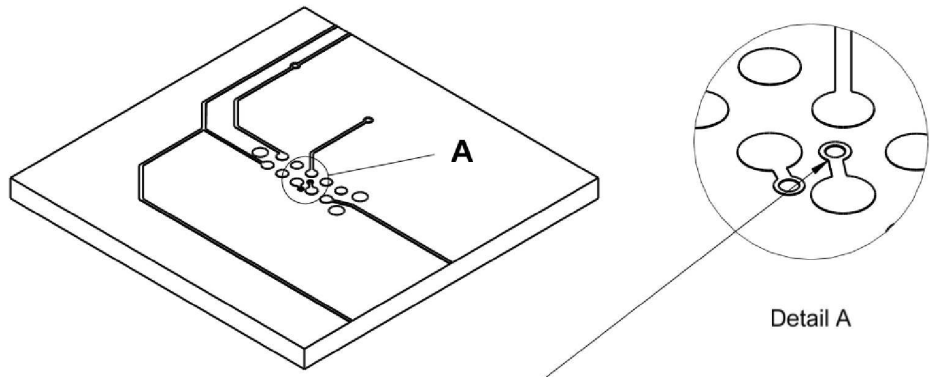

Vias between contact pads

OKAY

Traces less than .02" away from contact pad or in "KEEP OUT" area

NOT OKAY

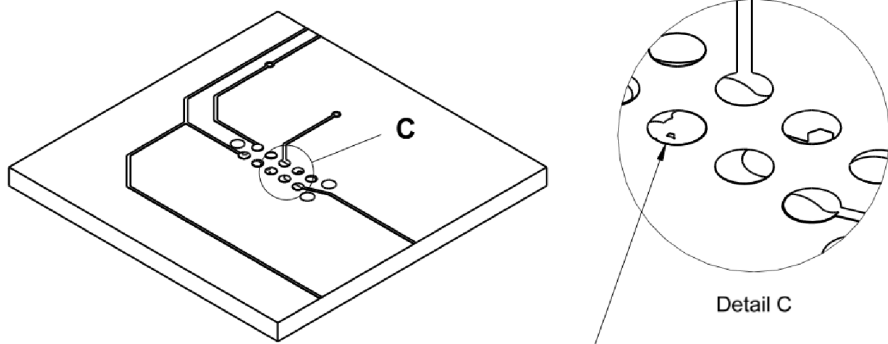

Do not deposit solder paste on contact pads. View Solder Paste Mask (Solder Stencil) layer in pad-stack and eliminate any hole.

Notes:

- 1) It IS OK to have a conductive via (not filled, not soldermasked) in the center of any of the pads so long as the finished hole is 0.012" or smaller.
- 2) It's NOT OK to have a via between two pads without 0.02" between the via and a pad of a different signal.
- 3) It IS OK to have a small via centered between four pads.

SIZE A	FSCM NO.	DWG NO. TC2070-IDC	REV C
SCALE 2:1	www.TAG-CONNECT.com		SHEET 3 OF 3