



Chipsmall Limited consists of a professional team with an average of over 10 year of expertise in the distribution of electronic components. Based in Hongkong, we have already established firm and mutual-benefit business relationships with customers from,Europe,America and south Asia,supplying obsolete and hard-to-find components to meet their specific needs.

With the principle of “Quality Parts,Customers Priority,Honest Operation,and Considerate Service”,our business mainly focus on the distribution of electronic components. Line cards we deal with include Microchip,ALPS,ROHM,Xilinx,Pulse,ON,Everlight and Freescale. Main products comprise IC,Modules,Potentiometer,IC Socket,Relay,Connector.Our parts cover such applications as commercial,industrial, and automotives areas.

We are looking forward to setting up business relationship with you and hope to provide you with the best service and solution. Let us make a better world for our industry!



Contact us

Tel: +86-755-8981 8866 Fax: +86-755-8427 6832

Email & Skype: info@chipsmall.com Web: www.chipsmall.com

Address: A1208, Overseas Decoration Building, #122 Zhenhua RD., Futian, Shenzhen, China



TOSHIBA MOS DIGITAL INTEGRATED CIRCUIT SILICON GATE CMOS

4 GBIT (512M × 8 BIT) CMOS NAND E²PROM**DESCRIPTION**

The TC58NVG2S0HTA00 is a single 3.3V 4 Gbit (4,563,402,752 bits) NAND Electrically Erasable and Programmable Read-Only Memory (NAND E²PROM) organized as (4096 + 256) bytes × 64 pages × 2048 blocks. The device has two 4352-byte static registers which allow program and read data to be transferred between the register and the memory cell array in 4352-byte increments. The Erase operation is implemented in a single block unit (256 Kbytes + 16 Kbytes: 4352 bytes × 64 pages).

The TC58NVG2S0HTA00 is a serial-type memory device which utilizes the I/O pins for both address and data input/output as well as for command inputs. The Erase and Program operations are automatically executed making the device most suitable for applications such as solid-state file storage, voice recording, image file memory for still cameras and other systems which require high-density non-volatile memory data storage.

FEATURES

- Organization

	x8
Memory cell array	4352 × 128K × 8
Register	4352 × 8
Page size	4352 bytes
Block size	(256K + 16K) bytes
- Modes
 - Read, Reset, Auto Page Program, Auto Block Erase, Status Read, Page Copy, Multi Page Program, Multi Block Erase, Multi Page Copy, Multi Page Read
- Mode control
 - Serial input/output
 - Command control
- Number of valid blocks
 - Min 2008 blocks
 - Max 2048 blocks
- Power supply
 - V_{CC} = 2.7V to 3.6V
- Access time

Cell array to register	25 μs max
Serial Read Cycle	25 ns min (CL=50pF)
- Program/Erase time

Auto Page Program	300 μs/page typ.
Auto Block Erase	2.5 ms/block typ.
- Operating current

Read (25 ns cycle)	30 mA max.
Program (avg.)	30 mA max
Erase (avg.)	30 mA max
Standby	50 μA max
- Package
 - TSOP I 48-P-1220-0.50 (Weight: 0.53 g typ.)
- 8 bit ECC for each 512Byte is required.

PIN ASSIGNMENT (TOP VIEW)

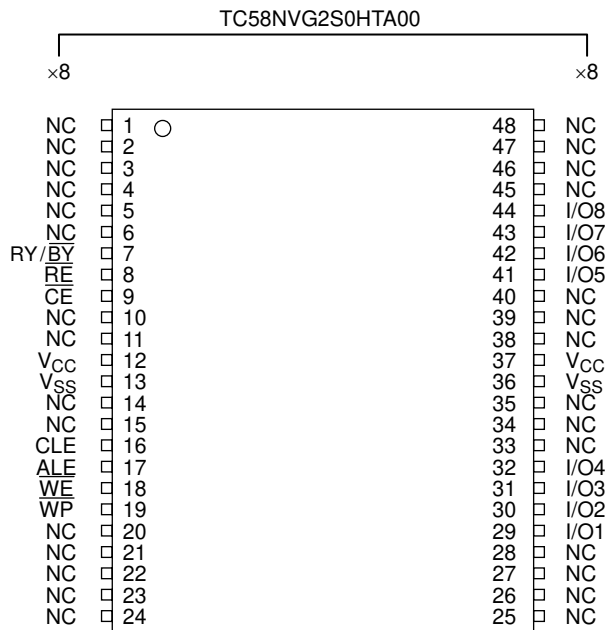

PIN NAMES

I/O1 to I/O8	I/O port
$\overline{\text{CE}}$	Chip enable
$\overline{\text{WE}}$	Write enable
$\overline{\text{RE}}$	Read enable
CLE	Command latch enable
ALE	Address latch enable
$\overline{\text{WP}}$	Write protect
RY/ $\overline{\text{BY}}$	Ready/Busy
V _{CC}	Power supply
V _{SS}	Ground
NC	No Connection

BLOCK DIAGRAM

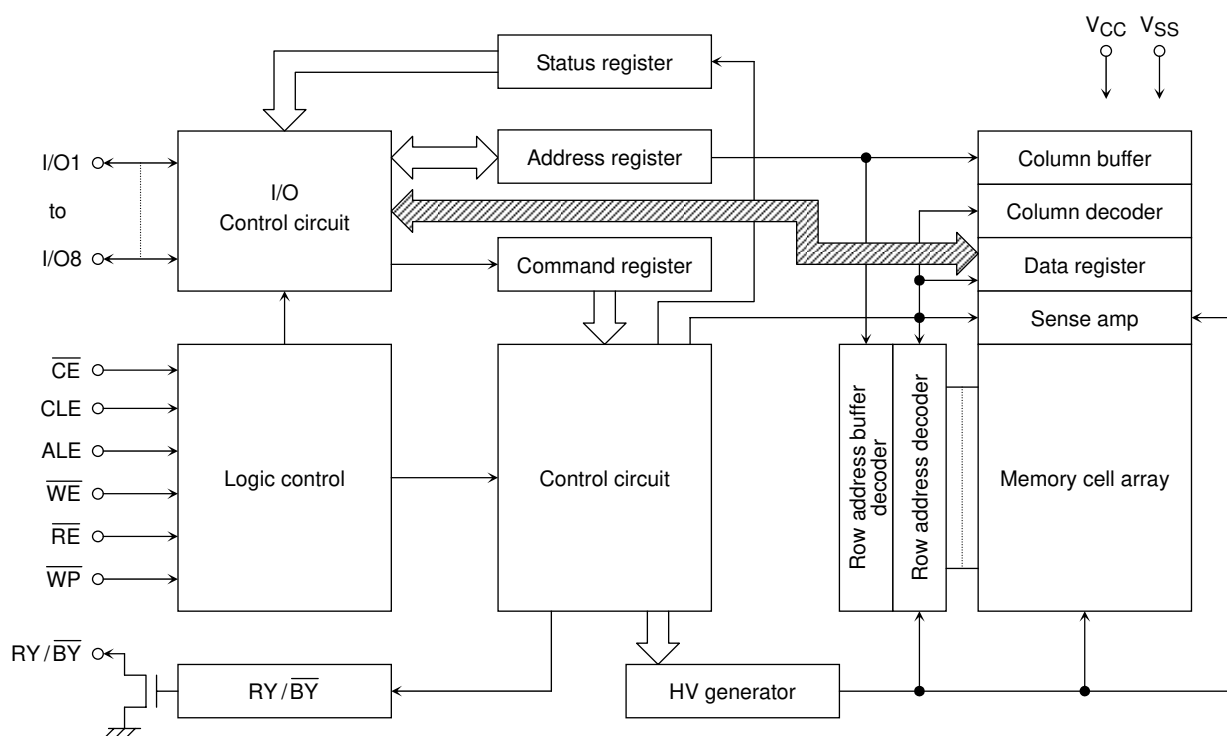

ABSOLUTE MAXIMUM RATINGS

SYMBOL	RATING	VALUE	UNIT
V _{CC}	Power Supply Voltage	-0.6 to 4.6	V
V _{IN}	Input Voltage	-0.6 to 4.6	V
V _{I/O}	Input /Output Voltage	-0.6 to V _{CC} + 0.3 (≤ 4.6 V)	V
P _D	Power Dissipation	0.3	W
T _{SOLDER}	Soldering Temperature (10 s)	260	°C
T _{STG}	Storage Temperature	-55 to 150	°C
T _{OPR}	Operating Temperature	0 to 70	°C

CAPACITANCE *(Ta = 25°C, f = 1 MHz)

SYMBOL	PARAMETER	CONDITION	MIN	MAX	UNIT
C _{IN}	Input	V _{IN} = 0 V	—	10	pF
C _{OUT}	Output	V _{OUT} = 0 V	—	10	pF

* This parameter is periodically sampled and is not tested for every device.

VALID BLOCKS

SYMBOL	PARAMETER	MIN	TYP.	MAX	UNIT
N _{VB}	Number of Valid Blocks	2008	—	2048	Blocks

NOTE: The device occasionally contains unusable blocks. Refer to Application Note (13) toward the end of this document.

The first block (Block 0) is guaranteed to be a valid block at the time of shipment.

The specification for the minimum number of valid blocks is applicable over lifetime

The number of valid blocks is on the basis of single plane operations, and this may be decreased with two plane operations.

RECOMMENDED DC OPERATING CONDITIONS

SYMBOL	PARAMETER	MIN	TYP.	MAX	UNIT
V _{CC}	Power Supply Voltage	2.7	—	3.6	V
V _{IH}	High Level input Voltage	V _{CC} × 0.8	—	V _{CC} + 0.3	V
V _{IL}	Low Level Input Voltage	-0.3*	—	V _{CC} × 0.2	V

* -2 V (pulse width lower than 20 ns)

DC CHARACTERISTICS (T_a = 0 to 70°C, V_{CC} = 2.7 to 3.6V)

SYMBOL	PARAMETER	CONDITION	MIN	TYP.	MAX	UNIT
I _{IL}	Input Leakage Current	V _{IN} = 0 V to V _{CC}	—	—	±10	μA
I _{LO}	Output Leakage Current	V _{OUT} = 0 V to V _{CC}	—	—	±10	μA
I _{CCO1}	Serial Read Current	$\overline{CE} = V_{IL}$, I _{OUT} = 0 mA, t _{cycle} = 25 ns	—	—	30	mA
I _{CCO2}	Programming Current	—	—	—	30	mA
I _{CCO3}	Erasing Current	—	—	—	30	mA
I _{CCS}	Standby Current	$\overline{CE} = V_{CC} - 0.2$ V, $\overline{WP} = 0$ V/V _{CC}	—	—	50	μA
V _{OH}	High Level Output Voltage	I _{OH} = -0.1 mA	V _{CC} - 0.2	—	—	V
V _{OL}	Low Level Output Voltage	I _{OL} = 0.1 mA	—	—	0.2	V
I _{OL} (R _Y /B _Y)	Output current of R _Y /B _Y pin	V _{OL} = 0.2 V	—	4	—	mA

AC CHARACTERISTICS AND RECOMMENDED OPERATING CONDITIONS (Ta = 0 to 70°C, Vcc = 2.7 to 3.6V)

SYMBOL	PARAMETER	MIN	MAX	UNIT
tCLS	CLE Setup Time	12	—	ns
tCLH	CLE Hold Time	5	—	ns
tCS	\overline{CE} Setup Time	20	—	ns
tCH	\overline{CE} Hold Time	5	—	ns
tWP	Write Pulse Width	12	—	ns
tALS	ALE Setup Time	12	—	ns
tALH	ALE Hold Time	5	—	ns
tDS	Data Setup Time	12	—	ns
tDH	Data Hold Time	5	—	ns
tWC	Write Cycle Time	25	—	ns
tWH	\overline{WE} High Hold Time	10	—	ns
tWW	\overline{WP} High to \overline{WE} Low	100	—	ns
tRR	Ready to \overline{RE} Falling Edge	20	—	ns
tRW	Ready to \overline{WE} Falling Edge	20	—	ns
tRP	Read Pulse Width	12	—	ns
tRC	Read Cycle Time	25	—	ns
tREA	\overline{RE} Access Time	—	20	ns
tCEA	\overline{CE} Access Time	—	25	ns
tCLR	CLE Low to \overline{RE} Low	10	—	ns
tAR	ALE Low to \overline{RE} Low	10	—	ns
tRHOH	\overline{RE} High to Output Hold Time	25	—	ns
tRLOH	\overline{RE} Low to Output Hold Time	5	—	ns
tRHZ	\overline{RE} High to Output High Impedance	—	60	ns
tCHZ	\overline{CE} High to Output High Impedance	—	20	ns
tCSD	\overline{CE} High to ALE or CLE Don't Care	0	—	ns
tREH	\overline{RE} High Hold Time	10	—	ns
tIR	Output-High-impedance-to- \overline{RE} Falling Edge	0	—	ns
tRHW	\overline{RE} High to \overline{WE} Low	30	—	ns
tWHC	\overline{WE} High to \overline{CE} Low	30	—	ns
tWHR	\overline{WE} High to \overline{RE} Low	60	—	ns
tR	Memory Cell Array to Starting Address	—	25	μs
tDCBSYR1	Data Cache Busy in Read Cache (following 31h and 3Fh)	—	25	μs
tDCBSYR2	Data Cache Busy in Page Copy (following 3Ah)	—	30	μs
tWB	\overline{WE} High to Busy	—	100	ns
tRST	Device Reset Time (Ready/Read/Program/Erase)	—	5/5/10/500	μs

*1: tCLS and tALS can not be shorter than tWP

*2: tCS should be longer than tWP + 8ns.

AC TEST CONDITIONS

PARAMETER	CONDITION
	V_{CC} : 2.7 to 3.6V
Input level	$V_{CC} - 0.2\text{ V}$, 0.2 V
Input pulse rise and fall time	3 ns
Input comparison level	$V_{CC} / 2$
Output data comparison level	$V_{CC} / 2$
Output load	C_L (50 pF) + 1 TTL

Note: Busy to ready time depends on the pull-up resistor tied to the $\overline{RY}/\overline{BY}$ pin.
(Refer to Application Note (9) toward the end of this document.)

PROGRAMMING AND ERASING CHARACTERISTICS
($T_a = 0$ to 70°C , $V_{CC} = 2.7$ to 3.6V)

SYMBOL	PARAMETER	MIN	TYP.	MAX	UNIT	NOTES
t_{PROG}	Average Programming Time	—	300	700	μs	
t_{DCBSYW1}	Data Cache Busy Time in Write Cache (following 11h)	—	—	10	μs	
t_{DCBSYW2}	Data Cache Busy Time in Write Cache (following 15h)	—	—	700	μs	(2)
N	Number of Partial Program Cycles in the Same Page	—	—	4		(1)
t_{BERASE}	Block Erasing Time	—	2.5	5	ms	

(1) Refer to Application Note (12) toward the end of this document.

(2) t_{DCBSYW2} depends on the timing between internal programming time and data in time.

Data Output

When t_{REH} is long, output buffers are disabled by $\overline{RE}=\text{High}$, and the hold time of data output depend on t_{RHOH} (25ns MIN). On this condition, waveforms look like normal serial read mode.

When t_{REH} is short, output buffers are not disabled by $\overline{RE}=\text{High}$, and the hold time of data output depend on t_{RLOH} (5ns MIN). On this condition, output buffers are disabled by the rising edge of $\overline{CLE}, \overline{ALE}, \overline{CE}$ or falling edge of \overline{WE} , and waveforms look like Extended Data Output Mode.

TIMING DIAGRAMS

Latch Timing Diagram for Command/Address/Data

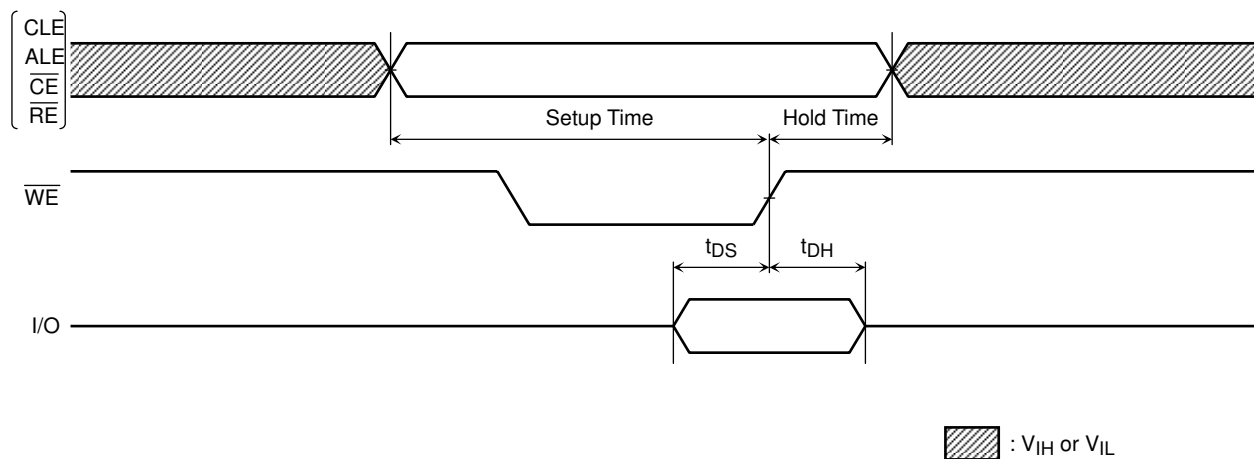

Command Input Cycle Timing Diagram

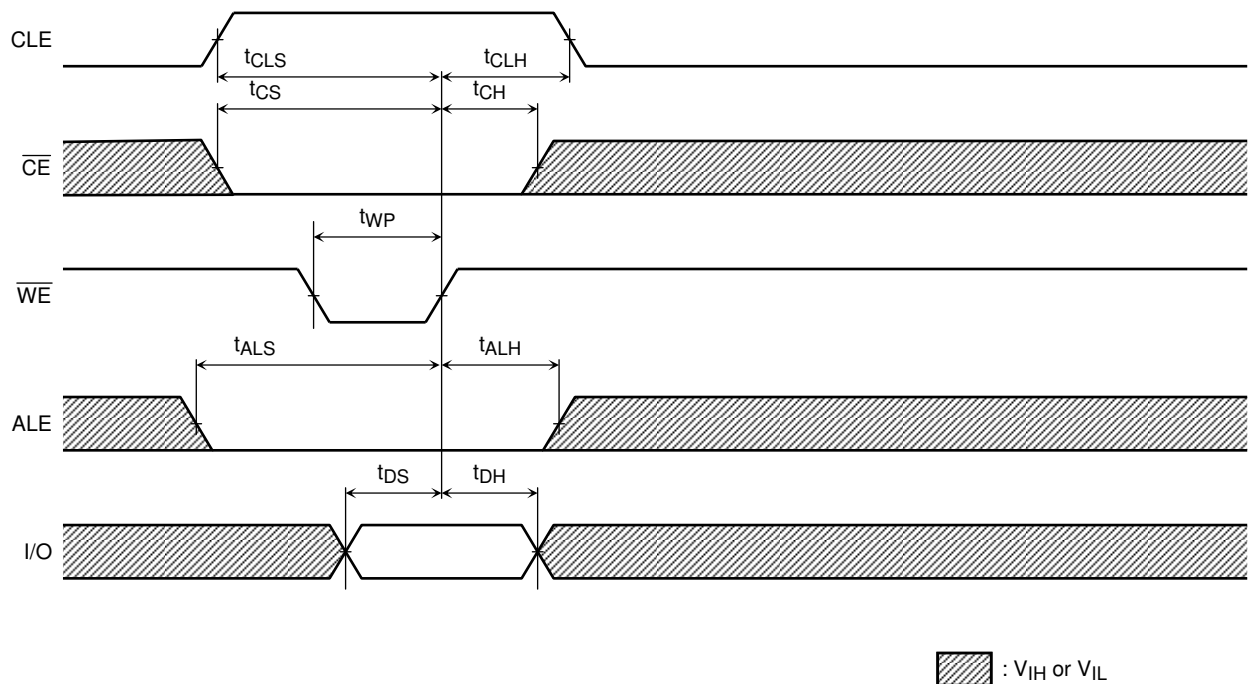

Address Input Cycle Timing Diagram

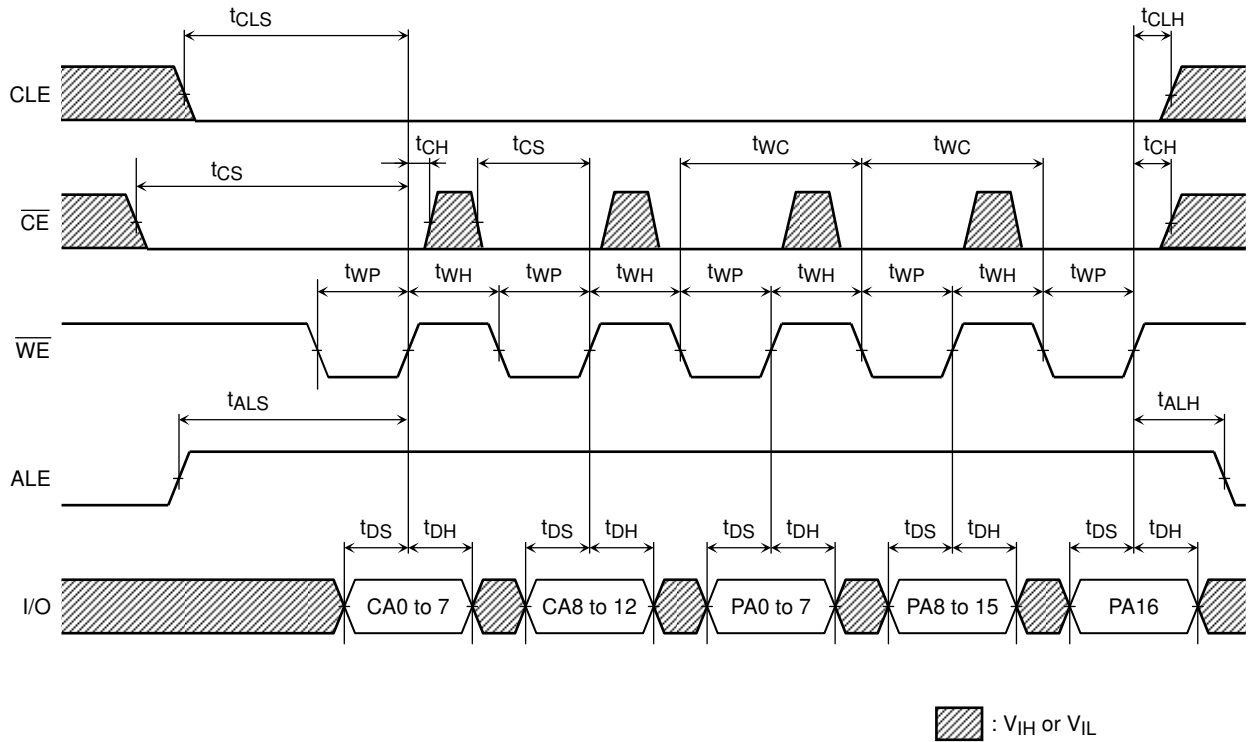

Data Input Cycle Timing Diagram

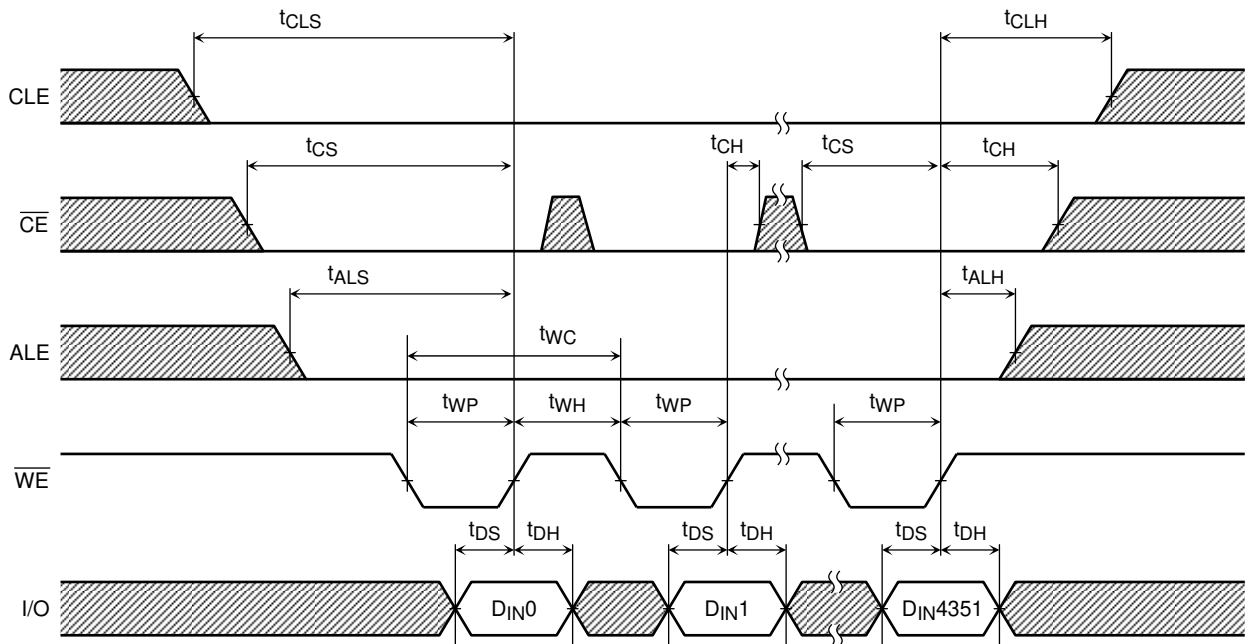

Serial Read Cycle Timing Diagram

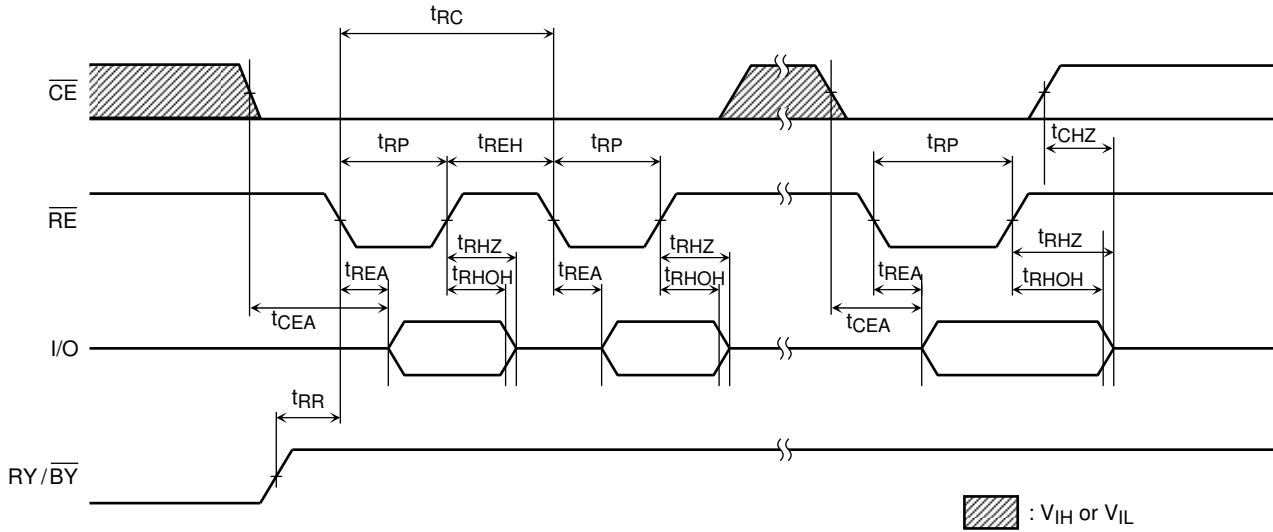

Status Read Cycle Timing Diagram

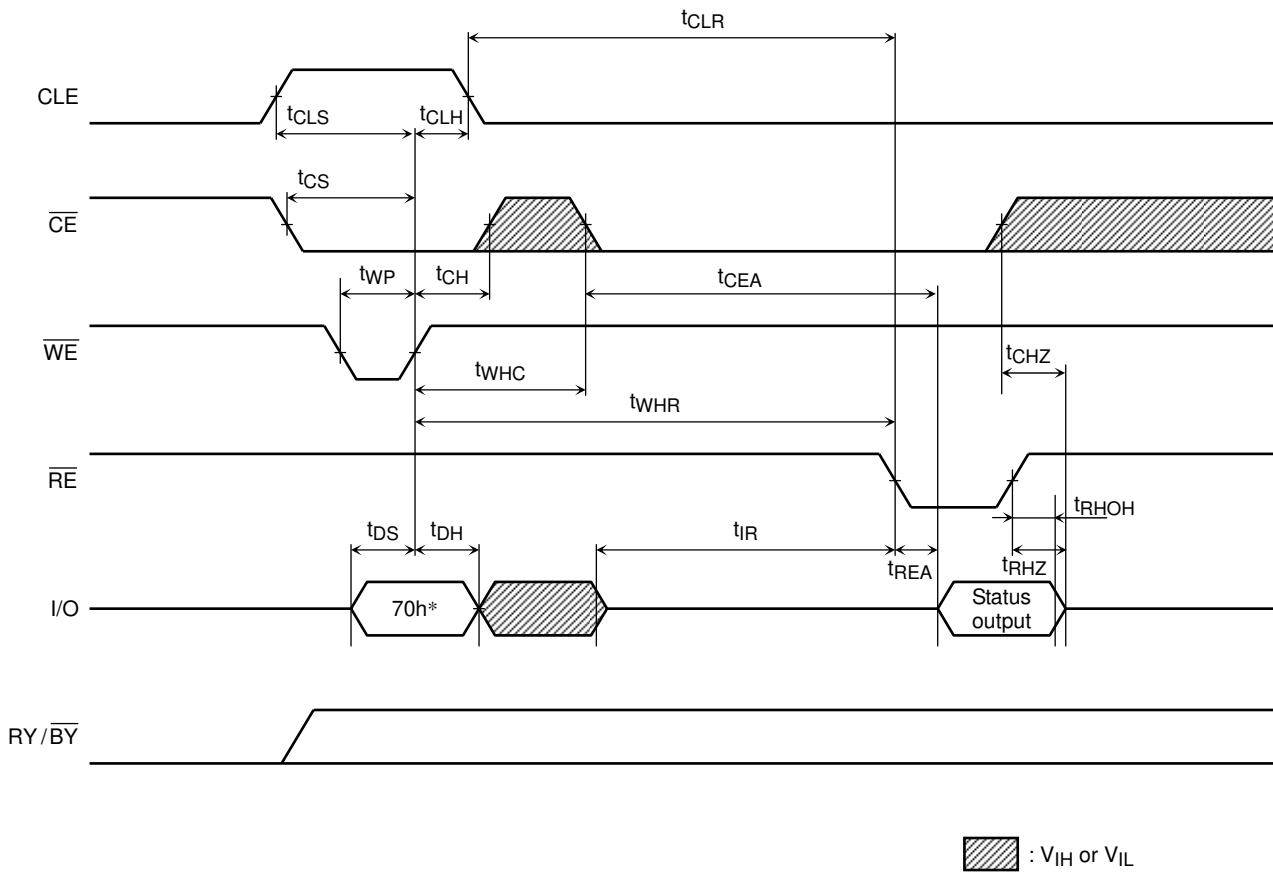

Read Cycle Timing Diagram

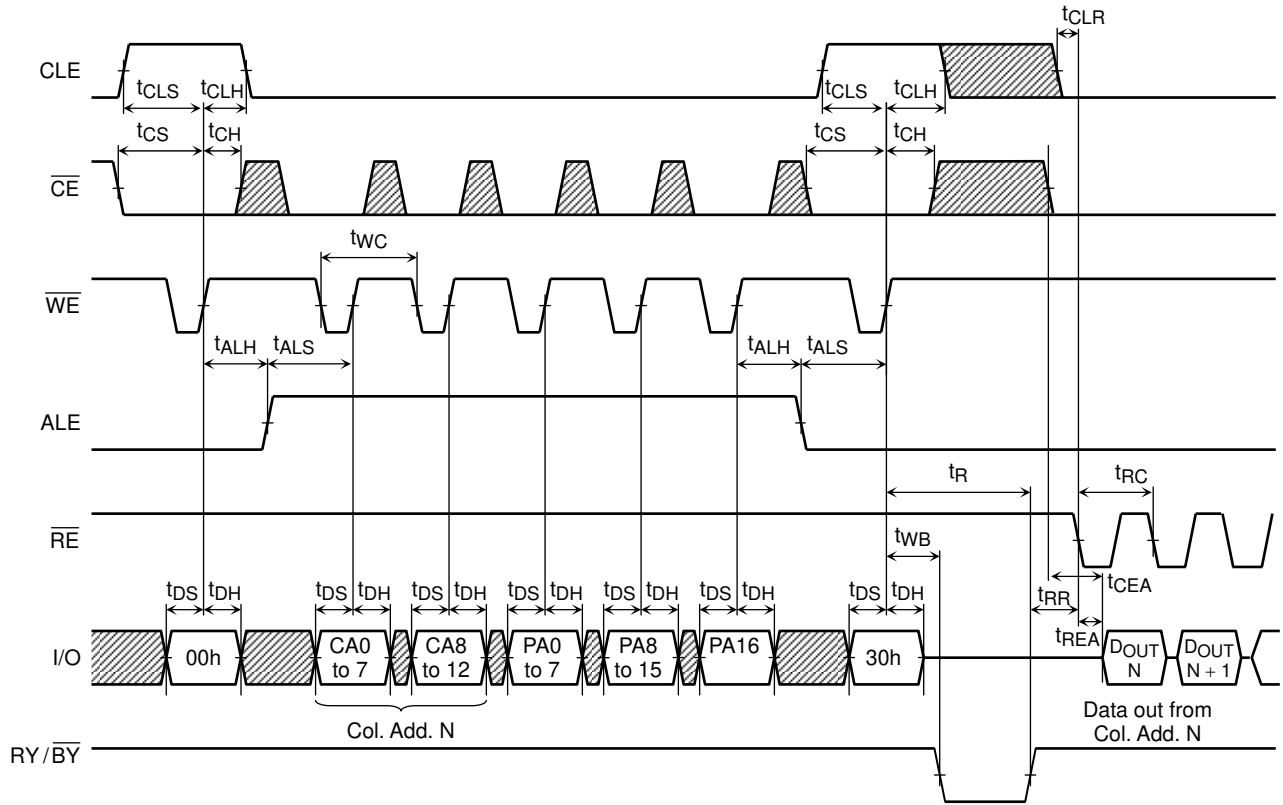

Read Cycle Timing Diagram: When Interrupted by \overline{CE}

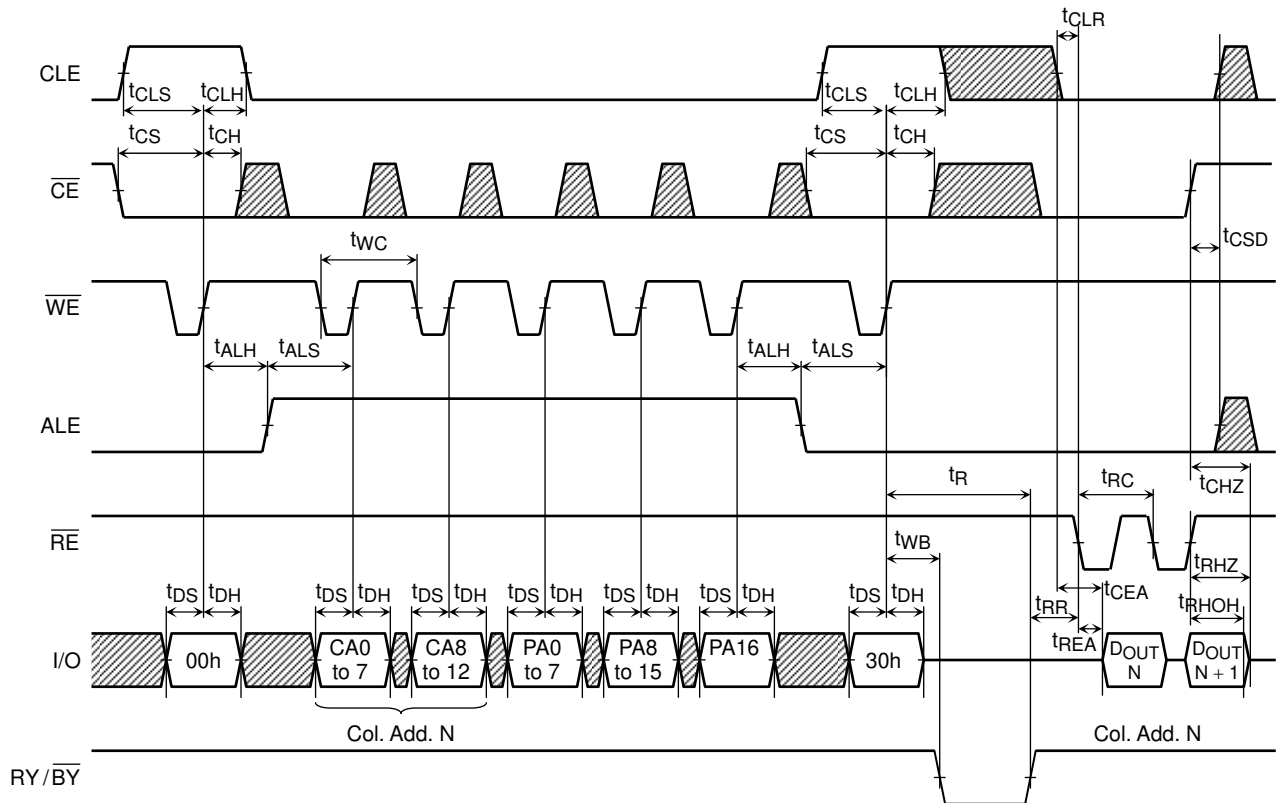

Read Cycle with Data Cache Timing Diagram (1/2)

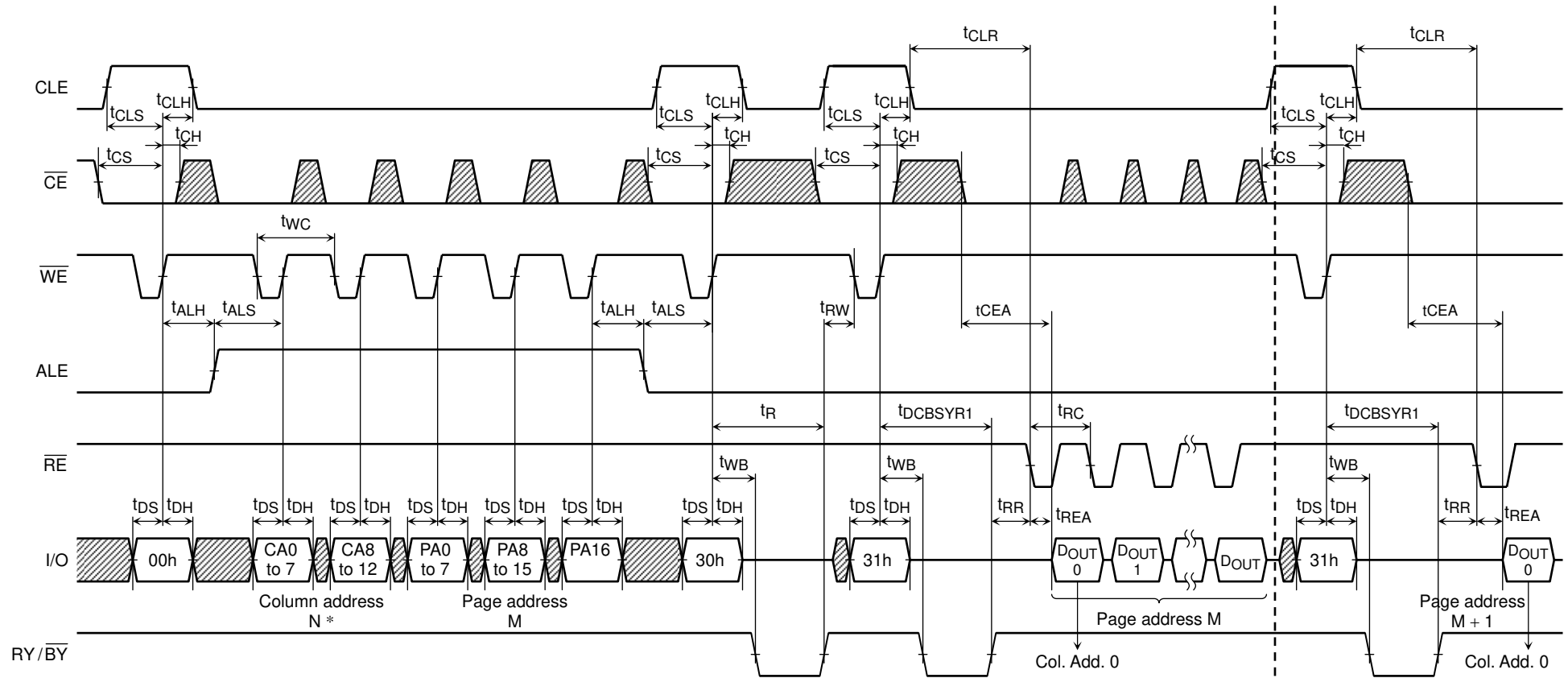

* The column address will be reset to 0 by the 31h command input.

1

Continues to 1 of next page

Read Cycle with Data Cache Timing Diagram (2/2)

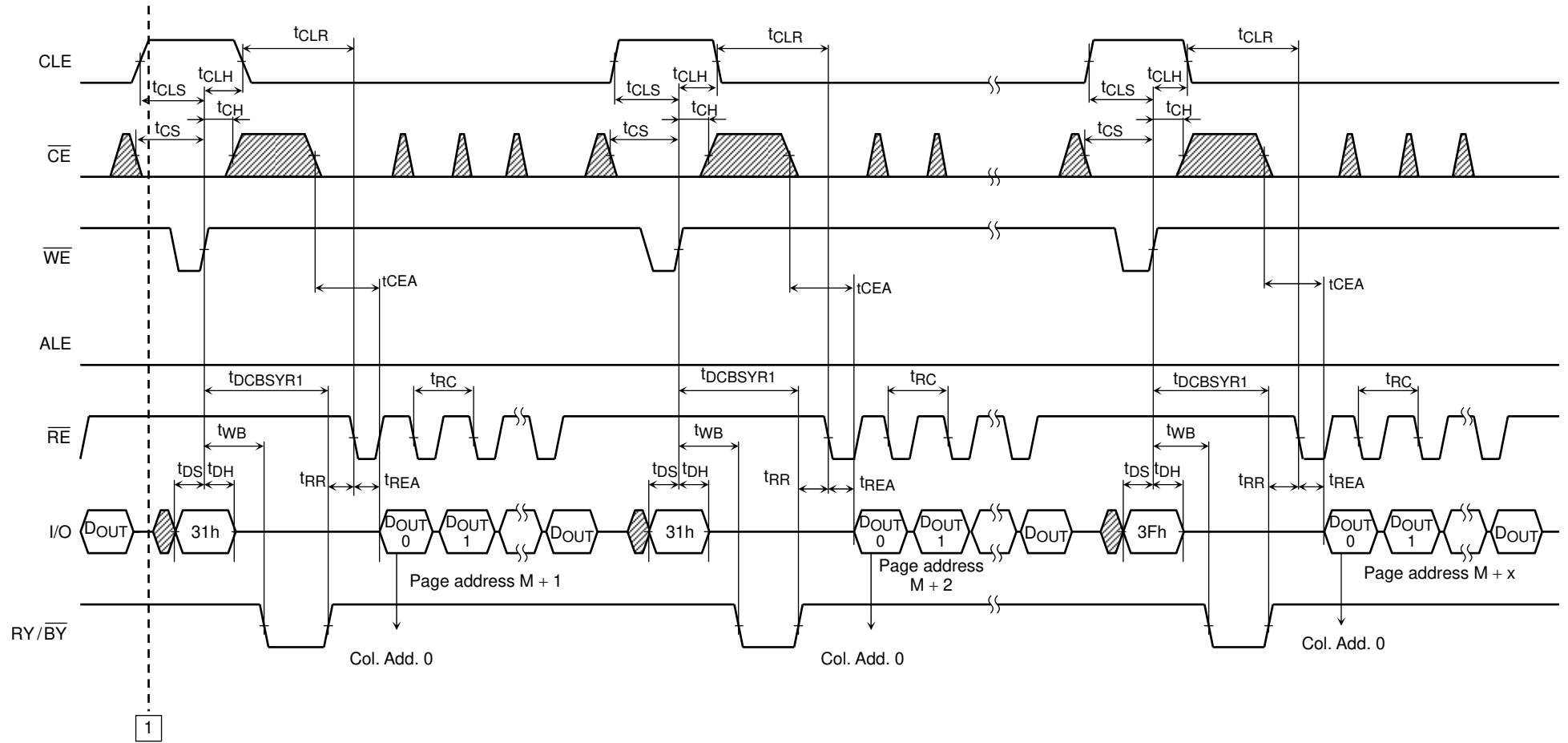

Continues from 1 of previous page

Make sure to terminate the operation with 3Fh command.

Column Address Change in Read Cycle Timing Diagram (1/2)

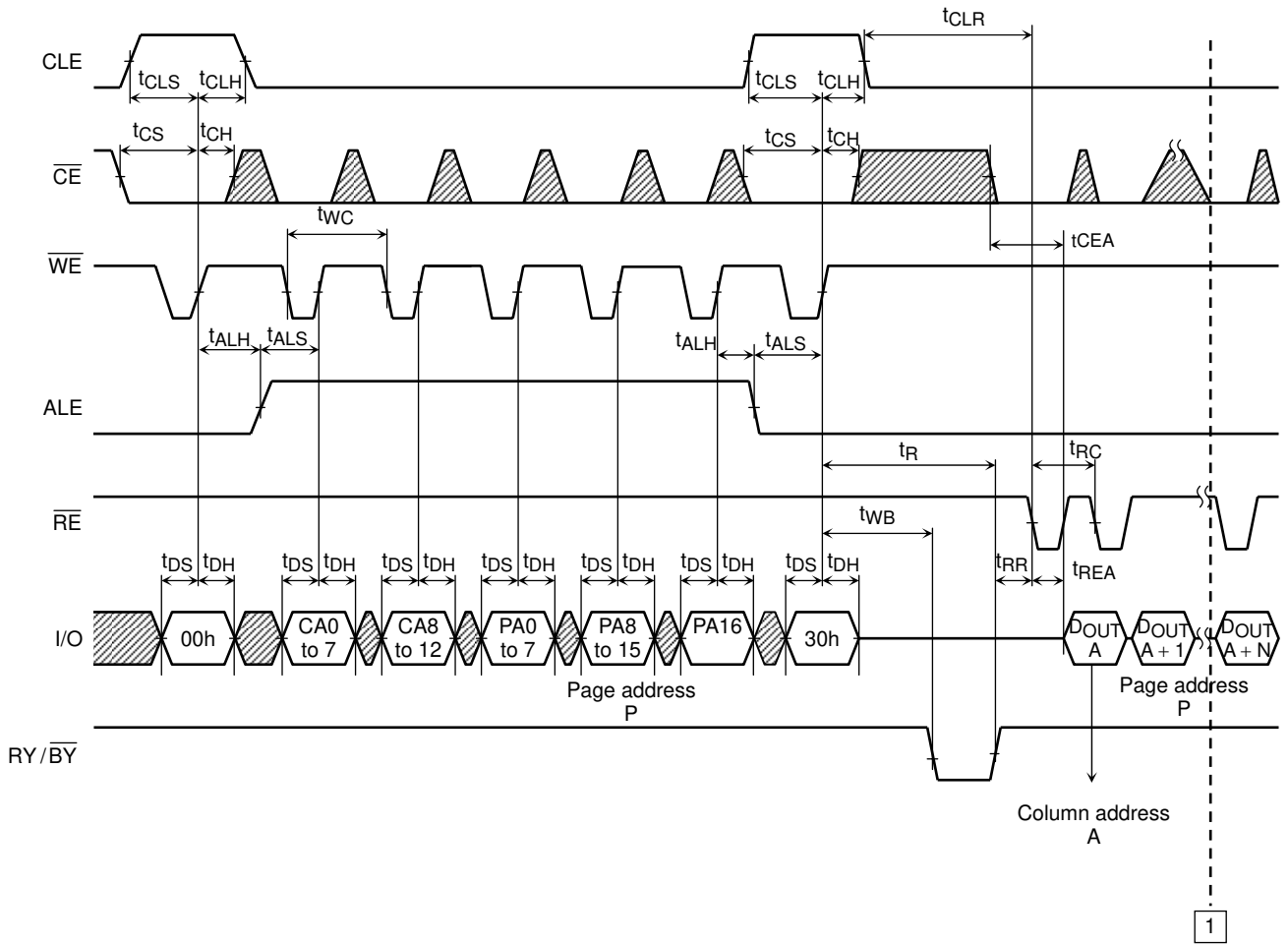

Continues to 1 of next page

Column Address Change in Read Cycle Timing Diagram (2/2)

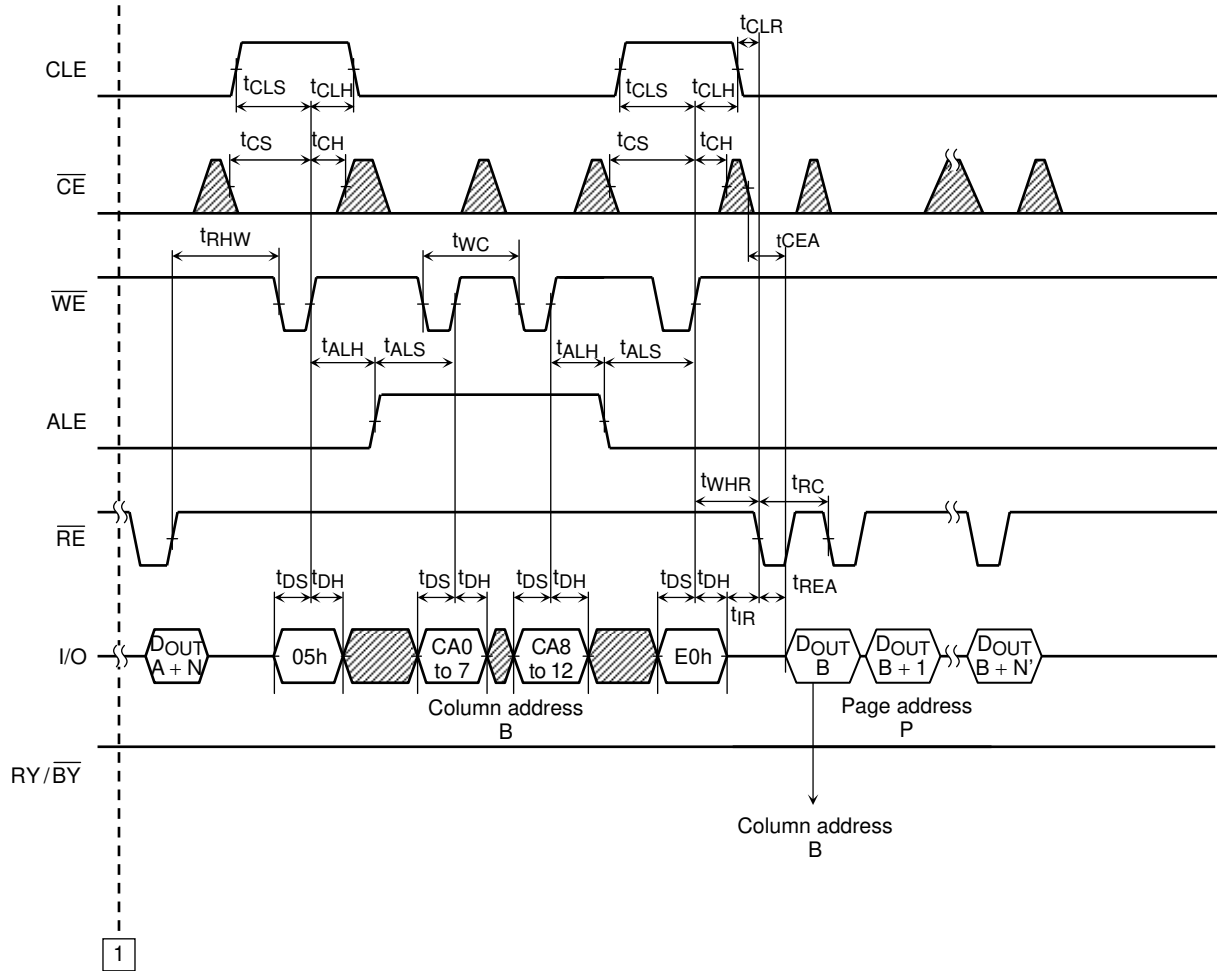

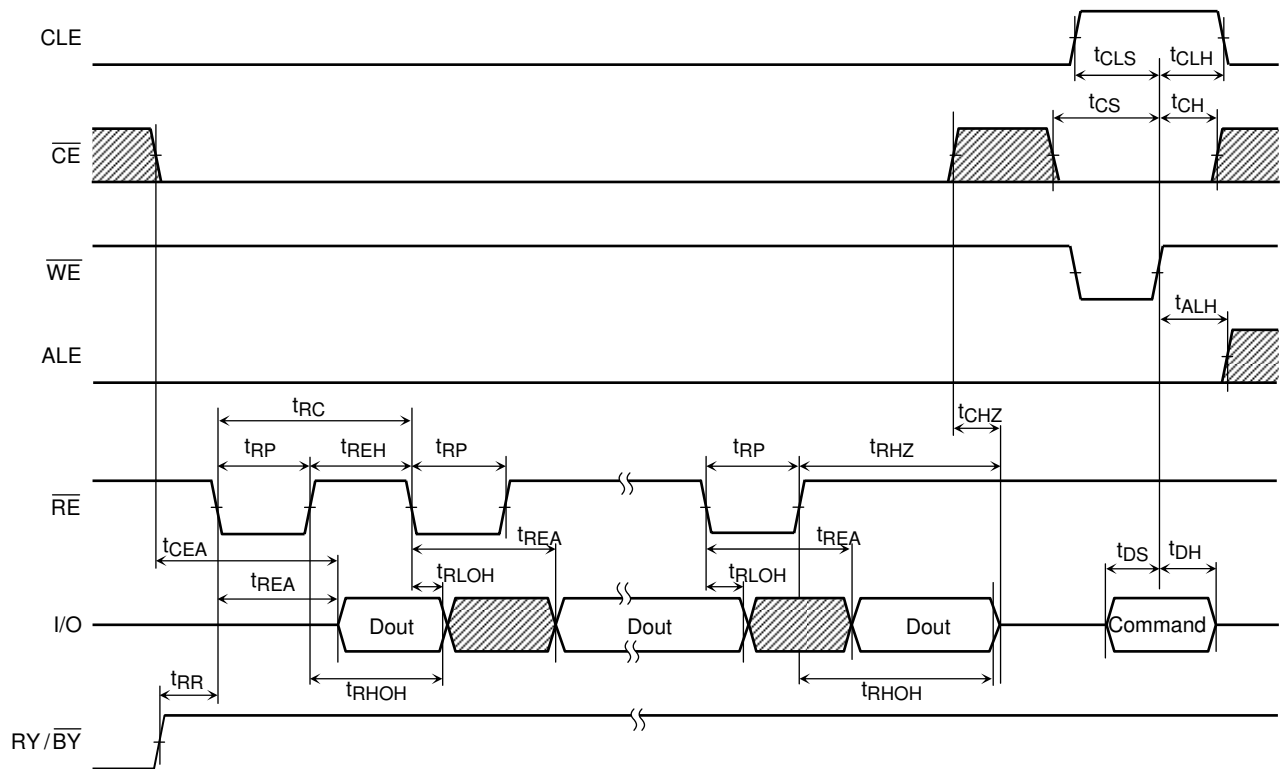

Continues from 1 of previous page

Data Output Timing Diagram

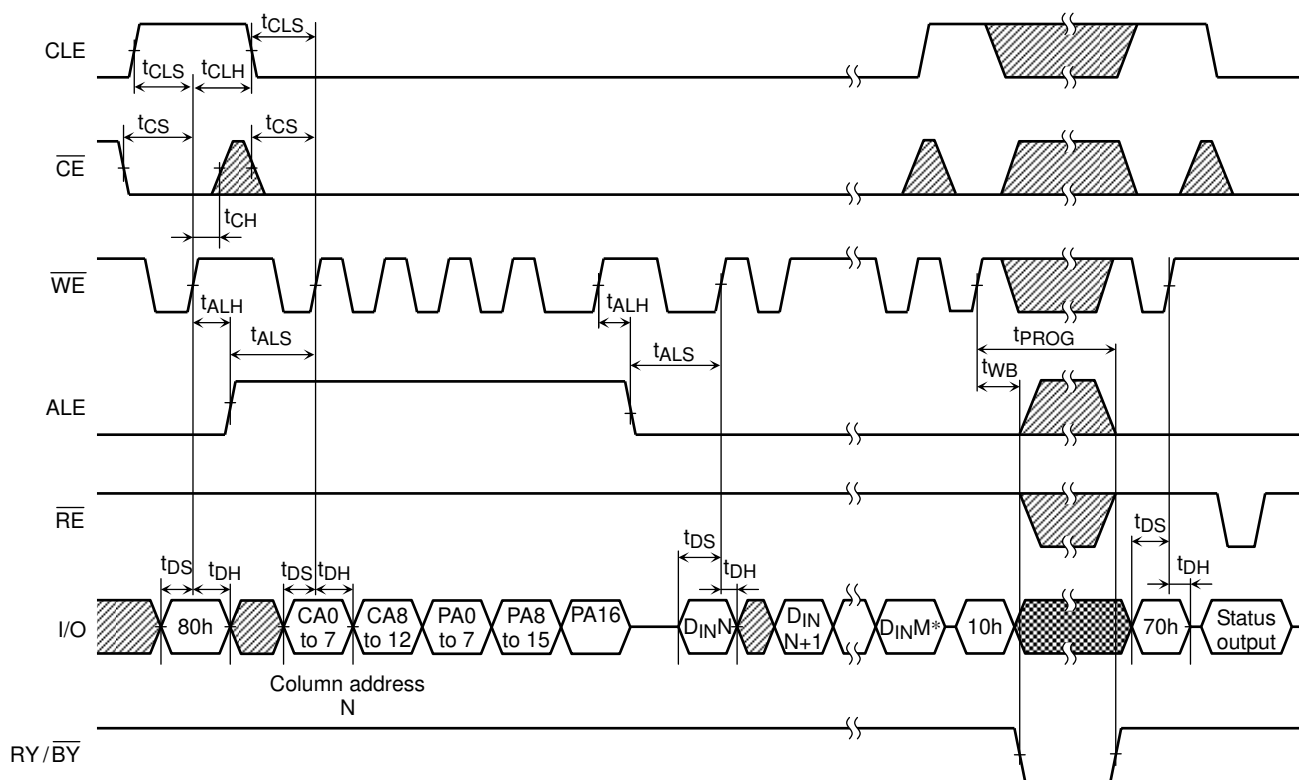

Auto-Program Operation Timing Diagram



 : Do not input data while data is being output.

 : V_{IH} or V_{IL}

*) M: up to 4351 (byte input data for $\times 8$ device).

Auto-Program Operation with Data Cache Timing Diagram (1/3)

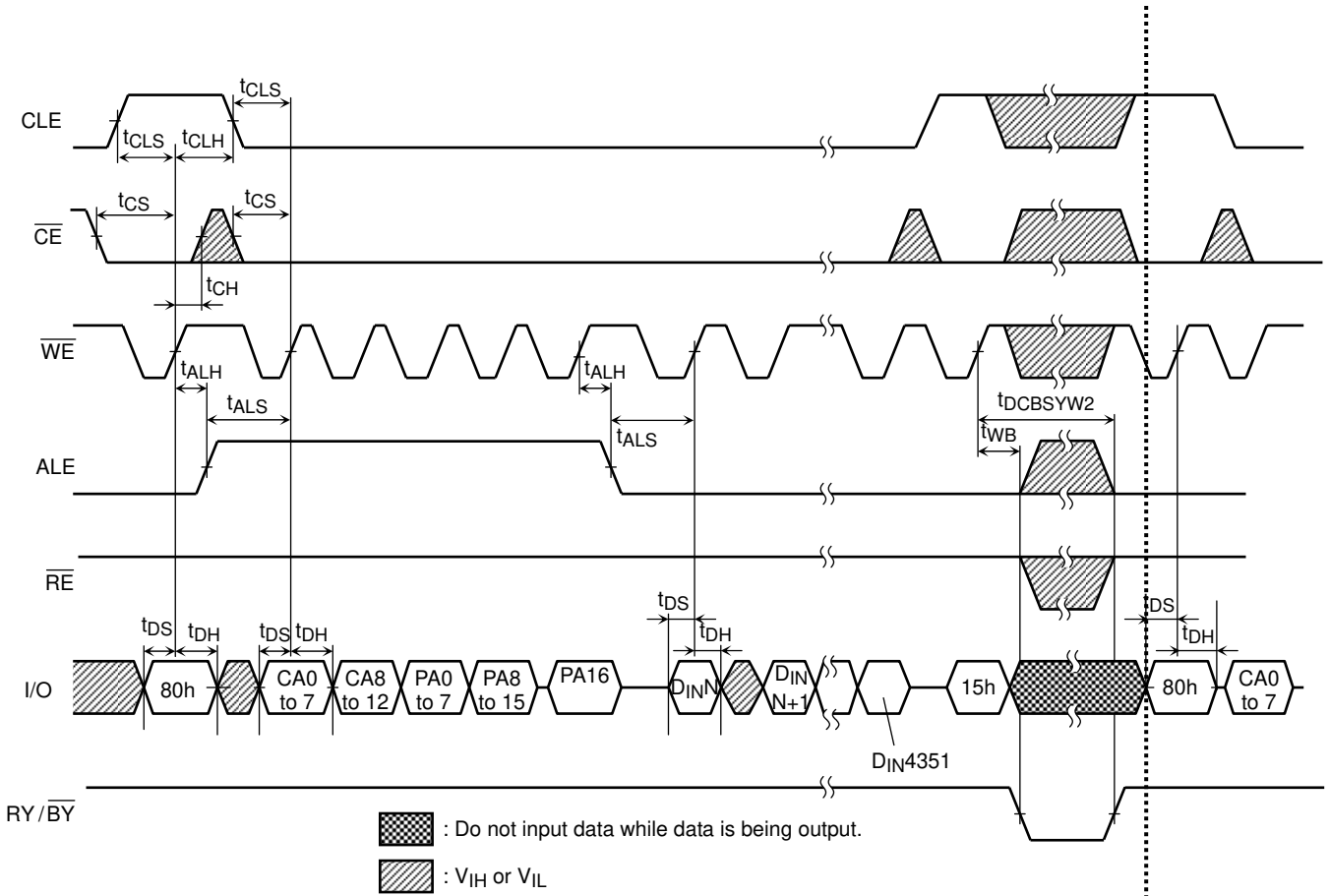

CA0 to CA12 is 0 in this diagram.

1

Continues to 1 of next page

Auto-Program Operation with Data Cache Timing Diagram (2/3)

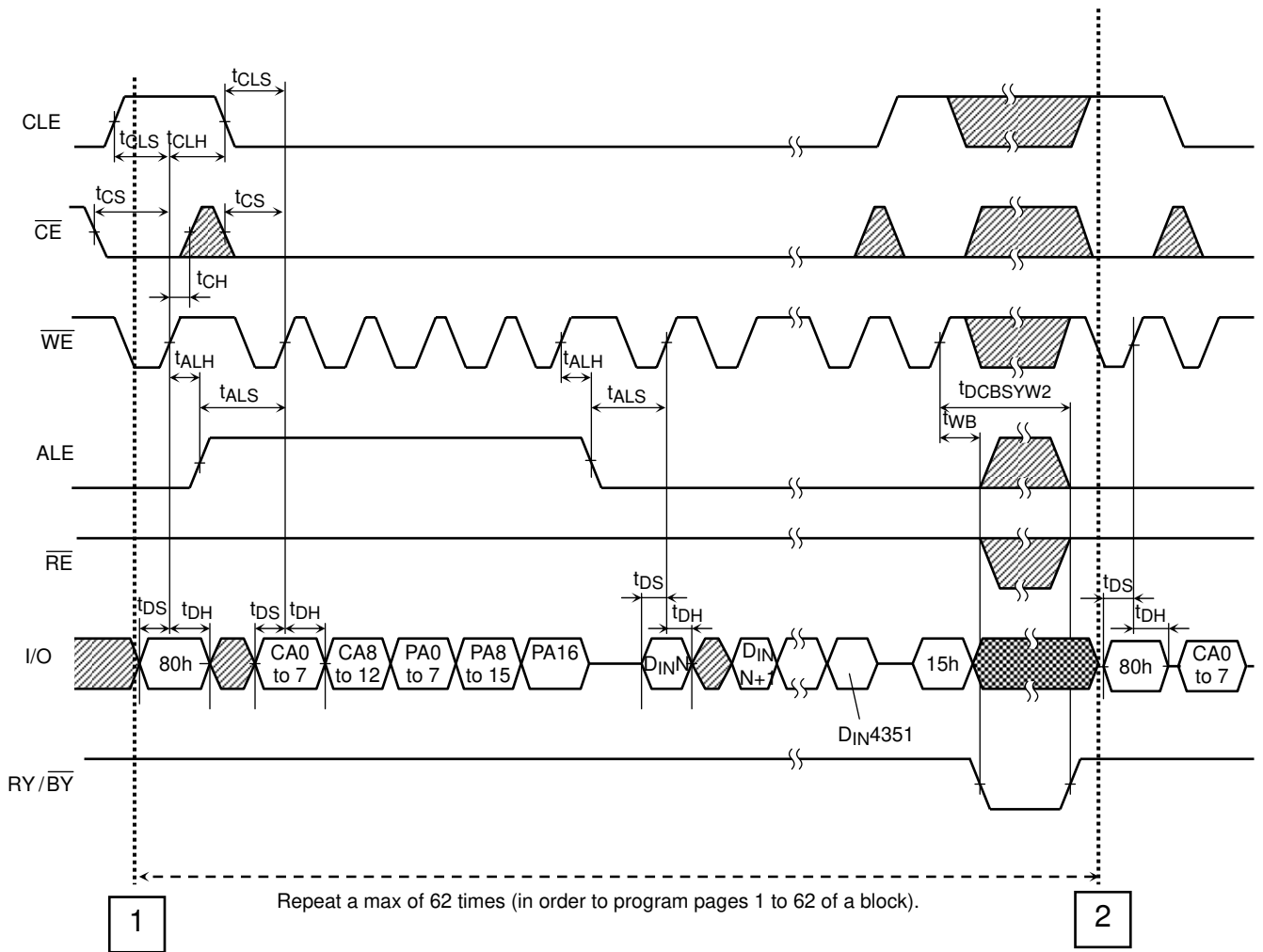

Continues from **1** of previous page

Continues to **2** of next page

- : Do not input data while data is being output.
- : V_{IH} or V_{IL}

Auto-Program Operation with Data Cache Timing Diagram (3/3)

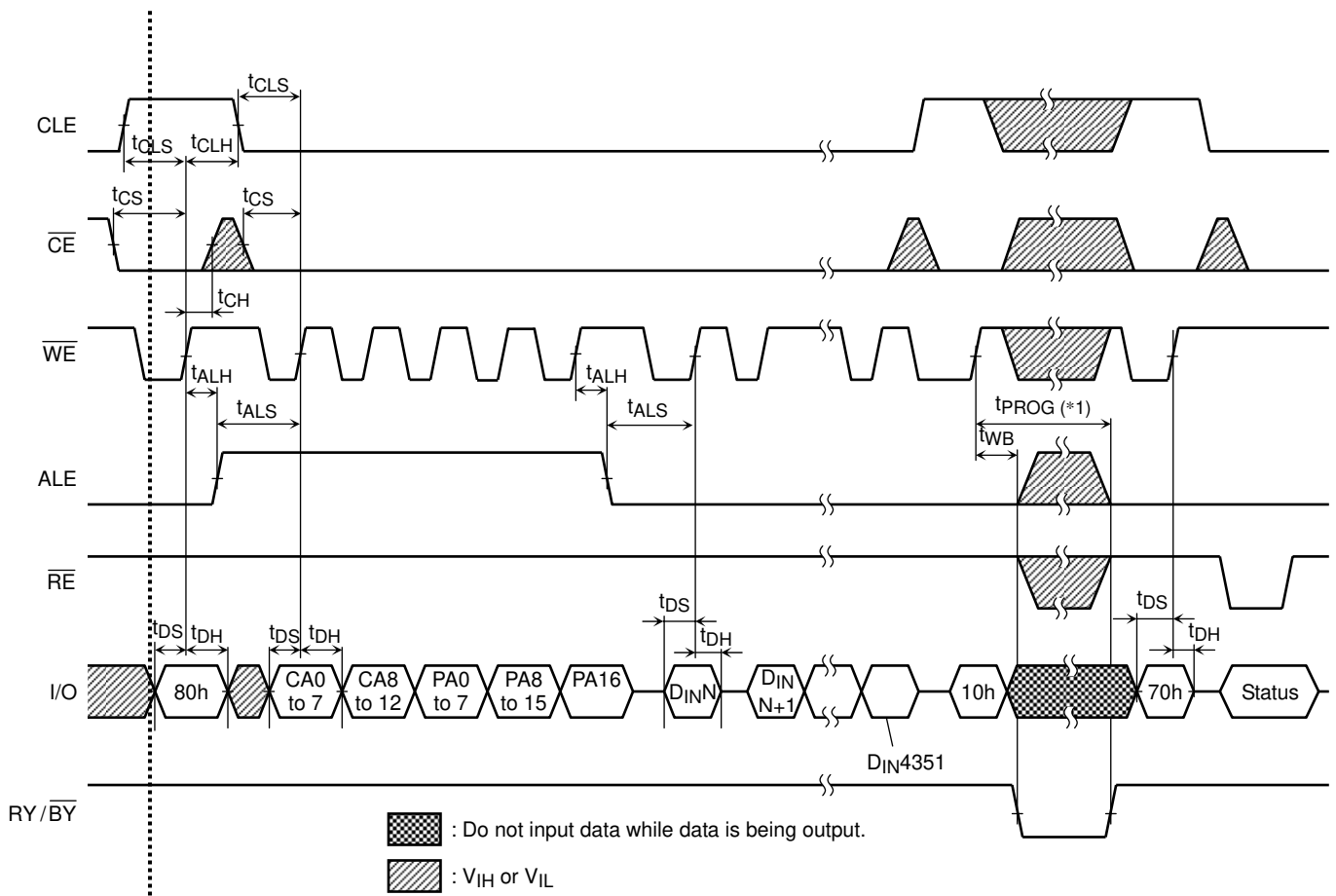

2

Continues from 2 of previous page

(*1) t_{PROG} : Since the last page programming by 10h command is initiated after the previous cache program, the t_{PROG} during cache programming is given by the following equation.

$$t_{PROG} = t_{PROG} \text{ of the last page} + t_{PROG} \text{ of the previous page} - A$$

$$A = (\text{command input cycle} + \text{address input cycle} + \text{data input cycle time of the last page})$$

If "A" exceeds the t_{PROG} of previous page, t_{PROG} of the last page is $t_{PROG} \text{ max.}$

(Note) Make sure to terminate the operation with 80h-10h- command sequence.
 If the operation is terminated by 80h-15h command sequence, monitor I/O 6 (Ready / Busy) by issuing Status Read command (70h) and make sure the previous page program operation is completed. If the page program operation is completed issue FFh reset before next operation.

Multi-Page Program Operation with Data Cache Timing Diagram (1/4)

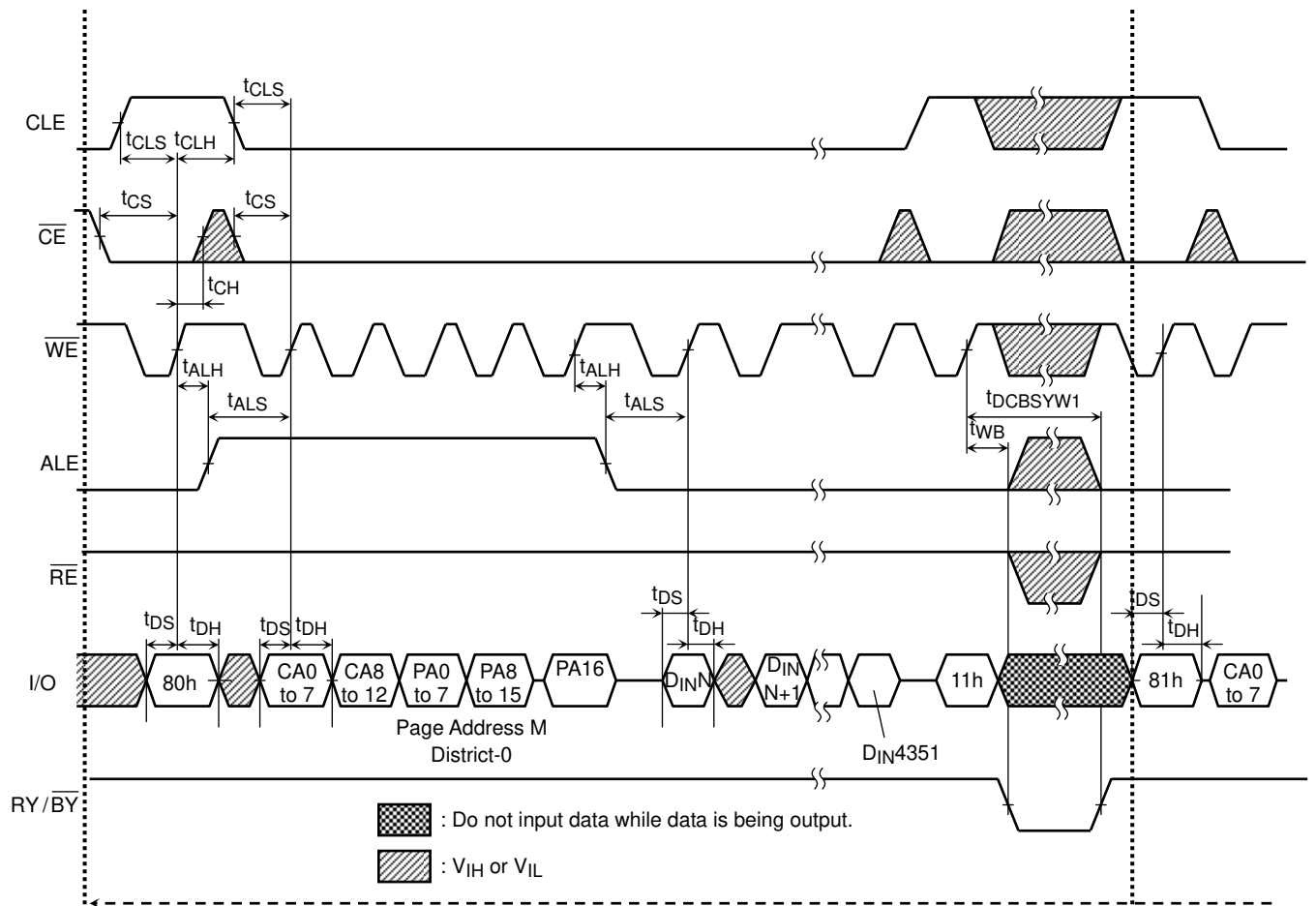

1

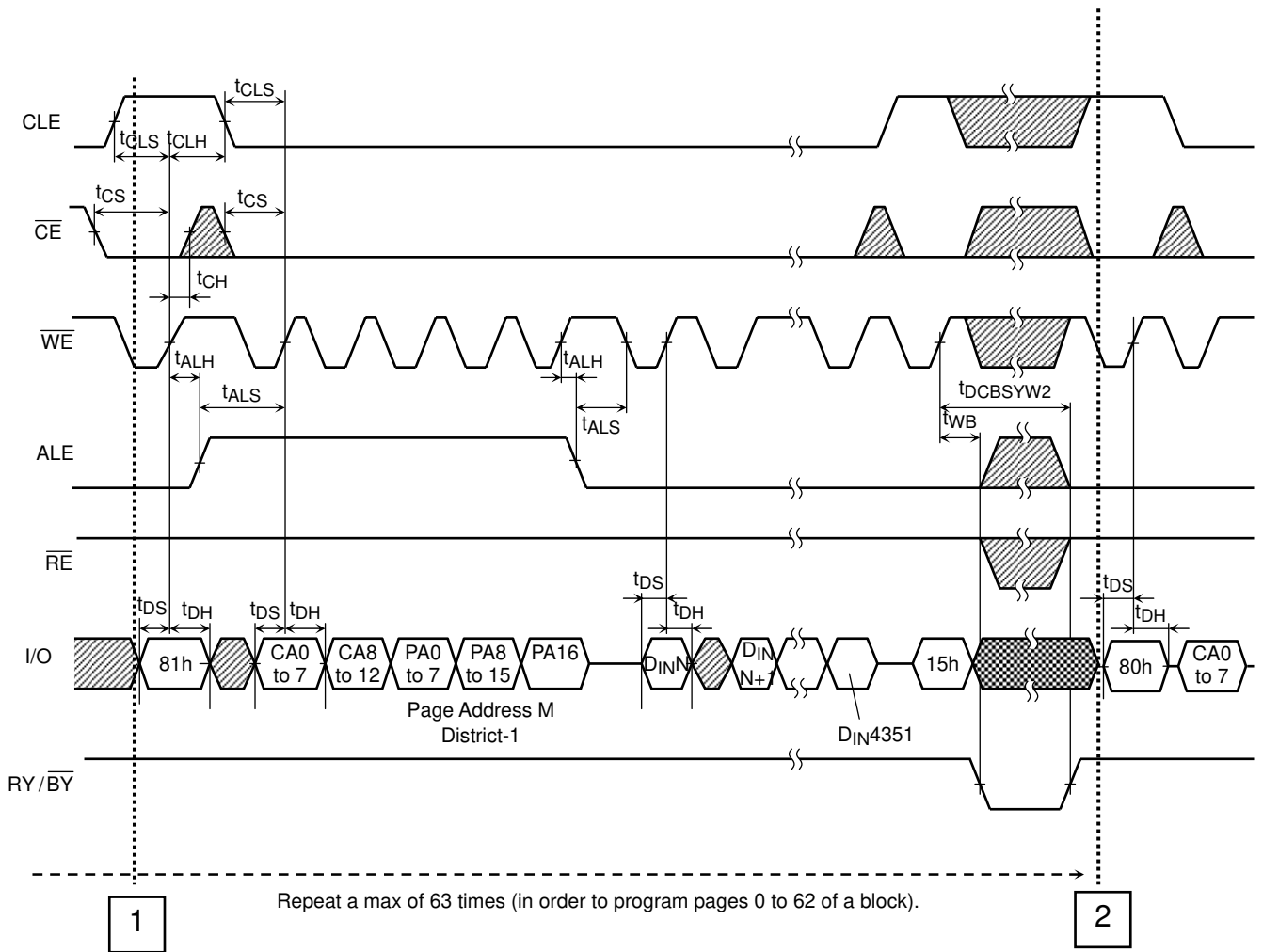

Continues to 1 of next page

Multi-Page Program Operation with Data Cache Timing Diagram (2/4)



Continues from **1** of previous page

Continues to **2** of next page

-  : Do not input data while data is being output.
-  : V_{IH} or V_{IL}

Multi-Page Program Operation with Data Cache Timing Diagram (3/4)

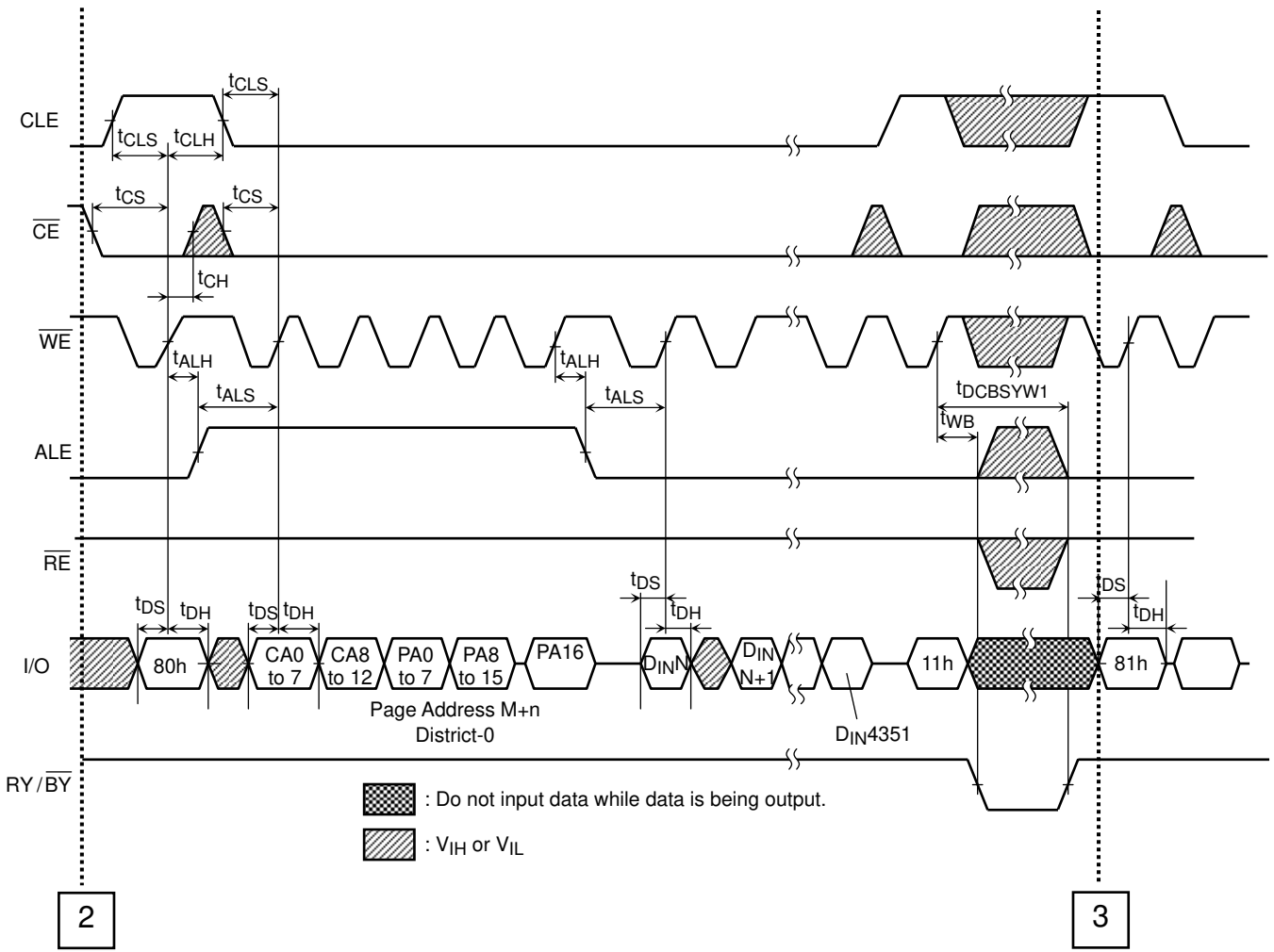

Continues from 2 of previous page

Continues to 3 of next page

Multi-Page Program Operation with Data Cache Timing Diagram (4/4)

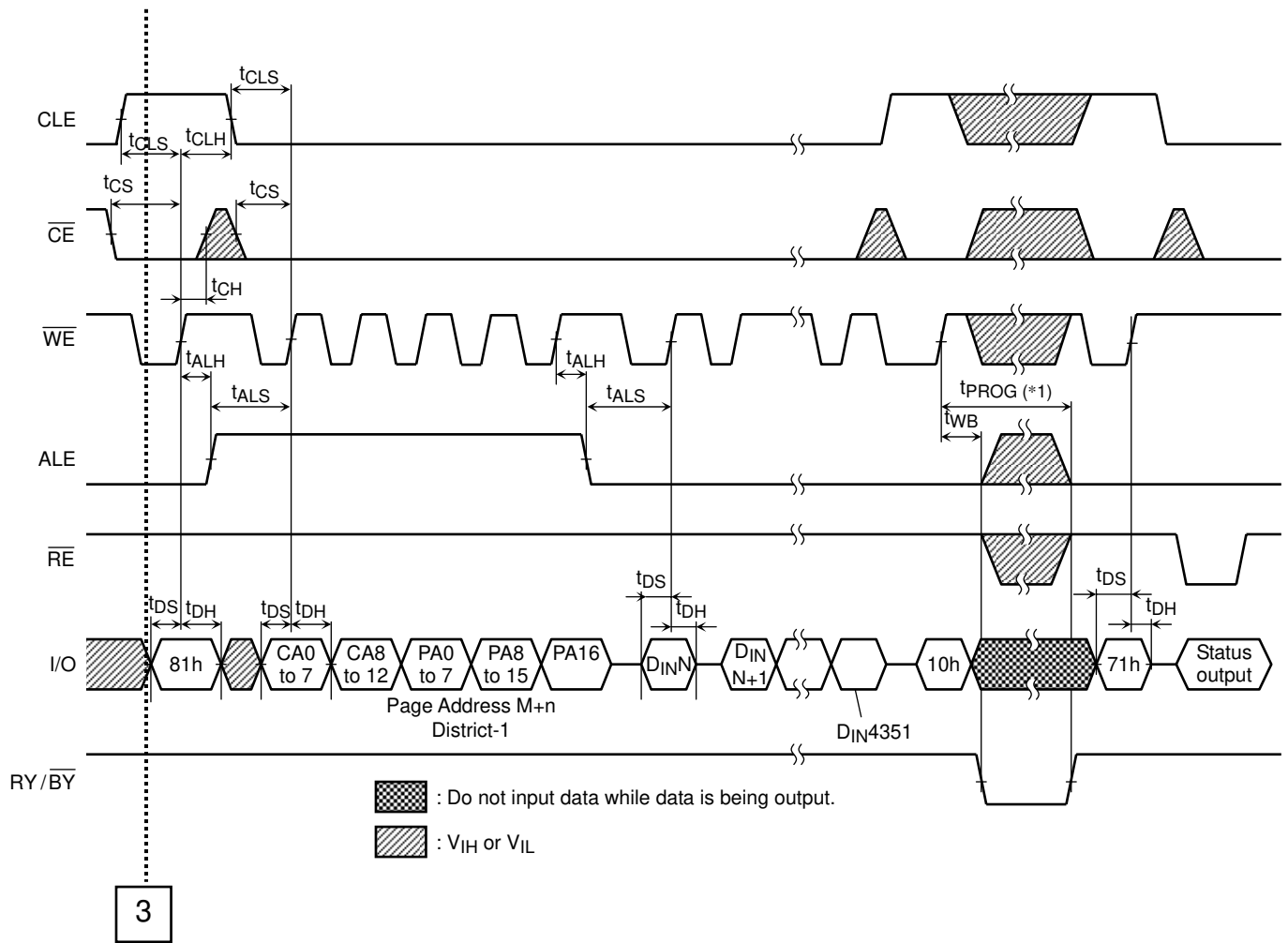

Continues from **3** of previous page

(*1) t_{PROG} : Since the last page programming by 10h command is initiated after the previous cache program, the t_{PROG} during cache programming is given by the following equation.

$$t_{PROG} = t_{PROG} \text{ of the last page} + t_{PROG} \text{ of the previous page} - A$$

$$A = (\text{command input cycle} + \text{address input cycle} + \text{data input cycle time of the last page})$$

If "A" exceeds the t_{PROG} of previous page, t_{PROG} of the last page is $t_{PROG} \text{ max}$.

(Note) Make sure to terminate the operation with 81h-10h- command sequence.
 If the operation is terminated by 81h-15h command sequence, monitor I/O 6 (Ready / Busy) by issuing Status Read command (70h) and make sure the previous page program operation is completed. If the page program operation is completed issue FFh reset before next operation.

Auto Block Erase Timing Diagram

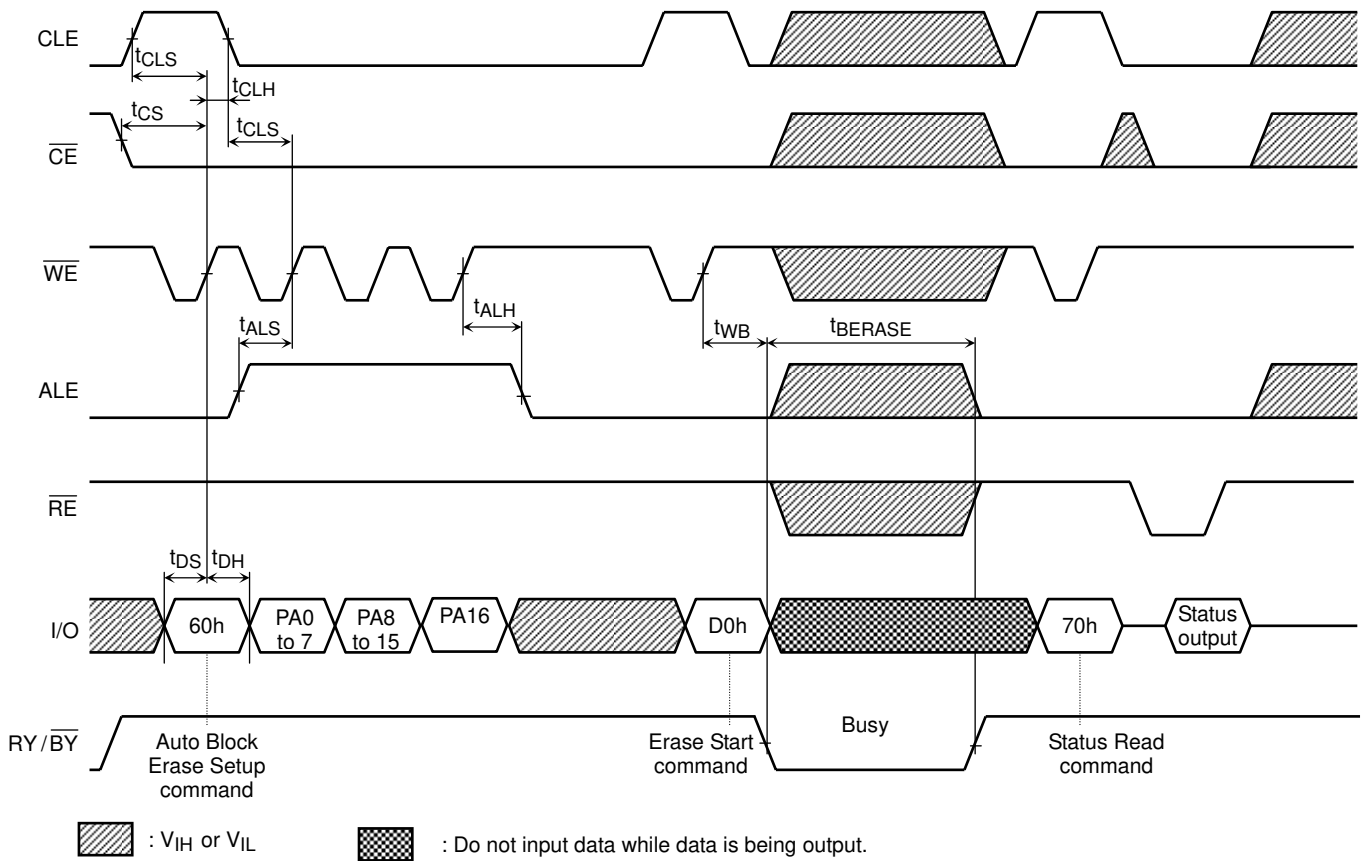

Multi Block Erase Timing Diagram

