



Chipsmall Limited consists of a professional team with an average of over 10 year of expertise in the distribution of electronic components. Based in Hongkong, we have already established firm and mutual-benefit business relationships with customers from,Europe,America and south Asia,supplying obsolete and hard-to-find components to meet their specific needs.

With the principle of “Quality Parts,Customers Priority,Honest Operation,and Considerate Service”,our business mainly focus on the distribution of electronic components. Line cards we deal with include Microchip,ALPS,ROHM,Xilinx,Pulse,ON,Everlight and Freescale. Main products comprise IC,Modules,Potentiometer,IC Socket,Relay,Connector.Our parts cover such applications as commercial,industrial, and automotives areas.

We are looking forward to setting up business relationship with you and hope to provide you with the best service and solution. Let us make a better world for our industry!



Contact us

Tel: +86-755-8981 8866 Fax: +86-755-8427 6832

Email & Skype: info@chipsmall.com Web: www.chipsmall.com

Address: A1208, Overseas Decoration Building, #122 Zhenhua RD., Futian, Shenzhen, China



Six Pair, N- and P-Channel Enhancement-Mode MOSFET

Features

- ▶ High voltage, vertical DMOS technology
- ▶ Integrated gate-to-source resistor
- ▶ Integrated gate-to-source Zener diode
- ▶ Typical peak output +/-3.5A at 50V
- ▶ Low threshold, low on-resistance
- ▶ Low input & output capacitance
- ▶ Fast switching speeds
- ▶ Electrically isolated N- and P-MOSFET pairs

Applications

- ▶ High voltage pulsers
- ▶ Amplifiers
- ▶ Buffers
- ▶ Piezoelectric transducer drivers
- ▶ General purpose line drivers
- ▶ Logic level interfaces

General Description

The Supertex TC8020 consists of six pairs of high voltage, low threshold N- and P-channel MOSFETs in a 56-lead QFN package. All MOSFETs have integrated gate-to-source resistors and gate-to-source Zener diode clamps which are desired for high voltage pulser applications. The complimentary, high-speed, high voltage, gate-clamped N- and P-channel MOSFET pairs utilize an advanced vertical DMOS structure and Supertex's well-proven silicon-gate manufacturing process. This combination produces a device with the power handling capabilities of bipolar transistors and with the high input impedance and positive temperature coefficient inherent in MOS devices.

Characteristic of all MOS structures, this device is free from thermal runaway and thermally-induced secondary breakdown. Supertex's vertical DMOS FETs are ideally suited to a wide range of switching and amplifying applications where very low threshold voltage, high breakdown voltage, high input impedance, low input and output capacitance, and fast switching speeds are desired.

Typical Application

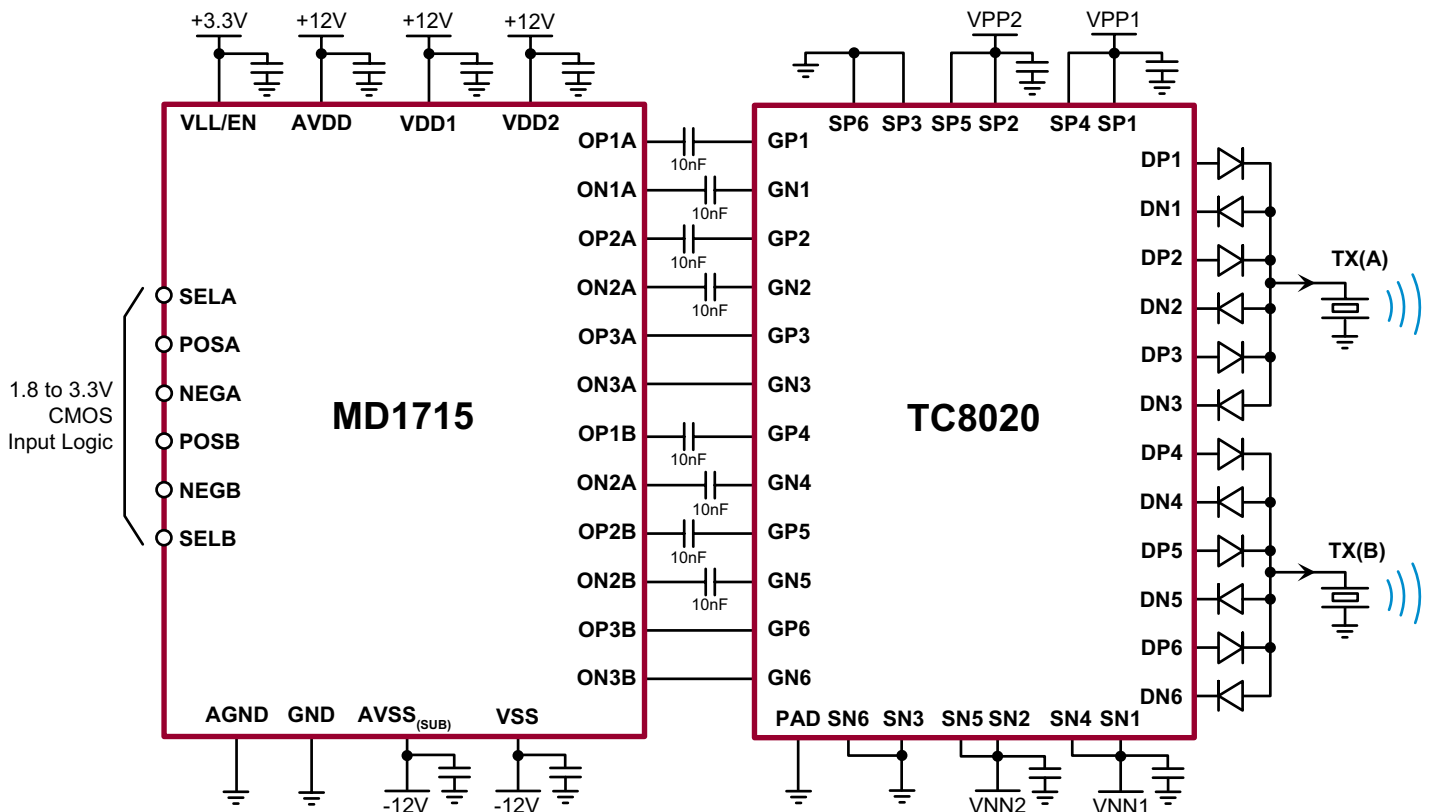

Ordering Information

Part Number	Package Option	Packing
TC8020K6-G	56-Lead QFN (8x8)	250/Tray

-G indicates package is RoHS compliant ('Green')



Product Summary

BV_{DSS}/BV_{DGS} (V)		$R_{DS(ON)}$ (max) (Ω)	
N-Channel	P-Channel	N-Channel	P-Channel
200	-200	8.0	9.5

Pin Configuration

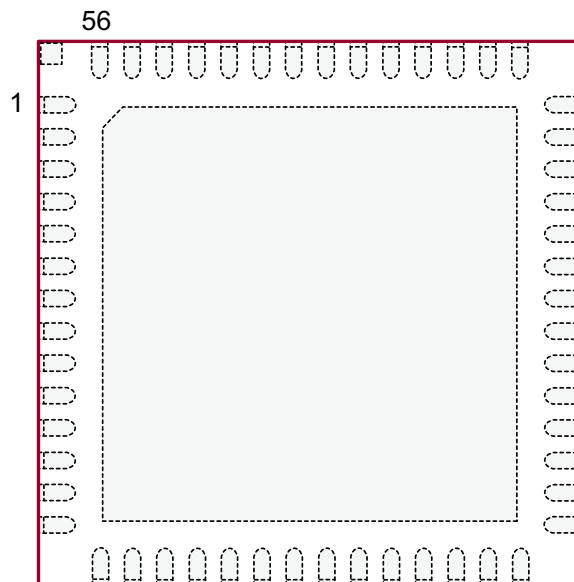

56-Lead QFN (K6)
Top View

Absolute Maximum Ratings

Parameter	Value
Drain-to-source voltage	BV_{DSS}
Drain-to-gate voltage	BV_{DGS}
Operating and storage temperature	-55°C to +150°C

Absolute Maximum Ratings are those values beyond which damage to the device may occur. Functional operation under these conditions is not implied. Continuous operation of the device at the absolute rating level may affect device reliability. All voltages are referenced to device ground.

* Distance of 1.6mm from case for 10 seconds.

Thermal Characteristics

Package	θ_{ja}
56-Lead QFN (K6)	27°C/W

Note:
1.0oz, 4-layer, 3"x4" PCB

Package Marking

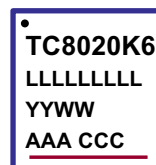

L = Lot Number
YY = Year Sealed
WW = Week Sealed
A = Assembler ID
C = Country of Origin
___ = "Green" Packaging

Package may or may not include the following marks: Si or

56-Lead QFN (K6)

N-Channel Electrical Characteristics ($T_A = 25^\circ\text{C}$ unless otherwise specified)

Sym	Parameter	Min	Typ	Max	Units	Conditions
BV_{DSS}	Drain-to-source breakdown voltage	200	-	-	V	$V_{GS} = 0V, I_D = 1.0mA$
$V_{GS(th)}$	Gate threshold voltage	1.0	-	2.4	V	$V_{GS} = V_{DS}, I_D = 1.0mA$
$\Delta V_{GS(th)}$	Change in $V_{GS(th)}$ with temperature	-	-	-4.5	mV/°C	$V_{GS} = V_{DS}, I_D = 1.0mA$
R_{GS}	Gate-to-source shunt resistor	5.0	-	26	K Ω	$I_{GS} = 100\mu A$
VZ_{GS}	Gate-to-source Zener voltage	13.2	-	25	V	$I_{GS} = 2.0mA$
I_{DSS}	Zero gate voltage drain current	-	-	10.0	μA	$V_{DS} = \text{Max rating}, V_{GS} = 0V$
		-	-	1.0	mA	$V_{DS} = 0.8 \text{ Max Rating}, V_{GS} = 0V, T_A = 125^\circ\text{C}$
$I_{D(ON)}$	On-state drain current	1.2	1.8	-	A	$V_{GS} = 4.5V, V_{DS} = 25V$
		2.0	3.2	-		$V_{GS} = 10V, V_{DS} = 25V$
$R_{DS(ON)}$	Static drain-to-source on-state resistance	-	6.0	9.0	Ω	$V_{GS} = 4.5V, I_D = 150mA$
		-	5.3	8.0		$V_{GS} = 10V, I_D = 1.0A$
$\Delta R_{DS(ON)}$	Change in $R_{DS(ON)}$ with temperature	-	-	1.0	%/°C	$V_{GS} = 10V, I_D = 1.0A$
G_{FS}	Forward transconductance	400	-	-	mmho	$V_{DS} = 25V, I_D = 500mA$
C_{ISS}	Input capacitance	-	50	-	pF	$V_{GS} = 0V, V_{DS} = 25V, f = 1.0MHz$
C_{OSS}	Common source output capacitance	-	18	-		
C_{RSS}	Reverse transfer capacitance	-	7.0	-		
$t_{d(ON)}$	Turn-on delay time	-	-	10	ns	$V_{DD} = 25V, I_D = 500mA, R_{GEN} = 25\Omega$
t_r	Rise time	-	-	15		
$t_{d(OFF)}$	Turn-off delay time	-	-	20		
t_f	Fall time	-	-	15		
V_{SD}	Diode forward voltage drop	-	-	1.8	V	$V_{GS} = 0V, I_{SD} = 500mA$
t_{rr}	Reverse recovery time	-	300	-	ns	$V_{GS} = 0V, I_{SD} = 500mA$

Notes:

1. All D.C. parameters 100% tested at 25°C unless otherwise stated. (Pulse test: 300µs pulse, 2% duty cycle.)
2. All A.C. parameters sample tested.

N-Channel Switching Waveforms and Test Circuit

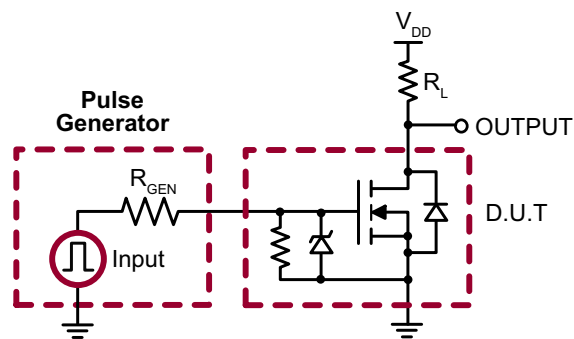
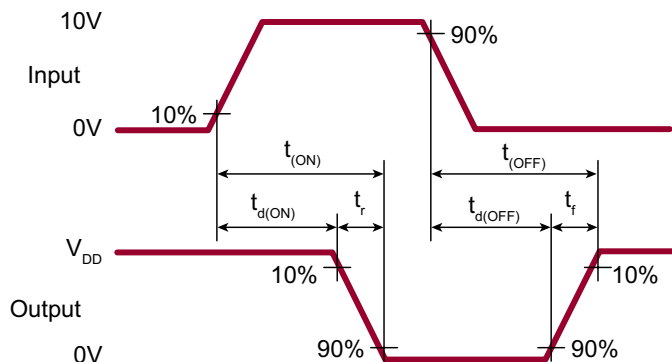

P-Channel Electrical Characteristics ($T_A = 25^\circ\text{C}$ unless otherwise specified)

Sym	Parameter	Min	Typ	Max	Units	Conditions
BV_{DSS}	Drain-to-source breakdown voltage	-200	-	-	V	$V_{GS} = 0V, I_D = -1.0mA$
$V_{GS(th)}$	Gate threshold voltage	-1.0	-	-2.4	V	$V_{GS} = V_{DS}, I_D = -1.0mA$
$\Delta V_{GS(th)}$	Change in $V_{GS(th)}$ with temperature	-	-	4.5	mV/°C	$V_{GS} = V_{DS}, I_D = -1.0mA$
R_{GS}	Gate-to-source shunt resistor	5.0	-	26	K Ω	$I_{GS} = -100\mu A$
VZ_{GS}	Gate-to-source Zener voltage	-13.2	-	-24.0	V	$I_{GS} = -2.0mA$
I_{DSS}	Zero gate voltage drain current	-	-	-10	μA	$V_{DS} = \text{Max rating}, V_{GS} = 0V$
		-	-	-1.0	mA	$V_{DS} = 0.8 \text{ Max Rating}, V_{GS} = 0V, T_A = 125^\circ\text{C}$
$I_{D(ON)}$	On-state drain current	-0.80	-1.25	-	A	$V_{GS} = -4.5V, V_{DS} = -25V$
		-2.00	-2.80	-		$V_{GS} = -10V, V_{DS} = -25V$
$R_{DS(ON)}$	Static drain-to-source on-state resistance	-	7.0	10	Ω	$V_{GS} = -4.5V, I_D = -150mA$
		-	6.5	9.5		$V_{GS} = -10V, I_D = -1.0A$
$\Delta R_{DS(ON)}$	Change in $R_{DS(ON)}$ with temperature	-	-	1.0	%/°C	$V_{GS} = -10V, I_D = -1.0A$
G_{FS}	Forward transconductance	400	-	-	mmho	$V_{DS} = -25V, I_D = -500mA$
C_{ISS}	Input capacitance	-	55	-	pF	$V_{GS} = 0V, V_{DS} = -25V, f = 1.0MHz$
C_{OSS}	Common source output capacitance	-	20	-		
C_{RSS}	Reverse transfer capacitance	-	8.0	-		
$t_{d(ON)}$	Turn-on delay time	-	-	10	ns	$V_{DD} = -25V, I_D = -1.0A, R_{GEN} = 25\Omega$
t_r	Rise time	-	-	15		
$t_{d(OFF)}$	Turn-off delay time	-	-	20		
t_f	Fall time	-	-	15		
V_{SD}	Diode forward voltage drop	-	-	-1.8	V	$V_{GS} = 0V, I_{SD} = -500mA$
t_{rr}	Reverse recovery time	-	300	-	ns	$V_{GS} = 0V, I_{SD} = -500mA$

Notes:

1. All D.C. parameters 100% tested at 25°C unless otherwise stated. (Pulse test: 300 μs pulse, 2% duty cycle.)
2. All A.C. parameters sample tested.

P-Channel Switching Waveforms and Test Circuit

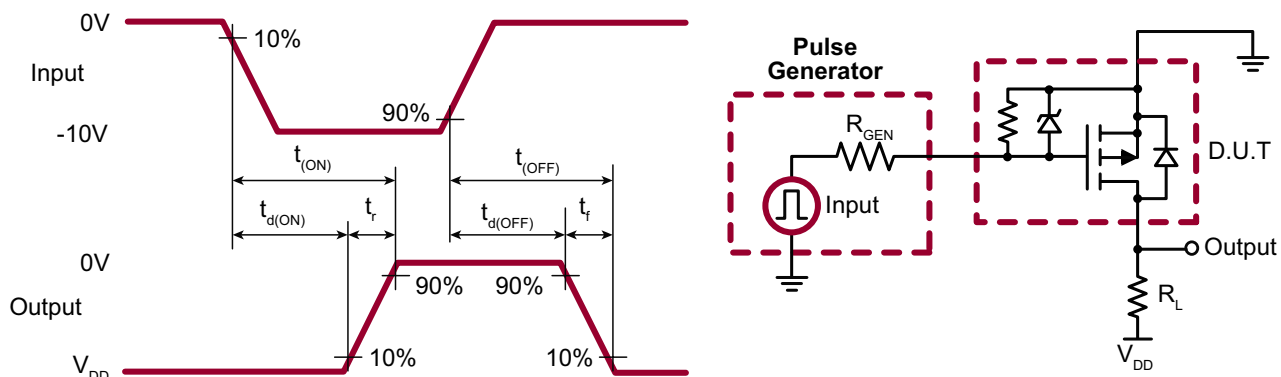

Circuit Pin Layout

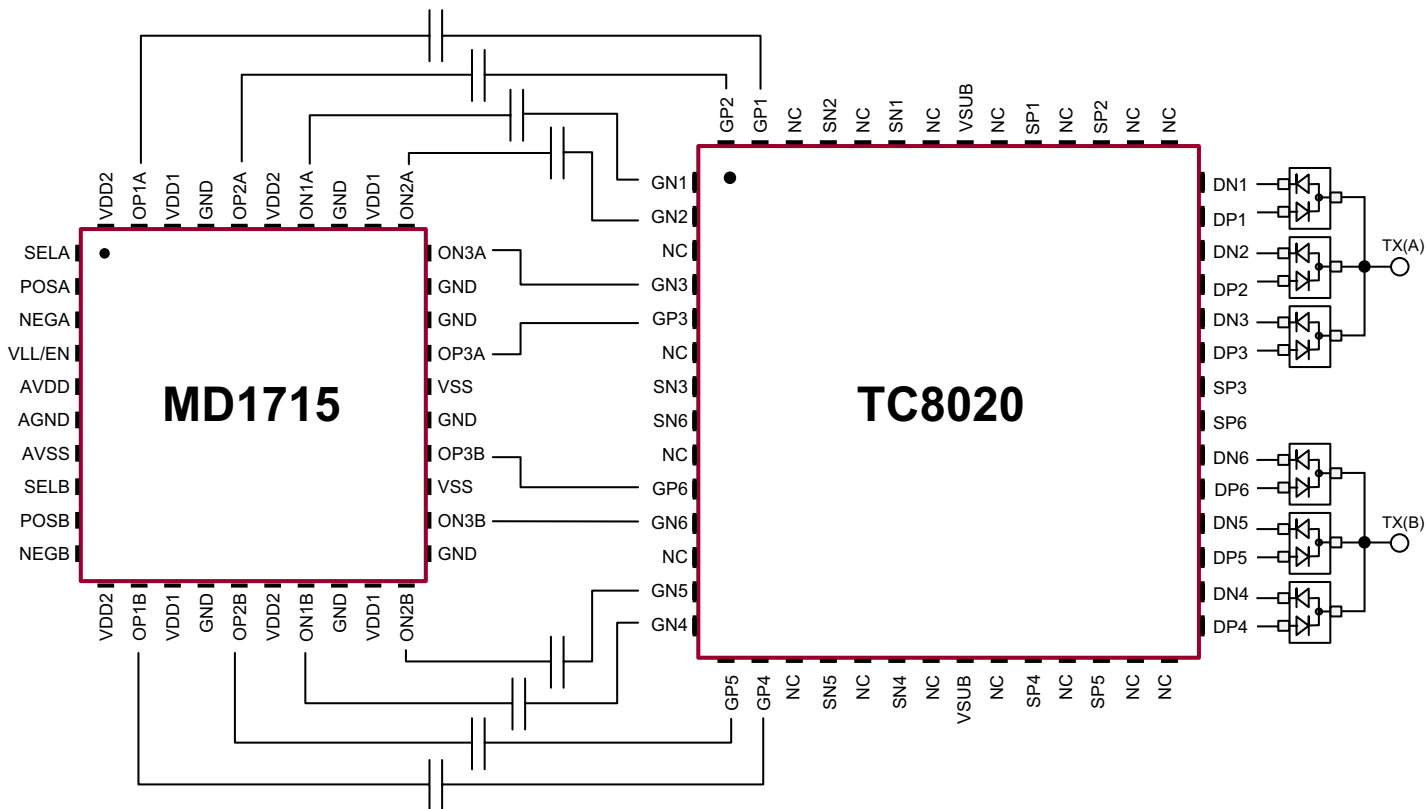

Pin Description

Pin	Function	Description
1	GN1	Gate of N-MOSFET 1
2	GN2	Gate of N-MOSFET 2
3	NC	No Connection
4	GN3	Gate of N-MOSFET 3
5	GP3	Gate of P-MOSFET 3
6	NC	No Connection
7	SN3	Source of N-MOSFET 3
8	SN6	Source of N-MOSFET 6
9	NC	No Connection
10	GP6	Gate of P-MOSFET 6
11	GN6	Gate of N-MOSFET 6
12	NC	No Connection
13	GN5	Gate of N-MOSFET 5
14	GN4	Gate of N-MOSFET 4
15	GP5	Gate of P-MOSFET 5
16	GP4	Gate of P-MOSFET 4
17	NC	No Connection
18	SN5	Source of N-MOSFET 5

Pin Description (cont.)

Pin	Function	Description
19	NC	No Connection
20	SN4	Source of N-MOSFET 4
21	NC	No Connection
22	VSUB	Die attachment substrate, must be grounded externally.
23	NC	No Connection
24	SP4	Source of P-MOSFET 4
25	NC	No Connection
26	SP5	Source of P-MOSFET 5
27	NC	No Connection
28	NC	No Connection
29	DP4	Drain of P-MOSFET 4
30	DN4	Drain of N-MOSFET 4
31	DP5	Drain of P-MOSFET 5
32	DN5	Drain of N-MOSFET 5
33	DP6	Drain of P-MOSFET 6
34	DN6	Drain of N-MOSFET 6
35	SP6	Source of P-MOSFET 6
36	SP3	Source of P-MOSFET 3
37	DP3	Drain of P-MOSFET 3
38	DN3	Drain of N-MOSFET 3
39	DP2	Drain of P-MOSFET 2
40	DN2	Drain of N-MOSFET 2
41	DP1	Drain of P-MOSFET 1
42	DN1	Drain of N-MOSFET 1
43	NC	No Connection
44	NC	No Connection
45	SP2	Source of P-MOSFET 2
46	NC	No Connection
47	SP1	Source of P-MOSFET 1
48	NC	No Connection
49	VSUB	Die attachment substrate, must be grounded externally.
50	NC	No Connection
51	SN1	Source of N-MOSFET 1
52	NC	No Connection
53	SN2	Source of N-MOSFET 2
54	NC	No Connection
55	GP1	Gate of P-MOSFET 1
56	GP2	Gate of P-MOSFET 2

Note:

Thermal Pad must be grounded externally.

56-Lead QFN Package Outline (K6)

8.00x8.00mm body, 1.00mm height (max), 0.50mm pitch

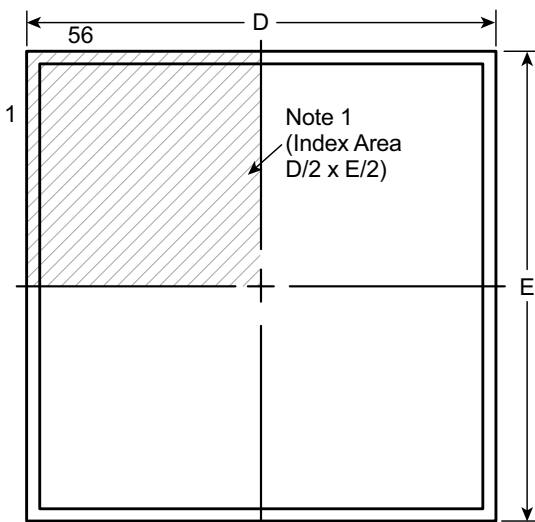

Top View

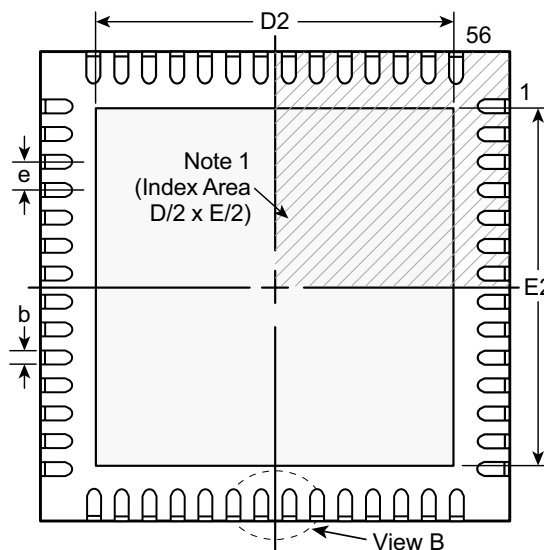

Bottom View

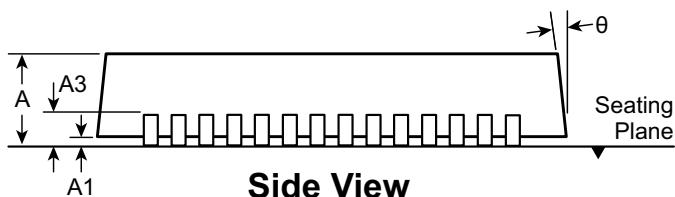

Side View

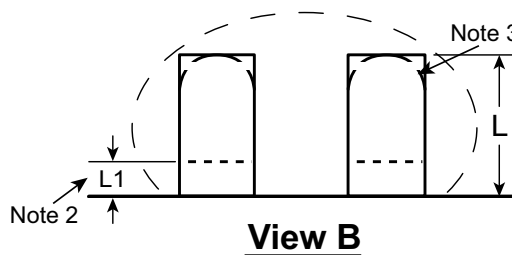

View B

Notes:

1. A Pin 1 identifier must be located in the index area indicated. The Pin 1 identifier can be: a molded mark/identifier; an embedded metal marker; or a printed indicator.
2. Depending on the method of manufacturing, a maximum of 0.15mm pullback (L1) may be present.
3. The inner tip of the lead may be either rounded or square.

Symbol	A	A1	A3	b	D	D2	E	E2	e	L	L1	θ	
Dimension (mm)	MIN	0.80	0.00	0.20 REF	0.18	7.85*	2.75	7.85*	2.75	0.50 BSC	0.30	0.00	0°
	NOM	0.90	0.02		0.25	8.00	5.70	8.00	5.70		0.40	-	-
	MAX	1.00	0.05		0.30	8.15*	6.70†	8.15*	6.70†		0.50	0.15	14°

JEDEC Registration MO-220, Variation VLLD-2, Issue K, June 2006.

* This dimension is not specified in the JEDEC drawing.

† This dimension differs from the JEDEC drawing.

Drawings are not to scale.

Supertex Doc.#: DSPD-56QFNK68X8P050, Version A031010.

(The package drawing(s) in this data sheet may not reflect the most current specifications. For the latest package outline information go to <http://www.supertex.com/packaging.html>.)

Supertex inc. does not recommend the use of its products in life support applications, and will not knowingly sell them for use in such applications unless it receives an adequate "product liability indemnification insurance agreement." **Supertex inc.** does not assume responsibility for use of devices described, and limits its liability to the replacement of the devices determined defective due to workmanship. No responsibility is assumed for possible omissions and inaccuracies. Circuitry and specifications are subject to change without notice. For the latest product specifications refer to the **Supertex inc.** (website: <http://www.supertex.com>)