



Chipsmall Limited consists of a professional team with an average of over 10 year of expertise in the distribution of electronic components. Based in Hongkong, we have already established firm and mutual-benefit business relationships with customers from,Europe,America and south Asia,supplying obsolete and hard-to-find components to meet their specific needs.

With the principle of "Quality Parts,Customers Priority,Honest Operation,and Considerate Service",our business mainly focus on the distribution of electronic components. Line cards we deal with include Microchip,ALPS,ROHM,Xilinx,Pulse,ON,Everlight and Freescale. Main products comprise IC,Modules,Potentiometer,IC Socket,Relay,Connector.Our parts cover such applications as commercial,industrial, and automotives areas.

We are looking forward to setting up business relationship with you and hope to provide you with the best service and solution. Let us make a better world for our industry!



## Contact us

Tel: +86-755-8981 8866 Fax: +86-755-8427 6832

Email & Skype: info@chipsmall.com Web: www.chipsmall.com

Address: A1208, Overseas Decoration Building, #122 Zhenhua RD., Futian, Shenzhen, China



TCFS-\*\*-\*\*\*-0\*\*-25CH

a) Part as supplied.

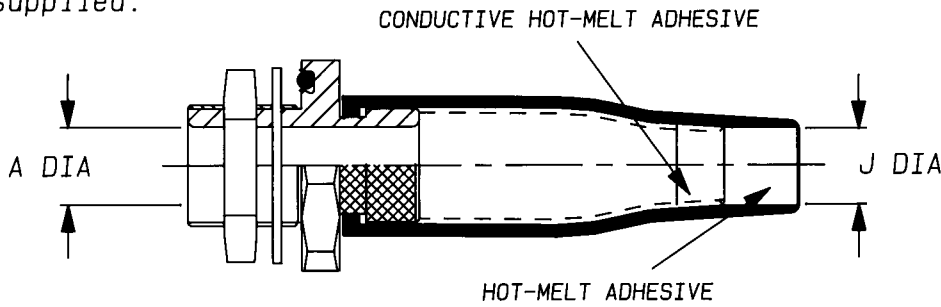

b) Part after unrestricted recovery.

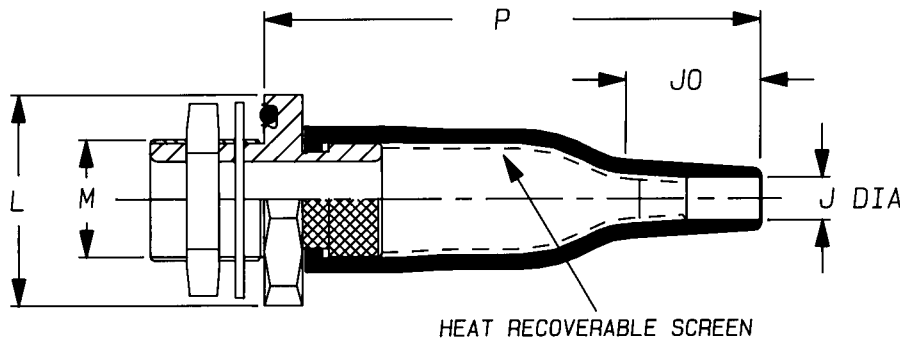

KITS TO INCLUDE CLEANING TISSUE, 1 PIECE 100 GRIT EMERY CLOTH & 1 PIECE OF ATUM.  
KIT TO BE USED IN CONJUNCTION WITH TCFS INSTALLATION PROCEDURE.

Dimensions (in millimetres)

PART No.	A	J	M	A/F	L	P	JO	
	min	min	max	THREAD	Nut	NOM	±10%	Ref
		a	b				b	b
TCFS-12	7.4	8	5.0	M12 x 1.5	17	24	50	15
TCFS-16	10.1	13	6.0	M16 x 1.5	22	29	65	17
TCFS-20	14.1	15	7.2	M20 x 1.5	27	34	77	20
TCFS-24	19.1	19	8.5	M24 x 1.5	30	38	90	25
TCFS-30	24.1	24	10.0	M30 x 1.5	36	47	115	30
TCFS-36	30.1	33	15.8	M36 x 1.5	41	52	140	30

Copyright (!)

Urheberrechte

The copyright in this drawing is the property of Raychem Ltd. The drawing is issued on condition that it is not copied, reproduced or disclosed to a third party, either in whole or in part without the prior written consent of Raychem Ltd.

Drawn A.LILLEY. Checked *[Signature]* Issue 5 Date November 1992 Conforms to ISO Recommendations

Approval  
Design

*[Handwritten signatures and initials]*

G.C. *[Signature]*

3rd Angle Projection  
Not to Scale

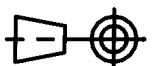

Iss.	Date	E.C.R. No.	Details of Change
2	February 1987	5028	ADHESIVE CHANGED
3	January 1989	5438	Ja CHANGED
4	October 1991	H0044	L was %
5	November 1992	H0125	S/S 30 L WAS 48

Material

(-25) DIESEL RESISTANT ELASTOMER

Part Numbering System.

TCFS-\*\*-\*\*\*-0\*\*-25CH

