



Chipsmall Limited consists of a professional team with an average of over 10 year of expertise in the distribution of electronic components. Based in Hongkong, we have already established firm and mutual-benefit business relationships with customers from,Europe,America and south Asia,supplying obsolete and hard-to-find components to meet their specific needs.

With the principle of "Quality Parts,Customers Priority,Honest Operation,and Considerate Service",our business mainly focus on the distribution of electronic components. Line cards we deal with include Microchip,ALPS,ROHM,Xilinx,Pulse,ON,Everlight and Freescale. Main products comprise IC,Modules,Potentiometer,IC Socket,Relay,Connector.Our parts cover such applications as commercial,industrial, and automotives areas.

We are looking forward to setting up business relationship with you and hope to provide you with the best service and solution. Let us make a better world for our industry!



Contact us

Tel: +86-755-8981 8866 Fax: +86-755-8427 6832

Email & Skype: info@chipsmall.com Web: www.chipsmall.com

Address: A1208, Overseas Decoration Building, #122 Zhenhua RD., Futian, Shenzhen, China



SPEC

Spec No.	TQ3C-8EAF0-E1YAL05-00
Date	January 12, 2013

TYPE : TCG121XGLP*PFA-AA*39

<12.1 inch XGA transmissive color TFT with LED backlight,
constant current circuit for LED backlight and touch panel>

CONTENTS

1. Application
2. Construction and outline
3. Mechanical specifications
4. Absolute maximum ratings
5. Electrical characteristics
6. Optical characteristics
7. Interface signals
8. Input timing characteristics
9. Design guidance for analog touch panel
10. Lot number identification
11. Warranty
12. Precautions for use
13. Reliability test data
14. Outline drawing

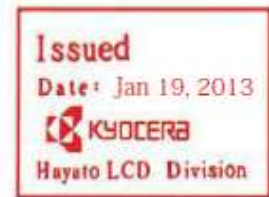

KYOCERA CORPORATION
LCD DIVISION

This specification is subject to change without notice.
Consult Kyocera before ordering.

Original Issue Date	Designed by: Engineering dept.			Confirmed by: QA dept.	
	Prepared	Checked	Approved	Checked	Approved
January 12, 2013	<i>H. Mori</i>	<i>Y. Yamazaki</i>	<i>M. Fujitani</i>	<i>I. Hamada</i>	<i>T. Itoh</i>

Spec No. TQ3C-8EAF0-E1YAL05-00	Part No. TCG121XGLP*PFA-AA*39	Page -
-----------------------------------	----------------------------------	-----------

Warning

1. This Kyocera LCD module has been specifically designed for use only in electronic devices and industrial machines in the area of audio control, office automation, industrial control, home appliances, etc. The module should not be used in applications where the highest level of safety and reliability are required and module failure or malfunction of such module results in physical harm or loss of life, as well as enormous damage or loss. Such fields of applications include, without limitation, medical, aerospace, communications infrastructure, atomic energy control. Kyocera expressly disclaims any and all liability resulting in any way to the use of the module in such applications.

2. Customer agrees to indemnify, defend and hold Kyocera harmless from and against any and all actions, claims, damages, liabilities, awards, costs, and expenses, including legal expenses, resulting from or arising out of Customer's use, or sale for use, or Kyocera modules in applications.

Caution

1. Kyocera shall have the right, which Customer hereby acknowledges, to immediately scrap or destroy tooling for Kyocera modules for which no Purchase Orders have been received from the Customer in a two-year period.

Spec No. TQ3C-8EAF0-E1YAL05-00	Part No. TCG121XGLP*PFA-AA*39	Page -
-----------------------------------	----------------------------------	-----------

Revision record

Date		Designed by : Engineering dept.			Confirmed by : QA dept.	
		Prepared	Checked	Approved	Checked	Approved
Rev.No.	Date	Page	Descriptions			

1. Application

This document defines the specification of TCG121XGLP*PFA-AA*39. (RoHS Compliant)

2. Construction and outline

LCD	: Transmissive color dot matrix type TFT
Backlight system	: LED
Polarizer	: Anti-Glare treatment
Interface	: LVDS
Additional circuit	: Timing controller, Power supply (3.3V input) With constant current circuit for LED Backlight(12V input)
Touch panel	: Analog type, Non-Glare treatment

3. Mechanical specifications

3-1. LCD

Item	Specification	Unit
Outline dimensions 1)	260.5(W)×(203.4)(H)×12.6(D)	mm
Active area	245.76(W)×184.32(H) (30.8cm/12.1 inch(Diagonal))	mm
Dot format	1,024×(B,G,R)(W)×768(H)	dot
Dot pitch	0.08(W)×0.24(H)	mm
Base color 2)	Normally Black	-
Mass	(TBD)	g

1) Projection not included. Please refer to outline for details.

2) Due to the characteristics of the LCD material, the color varies with environmental temperature.

3-2. Touch panel

Item	Specification	Unit
Input	Radius-0.8 stylus or Finger	-
Actuation Force	0.05 ~ 0.8	N
Transmittance	Typ. 80	%
Surface hardness	Pencil hardness 2H or more according	-

4. Absolute maximum ratings

4-1. Electrical absolute maximum ratings

Item		Symbol	Min.	Max.	Unit
Supply voltage(+3.3V)		V _{DD}	(-0.3)	(3.95)	V
Supply voltage(+12V)		V _{IN}	(-0.3)	(14.0)	V
Input signal Voltage 1)	RxINi+, RxINi- (i=0,1,2,3)	V _{I1}	(-0.3)	(V _{DD} +0.3)	V
	CK IN+, CK IN-	V _{I2}	(-0.3)	(V _{DD} +0.3)	V
	MODE, SC	V _{I3}	(-0.3)	(V _{DD} +0.3)	V
	BLBRT, BLEN	V _{I4}	(-0.3)	(V _{IN})	V
Supply voltage for touch panel		V _{TP}	0	6.0	V
Input current of touch panel		I _{TP}	0	5.0	mA

- 1) V_{DD} must be supplied correctly within the range described in 5-1.

4-2. Environmental absolute maximum ratings

Item	Symbol	Min.	Max.	Unit
Operating temperature 1)	T _{OP}	-30	80	°C
Storage temperature 2)	T _{STO}	-30	80	°C
Operating humidity 3)	H _{OP}	10	4)	%RH
Storage humidity 3)	H _{STO}	10	4)	%RH
Vibration	-	5)	5)	-
Shock	-	6)	6)	-

- 1) Operating temperature means a temperature which operation shall be guaranteed. Since display performance is evaluated at 25°C, another temperature range should be confirmed.
- 2) Temp. = -30°C < 48h , Temp. = 80°C < 168h
Store LCD at normal temperature/humidity. Keep them free from vibration and shock.
An LCD that is kept at a low or a high temperature for a long time can be defective due to other conditions, even if the low or high temperature satisfies the standard.
(Please refer to “Precautions for Use” for details.)

- 3) Non-condensing

- 4) Temp. ≤ 40°C, 85%RH Max.

Temp. > 40°C, Absolute humidity shall be less than 85%RH at 40°C.

- 5)

Frequency	10 ~ 55 Hz	Acceleration value (0.3 ~ 9 m/s ²)
Vibration width	0.15mm	
Interval	10-55-10 Hz	1 minutes

2 hours in each direction X, Y, Z (6 hours total)

EIAJ ED-2531

- 6) Acceleration: 490 m/s², Pulse width: 11 ms

3 times in each direction: ±X, ±Y, ±Z

EIAJ ED-2531

5. Electrical characteristics

5-1. LCD

Temp. = -30 ~ 80°C

Item	Symbol	Condition	Min.	Typ.	Max.	Unit
Supply voltage 1)	V_{DD}	-	(3.0)	(3.3)	(3.6)	V
Current consumption	I_{DD}	2)	-	(TBD)	(TBD)	mA
Permissive input ripple voltage	V_{RP}	$V_{DD}=3.3V$	-	-	(100)	mVp-p
Input signal voltage 3)	V_{IL}	"Low" level	(0)	-	($0.3V_{DD}$)	V
	V_{IH}	"High" level	($0.7V_{DD}$)	-	(V_{DD})	V
Input reek current	I_{OL}	$V_{I3}=0V$	(-10)	-	(10)	μA
	I_{OH}	$V_{I3}=3.3V$	-	-	(400)	μA
LVDS Input voltage 4)	V_L	-	(0)	-	(1.9)	V
Differential input voltage	V_{ID}	-	(200)	-	(600)	mV
Differential input threshold voltage 4) 5)	V_{TL}	"Low" level	$V_{CM}-100$	-	-	mV
	V_{TH}	"High" level	-	-	$V_{CM}+100$	mV
Terminator	R_1	-	-	(100)	-	Ω
V_{DD} -turn-on conditions 1) 6)	t_1	-	-	-	(20)	ms
	t_2	-	(10)	-	-	ms
	t_3	-	(0)	-	-	ms
	t_4	-	(2)	-	-	s
	t_5	-	(200)	-	-	ms
	t_6	-	(200)	-	-	ms

1) V_{DD} -turn-on conditions

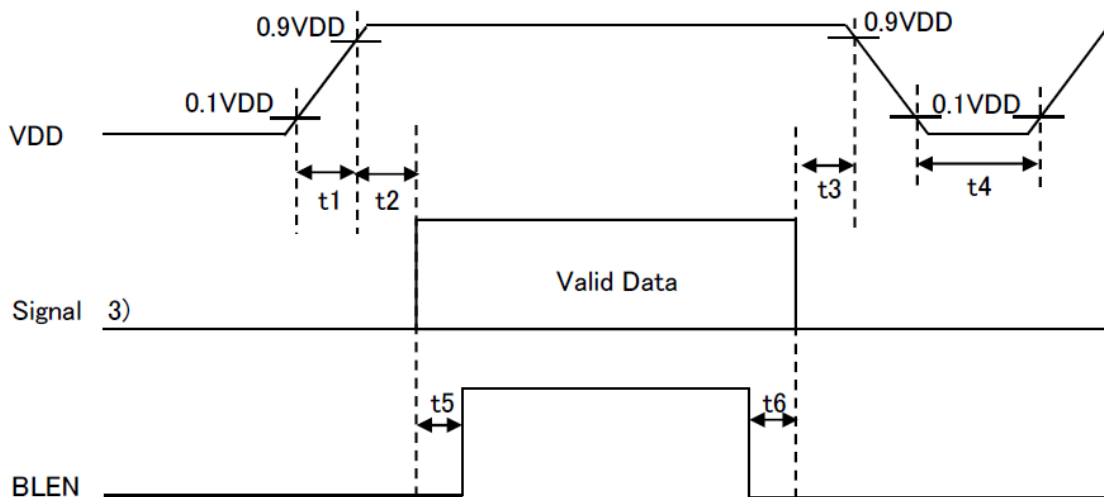

2) Display pattern:

$V_{DD} = 3.3V$, Temp. = 25°C

123 456 • • • • • 30703071 3072(dot)
 1
 2
 3
 :
 :
 :
 :
 :
 767
 768
 (dot)

TBD

3) Input signal : MODE, SC

4) Input signal : RxIN3+, RxIN3-, RxIN2+, RxIN2-, RxIN1+, RxIN1-, RxIN0+, RxIN0-
 CK IN+, CK IN-

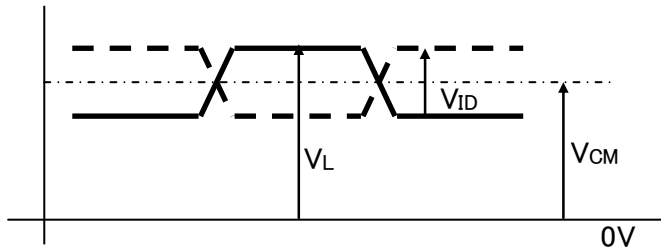

5) V_{CM} : LVDS Common mode voltage ($V_{CM}=1.25V$)

6) Please power on LVDS transmitter at the same time as VDD, or LVDS transmitter should be powered on first.

5-2. Constant current circuit for LED Backlight

Temp. = -30 ~ 80°C

Item	Symbol	Condition	Min.	Typ.	Max.	Unit
Supply voltage 1)	V_{IN}	-	(10.8)	(12.0)	(13.2)	V
Current consumption	I_{IN}	2)	-	(TBD)	(TBD)	mA
Permissive input ripple voltage	V_{RP_BL}	$V_{IN}=12.0V$	-	-	(100)	mVp-p
BLBRT Input signal voltage	V_{IL_BLBRT}	"Low" level	(0)	-	(0.8)	V
	V_{IH_BLBRT}	"High" level	(2.3)	-	(V_{IN})	V
BLBRT Input pull-down resistance	R_{IN_BLBRT}	-	(100)	(300)	(500)	kΩ
BLEN Input signal voltage	V_{IL_BLEN}	"Low" level	(0)	-	(0.8)	V
	V_{IH_BLEN}	"High" level	(2.3)	-	(V_{IN})	V
BLEN Input pull-down resistance	R_{IN_BLEN}	-	(100)	(300)	(500)	kΩ
P W M Frequency 3)	f_{PWM}	-	(TBD)	-	(TBD)	Hz
P W M Duty ratio 3)	D_{PWM}	$f_{PWM}=(TBD)$ Hz	(TBD)	-	(TBD)	%
			(TBD)	-	(TBD)	%
			(TBD)	-	(TBD)	%
Operating life time 4), 5)	T	Temp.=25°C	-	(50,000)	-	h

1) V_{IN} -turn-on conditions

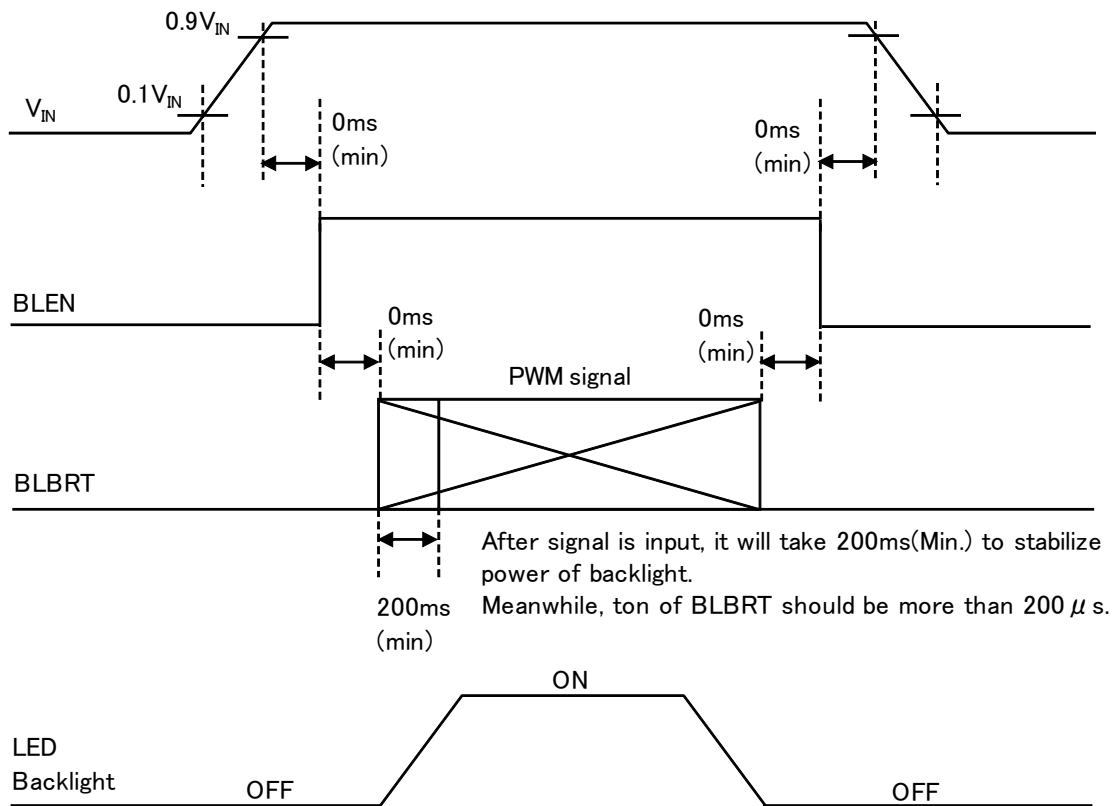

2) $V_{IN} = 12V$, Temp. = 25°C , $D_{PWM} = 100\%$

3) P W M Timing Diagram

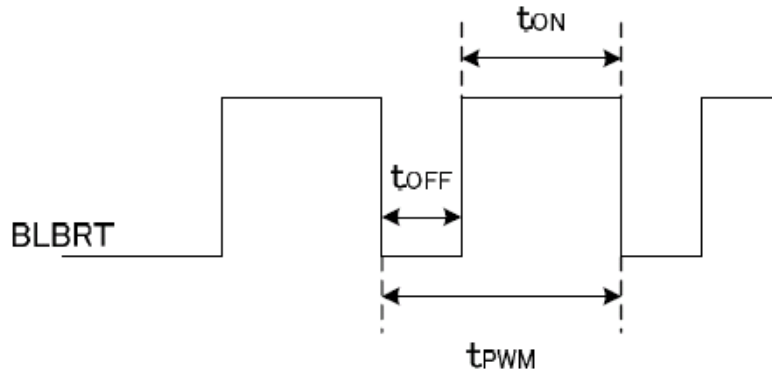

$t_{ON} , t_{OFF} \geq 50\mu s.$

In case of lower frequency, the deterioration of the display quality, flicker etc., may occur.

- 4) When brightness decrease 50% of minimum brightness.
The average life of a LED will decrease when the LCD is operating at higher temperatures.
- 5) Life time is estimated data.(Condition : $I_F=(TBD)mA, T_a=25^\circ C$ in chamber).

5-3. Touch panel

Item	Specification
Supply voltage for touch panel	5.0V
Terminal resistance	xL ~ xR : 274~640Ω
	yU ~ yL : 183~428Ω
Linearity	less than $\pm 2.0\%$
Insulation resistance	100MΩ or more at DC25V

6. Optical characteristics

Measuring spot = ϕ 6.0mm, Temp. = 25°C

Item	Symbol	Condition	Min.	Typ.	Max.	Unit	
Response time	Rise	τ_r	$\theta = \phi = 0^\circ$	-	(18)	-	ms
	Down	τ_d	$\theta = \phi = 0^\circ$	-	(12)	-	ms
Viewing angle range View direction	θ_{UPPER}	CR \geq 10	-	(85)	-	deg.	
	θ_{LOWER}		-	(85)	-		
	ϕ_{LEFT}		-	(85)	-	deg.	
	ϕ_{RIGHT}		-	(85)	-		
Contrast ratio	CR	$\theta = \phi = 0^\circ$	(525)	(750)	-	-	
Brightness	L	IF=(TBD)mA/Line	(220)	(320)	-	cd/m ²	
Chromaticity coordinates	Red	x	$\theta = \phi = 0^\circ$	(0.540)	(0.590)	(0.640)	-
		y		(0.305)	(0.355)	(0.405)	
	Green	x	$\theta = \phi = 0^\circ$	(0.275)	(0.325)	(0.375)	
		y		(0.535)	(0.585)	(0.635)	
	Blue	x	$\theta = \phi = 0^\circ$	(0.105)	(0.155)	(0.205)	
		y		(0.075)	(0.125)	(0.175)	
	White	x	$\theta = \phi = 0^\circ$	(0.250)	(0.300)	(0.350)	
		y		(0.280)	(0.330)	(0.380)	

6-1. Definition of contrast ratio

$$CR(\text{Contrast ratio}) = \frac{\text{Brightness with all pixels "White"}}{\text{Brightness with all pixels "Black"}}$$

6-2. Definition of response time

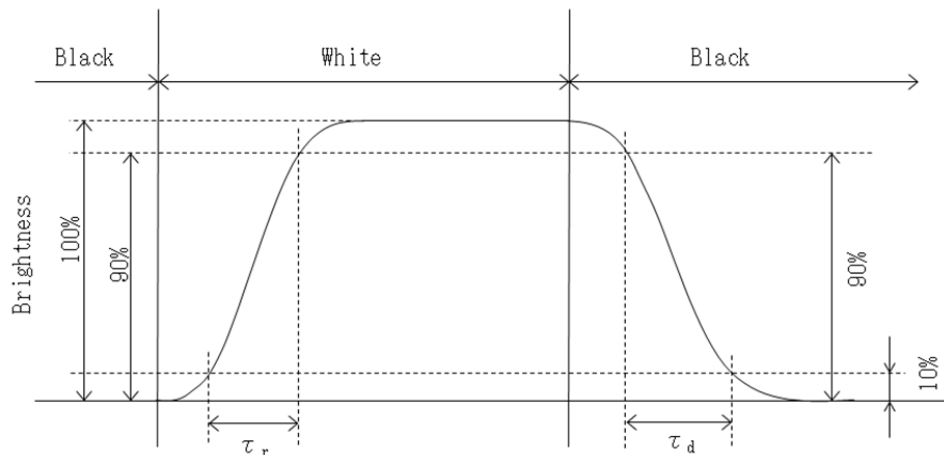

6-3. Definition of viewing angle

【FPC side】

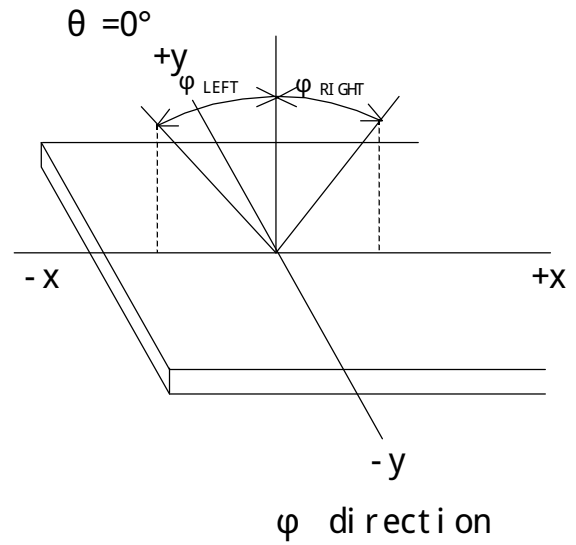
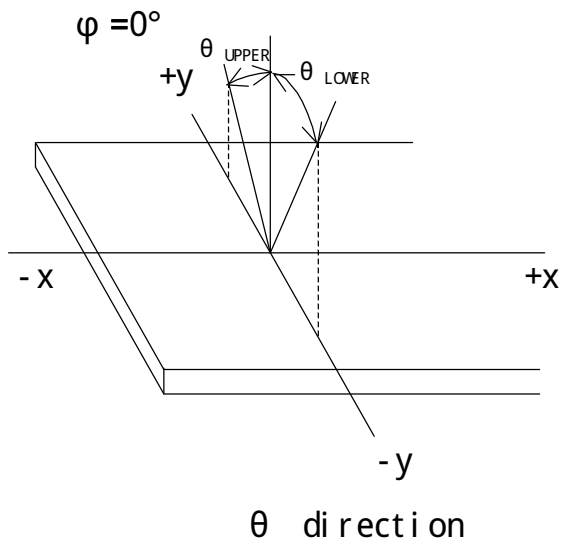

6-4. Brightness measuring points

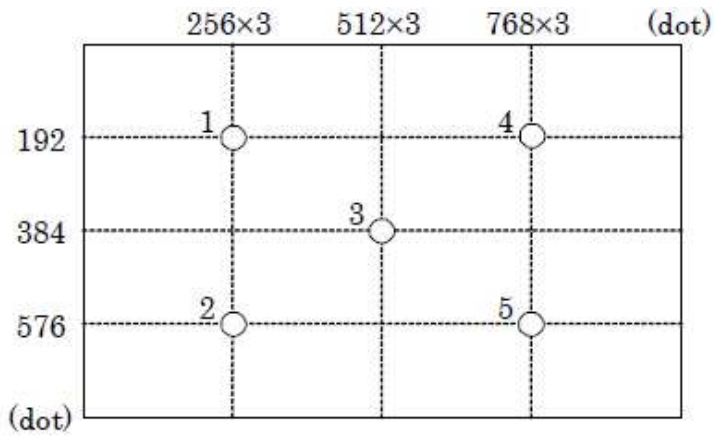

- 1) Rating is defined as the white brightness at center of display screen(3).
- 2) 5 minutes after LED is turned on. (Ambient Temp.=25°C)

7. Interface signals

7-1. Interface signals

No.	Symbol	Description	Note
1	V _{DD}	+3.3V power supply	
2	V _{DD}	+3.3V power supply	
3	GND	GND	
4	GND	GND	
5	RxIN0-	LVDS receiver signal CH0(-)	LVDS
6	RxIN0+	LVDS receiver signal CH0(+)	LVDS
7	GND	GND	
8	RxIN1-	LVDS receiver signal CH1(-)	LVDS
9	RxIN1+	LVDS receiver signal CH1(+)	LVDS
10	GND	GND	
11	RxIN2-	LVDS receiver signal CH2(-)	LVDS
12	RxIN2+	LVDS receiver signal CH2(+)	LVDS
13	GND	GND	
14	CK IN1-	LVDS receiver signal CK(-)	LVDS
15	CK IN1+	LVDS receiver signal CK(+)	LVDS
16	GND	GND	
17	RxIN3-	LVDS receiver signal CH3(-)	LVDS
18	RxIN3+	LVDS receiver signal CH3(+)	LVDS
19	MODE	Bit data select signal(GND: 6bit mode, High: 8bit mode)	
20	SC	Scan direction control(GND: Normal, High: Reverse)	1)

LCD connector : 20186-020E-11F (I-PEX)
 Matching connector : 20197-020U-F (I-PEX)
 : 20197-T20U-F (I-PEX)

LVDS receiver : Embedded in ASIC
 Matching LVDS transmitter : THC63LVDM83R(THine Electronics) or compatible

1) Scanning

SC : GND

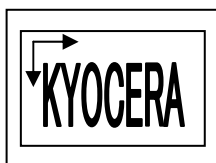

SC : High

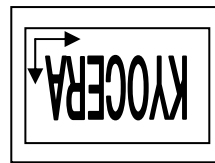

7-2. LED

No.	Symbol	Description	Note
1	V _{IN}	+12V power supply	
2	V _{IN}	+12V power supply	
3	BLBRT	PWM signal(Brightness adjustment)	
4	BLEN	ON/OFF terminal voltage	
5	GND	GND	
6	GND	GND	

LCD connector : SM06B-SHLS-G-TF(LF)(SN) (JST)
 Matching connector : SHLP-06V-S-B (JST)

7-3. Data mapping(6bit input)

1) Location of MODE (THC63LVDM83R(THine Electronics) or compatible)

Transmitter		MODE
Pin No.	Data	= L(GND)
51	TA0	R0(LSB)
52	TA1	R1
54	TA2	R2
55	TA3	R3
56	TA4	R4
3	TA5	R5(MSB)
4	TA6	G0(LSB)
6	TB0	G1
7	TB1	G2
11	TB2	G3
12	TB3	G4
14	TB4	G5(MSB)
15	TB5	B0(LSB)
19	TB6	B1
20	TC0	B2
22	TC1	B3
23	TC2	B4
24	TC3	B5(MSB)
27	TC4	(HS)
28	TC5	(VS)
30	TC6	DE
50	TD0	GND
2	TD1	GND
8	TD2	GND
10	TD3	GND
16	TD4	GND
18	TD5	GND
25	TD6	(NA)

MODE=L(GND)

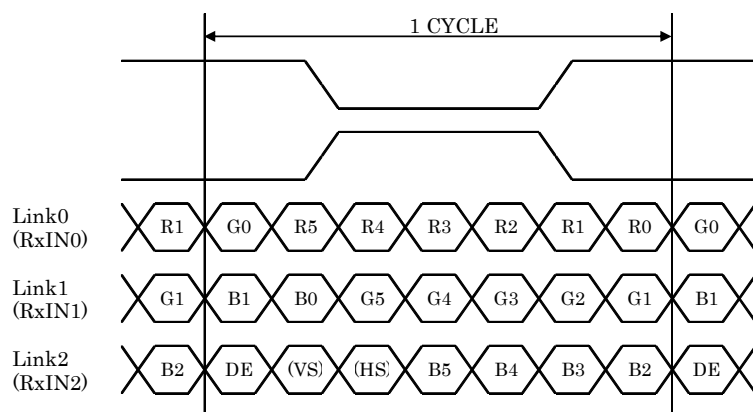

DE : DATA ENABLE
 HS : H_{SYNC}
 VS : V_{SYNC}

2) Block Diagram

MODE=L(GND)

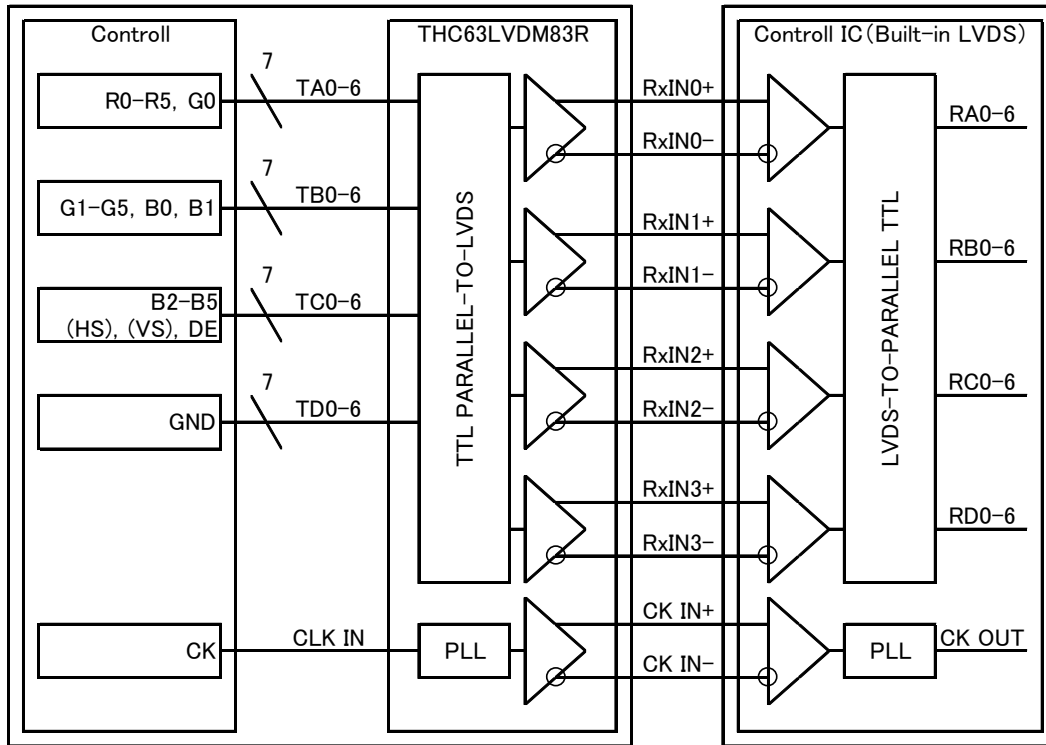

When using " 6-bit Transmitter" , please connect the unused channel of the control IC receiver as described in the diagram below.

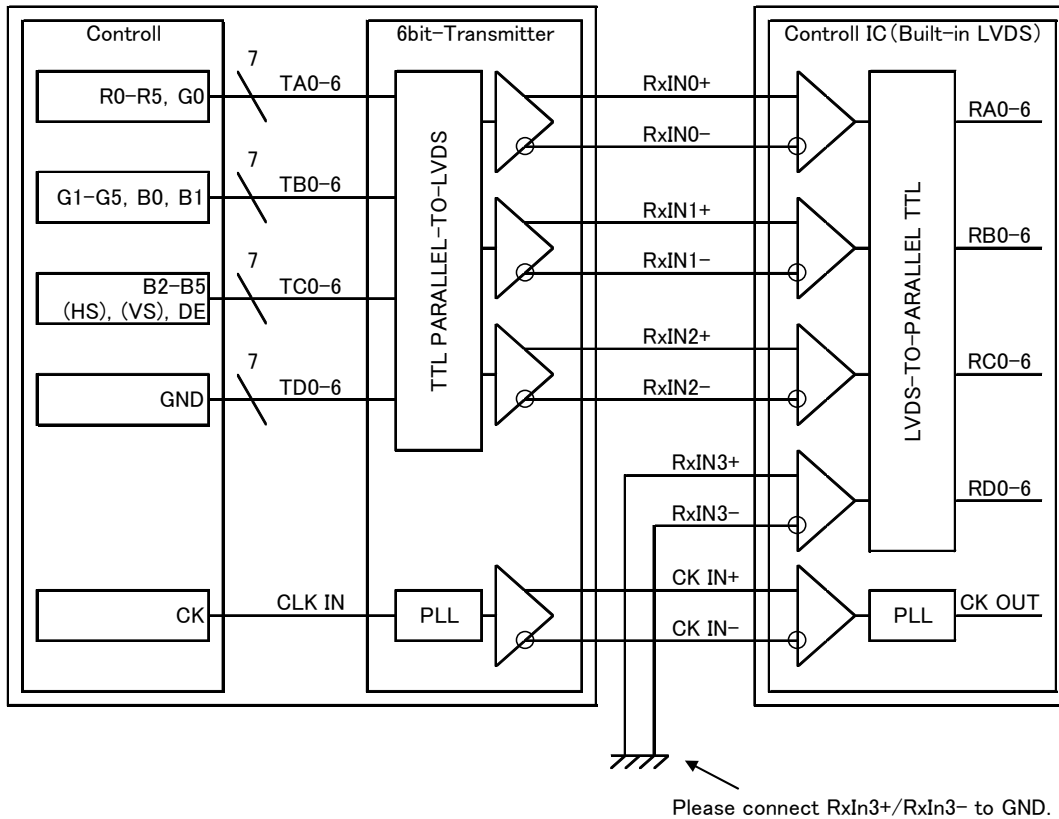

7-4. Data mapping(8bit input)

1) Location of MODE (THC63LVDM83R(THine Electronics) or compatible)

Transmitter		MODE
Pin No.	Data	= H(3.3V)
51	TA0	R0(LSB)
52	TA1	R1
54	TA2	R2
55	TA3	R3
56	TA4	R4
3	TA5	R5
4	TA6	G0(LSB)
6	TB0	G1
7	TB1	G2
11	TB2	G3
12	TB3	G4
14	TB4	G5
15	TB5	B0(LSB)
19	TB6	B1
20	TC0	B2
22	TC1	B3
23	TC2	B4
24	TC3	B5
27	TC4	(HS)
28	TC5	(VS)
30	TC6	DE
50	TD0	R6
2	TD1	R7(MSB)
8	TD2	G6
10	TD3	G7(MSB)
16	TD4	B6
18	TD5	B7(MSB)
25	TD6	(NA)

MODE= H(3.3V)

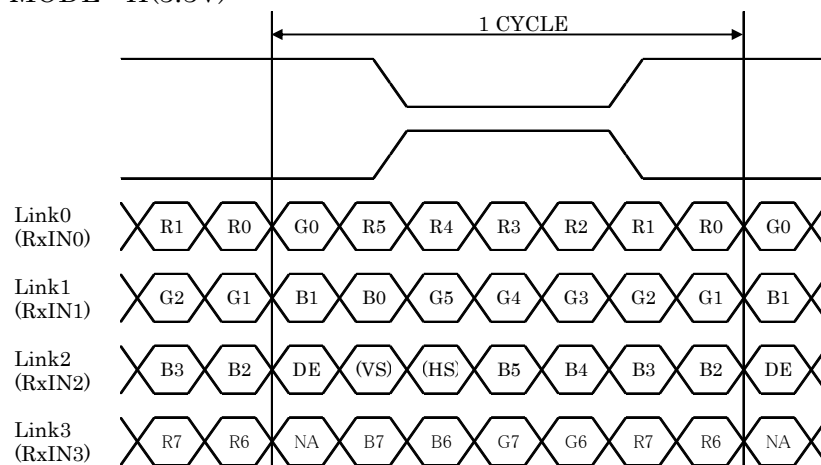

DE : DATA ENABLE

HS : H_{SYNC}

VS : V_{SYNC}

2) Block Diagram

MODE= H(3.3V)

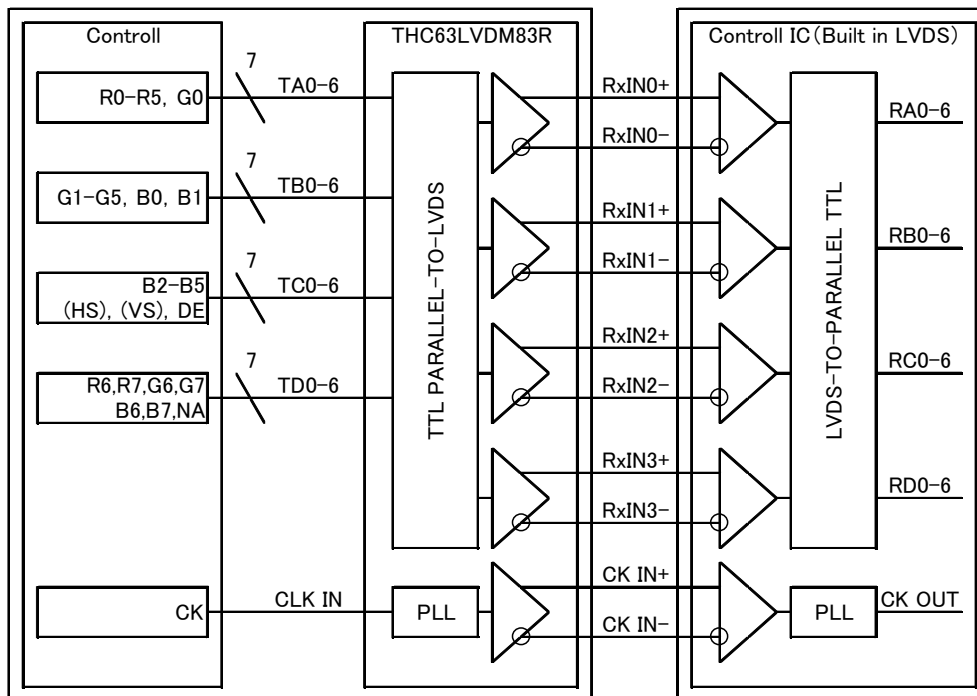

7-5. Touch panel

No.	Symbol	Description
1	xL	x-Left terminal
2	yU	y-Upper terminal
3	xR	x-Right terminal
4	yL	y-Lower terminal

Touch panel side connector : 1mm pitch
 Recommended matching connector : Series 9616 (IRISO)
 : Series 9610 (IRISO)
 : Series FMS (JST)

8. Input timing characteristics

8-1. Timing characteristics

Item		Symbol	Min.	Typ.	Max.	Unit	Note
Clock (CK)	Frequency	1/Tc	(52)	(65)	(TBD)	MHz	
Enable signal (DE)	Horizontal Period	Th	1,114	1,344	1,400	Dot	
			(TBD)	(20.7)	-	μ s	1)
	Horizontal display period	Thd	1,024			Tc	
	Vertical Period	Tv	(778)	(806)	(845)	Line	
	Vertical display period	Tvd	768			Th	
Refresh rate		fv	(50)	(60)	(TBD)	Hz	2)

- 1) Please set a clock frequency, a vertical dormant period, and the horizontal dormant period so that the Horizontal Period should not reach less than Min. value.
- 2) If the refresh rate reach less than Min. value, the deterioration of the display quality, flicker etc., may occur.($fv=1/Tv$)

Vertical Timing Diagram

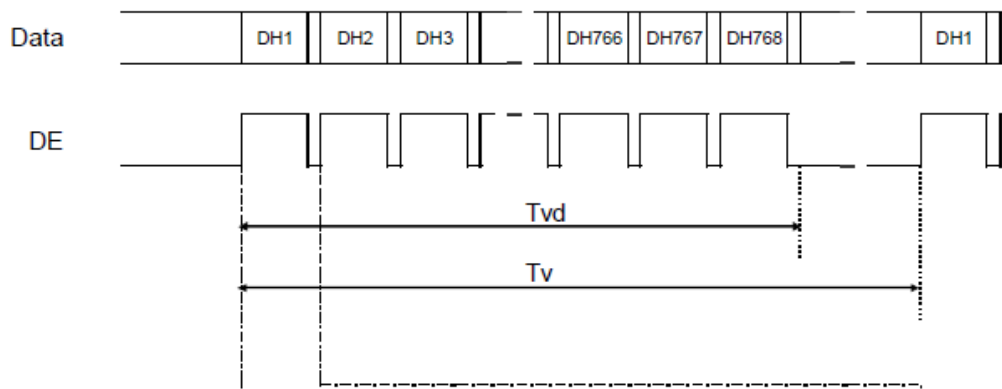

Horizontal Timing Diagram

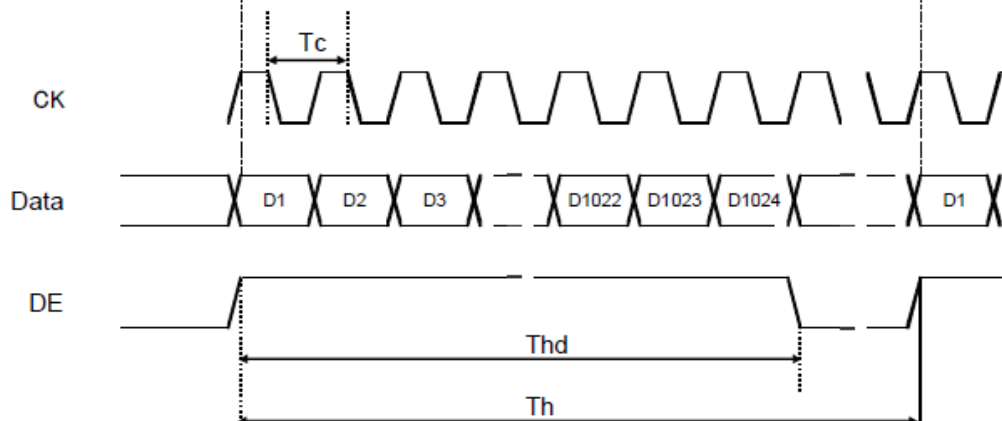

8-2. Input Data Signals and Display position on the screen

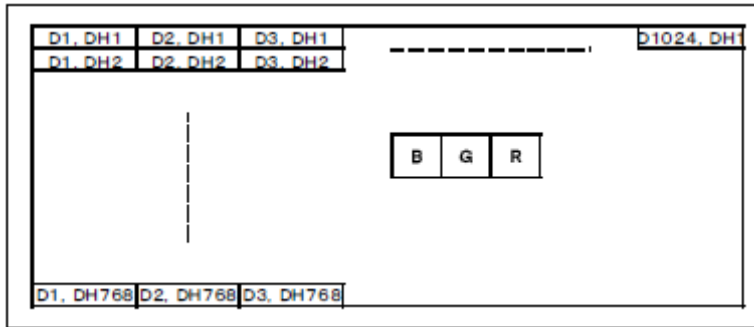

9. Design guidance for analog touch panel

9-1. Electrical (In customer's design, please remember the following considerations.)

- 1) Do not use the current regulated circuit.
- 2) Keep the current limit with top and bottom layer. (Please refer to “Electrical absolute maximum ratings” for details.)
- 3) Analog touch panel can not sense two points touching separately.
- 4) A contact resistance is appeared at the touch point between top and bottom layer. After this resistance has stable read of the touch panel position data.
- 5) Because noise of inverter or peripheral circuits may interfere signal of touch panel itself it is necessary to design carefully in advance to avoid these noise problem.

9-2. Software

- 1) Do the "User Calibration".
- 2) "User Calibration" may be needed with long term using. Include "User Calibration" menu in your software.
- 3) When drawing a line with a stylus, there may be a slight discontinuity when the stylus passes over a spacer-dot. If necessary, please provide a compensation feature within your software.

9-3. Mounting on display and housing bezel

- 1) Do not use an adhesive tape to bond it on the front of touch panel and hang it to the housing bezel.
- 2) Never expand the touch panel top layer (PET-film) like a balloon by internal air pressure. The life of the touch panel will be extremely short.
- 3) If a dew will be on the heat-sealed area or exposed traces at the end of a flexible tail, the migration of silver can occur. This will cause sometimes a short circuit.
- 4) Must maintain a gap between inside of bezel and touch panel to avoid malfunction or electrode damage of touch panel.

10. Lot number identification

The lot number shall be indicated on the back of the backlight case of each LCD.

TCG121XGLP*PFA-AA*39 - □□ - □□ - □ MADE IN □□□□□
 ↓↓ ↓ ↓ ↓ ↓
 1 2 3 4 5

No1. - No5. above indicate
 1. Year code
 2. Month code
 3. Date
 4. Version Number
 5. Country of origin (Japan or China)

Year	2013	2014	2015	2016	2017	2018
Code	3	4	5	6	7	8

Month	Jan.	Feb.	Mar.	Apr.	May	Jun.
Code	1	2	3	4	5	6

Month	Jul.	Aug.	Sep.	Oct.	Nov.	Dec.
Code	7	8	9	X	Y	Z

11. Warranty

11-1. Incoming inspection

Please inspect the LCD within one month after your receipt.

11-2. Production warranty

Kyocera warrants its LCD's for a period of 12 months from the ship date. Kyocera shall, by mutual agreement, replace or re-work defective LCD's that are shown to be Kyocera's responsibility.

12. Precautions for use

12-1. Installation of the LCD

- 1) The LCD shall be installed so that there is no pressure on the LSI chips.
- 2) Since this product is wide viewing product, occurrence level of in-plane unevenness by the external stress is different compared to current normal viewing product. So there is a possibility that in-plane unevenness will be occurred by over twist, strain giving by attaching to LCD, and over pressure to touch panel. Please be careful of stress when designing the housing.

12-2. Static electricity

- 1) Since CMOS ICs are mounted directly onto the LCD glass, protection from static electricity is required.
- 2) Workers should use body grounding. Operator should wear ground straps.

12-3. LCD operation

- 1) The LCD shall be operated within the limits specified. Operation at values outside of these limits may shorten life, and/or harm display images.
- 2) Please select the best display pattern based on your evaluation because flicker, lines or nonuniformity or unevenness can be visible depending on display patterns.

12-4. Storage

- 1) The LCD shall be stored within the temperature and humidity limits specified.
Store in a dark area, and protect the LCD from direct sunlight or fluorescent light.
- 2) Always store the LCD so that it is free from external pressure onto it.

12-5. Usage

- 1) **DO NOT** store in a high humidity environment for extended periods. Polarizer degradation bubbles, and/or peeling off of the polarizer may result.
- 2) Do not push or rub the touch panel's surface with hard to sharp objects such as knives, or the touch panel may be scratched.
- 3) When the touch panel is dirty, gently wipe the surface with a soft cloth, sometimes moistened by mild detergent or alcohol. If a hazardous chemical is dropped on the touch panel by mistake, wipe it off right away to prevent human contact.
- 4) The touch panel is made of glass. It may break when dropped, or vibrated excessively. Usually there is a film on the surface of the glass which would prevent broken glass from scattering, but nevertheless handle it carefully during assembly and treat it gently during use.
- 5) Always keep the LCD free from condensation during testing. Condensation may permanently spot or stain the polarizer.
- 6) Do not disassemble LCD because it will result in damage.
- 7) This Kyocera LCD has been specifically designed for use in general electronic devices, but not for use in a special environment such as usage in an active gas. Hence, when the LCD is supposed to be used in a special environment, evaluate the LCD thoroughly beforehand and do not expose the LCD to chemicals such as an active gas.
- 8) Please do not use solid-base image pattern for long hours because a temporary afterimage may appear. We recommend using screen saver etc. in cases where a solid-base image pattern must be used.
- 9) Liquid crystal may leak when the LCD is broken. Be careful not to let the fluid go into your eyes and mouth. In the case the fluid touches your body; rinse it off right away with water and soap.

13. Reliability test data

Test item	Test condition	Test time	Judgement
High temp. atmosphere	80°C	240h	Display function : TBD Display quality : TBD Current consumption : TBD
Low temp. atmosphere	-30°C	240h	Display function : TBD Display quality : TBD Current consumption : TBD
High temp. humidity atmosphere	40°C 90% RH	240h	Display function : TBD Display quality : TBD Current consumption : TBD
Temp. cycle	-30°C 0.5h R.T. 0.5h 80°C 0.5h	10cycles	Display function : TBD Display quality : TBD Current consumption : TBD
High temp. operation	70°C	500h	Display function : TBD Display quality : TBD Current consumption : TBD
Point Activation life	Silicon rubber, Tip : R = 4.0 Hitting force 3N Hitting speed 2 time/s	one million times	Terminal resistance : TBD Insulation resistance : TBD Linearity : TBD Actuation Force : TBD

- 1) Each test item uses a test LCD only once. The tested LCD is not used in any other tests.
- 2) The LCD is tested in circumstances in which there is no condensation.
- 3) The reliability test is not an out-going inspection.
- 4) The result of the reliability test is for your reference purpose only.
The reliability test is conducted only to examine the LCD's capability.

TENTATIVE

It is possible to change some dimensions.
(本図記載の形状・及び寸法値は変更の可能性があります)

No	Description	Drawn	Checked	Checked	Approved

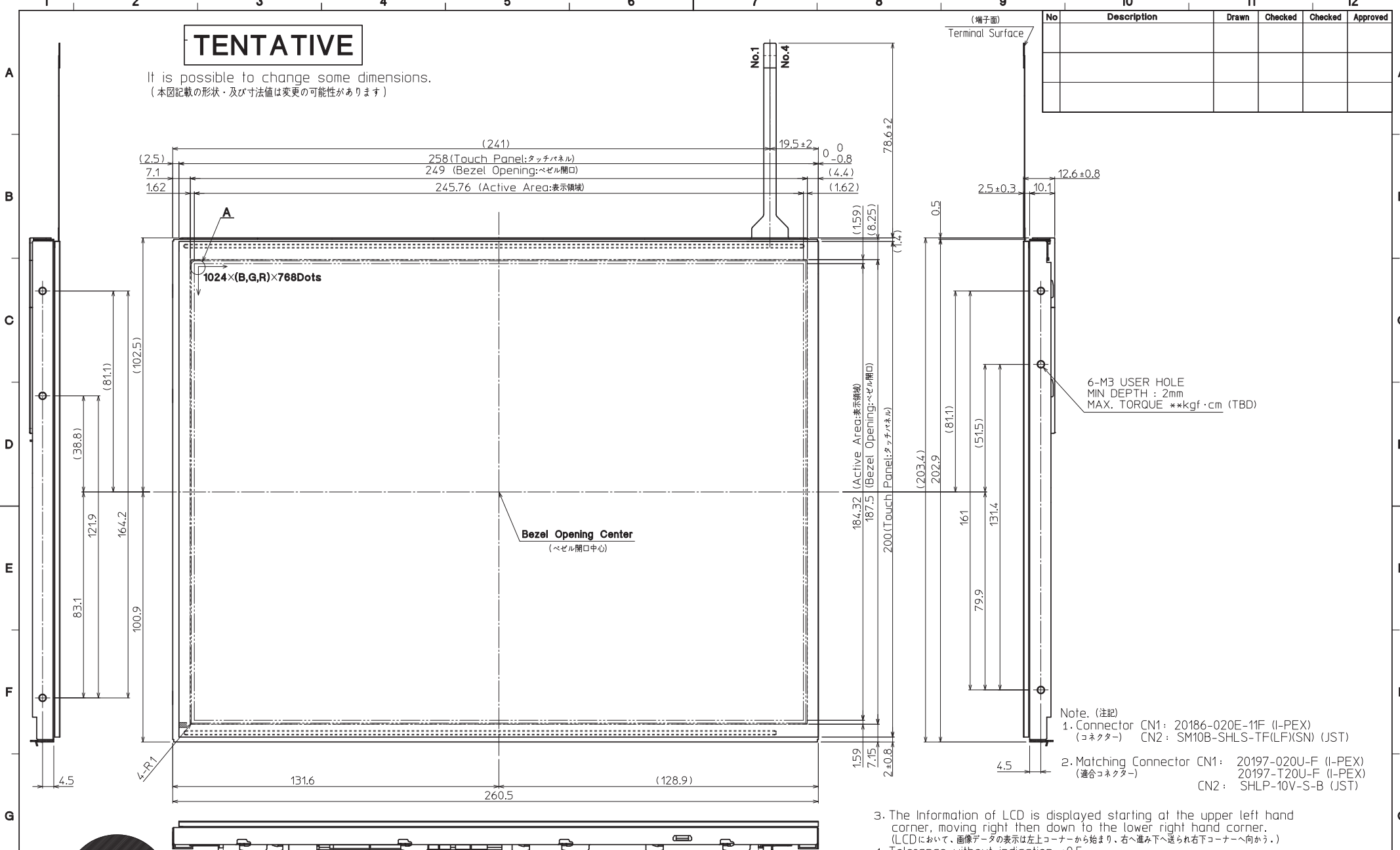

1024×(B,G,R)×768Dots

Bezel Opening Center
(ベゼル開口中心)

6-M3 USER HOLE
MIN DEPTH : 2mm
MAX. TORQUE **kgf·cm (TBD)

- Note. (注記)
- Connector CN1: 20186-020E-11F (I-PEX)
(コネクタ) CN2: SM10B-SHLS-TF(LF)(SN) (JST)
 - Matching Connector CN1: 20197-020U-F (I-PEX)
(適合コネクタ) CN2: SHLP-10V-S-B (JST)

- The Information of LCD is displayed starting at the upper left hand corner, moving right then down to the lower right hand corner.
(LCDにおいて、画像データの表示は左上コーナーから始まり、右へ進み下へ送られ右下コーナーへ向かう。)
- Tolerance without indication: ±0.5
(指示無き公差)
- There is a possibility that in-plane unevenness will be occurred by over twist, stress giving by attaching to LCD, and over pressure to touch panel. Please be careful of stress when designing the housing.
(過度な捻じり(ひずみ)、LCD固定時での応力発生、タッチパネルでの過度な押し圧によっては、パネル面内にムラが発生することがありますので、筐体設計において、事前に十分確認願います。)
- Touch Panel P/N : P2012000 (121A8041500-1)



DETAIL A (Dot Size)
(NTS)

Material 材質	Treatment 処理	Approved '12.10.01	Checked	Checked '12.10.01	Drawn Rahadian	Scale 1:1 (NTS)	Title TCG121XGLP*PFA		Year-Month-Day '12.09.25	Size 2
Quantity 製作数	Description; 備考	RoHS	朝倉	今村		Outline Dimensions	Drawing No. 12446-10276		1/2	

A
B
C
D
E
F
G
H
I
J
K
L

Note (注記)

No	Name(名称)	Explanation(説明)
1	T.P.	Touch panel (タッチパネル)
2	T.P. Active Area (T.P.アクティブエリア)	Operating area of touch panel (タッチパネルの動作範囲)
3	T.P. Viewing Area (T.P.ビューイングエリア)	Warranty area of touch panel's appearance (タッチパネルの外観(傷・異物等)保証範囲)

By giving pressure between the active area and the viewing area of the touch panel, there is a possibility that the touch panel will operate.
(タッチパネルアクティブエリアとタッチパネルビューイングエリア間は荷重をかけた場合は、タッチパネルが動作する可能性があります。)

No	Description	Drawn	Checked	Checked	Approved

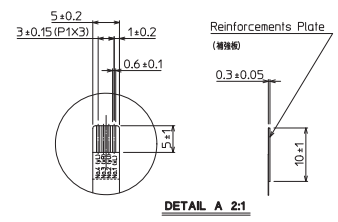
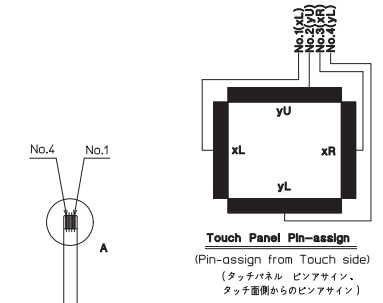
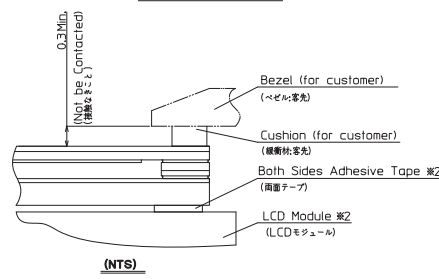
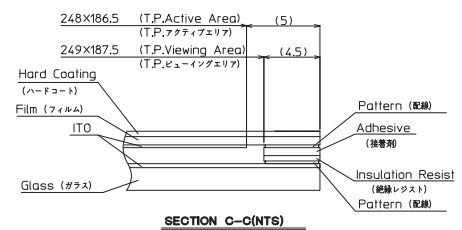
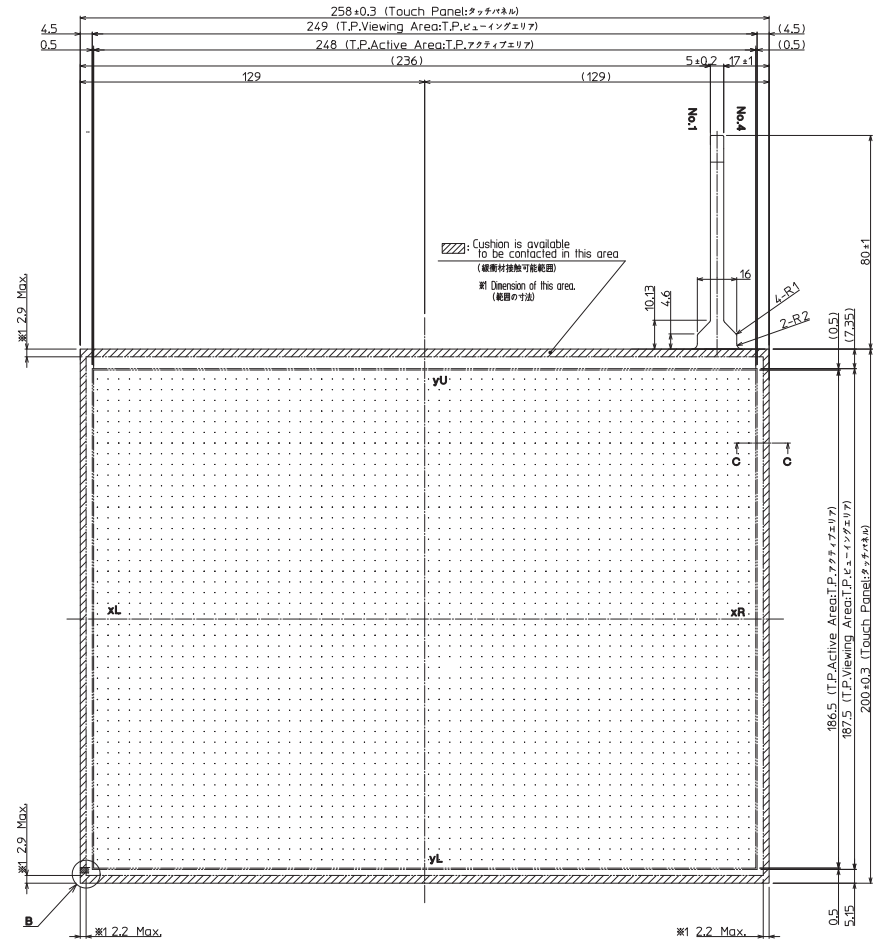
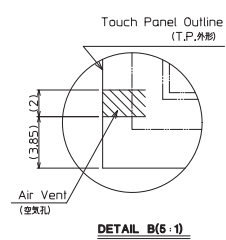

Precaution in use of touch panel.
(タッチパネル使用上の注意事項)

※2 In case of assemble to the LCD.
(LCDに取り付ける場合)

1. Fix touch panel at LCD module and the rear side of touch panel.
(タッチパネルの固定はLCDモジュール側とタッチパネル裏面とで行なうこと。)

2. Must maintain a gap between inside of bezel and touch panel to avoid malfunction or electrode damage of touch panel.
(ベゼル内側とタッチパネルの接触厳禁。誤動作や電極破損の原因となります。)

3. Tolerance without indication: ±0.5
(指示無き公差)

Precaution in use of touch panel.
(タッチパネル使用上の注意事項)

There is vent channel to equalize air pressure between the inner space of the touch panel and the atmosphere.

Please make sure it is not blocked by your housing and mounting method.
(タッチパネルの中には内圧と外圧を均一にするための通気孔を設けています。取り付け時この通気孔を塞がないようにしてください。)

Material	Treatment	Approved	Checked	Checked	Drawn	Scale	Title	Year-Month-Day	Size
数量 Quantity 製作数	処理 Description 備考	11.01.17 東郷		11.01.17 今村	固福	1/8(1:2/NTS)	P2012000 T.P. Outline Dimensions	11.01.14	1

RoHS

Scale: 1/8(1:2/NTS)

Title: P2012000 T.P. Outline Dimensions

Year-Month-Day: 11.01.14

Size: 1

Drawing No.: 121A8041500

1 2 3 4 5 6 7 8 9 10 11 12 13 14 15 16

Spec No.	TQ3C-8EAF0-E2YAL05-00
Date	January 12, 2013

KYOCERA INSPECTION STANDARD

TYPE : TCG121XGLP*PFA-AA*39

KYOCERA CORPORATION
LCD DIVISION

Original Issue Date	Designed by : Engineering dept.			Confirmed by : QA dept.	
	Prepared	Checked	Approved	Checked	Approved
January 12, 2013	<i>K. Mori</i>	<i>Y. Yamazaki</i>	<i>M. Fujitani</i>	<i>I. Hamada</i>	<i>T. Ito</i>