



Chipsmall Limited consists of a professional team with an average of over 10 year of expertise in the distribution of electronic components. Based in Hongkong, we have already established firm and mutual-benefit business relationships with customers from,Europe,America and south Asia,supplying obsolete and hard-to-find components to meet their specific needs.

With the principle of “Quality Parts,Customers Priority,Honest Operation,and Considerate Service”,our business mainly focus on the distribution of electronic components. Line cards we deal with include Microchip,ALPS,ROHM,Xilinx,Pulse,ON,Everlight and Freescale. Main products comprise IC,Modules,Potentiometer,IC Socket,Relay,Connector.Our parts cover such applications as commercial,industrial, and automotives areas.

We are looking forward to setting up business relationship with you and hope to provide you with the best service and solution. Let us make a better world for our industry!



Contact us

Tel: +86-755-8981 8866 Fax: +86-755-8427 6832

Email & Skype: info@chipsmall.com Web: www.chipsmall.com

Address: A1208, Overseas Decoration Building, #122 Zhenhua RD., Futian, Shenzhen, China



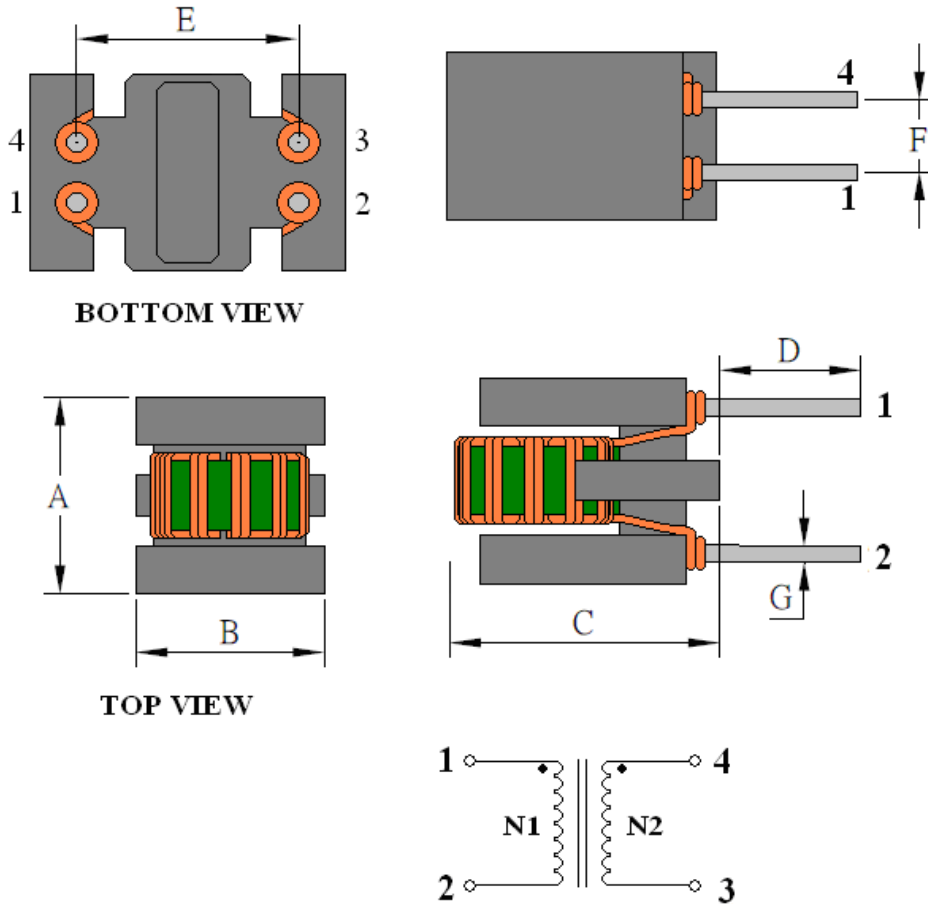

Dimensions

A	B	C	D	E	F	G
7.5 Max.	8.5 Max.	10.5 Max.	3.5±1.0	5.08±0.5	2.54±0.3	0.6±0.1

all dimension in mm

SPECIFICATIONS

Inductance	52µH±25%
	Test Condition : 10kHz/50mV Measurement Instrument : HP 4263B LCR Meter
Impedance	DCR(Max.) : 15mΩ
	Measurement Instrument : HIOKI 3540 mΩ Hitester
Rated Current	I _{DC} (Typ.) : 3.14A
	Measurement Instrument : Agilent 34401A Meter
Rated voltage	500VDC
Operating temperature	-40C° ~ +105C°
Recommended Through Hole	Φ0.8mm

Specifications can be changed without notice! Make sure you are using the latest documentation, downloadable at www.tracopower.com