



Chipsmall Limited consists of a professional team with an average of over 10 year of expertise in the distribution of electronic components. Based in Hongkong, we have already established firm and mutual-benefit business relationships with customers from,Europe,America and south Asia,supplying obsolete and hard-to-find components to meet their specific needs.

With the principle of "Quality Parts,Customers Priority,Honest Operation,and Considerate Service",our business mainly focus on the distribution of electronic components. Line cards we deal with include Microchip,ALPS,ROHM,Xilinx,Pulse,ON,Everlight and Freescale. Main products comprise IC,Modules,Potentiometer,IC Socket,Relay,Connector.Our parts cover such applications as commercial,industrial, and automotives areas.

We are looking forward to setting up business relationship with you and hope to provide you with the best service and solution. Let us make a better world for our industry!



Contact us

Tel: +86-755-8981 8866 Fax: +86-755-8427 6832

Email & Skype: info@chipsmall.com Web: www.chipsmall.com

Address: A1208, Overseas Decoration Building, #122 Zhenhua RD., Futian, Shenzhen, China



Specification

40 - Gbps QSFP+ Pluggable

Optical Transceiver Module

40GBASE-LR4



Ordering Information

TCW-Q1LAA-FCQ

Model Name	Voltage	Category	Device type	Interface	Temperature	Distance
TCW-Q1LAA-FCQ	3.3V	With DDMI	CWDM DFB	CML/CML	0°C~+70°C	2~10km

Features

- Compliant with 40G Ethernet IEEE 802.3ae 40GBASE-LR4 standards
- QSFP+ MSA compliant
- Compliant with QDR/DDR Infiniband data rates
- Up to 11.2Gbps data rate per wavelength
- 4 CWDM lanes MUX/DEMUX design
- Up to 10km transmission
- Operating case temperature: 0~70C
- Maximum 3.5W operation power
- RoHS compliant

Applications

- 40GBASE-LR4 Ethernet links
- Infiniband QDR and DDR interconnects
- Client-side 40G Telecom connections

General Description

This product is a transceiver module designed for 2m-10km optical communication applications. The design is compliant to 40GBASE-LR4 of the IEEE P802.3ba standard. The module converts 4 inputs channels (ch) of 10Gb/s electrical data to 4 CWDM optical signals, and multiplexes them into a single channel for 40Gb/s optical transmission. Reversely, on the receiver side, the module optically de-multiplexes a 40Gb/s input into 4 CWDM channels signals, and converts them to 4 channel output electrical data.

The central wavelengths of the 4 CWDM channels are 1271, 1291, 1311 and 1331 nm as members of the CWDM wavelength grid defined in ITU-T G694.2. It contains a duplex LC connector for the optical interface and a 148-pin connector for the electrical interface. To minimize the optical dispersion in the long-haul system, single-mode fiber (SMF) has to be applied in this module.

The product is designed with form factor, optical/electrical connection and digital diagnostic interface according to the QSFP Multi-Source Agreement (MSA). It has been designed to meet the harshest external operating conditions including temperature, humidity and EMI interference.

Functional Description

This product converts the 4-channel 10Gb/s electrical input data into CWDM optical signals (light), by a driven 4-wavelength Distributed Feedback Laser (DFB) array. The light is combined by the MUX parts as a 40Gb/s data, propagating out of the transmitter module from the SMF. The receiver module accepts the 40Gb/s CWDM optical signals input, and de-multiplexes it into 4 individual 10Gb/s channels with different wavelength. Each wavelength light is collected by a discrete photo diode, and then outputted as electric data after amplified by a TIA. Figure 1 shows the functional block diagram of this product.

A single +3.3V power supply is required to power up this product. Both power supply pins VccTx and VccRx are internally connected and should be applied concurrently. As per MSA specifications the module offers 7 low speed hardware control pins (including the 2-wire serial interface): ModSelL, SCL, SDA, ResetL, LPMode, ModPrsL and IntL.

Module Select (ModSelL) is an input pin. When held low by the host, this product responds to 2-wire serial communication commands. The ModSelL allows the use of this product on a single 2-wire interface bus – individual ModSelL lines must be used.

Serial Clock (SCL) and Serial Data (SDA) are required for the 2-wire serial bus communication interface and enable the host to access the QSFP memory map.

The ResetL pin enables a complete reset, returning the settings to their default state, when a low level on the ResetL pin is held for longer than the minimum pulse length. During the execution of a reset the host shall disregard all status bits until it indicates a completion of the reset interrupt. The product indicates this by posting an IntL (Interrupt) signal with the Data_Not_Ready bit negated in the memory map. Note that on power up (including hot insertion) the module should post this completion of reset interrupt without requiring a reset.

Low Power Mode (LPMode) pin is used to set the maximum power consumption for the product in order to protect hosts that are not capable of cooling higher power modules, should such modules be accidentally inserted.

Module Present (ModPrsL) is a signal local to the host board which, in the absence of a product, is normally pulled up to the host Vcc. When the product is inserted into the connector, it completes the path to ground through a resistor on the host board and asserts the signal. ModPrsL then indicates its present by setting ModPrsL to a “Low” state.

Interrupt (IntL) is an output pin. “Low” indicates a possible operational fault or a status critical to the host system. The host identifies the source of the interrupt using the 2-wire serial interface. The IntL pin is an open collector output and must be pulled to the Host Vcc voltage on the Host board.

Transceiver Block Diagram

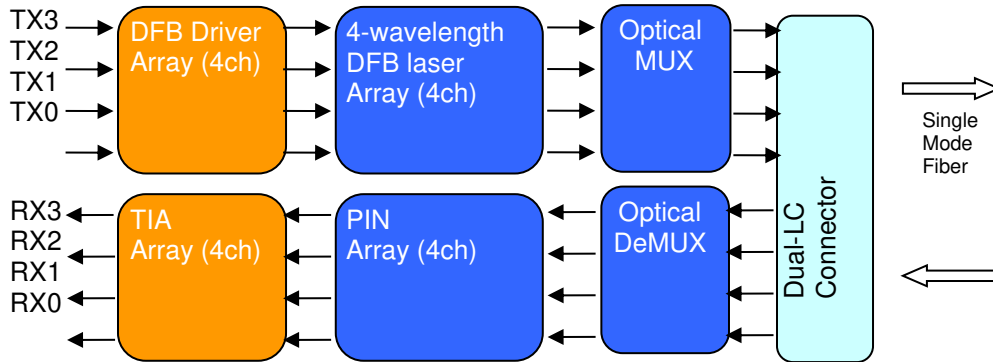

Figure 1: 40Gb/s QSFP LR4 Transceiver Block Diagram

Pin Assignment and Pin Description

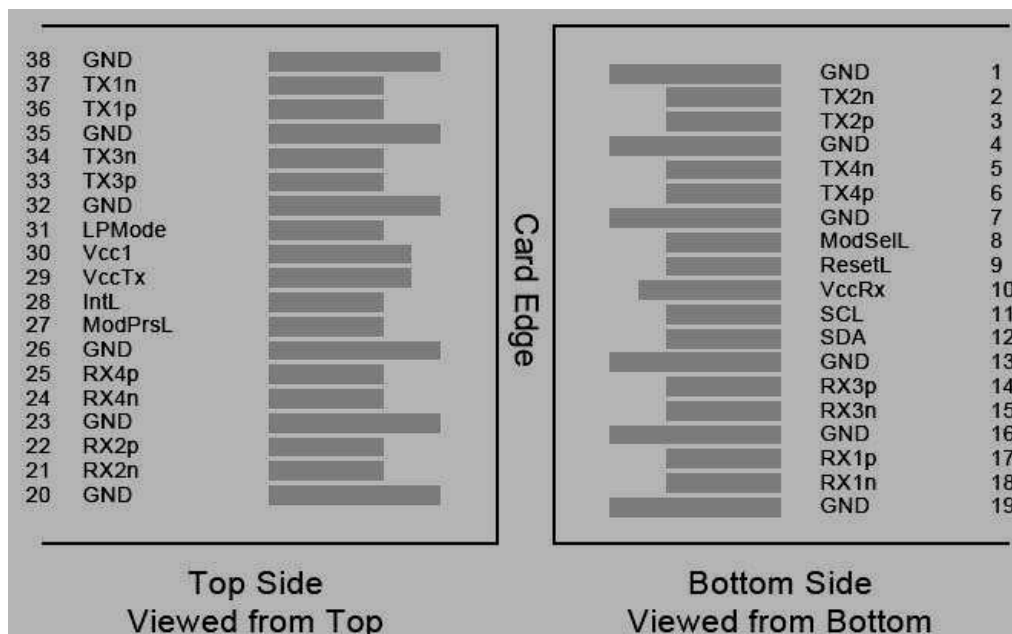

Figure 2: MSA compliant Connector

Pin Definitions

PIN	Logic	Symbol	Name/Description	Note
1		GND	Ground	1
2	CML-I	Tx2n	Transmitter Inverted Data Input	
3	CML-I	Tx2p	Transmitter Non-Inverted Data output	
4		GND	Ground	1
5	CML-I	Tx4n	Transmitter Inverted Data Input	
6	CML-I	Tx4p	Transmitter Non-Inverted Data output	
7		GND	Ground	1
8	LVTLL-I	ModSelL	Module Select	
9	LVTLL-I	ResetL	Module Reset	
10		VccRx	+ 3.3V Power Supply Receiver	2
11	LVC MOS-I/O	SCL	2-Wire Serial Interface Clock	
12	LVC MOS-I/O	SDA	2-Wire Serial Interface Data	
13		GND	Ground	
14	CML-O	Rx3p	Receiver Non-Inverted Data Output	
15	CML-O	Rx3n	Receiver Inverted Data Output	
16		GND	Ground	1
17	CML-O	Rx1p	Receiver Non-Inverted Data Output	
18	CML-O	Rx1n	Receiver Inverted Data Output	
19		GND	Ground	1
20		GND	Ground	1
21	CML-O	Rx2n	Receiver Inverted Data Output	
22	CML-O	Rx2p	Receiver Non-Inverted Data Output	
23		GND	Ground	1
24	CML-O	Rx4n	Receiver Inverted Data Output	1
25	CML-O	Rx4p	Receiver Non-Inverted Data Output	
26		GND	Ground	1
27	LVTTL-O	ModPrsL	Module Present	
28	LVTTL-O	IntL	Interrupt	
29		VccTx	+3.3 V Power Supply transmitter	2
30		Vcc1	+3.3 V Power Supply	2
31	LVTTL-I	LPMODE	Low Power Mode	
32		GND	Ground	1

33	CML-I	Tx3p	Transmitter Non-Inverted Data Input	
34	CML-I	Tx3n	Transmitter Inverted Data Output	
35		GND	Ground	1
36	CML-I	Tx1p	Transmitter Non-Inverted Data Input	
37	CML-I	Tx1n	Transmitter Inverted Data Output	
38		GND	Ground	1

Notes:

1. GND is the symbol for signal and supply (power) common for QSFP modules. All are common within the QSFP module and all module voltages are referenced to this potential unless otherwise noted. Connect these directly to the host board signal common ground plane.
2. VccRx, Vcc1 and VccTx are the receiving and transmission power suppliers and shall be applied concurrently. Recommended host board power supply filtering is shown below. VccRx, Vcc1 and VccTx may be internally connected within the QSFP transceiver module in any combination. The connector pins are each rated for a maximum current of 500mA.

Absolute Maximum Ratings

It has to be noted that the operation in excess of any individual absolute maximum ratings might cause permanent damage to this module.

Parameter	Symbol	Min	Max	Unit	Note
Storage Temperature	Tst	-20	85	degC	
Relative Humidity (non-condensation)	RH	0	85	%	
Operating Case Temperature	Topc	0	70	degC	
Operating Range		0.002	10	km	
Supply Voltage	VCC	-0.5	3.6	V	

Optical Characteristics

Parameter	Symbol	Min.	Typical	Max	Unit	Notes
Wavelength Assignment	L0	1264.5	1271	1277.5	nm	
	L1	1284.5	1291	1297.5	nm	
	L2	1304.5	1311	1317.5	nm	
	L3	1324.5	1331	1337.5	nm	
Transmitter						
Side-mode Suppression Ratio	SMSR	30	-	-	dB	
Total Average Launch Power	P_T	-	-	8.3	dBm	
Average Launch Power, each Lane		-7	-	2.3	dBm	
Optical Modulation Amplitude, each Lane	OMA	-4	-	+3.5	dBm	
Difference in Launch Power between any two Lanes (OMA)		-	-	6.5	dB	
Launch Power in OMA minus Transmitter and Dispersion Penalty (TDP), each Lane		-4.8	-		dBm	
TDP, each Lane	TDP			2.3	dB	
Extinction Ratio	ER	3.5	-	-	dB	
Relative Intensity Noise	R_{in}	-	-	-128	dB/Hz	12dB reflection
Optical Return Loss Tolerance		-	-	20	dB	
Transmitter Reflectance	R_T			-12	dB	
Transmitter Eye Mask Definition {X1, X2, X3, Y1, Y2, Y3}		{0.25,0.4,0.45,0.25,0.28,0.4}				
Average Launch Power OFF Transmitter, each Lane	P_{off}			-30	dBm	

Receiver						
Damage Threshold	TH _d	3.3			dBm	1
Average Power at Receiver Input, each Lane		-13.7		2.3	dBm	
Receiver Reflectance	R _R	-	-	-26	dB	
Receiver Power (OMA), each Lane		-	-	3.5	dBm	
Stressed Receiver Sensitivity in OMA, each Lane		-	-	-9.9	dBm	
Receiver Sensitivity, each Lane	S _R	-	-	-11.5	dBm	
Difference in Receive Power between any two Lanes (OMA)				7.5	dB	
Receive Electrical 3 dB upper Cutoff Frequency, each Lane				12.3	GHz	
Conditions of Stress Receiver Sensitivity Test²						
Vertical Eye Closure Penalty, each Lane			1.6		dB	
Stressed Eye Jitter, each Lane			0.3		UI	

Notes:

1. The receiver shall be able to tolerate, without damage, continuous exposure to a modulated optical input signal having this power level on one lane. The receiver does not have to operate correctly at this input power.
2. Vertical eye closure penalty and stressed eye jitter are test conditions for measuring stressed receiver sensitivity. They are not characteristics of the receiver.

Electrical Characteristics

The following electrical characteristics are defined over the Recommended Operating temperature and supply voltage unless otherwise specified.

Parameter	Symbol	Min.	Typical	Max	Unit	Notes
Supply Voltage	V _{ccI} , V _{ccTx} , V _{ccRx}	-0.5	-	3.6	V	
Data Rate, each Lane		-	10.3125	11.2	Gbps	

Mechanical Design Diagram

Unit: mm

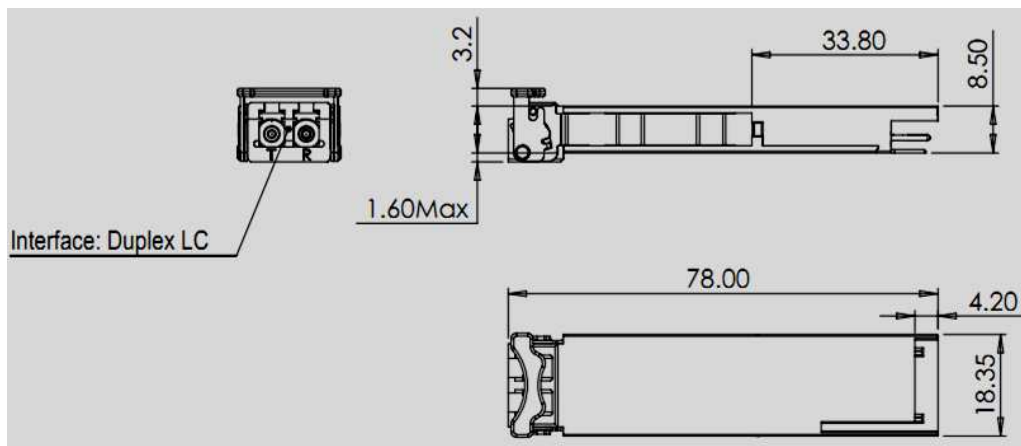

ESD

This transceiver is specified as ESD threshold 2kV for all electrical input pins, tested per MIL-STD-883, Method 3015.4 /JESD22-A114-A (HBM). However, normal ESD precautions are still required during the handling of this module. This transceiver is shipped in ESD protective packaging. It should be removed from the packaging and handled only in an ESD protected environment.

Laser Safety

This is a Class 1 Laser Product according to IEC 60825-1:1993:+A1:1997+A2:2001. This product complies with 21 CFR 1040.10 and 1040.11 except for deviations pursuant to Laser Notice No. 50, dated (July 26, 2001)

Memory Map

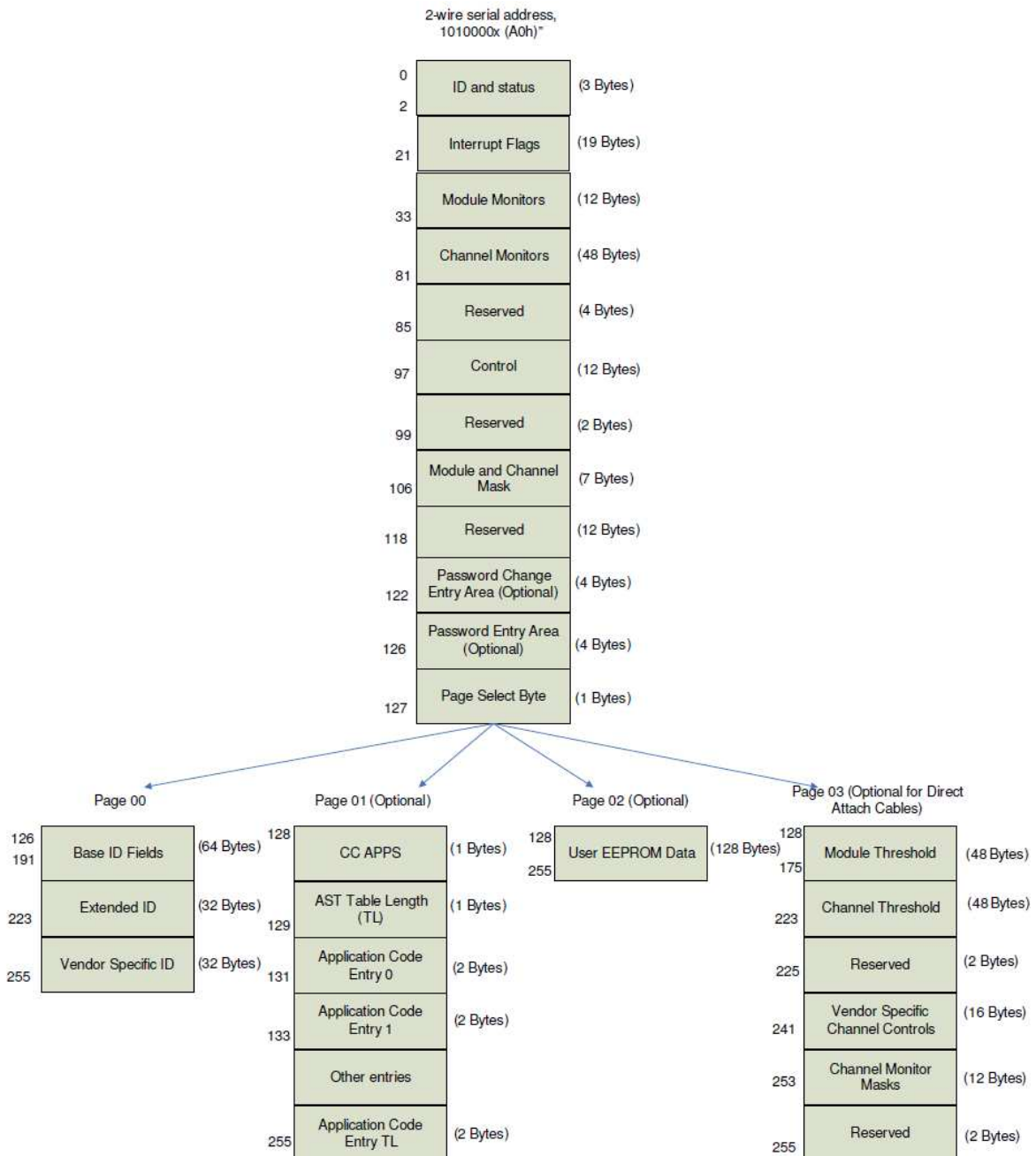

Contention 2-Wire Address A0H

Address	Description	Default/Typical value
0	Identifier	0D
1	Reserved	00
2	Status	00
3	Rx LOS	FF
4	Tx Fault	0F
6	Temp High/Low alarm/warning	01
7	Vcc high/low alarm/ warning	00
22-25	Reserved	00
26-27	Supply voltage	83,7A
28-41	Reserved	00
42-49	Tx bias	37,11,47,74,3D,29,4A,1D
50-85	Reserved	00
86	Tx disable	00
87-106	Reserved	00
100-106	Module and Channel Masks	
107-118	Reserved	00
119-122	Password Change Entry Area (optional)	
123-126	Password Entry Area (optional)	
127	Page Select Byte	00

Address	Description	Default/Typical value
128	Identifier	0D
129	Ext. Identifier	C4
130	Connector	07
131-138	Module	02, 00, 00, 02, 10, 10, 01, 80
139	Encoding	03
140	BR, nominal	67
141	Extended rate select Compliance	00
142	Length(SMF)	0A
143	Length(OM3 50 um)	00
144	Length(OM2 50 um)	00
145	Length(OM1 62.5 um)	00
146	Length(Copper)	00
147	Device tech	40
148-163	Vendor name	46,4F,52,4D,45,52,49,43,41,4F,45,20,20,20,20,20
164	Extended Module	07
165-167	Vendor OUI	00, 00, 00
168-183	Vendor PN	54,43,57,2D,51,31,4C,41,41,2D,46,43,51,20,20,20
184-185	Vendor rev	31, 41
186-187	Wave length or Copper cable Attenuation	65, 90
188-189	Wavelength tolerance	17, 70
190	Max case temp.	46
191	CC_BASE	
192-195	Options	00, 00, 00
196-211	Vendor SN	
212-219	Date Code	
220	Diagnostic Monitoring Type	08
221-222	Enhanced Options	00
222	Reserved	00
223	CC_EXT	
224-255	Vendor Specific	

Address	Description	Default/Typical value
128-129	Temp high alarm(80)	50,00
130-131	Temp low alarm(-10)	F6,00
132-133	Temp high warning(75)	4B,00
134-135	Temp low warning(-5)	FB,00
144-145	Vcc high alarm(3.7V)	90,88
146-147	Vcc low alarm(2.9V)	71,70
148-149	Vcc high warning(3.6V)	8C,70
150-151	Vcc low warning (3.0V)	75,48
176-177	Rx power high alarm(4.5dBm)	6E,18
178-179	Rx power low alarm(-12.5dBm)	02,32
180-181	Rx power high warning(4.0dBm)	62,1F
182-183	Rx power low warning(-11.5dBm)	02,C4
184-185	Tx bias high alarm(75mA)	92,7C
186-187	Tx bias low alarm(10mA)	13,88
188-189	Tx bias high warning(70mA)	88,B8
190-191	Tx bias low warning(15mA)	1D,4C