



Chipsmall Limited consists of a professional team with an average of over 10 year of expertise in the distribution of electronic components. Based in Hongkong, we have already established firm and mutual-benefit business relationships with customers from,Europe,America and south Asia,supplying obsolete and hard-to-find components to meet their specific needs.

With the principle of “Quality Parts,Customers Priority,Honest Operation,and Considerate Service”,our business mainly focus on the distribution of electronic components. Line cards we deal with include Microchip,ALPS,ROHM,Xilinx,Pulse,ON,Everlight and Freescale. Main products comprise IC,Modules,Potentiometer,IC Socket,Relay,Connector.Our parts cover such applications as commercial,industrial, and automotives areas.

We are looking forward to setting up business relationship with you and hope to provide you with the best service and solution. Let us make a better world for our industry!



Contact us

Tel: +86-755-8981 8866 Fax: +86-755-8427 6832

Email & Skype: info@chipsmall.com Web: www.chipsmall.com

Address: A1208, Overseas Decoration Building, #122 Zhenhua RD., Futian, Shenzhen, China



DATA SHEET

TDA1072AT AM receiver circuit

Product specification
File under Integrated Circuits, IC01

March 1989

AM receiver circuit**TDA1072AT****GENERAL DESCRIPTION**

The TDA 1072AT integrated AM receiver circuit performs the active and part of the filtering functions of an AM radio receiver. It is intended for use in mains-fed home receivers and car radios. The circuit can be used for oscillator frequencies up to 50 MHz and can handle RF signals up to 500 mV. RF radiation and sensitivity to interference are minimized by an almost symmetrical design. The voltage-controlled oscillator provides signals with extremely low distortion and high spectral purity over the whole frequency range even when tuning with variable capacitance diodes. If required, band switching diodes can easily be applied. Selectivity is obtained using a block filter before the IF amplifier.

Features

- Inputs protected against damage by static discharge
- Gain-controlled RF stage
- Double balanced mixer
- Separately buffered, voltage-controlled and temperature-compensated oscillator, designed for simple coils
- Gain-controlled IF stage with wide AGC range
- Full-wave, balanced envelope detector
- Internal generation of AGC voltage with possibility of second-order filtering
- Buffered field strength indicator driver with short-circuit protection
- AF preamplifier with possibilities for simple AF filtering
- Electronic standby switch.

QUICK REFERENCE DATA

PARAMETER	CONDITIONS	SYMBOL	MIN.	TYP.	MAX.	UNIT
Supply voltage range		V_P	7.5	–	10	V
Supply current range		I_P	15	–	26	mA
RF input voltage for S+N/N = 6 dB at m = 30%		V_I	–	1.5	–	μ V
RF input voltage for 3% total harmonic distortion (THD) at m = 80%		V_I	–	500	–	mV
AF output voltage with $V_I = 2$ mV; $f_I = 1$ MHz; m = 30% and $f_m = 400$ Hz		$V_{O(AF)}$	–	310	–	mV
AGC range: change of V_I for 1 dB change of $V_{O(AF)}$			–	86	–	dB
Field strength indicator voltage at $V_I = 500$ mV; $R_{L(9)} = 2.7$ k Ω		V_{IND}	–	2.8	–	V

PACKAGE OUTLINE

16-lead mini-pack; plastic (SO16; SOT109A); SOT109-1; 1996 August 13.

AM receiver circuit

TDA1072AT

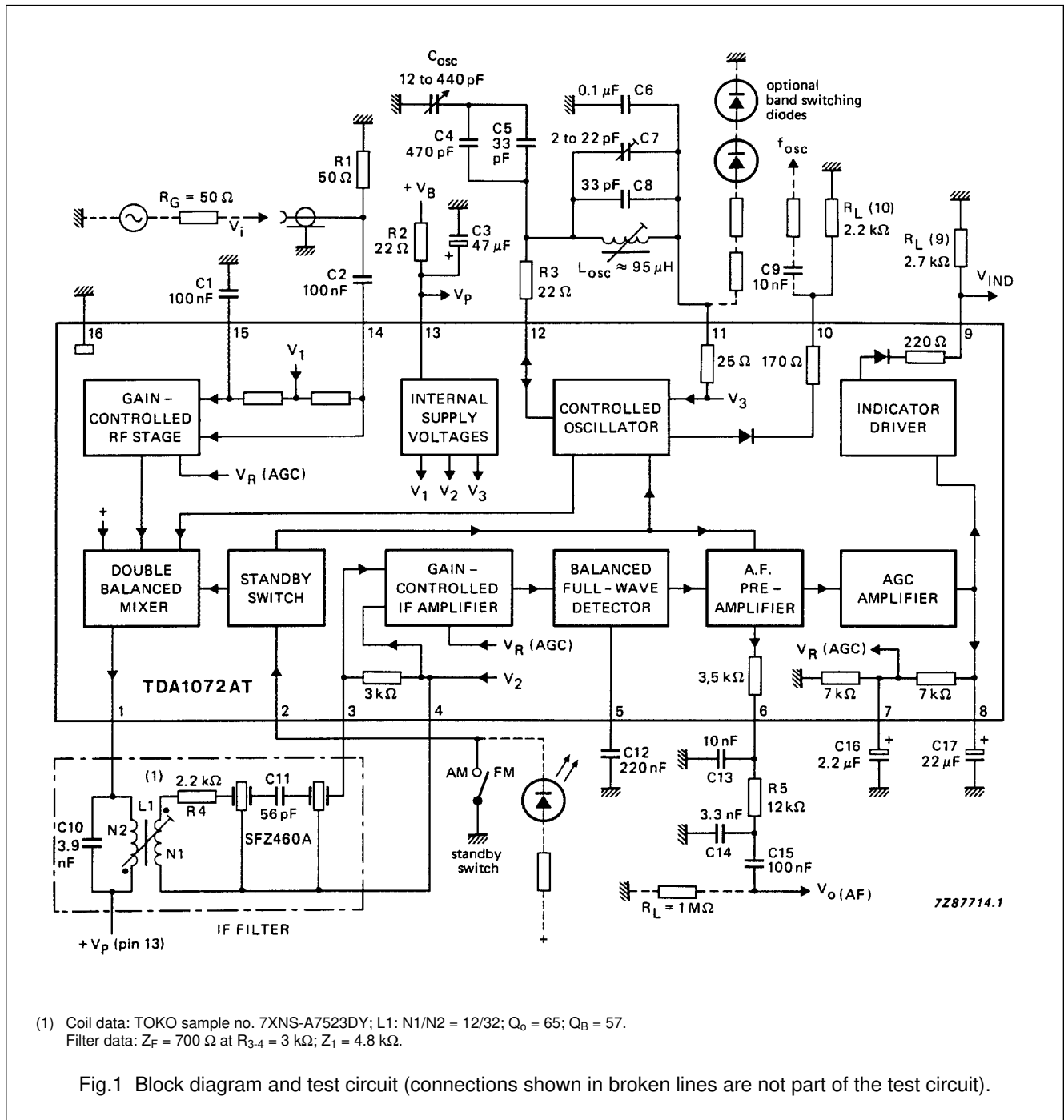

AM receiver circuit

TDA1072AT

FUNCTIONAL DESCRIPTION

Gain-controlled RF stage and mixer

The differential amplifier in the RF stage employs an AGC negative feedback network to provide a wide dynamic range. Very good cross-modulation behaviour is achieved by AGC delays at the various signal stages. Large signals are handled with low distortion and the S/N ratio of small signals is also improved. Low noise working is achieved in the differential amplifier by using transistors with a low base resistance.

A double balanced mixer provides the IF output to pin 1.

Oscillator

The differential amplifier oscillator is temperature compensated and is suitable for simple coil connection. The oscillator is voltage-controlled and has little distortion or spurious radiation. It is specially suitable for electronic tuning using variable capacitance diodes. Band switching diodes can easily be applied using the stabilized voltage V_{11-16} . An extra buffered oscillator output is available for driving a synthesizer. If this is not needed, resistor $R_{L(10)}$ can be omitted.

Gain-controlled IF amplifier

This amplifier comprises two cascaded, variable-gain differential amplifier stages coupled by a band-pass filter. Both stages are gain-controlled by the AGC negative feedback network.

Detector

The full-wave, balanced envelope detector has very low distortion over a wide dynamic range. The residual IF carrier is blocked from the signal path by an internal low-pass filter.

AF preamplifier

This stage preamplifies the audio frequency output. The amplifier output stage uses an emitter follower with a series resistor which, together with an external capacitor, provides the required low-pass filtering for AF signals.

AGC amplifier

The AGC amplifier provides a control voltage which is proportional to the carrier amplitude. Second-order filtering of the AGC voltage achieves signals with very little distortion, even at low audio frequencies. This method of filtering also gives a fast AGC settling time which is advantageous for electronic search tuning. The AGC settling time can be further reduced by using capacitors of smaller value in the external filter. The AGC voltage is fed to the RF and IF stages via suitable AGC delays. The capacitor at pin 7 can be omitted for low-cost applications.

Field strength indicator output

A buffered voltage source provides a high-level field strength output signal which has good linearity for logarithmic input signals over the whole dynamic range. If field strength information is not needed, $R_{L(9)}$ can be omitted.

Standby switch

This switch is primarily intended for AM/FM band switching. During standby mode the oscillator, mixer and demodulator are switched off.

Short-circuit protection

All pins have short-circuit protection to ground.

AM receiver circuit

TDA1072AT

RATINGS

Limiting values in accordance with the Absolute Maximum Rating System (IEC 134)

PARAMETER	CONDITIONS	SYMBOL	MIN.	MAX.	UNIT
Supply voltage	$V_P = V_{13-16}$	V_{13}	–	12	V
Input voltage					
pins 14-15		V_{14-15}	–	10	V
pins 14-16		V_{14-16}	–	V_P	V
pins 15-16		V_{15-16}	–	V_P	V
pins 14-16		V_{14-16}	–	–0.6	V
pins 15-16		V_{15-16}	–	–0.6	V
Input current					
(pins 14 and 15)		I_{14-15}	–	200	mA
Total power dissipation (note 1)		P_{tot}	–	300	mW
Operating ambient temperature range		T_{amb}	–40	+ 80	°C
Storage temperature range		T_{stg}	–55	+ 150	°C
Junction temperature		T_j	–	+ 125	°C

Note

1. Mounted on epoxiprint.

THERMAL RESISTANCE

From junction to ambient

 $R_{th\ j-a}$

300 K/W

160 K/W⁽¹⁾**Note**

1. Mounted on epoxiprint.

AM receiver circuit

TDA1072AT

CHARACTERISTICS

$V_P = V_{13-16} = 8.5 \text{ V}$; $T_{\text{amb}} = 25 \text{ }^\circ\text{C}$; $f_i = 1 \text{ MHz}$; $f_m = 400 \text{ Hz}$; $m = 30\%$; $f_{IF} = 460 \text{ kHz}$; measured in test circuit of Fig.1; all measurements are with respect to ground (pin 16); unless otherwise specified

PARAMETER	CONDITIONS	SYMBOL	MIN.	TYP.	MAX.	UNIT
Supplies						
Supply voltage (pin 13)		V_{13}	7.5	8.5	10	V
Supply current (pin 13)		I_{13}	15	23	27	mA
RF stage and mixer						
Input voltage (DC value)		V_{14-15}	—	$V_P / 2$	—	V
RF input impedance at $V_I < 300 \mu\text{V}$		R_{14-15}	—	5.5	—	k Ω
		C_{14-15}	—	25	—	pF
RF input impedance at $V_I > 10 \text{ mV}$		R_{14-15}	—	8	—	k Ω
		C_{14-15}	—	22	—	pF
IF output impedance		R_1	500	0	0	k Ω
		C_1	—	6	—	pF
Conversion transconductance before start of AGC		I_1/V_I	—	6.5	—	mA/V
Maximum IF output voltage, inductive coupling to pin 1, (peak-to-peak value)		$V_{1(p-p)}$	—	5	—	V
DC value of output current (pin 1) at $V_I = 0 \text{ V}$		I_1	—	1.2	—	mA
AGC range of input stage			—	30	—	dB
RF signal handling capability: input voltage for THD = 3% at $m = 80\%$ (RMS value)		$V_{I(\text{rms})}$	—	500	—	mV
Oscillator						
Frequency range		Δf	0.6	—	60	MHz
Oscillator amplitude (pins 11 to 12) (peak-to-peak value)		$V_{11-12(p-p)}$	—	130	150	mV
External load impedance		$R_{11-12(\text{ext})}$	0.5	—	200	k Ω
External load impedance for no oscillation		$R_{11-12(\text{ext})}$	—	—	60	Ω
Ripple rejection at V_P = 100 mV (RMS value); $f_p = 100 \text{ Hz}$ ($RR = 20 \log [V_{13}/V_{11}]$)						

AM receiver circuit

TDA1072AT

PARAMETER	CONDITIONS	SYMBOL	MIN.	TYP.	MAX.	UNIT
Source voltage for switching diodes ($6 \times V_{BE}$)		V_{11}	–	4.2	–	V
DC output current (for switching diodes)	$V_P = V_{13}$ ≤ 9 V	I_{11}	0	–	5	mA
Change of output voltage at $\Delta I_{11} = 20$ mA (switch to maximum load)		ΔV_{11}	–	0.5	–	V
Buffered oscillator output						
DC output voltage		V_{10}	–	0.7	–	V
Output signal amplitude (peak-to-peak value)		$V_{10(p-p)}$	–	320	–	mV
Output impedance		R_{10}	–	170	–	Ω
Output current		$I_{10(\text{peak})}$	–	–	–3	mA
IF, AGC and AF stages						
DC input voltage		V_{3-4}	–	2	–	V
IF input impedance		R_{3-4} C_{3-4}	2.4	3.0	3.9	k Ω pF
IF input voltage for THD = 3% at $m = 80\%$		V_{3-4}	–	90	–	mV
Voltage gain before start of AGC		V_{3-4}/V_6	–	68	–	dB
AGC range of IF stages: change of V_{3-4} for 1 dB change of $V_{O(AF)}$; $V_{3-4(\text{ref})} = 75$ mV		ΔV_{3-4}	–	55	–	dB
AF output voltage at $V_{3-4(IF)} = 50$ μ V		$V_{O(AF)}$	–	130	–	mV
AF output voltage at $V_{3-4(IF)} = 1$ mV		$V_{O(AF)}$	–	310	–	mV
AF output impedance (pin 6)		$ Z_O $	–	3.5	–	k Ω
Indicator driver						
Output voltage at $V_I = 0$ mV	$R_{L(9)} = 2.7$ k Ω	V_9	–	20	150	mV
Output voltage at $V_I = 500$ mV	$R_{L(9)} = 2.7$ k Ω	V_9	2.5	2.8	3.1	V
Load resistance		$R_{L(9)}$	2.7	–	–	k Ω

AM receiver circuit

TDA1072AT

PARAMETER	CONDITIONS	SYMBOL	MIN.	TYP.	MAX.	UNIT
Standby switch						
Switching threshold at						
$V_P = 7.5$ to 18 V;						
$T_{amb} = -40$ to $+80$ °C						
ON-voltage		V_2	0	–	2	V
OFF-voltage		V_2	3.5	–	20	V
ON-current	$V_2 = 0$ V	I_2	–	–	–200	µA
OFF-current	$V_2 = 20$ V	I_2	–	–	10	µA

OPERATING CHARACTERISTICS

$V_P = 8.5$ V; $f_i = 1$ MHz; $m = 30\%$; $f_m = 400$ Hz; $T_{amb} = 25$ °C; measured in Fig.1; unless otherwise specified

PARAMETER	CONDITIONS	SYMBOL	MIN.	TYP.	MAX.	UNIT
RF sensitivity						
RF input required for						
$S+N/N = 6$ dB		V_I	–	1.5	–	µV
$S+N/N = 26$ dB		V_I	–	15	–	µV
$S+N/N = 46$ dB		V_I	–	150	–	µV
RF input at start of AGC		V_I	–	30	–	µV
RF large signal handling						
RF input at						
THD = 3%; $m = 80\%$		V_I	–	500	–	mV
THD = 3%; $m = 30\%$		V_I	–	700	–	mV
THD = 10%; $m = 30\%$		V_I	–	900	–	mV
AGC range						
Change of V_I for						
1 dB change of $V_{O(AF)}$	$V_{I(ref)} = 500$ mV	ΔV_I	–	86	–	dB
6 dB change of $V_{O(AF)}$	$V_{I(ref)} = 500$ mV	ΔV_I	–	91	–	dB
Output signal						
AF output voltage at						
$V_I = 4$ µV	$m = 80\%$	$V_{O(AF)}$	–	130	–	mV
$V_I = 1$ mV		$V_{O(AF)}$	240	310	390	mV
Total harmonic distortion at						
$V_I = 1$ mV	$m = 80\%$	d_{tot}	–	0.5	–	%
$V_I = 500$ mV	$m = 30\%$	d_{tot}	–	1	–	%
Signal-to-noise ratio	$V_I = 100$ mV	$S+N/N$	–	58	–	dB

AM receiver circuit

TDA1072AT

PARAMETER	CONDITIONS	SYMBOL	MIN.	TYP.	MAX.	UNIT
Ripple rejection at $V_I = 2 \text{ mV}$ $V_P = 100 \text{ mV}$ (RMS value) $f_p = 100 \text{ Hz}$ (RR = 20 log [V _P /V _{O(AF)}])		RR	—	38	—	dB
Unwanted signals						
Suppression of IF whistles at $V_I = 15 \text{ } \mu\text{V}$; $m = 0\%$ related to AF signal of $m = 30\%$ at $f_I \approx 2 \times f_{IF}$		α_{2IF}	—	37	—	dB
at $f_I \approx 3 \times f_{IF}$		α_{3IF}	—	44	—	dB
IF suppression at RF input for symmetrical input		α_{IF}	—	40	—	dB
for asymmetrical input		α_{IF}	—	40	—	dB
Residual oscillator signal at mixer output						
at f_{osc}		$I_{(osc)}$	—	1	—	μA
at $2 \times f_{osc}$		$I_{(2osc)}$	—	1.1	—	μA

AM receiver circuit

TDA1072AT

APPLICATION INFORMATION

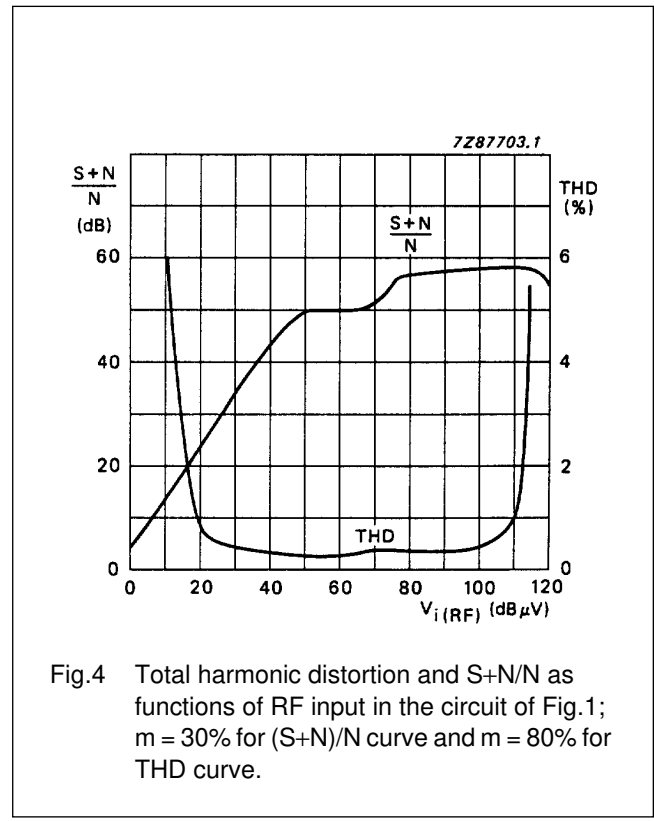
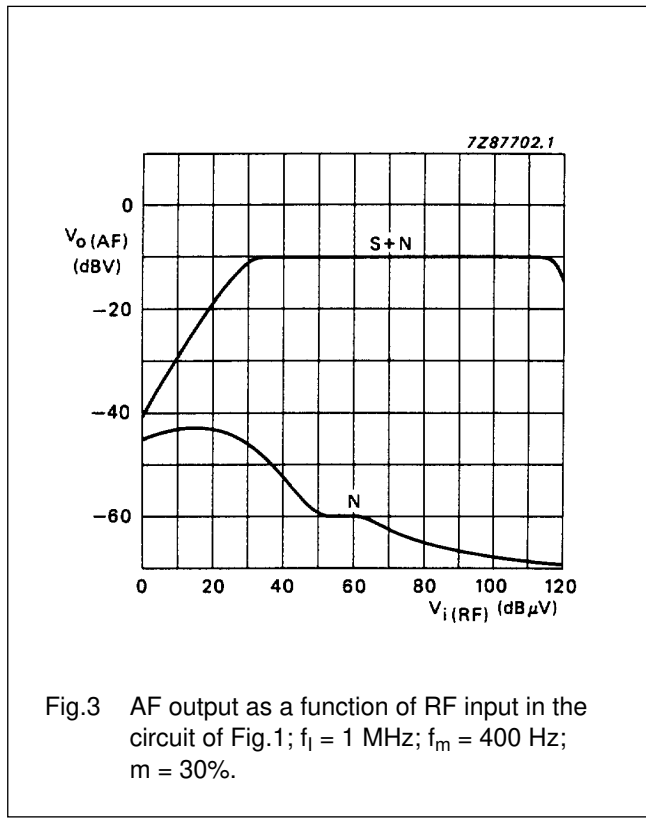
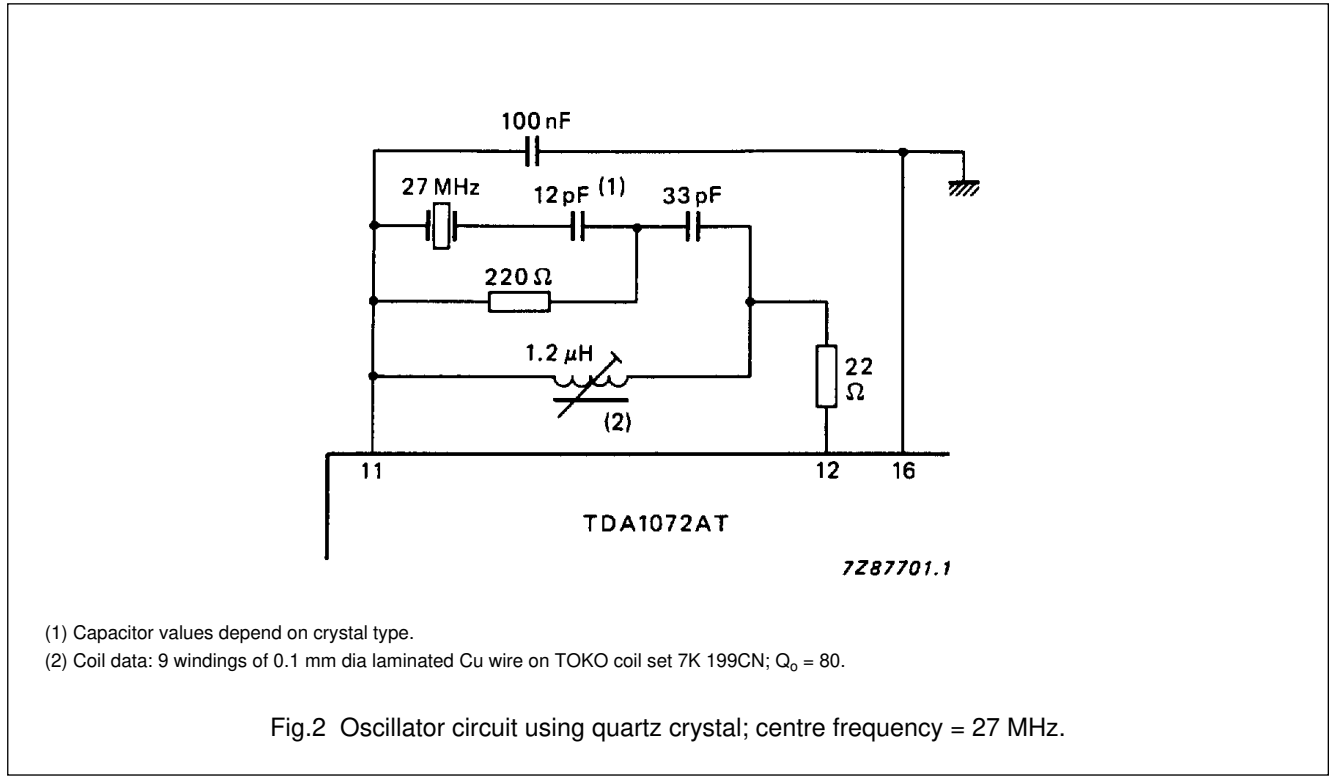

AM receiver circuit

TDA1072AT

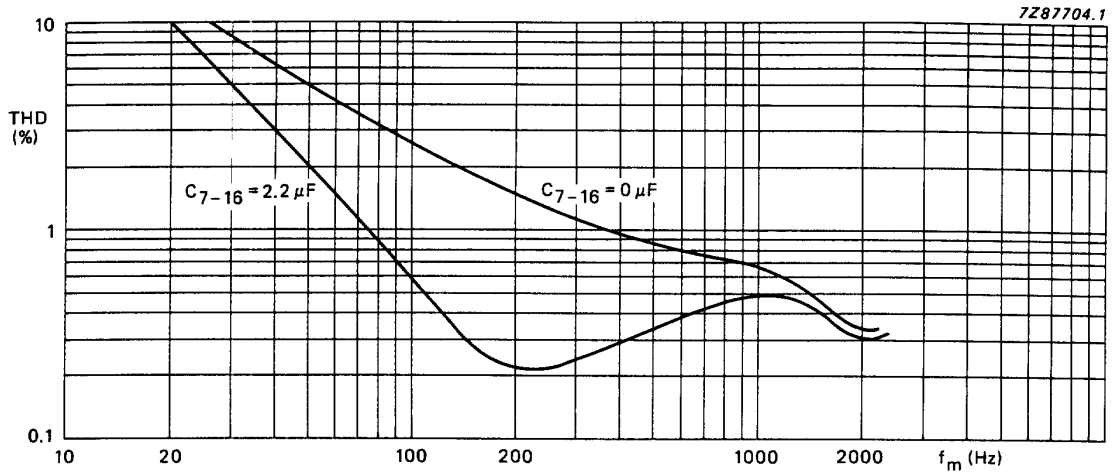

Fig.5 Total harmonic distortion as a function of modulation frequency at $V_i = 5 \text{ mV}$; $m = 80\%$; measured in the circuit of Fig.1 with $C_{7-16(\text{ext})} = 0 \mu F$ and $2.2 \mu F$.

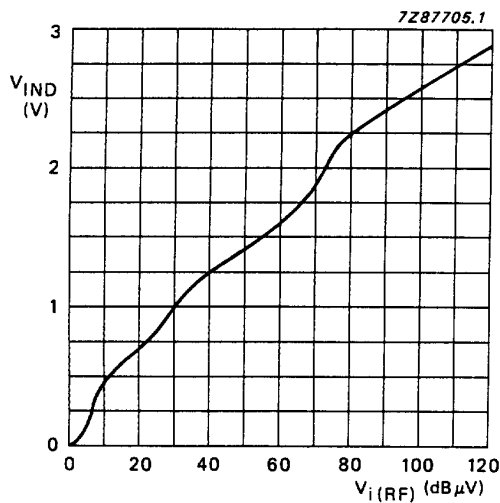

Fig.6 Indicator driver voltage as a function of RF input in the circuit of Fig.1.

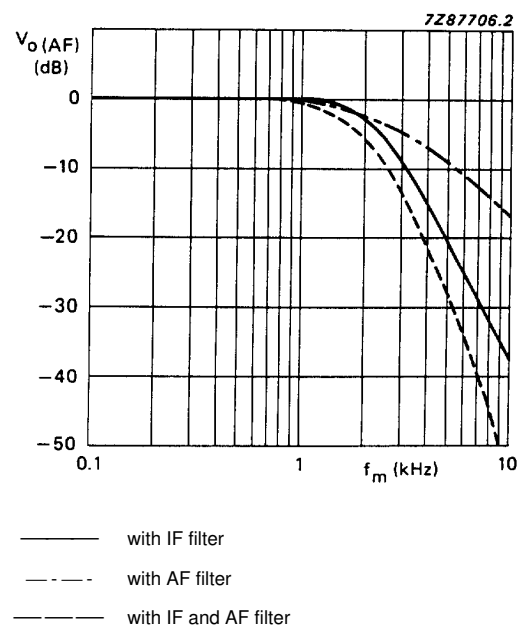

Fig.7 Typical frequency response curves from Fig.1 showing the effects of filtering.

AM receiver circuit

TDA1072AT

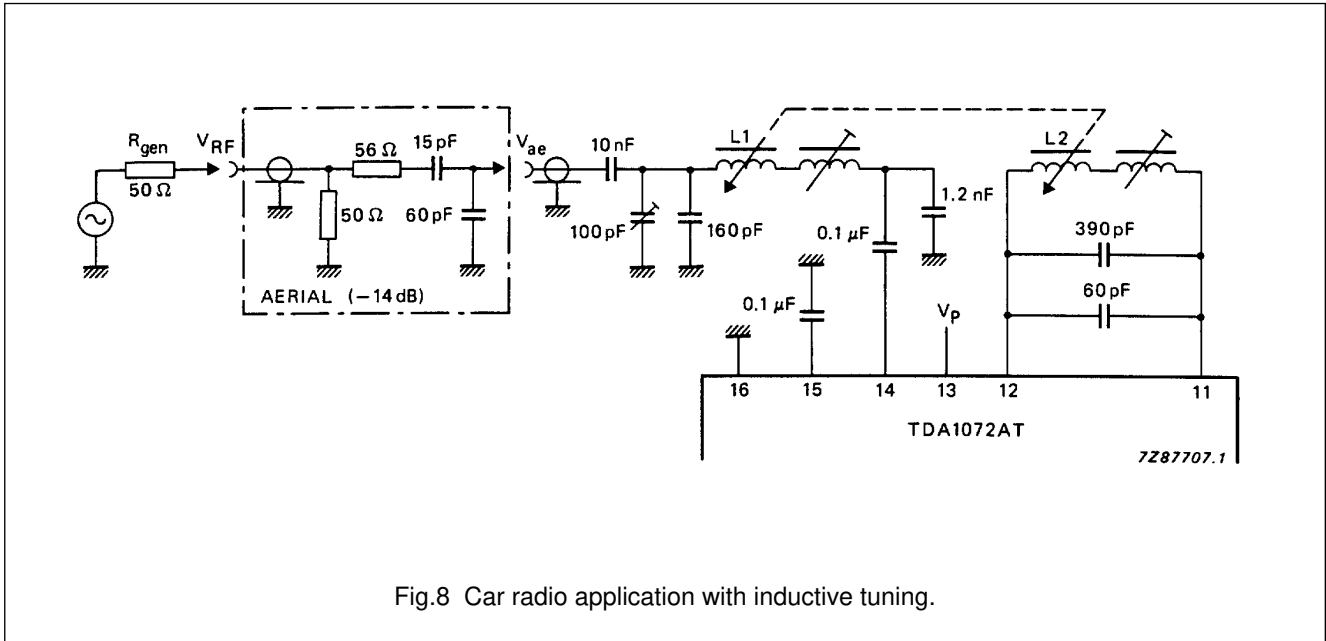

Fig.8 Car radio application with inductive tuning.

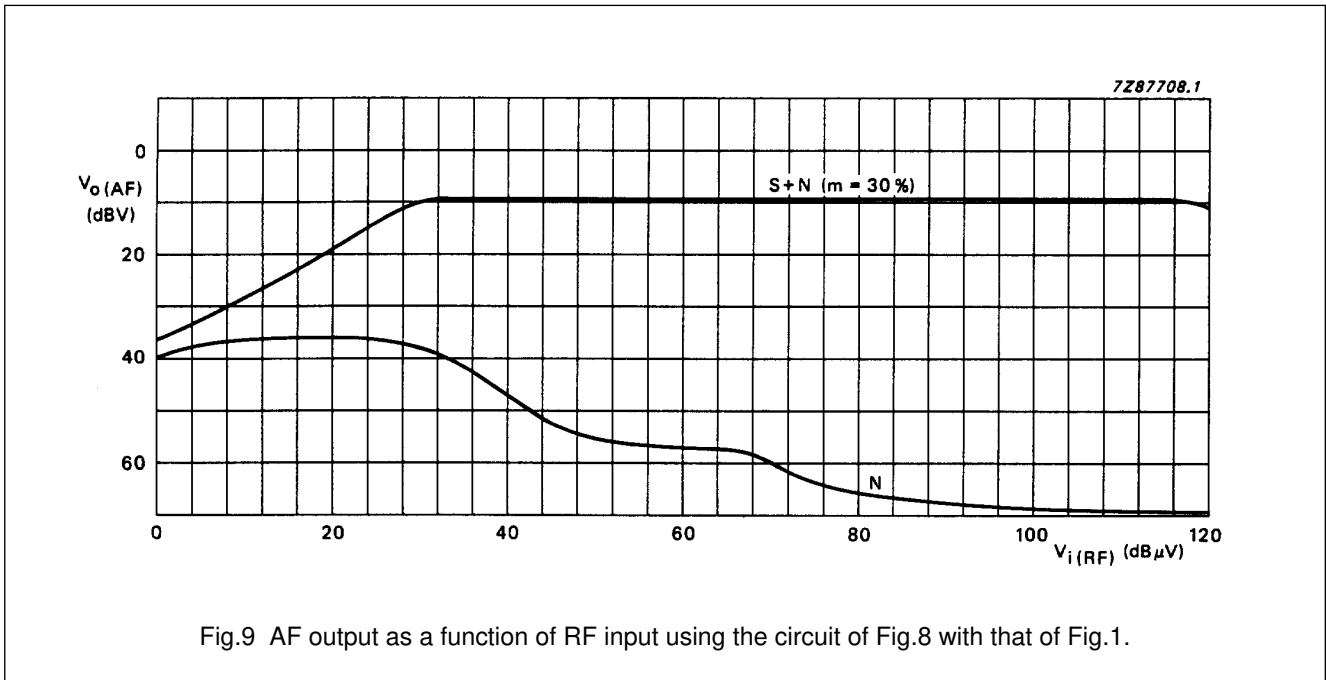

Fig.9 AF output as a function of RF input using the circuit of Fig.8 with that of Fig.1.

AM receiver circuit

TDA1072AT

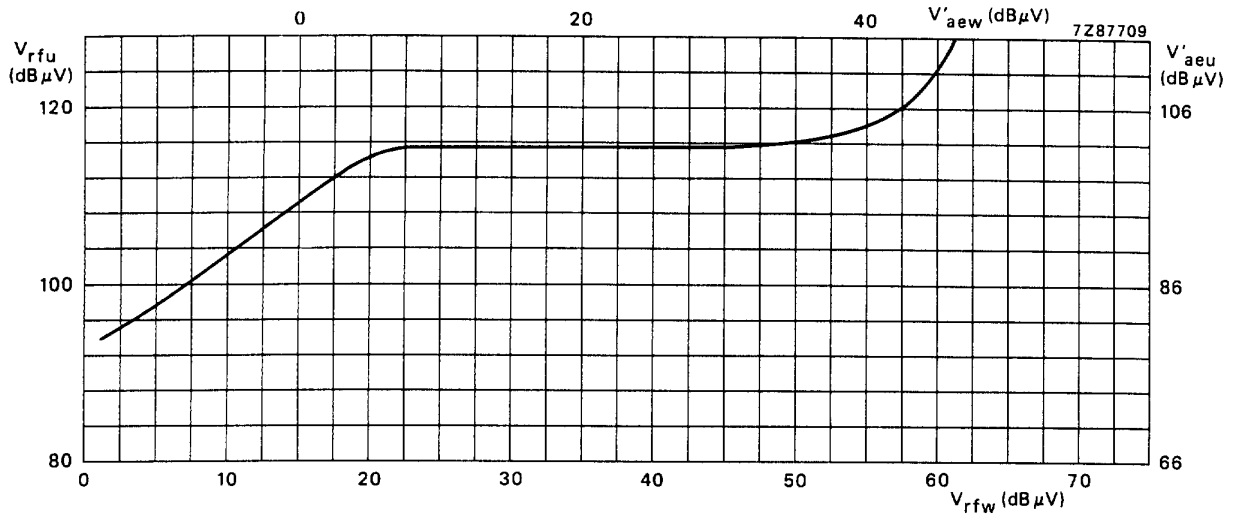

Fig.10 Suppression of cross-modulation as a function of input signal, measured in the circuit of Fig.8 with the input circuit as shown in Fig.11. Curve is for wanted $V_{O(AF)}/\text{unwanted } V_{O(AF)} = 20 \text{ dB}$; V_{rfw} , V_{rfu} are signals at the aerial input, V'_{aew} , V'_{aeu} are signals at the unloaded output of the aerial.
 Wanted signal (V'_{aew} , V_{rfw}): $f_i = 1 \text{ MHz}$; $f_m = 400 \text{ Hz}$; $m = 30\%$.
 Unwanted signal (V'_{aeu} , V_{rfu}): $f_i = 900 \text{ kHz}$; $f_m = 400 \text{ Hz}$; $m = 30\%$.
 Effective selectivity of input tuned circuit = 21 dB.

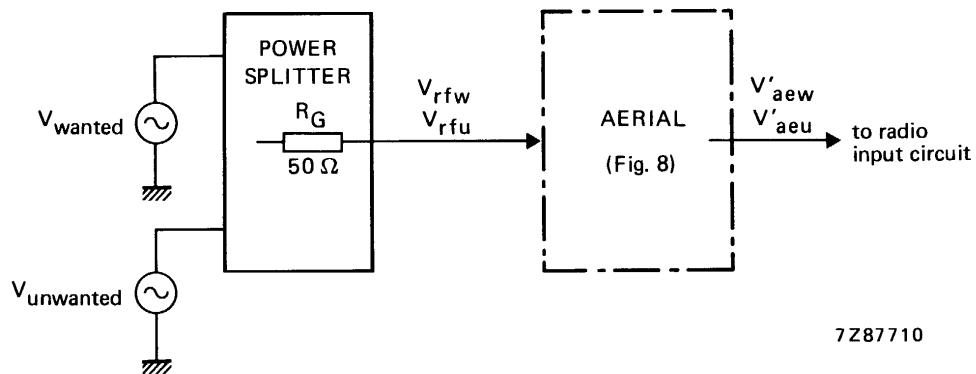

Fig.11 Input circuit to show cross-modulation suppression (see Fig.10).

AM receiver circuit

TDA1072AT

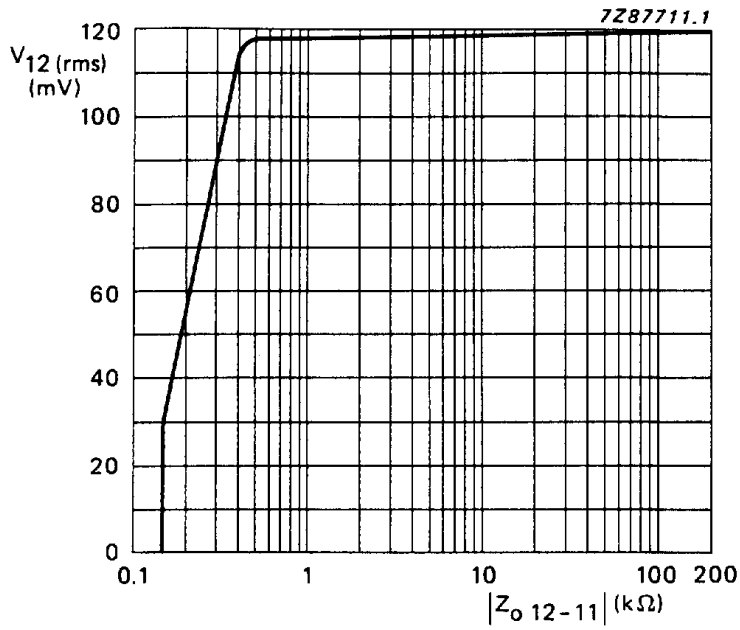

Fig.12 Oscillator amplitude as a function of the impedance at pins 11 and 12 in the circuit of Fig.8.

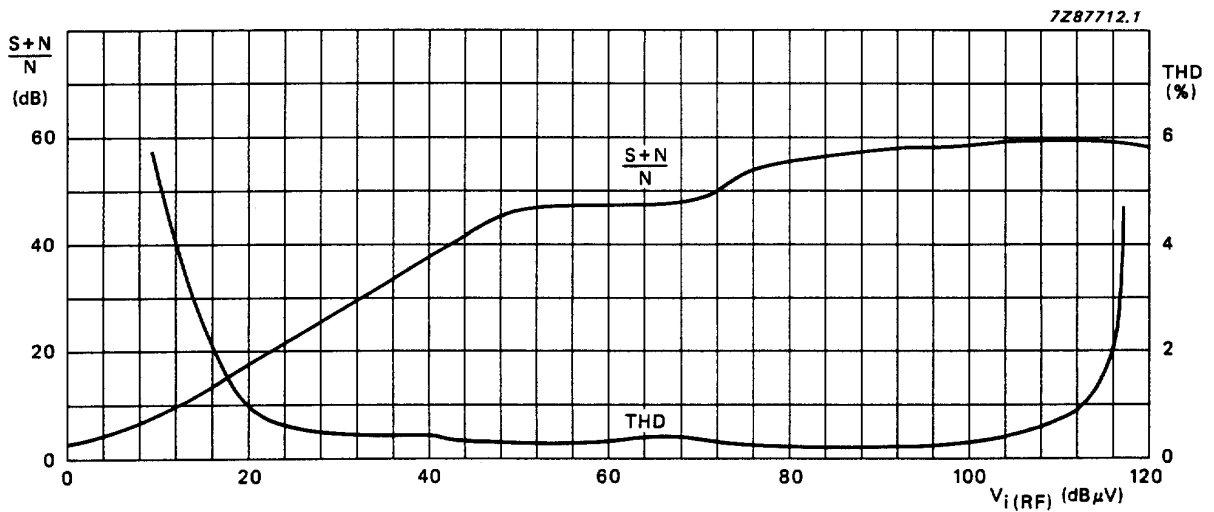

Fig.13 Total harmonic distortion and (S+N)/N as functions of RF input using the circuit of Fig.8 with that of Fig.1.

AM receiver circuit

TDA1072AT

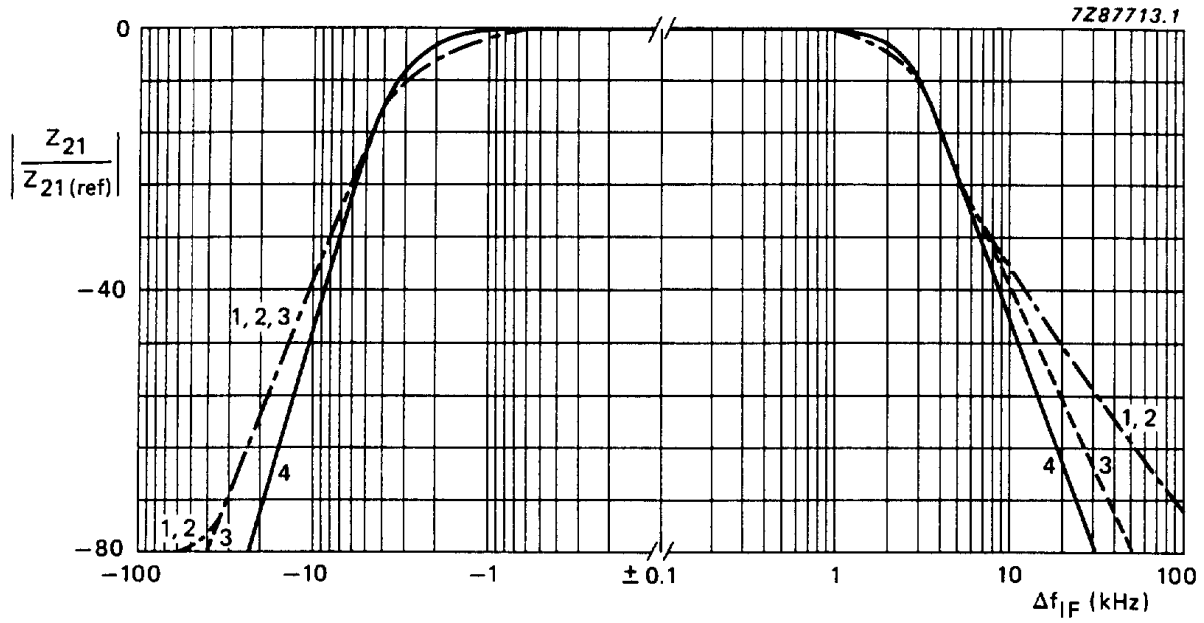

Fig.14 Forward transfer impedance as a function of intermediate frequency for filters 1 to 4 shown in Fig.14; centre frequency = 455 kHz.

AM receiver circuit

TDA1072AT

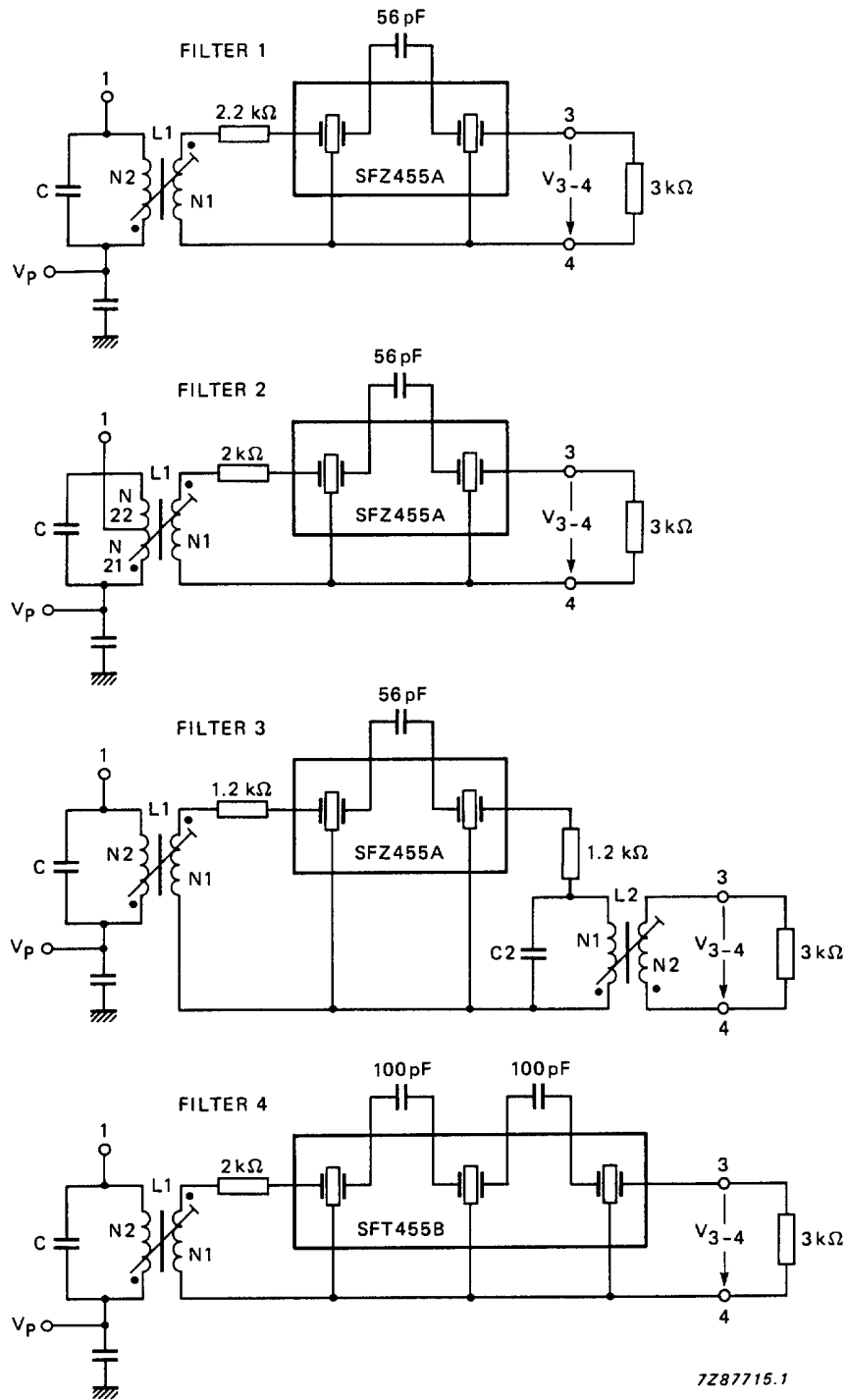

Fig.15 IF filter variants applied to the circuit of Fig.1; for filter data refer to Table 1.

AM receiver circuit

TDA1072AT

Table 1 Data for IF filters shown in Fig.15. Criterium for adjustment is Z_F = maximum (optional selectivity curve at centre frequency $f_o = 455$ kHz).
See also Fig.14.

FILTER NO.	1	2	3		4	UNIT
Coil data	L1	L1	L1	L2	L1	pF
Value of C	3900	430	3900	4700	3900	
N1: N2	12 : 32	13 : (33 + 66)	15 : 31	29 : 29	13 : 31	
Diameter of Cu laminated wire	0.09	0.08	0.09	0.08	0.09	mm
Q_o	65 (typ.)	50	75	60	75	
Schematic * of windings				(N1) (N2)		
Toko order no.	7XNS-A7523DY	L7PES-A0060BTG	7XNS-A7518DY	7XNS-A7521AIH	7XNS-A7519DY	
Resonators			SFZ455A		SFT455B	dB
Murata type	SFZ455A	SFZ455A	SFZ455A		SFT455B	
D (typical value)	4	4	4		6	
R_G, R_L	3	3	3		3	
Bandwidth (-3 dB)	4.2	4.2	4.2		4.5	
S_{9kHz}	24	24	24		38	
Filter data						k Ω
Z_I	4.8	3.8	4.2		4.8	
Q_B	57	40	52 (L1)	18 (L2)	55	
Z_F	0.70	0.67	0.68		0.68	
Bandwidth (-3 dB)	3.6	3.8	3.6		4.0	
S_{9kHz}	35	31	36		42	
S_{18kHz}	52	49	54		64	
S_{27kHz}	63	58	66		74	

* The beginning of an arrow indicates the beginning of a winding; N1 is always the inner winding. N2 the outer winding.

AM receiver circuit

TDA1072AT

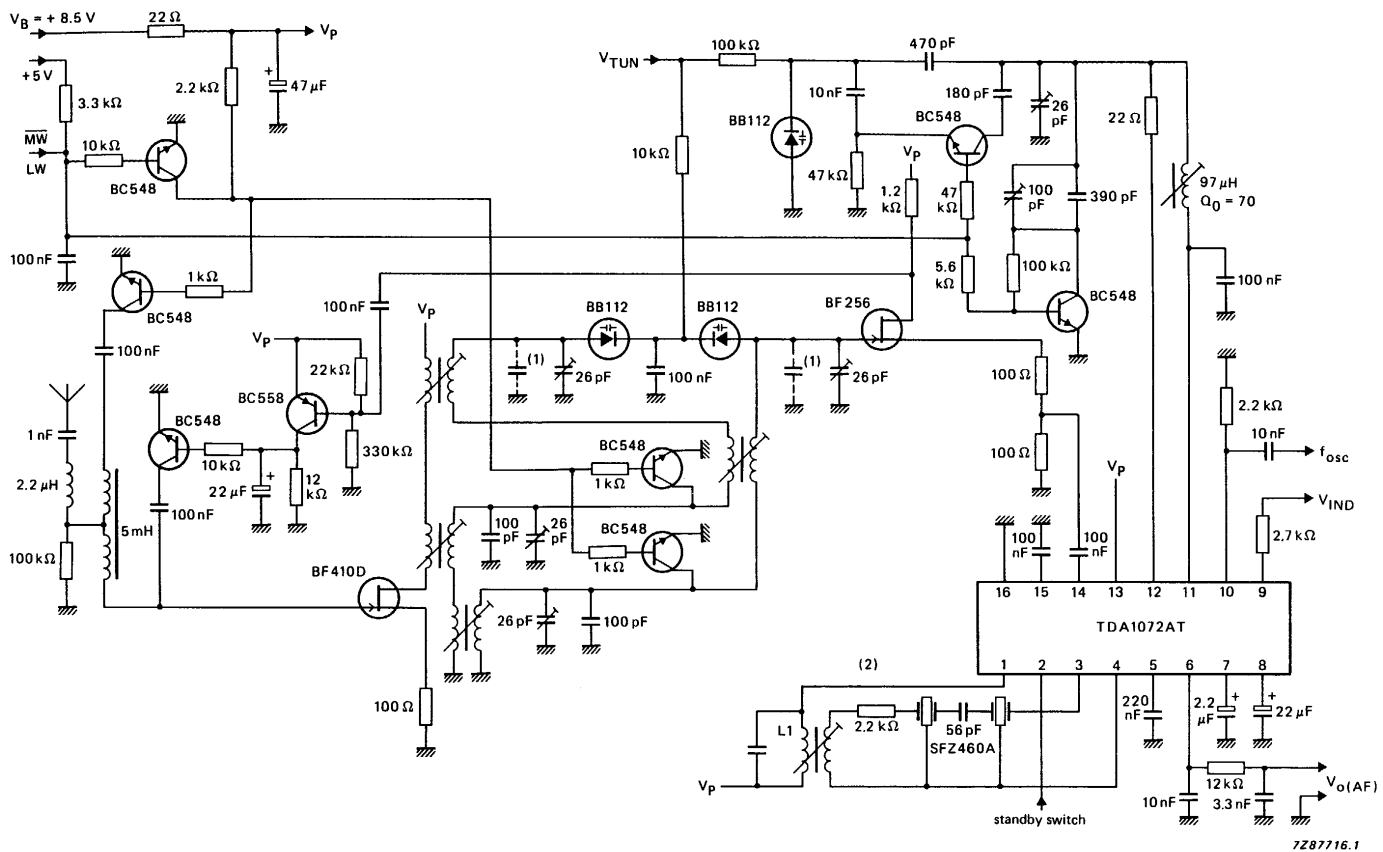

(1) Values of capacitors depend on the selected group of capacitive diodes BB112.
 (2) For IF filter and coil data refer to Fig.1.

Fig.16 Car radio application with capacitive diode tuning and electronic MW/LW switching. The circuit includes pre-stage AGC optimised for good large-signal handling.

7287716.1

AM receiver circuit

TDA1072AT

PACKAGE OUTLINE

SO16: plastic small outline package; 16 leads; body width 3.9 mm

SOT109-1

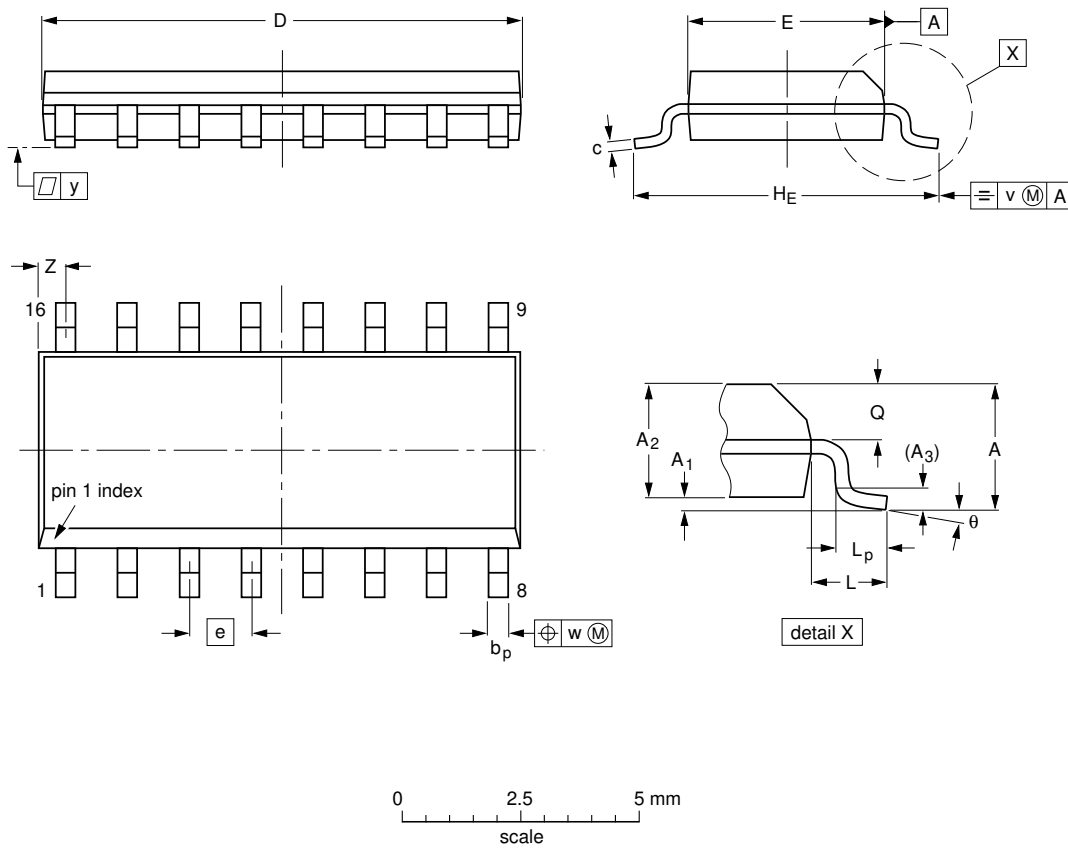

DIMENSIONS (inch dimensions are derived from the original mm dimensions)

UNIT	A max.	A ₁	A ₂	A ₃	b _p	c	D ⁽¹⁾	E ⁽¹⁾	e	H _E	L	L _p	Q	v	w	y	Z ⁽¹⁾	θ
mm	1.75	0.25 0.10	1.45 1.25	0.25	0.49 0.36	0.25 0.19	10.0 9.8	4.0 3.8	1.27	6.2 5.8	1.05	1.0 0.4	0.7 0.6	0.25	0.25	0.1	0.7 0.3	8° 0°
inches	0.069	0.0098 0.0039	0.057 0.049	0.01	0.019 0.014	0.0098 0.0075	0.39 0.38	0.16 0.15	0.050	0.24 0.23	0.041	0.039 0.016	0.028 0.020	0.01	0.01	0.004	0.028 0.012	

Note

1. Plastic or metal protrusions of 0.15 mm maximum per side are not included.

OUTLINE VERSION	REFERENCES				EUROPEAN PROJECTION	ISSUE DATE
	IEC	JEDEC	EIAJ			
SOT109-1	076E07S	MS-012AC				91-08-13 95-01-23

AM receiver circuit

TDA1072AT

SOLDERING

Introduction

There is no soldering method that is ideal for all IC packages. Wave soldering is often preferred when through-hole and surface mounted components are mixed on one printed-circuit board. However, wave soldering is not always suitable for surface mounted ICs, or for printed-circuits with high population densities. In these situations reflow soldering is often used.

This text gives a very brief insight to a complex technology. A more in-depth account of soldering ICs can be found in our *"IC Package Databook"* (order code 9398 652 90011).

Reflow soldering

Reflow soldering techniques are suitable for all SO packages.

Reflow soldering requires solder paste (a suspension of fine solder particles, flux and binding agent) to be applied to the printed-circuit board by screen printing, stencilling or pressure-syringe dispensing before package placement.

Several techniques exist for reflowing; for example, thermal conduction by heated belt. Dwell times vary between 50 and 300 seconds depending on heating method. Typical reflow temperatures range from 215 to 250 °C.

Preheating is necessary to dry the paste and evaporate the binding agent. Preheating duration: 45 minutes at 45 °C.

Wave soldering

Wave soldering techniques can be used for all SO packages if the following conditions are observed:

- A double-wave (a turbulent wave with high upward pressure followed by a smooth laminar wave) soldering technique should be used.
- The longitudinal axis of the package footprint must be parallel to the solder flow.
- The package footprint must incorporate solder thieves at the downstream end.

During placement and before soldering, the package must be fixed with a droplet of adhesive. The adhesive can be applied by screen printing, pin transfer or syringe dispensing. The package can be soldered after the adhesive is cured.

Maximum permissible solder temperature is 260 °C, and maximum duration of package immersion in solder is 10 seconds, if cooled to less than 150 °C within 6 seconds. Typical dwell time is 4 seconds at 250 °C.

A mildly-activated flux will eliminate the need for removal of corrosive residues in most applications.

Repairing soldered joints

Fix the component by first soldering two diagonally-opposite end leads. Use only a low voltage soldering iron (less than 24 V) applied to the flat part of the lead. Contact time must be limited to 10 seconds at up to 300 °C. When using a dedicated tool, all other leads can be soldered in one operation within 2 to 5 seconds between 270 and 320 °C.

AM receiver circuit

TDA1072AT

DEFINITIONS

Data sheet status	
Objective specification	This data sheet contains target or goal specifications for product development.
Preliminary specification	This data sheet contains preliminary data; supplementary data may be published later.
Product specification	This data sheet contains final product specifications.
Limiting values	
Limiting values given are in accordance with the Absolute Maximum Rating System (IEC 134). Stress above one or more of the limiting values may cause permanent damage to the device. These are stress ratings only and operation of the device at these or at any other conditions above those given in the Characteristics sections of the specification is not implied. Exposure to limiting values for extended periods may affect device reliability.	
Application information	
Where application information is given, it is advisory and does not form part of the specification.	

LIFE SUPPORT APPLICATIONS

These products are not designed for use in life support appliances, devices, or systems where malfunction of these products can reasonably be expected to result in personal injury. Philips customers using or selling these products for use in such applications do so at their own risk and agree to fully indemnify Philips for any damages resulting from such improper use or sale.