



Chipsmall Limited consists of a professional team with an average of over 10 year of expertise in the distribution of electronic components. Based in Hongkong, we have already established firm and mutual-benefit business relationships with customers from,Europe,America and south Asia,supplying obsolete and hard-to-find components to meet their specific needs.

With the principle of “Quality Parts,Customers Priority,Honest Operation,and Considerate Service”,our business mainly focus on the distribution of electronic components. Line cards we deal with include Microchip,ALPS,ROHM,Xilinx,Pulse,ON,Everlight and Freescale. Main products comprise IC,Modules,Potentiometer,IC Socket,Relay,Connector.Our parts cover such applications as commercial,industrial, and automotives areas.

We are looking forward to setting up business relationship with you and hope to provide you with the best service and solution. Let us make a better world for our industry!



## Contact us

Tel: +86-755-8981 8866 Fax: +86-755-8427 6832

Email & Skype: info@chipsmall.com Web: www.chipsmall.com

Address: A1208, Overseas Decoration Building, #122 Zhenhua RD., Futian, Shenzhen, China



# DATA SHEET

## **TDA1517; TDA1517P** **2 x 6 W stereo power amplifier**

Product specification  
Supersedes data of 2002 Jan 17

2004 Feb 18



**2 x 6 W stereo power amplifier****TDA1517; TDA1517P****FEATURES**

- Requires very few external components
- High output power
- Fixed gain
- Good ripple rejection
- Mute/standby switch
- AC and DC short-circuit safe to ground and  $V_P$
- Thermally protected
- Reverse polarity safe
- Capability to handle high energy on outputs ( $V_P = 0$  V)
- No switch-on/switch-off plop
- Electrostatic discharge protection.

**GENERAL DESCRIPTION**

The TDA1517 is an integrated class-B dual output amplifier in a plastic single in-line medium power package with fin (SIL9MPF), a plastic rectangular-bent single in-line medium power package with fin (RBS9MPF) or a plastic heat-dissipating dual in-line package (HDIP18). The device is primarily developed for multi-media applications.

**QUICK REFERENCE DATA**

SYMBOL	PARAMETER	CONDITIONS	MIN.	TYP.	MAX.	UNIT
$V_P$	supply voltage		6.0	14.4	18.0	V
$I_{ORM}$	repetitive peak output current		–	–	2.5	A
$I_{q(tot)}$	total quiescent current		–	40	80	mA
$I_{sb}$	standby current		–	0.1	100	$\mu$ A
$I_{sw}$	switch-on current		–	–	40	$\mu$ A
$ Z_i $	input impedance		50	–	–	k $\Omega$
$P_o$	output power	$R_L = 4 \Omega$ ; THD = 0.5%	–	5	–	W
		$R_L = 4 \Omega$ ; THD = 10%	–	6	–	W
SVRR	supply voltage ripple rejection	$f_i = 100$ Hz to 10 kHz	48	–	–	dB
$\alpha_{CS}$	channel separation		40	–	–	dB
$G_v$	closed loop voltage gain		19	20	21	dB
$V_{no(rms)}$	noise output voltage (RMS value)		–	50	–	$\mu$ V
$T_c$	crystal temperature		–	–	150	$^{\circ}$ C

**ORDERING INFORMATION**

TYPE NUMBER	PACKAGE		
	NAME	DESCRIPTION	VERSION
TDA1517/N3	SIL9MPF	plastic single in-line medium power package with fin; 9 leads	SOT110-1
TDA1517/N3/S5	RBS9MPF	plastic rectangular-bent single in-line medium power package with fin; 9 leads	SOT352-1
TDA1517P	HDIP18	plastic heat-dissipating dual in-line package; 18 leads	SOT398-1

2 x 6 W stereo power amplifier

TDA1517; TDA1517P

BLOCK DIAGRAM

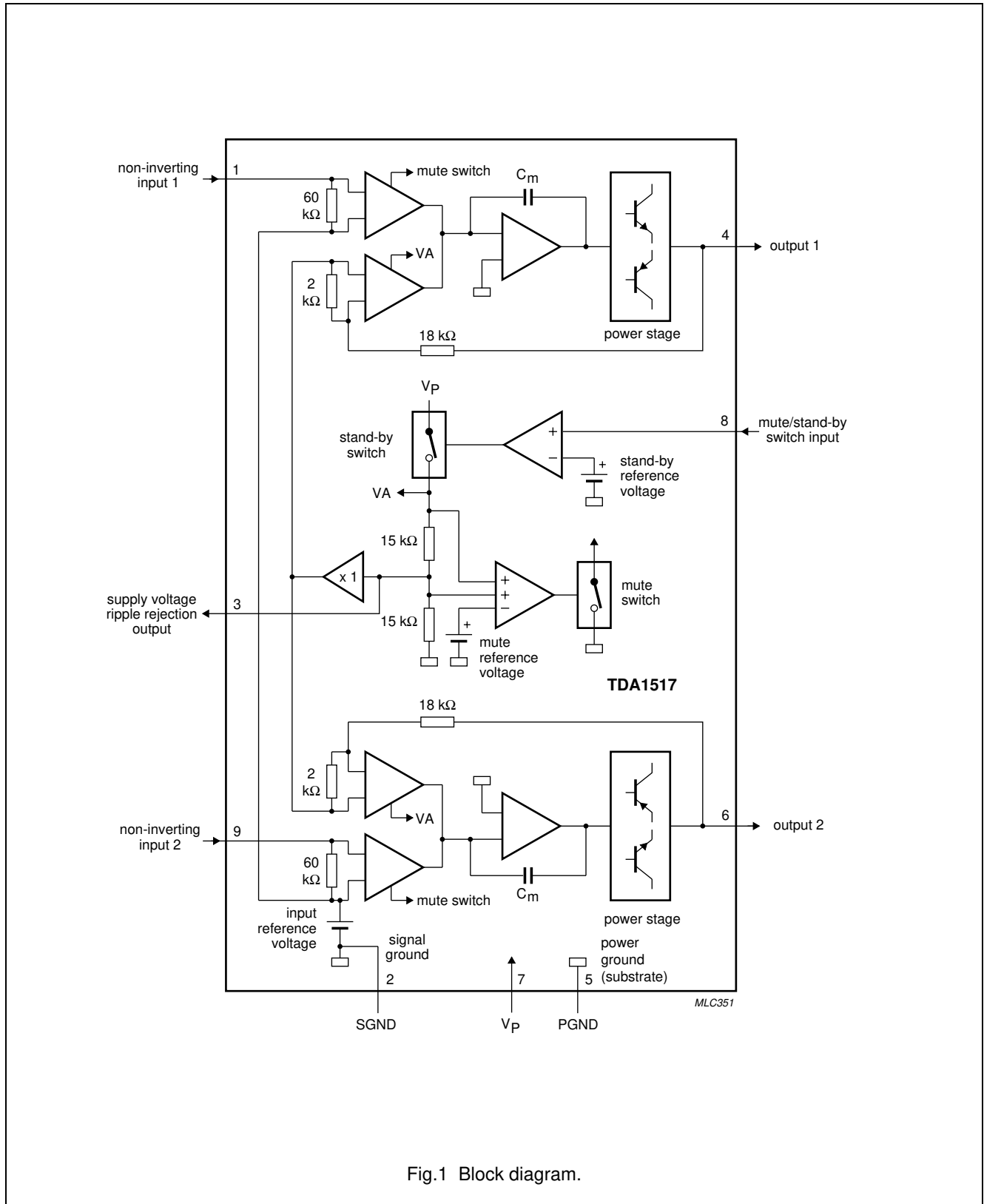

Fig.1 Block diagram.

2 x 6 W stereo power amplifier

TDA1517; TDA1517P

**PINNING**

SYMBOL	PIN	DESCRIPTION
-INV1	1	non-inverting input 1
SGND	2	signal ground
SVRR	3	supply voltage ripple rejection output
OUT1	4	output 1
PGND	5	power ground
OUT2	6	output 2
V <sub>P</sub>	7	supply voltage
M/SS	8	mute/standby switch input
-INV2	9	non-inverting input 2

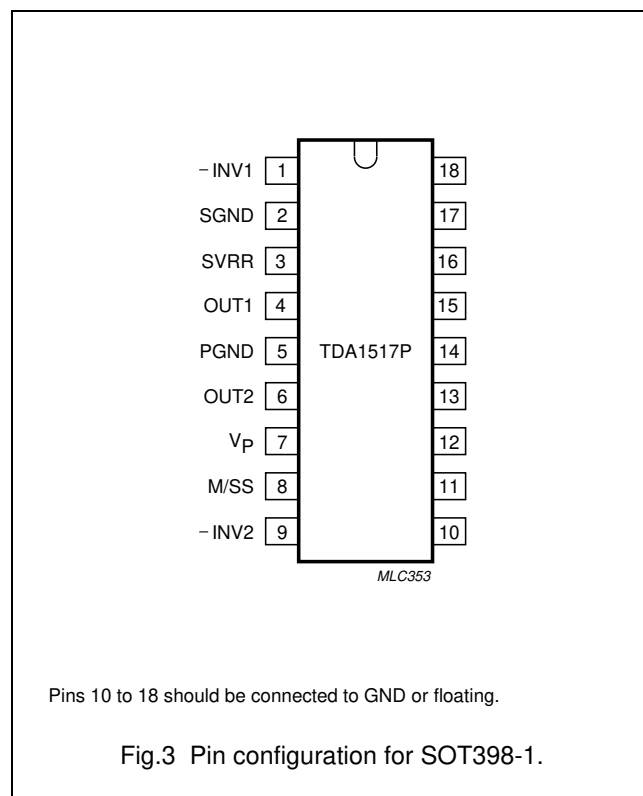
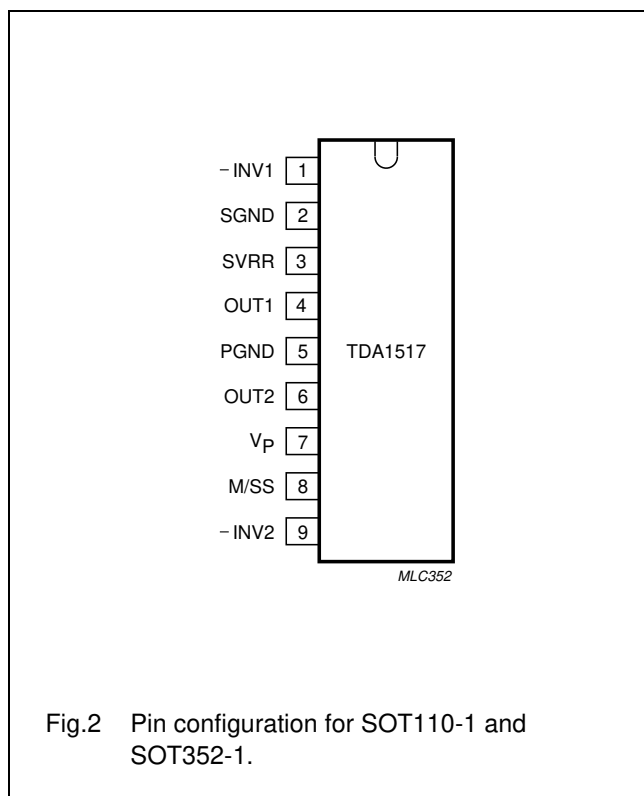

**FUNCTIONAL DESCRIPTION**

The TDA1517 contains two identical amplifiers with differential input stages. The gain of each amplifier is fixed at 20 dB. A special feature of the device is the mute/standby switch which has the following features:

- Low standby current (<100 μA)
- Low mute/standby switching current (low cost supply switch)
- Mute condition.

2 x 6 W stereo power amplifier

TDA1517; TDA1517P

**LIMITING VALUES**

In accordance with the Absolute Maximum Rating System (IEC 60134).

SYMBOL	PARAMETER	CONDITIONS	MIN.	MAX.	UNIT
V <sub>P</sub>	supply voltage	operating	–	18	V
		no signal	–	20	V
V <sub>P(sc)</sub>	AC and DC short-circuit safe voltage		–	18	V
V <sub>P(r)</sub>	reverse polarity		–	6	V
ERG <sub>O</sub>	energy handling capability at outputs	V <sub>P</sub> = 0 V	–	200	mJ
I <sub>OSM</sub>	non-repetitive peak output current		–	4	A
I <sub>ORM</sub>	repetitive peak output current		–	2.5	A
P <sub>tot</sub>	total power dissipation	see Fig.4	–	15	W
T <sub>stg</sub>	storage temperature		–55	+150	°C
T <sub>amb</sub>	operating ambient temperature		–40	+85	°C
T <sub>c</sub>	crystal temperature		–	150	°C

**THERMAL RESISTANCE**

SYMBOL	TYPE NUMBER	PARAMETER	VALUE	UNIT
R <sub>th(j-c)</sub>	TDA1517/N3; TDA1517/N3/S5	thermal resistance from junction to case	8	K/W
R <sub>th(j-p)</sub>	TDA1517P	thermal resistance from junction to pins	15	K/W
R <sub>th(j-a)</sub>	TDA1517/N3; TDA1517/N3/S5; TDA1517P	thermal resistance from junction to ambient	50	K/W

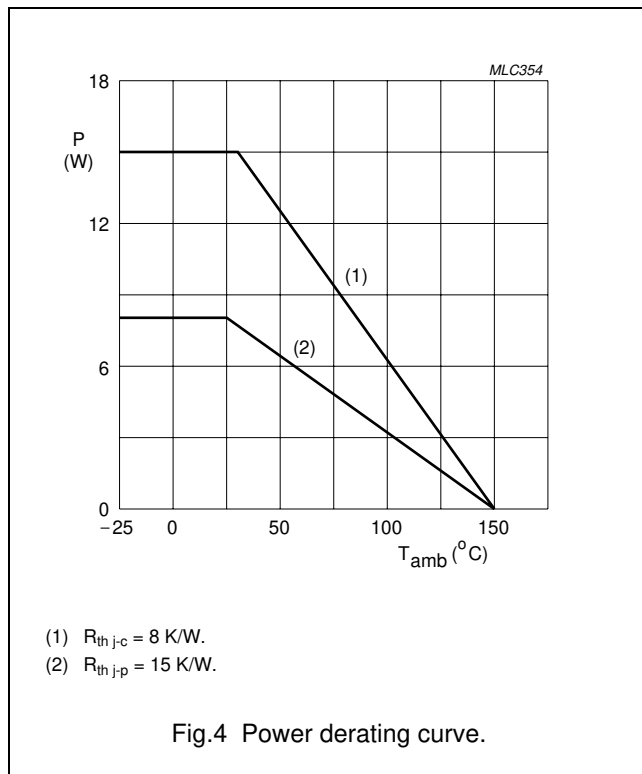

## 2 x 6 W stereo power amplifier

## TDA1517; TDA1517P

**DC CHARACTERISTICS**

$V_P = 14.4$  V;  $T_{amb} = 25$  °C; measured in Fig.6; unless otherwise specified.

SYMBOL	PARAMETER	CONDITIONS	MIN.	TYP.	MAX.	UNIT
<b>Supply</b>						
$V_P$	supply voltage	note 1	6.0	14.4	18.0	V
$I_{q(tot)}$	total quiescent current		–	40	80	mA
$V_O$	DC output voltage		–	6.95	–	V
<b>Mute/standby switch</b>						
$V_8$	switch-on voltage level	see Fig.5	8.5	–	–	V
<b>Mute condition</b>						
$V_O$	output signal in mute position	$V_{l(max)} = 1$ V; $f_i = 20$ Hz to 15 kHz	–	–	2	mV
<b>Standby condition</b>						
$I_{sb}$	DC current in standby condition		–	–	100	μA
$V_{sw}$	switch-on current		–	12	40	μA

**Note**

1. The circuit is DC adjusted at  $V_P = 6$  to 18 V and AC operating at  $V_P = 8.5$  to 18 V.

## 2 x 6 W stereo power amplifier

## TDA1517; TDA1517P

**AC CHARACTERISTICS**

$V_P = 14.4\text{ V}$ ;  $R_L = 4\ \Omega$ ;  $f = 1\text{ kHz}$ ;  $T_{\text{amb}} = 25\text{ }^\circ\text{C}$ ; measured in Fig.6; unless otherwise specified.

SYMBOL	PARAMETER	CONDITIONS	MIN.	TYP.	MAX.	UNIT
$P_o$	output power	THD = 0.5%; note 1	4	5	–	W
		THD = 10%; note 1	5.5	6.0	–	W
THD	total harmonic distortion	$P_o = 1\text{ W}$	–	0.1	–	%
$f_{lr}$	low frequency roll-off	at –3 dB; note 2	–	45	–	Hz
$f_{hr}$	high frequency roll-off	at –1 dB	20	–	–	kHz
$G_v$	closed loop voltage gain		19	20	21	dB
SVRR	supply voltage ripple rejection	note 3				
	on		48	–	–	dB
	mute		48	–	–	dB
	standby		80	–	–	dB
$ Z_i $	input impedance		50	60	75	k $\Omega$
$V_{no}$	noise output voltage					
	on	$R_s = 0\ \Omega$ ; note 4	–	50	–	$\mu\text{V}$
	on	$R_s = 10\ \Omega$ ; note 4	–	70	100	$\mu\text{V}$
	mute	note 5	–	50	–	$\mu\text{V}$
$\alpha_{CS}$	channel separation	$R_s = 10\ \Omega$	40	–	–	dB
$ \Delta G_v $	channel unbalance		–	0.1	1	dB

**Notes**

- Output power is measured directly at the output pins of the IC.
- Frequency response externally fixed.
- Ripple rejection measured at the output with a source impedance of  $0\ \Omega$ , maximum ripple amplitude of 2 V (p-p) and a frequency between 100 Hz and 10 kHz.
- Noise voltage measured in a bandwidth of 20 Hz to 20 kHz.
- Noise output voltage independent of  $R_s$  ( $V_i = 0\text{ V}$ ).



2 x 6 W stereo power amplifier

TDA1517; TDA1517P

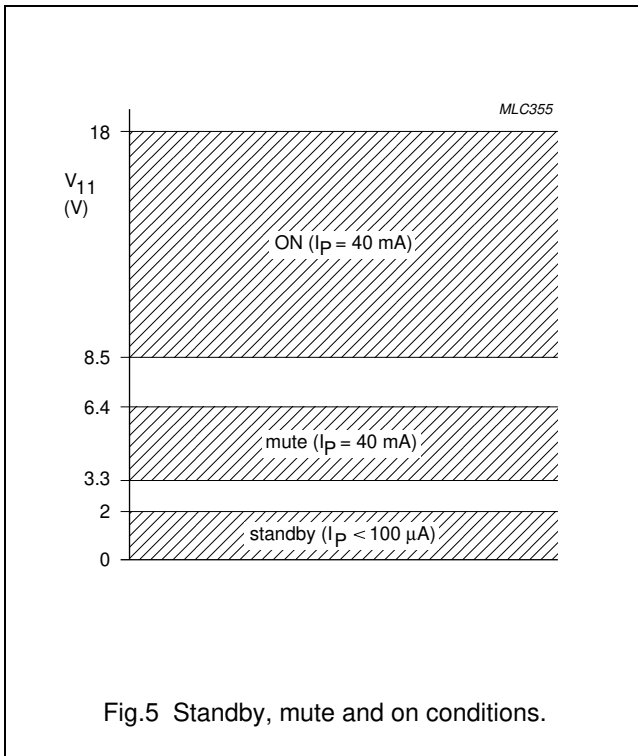

Fig.5 Standby, mute and on conditions.

APPLICATION INFORMATION

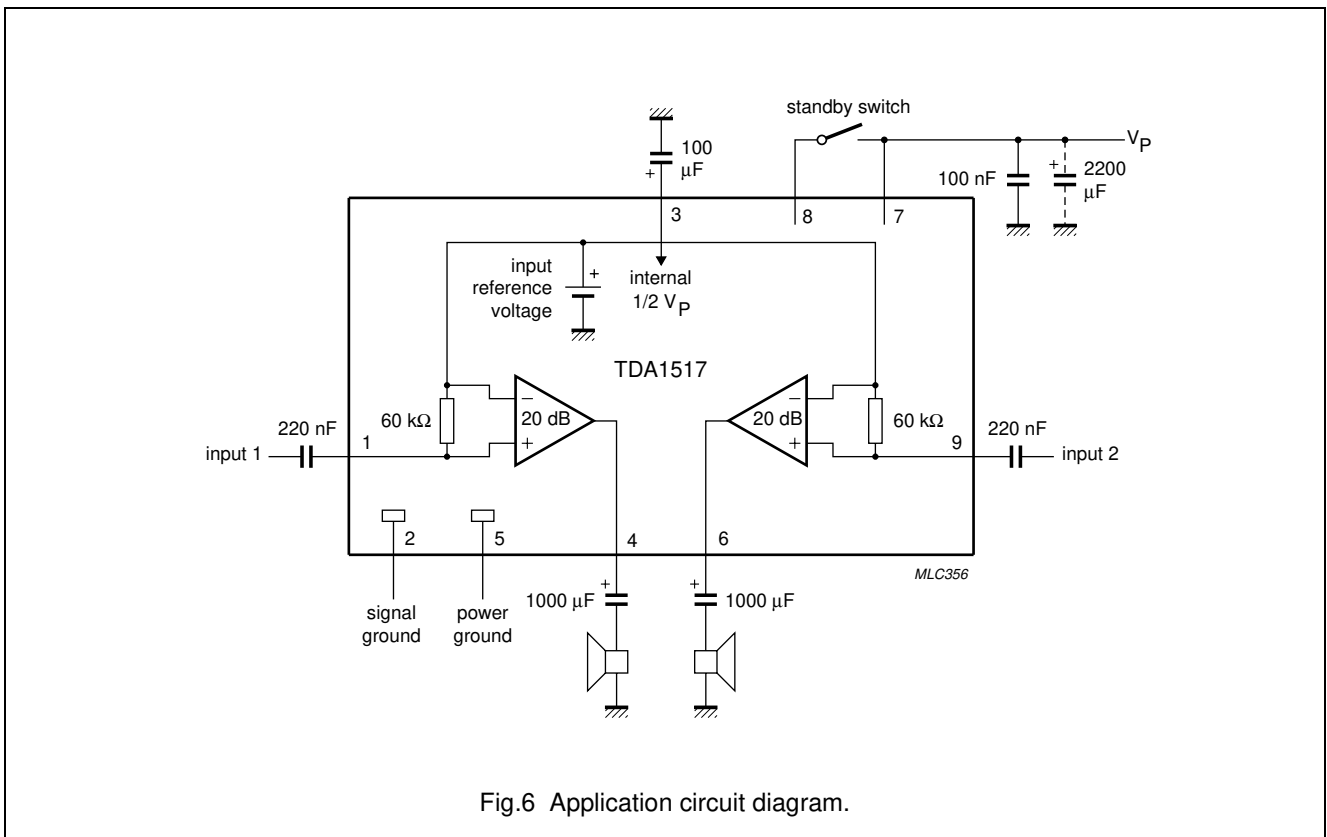

Fig.6 Application circuit diagram.

2 x 6 W stereo power amplifier

TDA1517; TDA1517P

PACKAGE OUTLINES

SIL9MPF: plastic single in-line medium power package with fin; 9 leads

SOT110-1

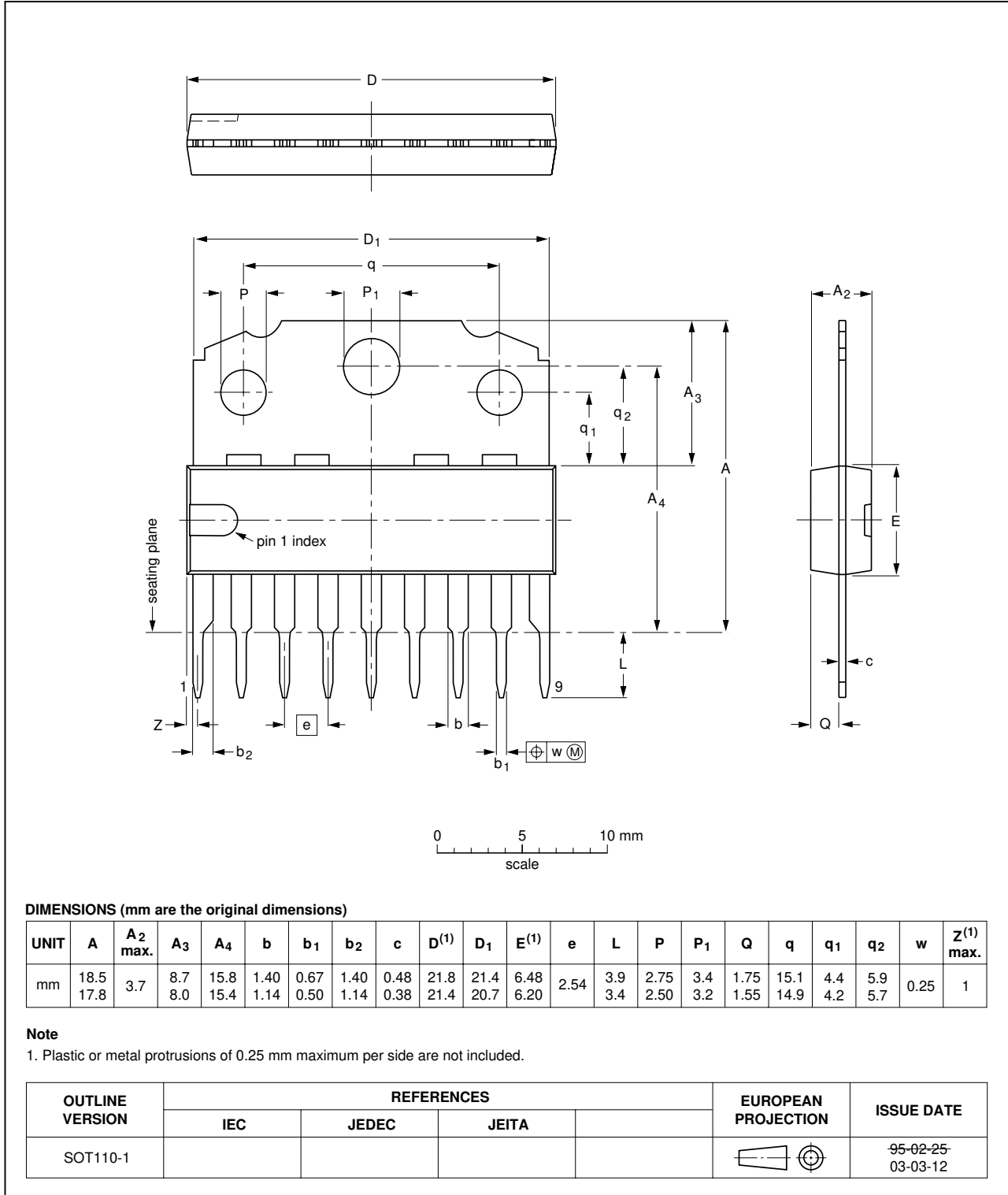

2 x 6 W stereo power amplifier

TDA1517; TDA1517P

RBS9MPF: plastic rectangular-bent single in-line medium power package with fin; 9 leads

SOT352-1

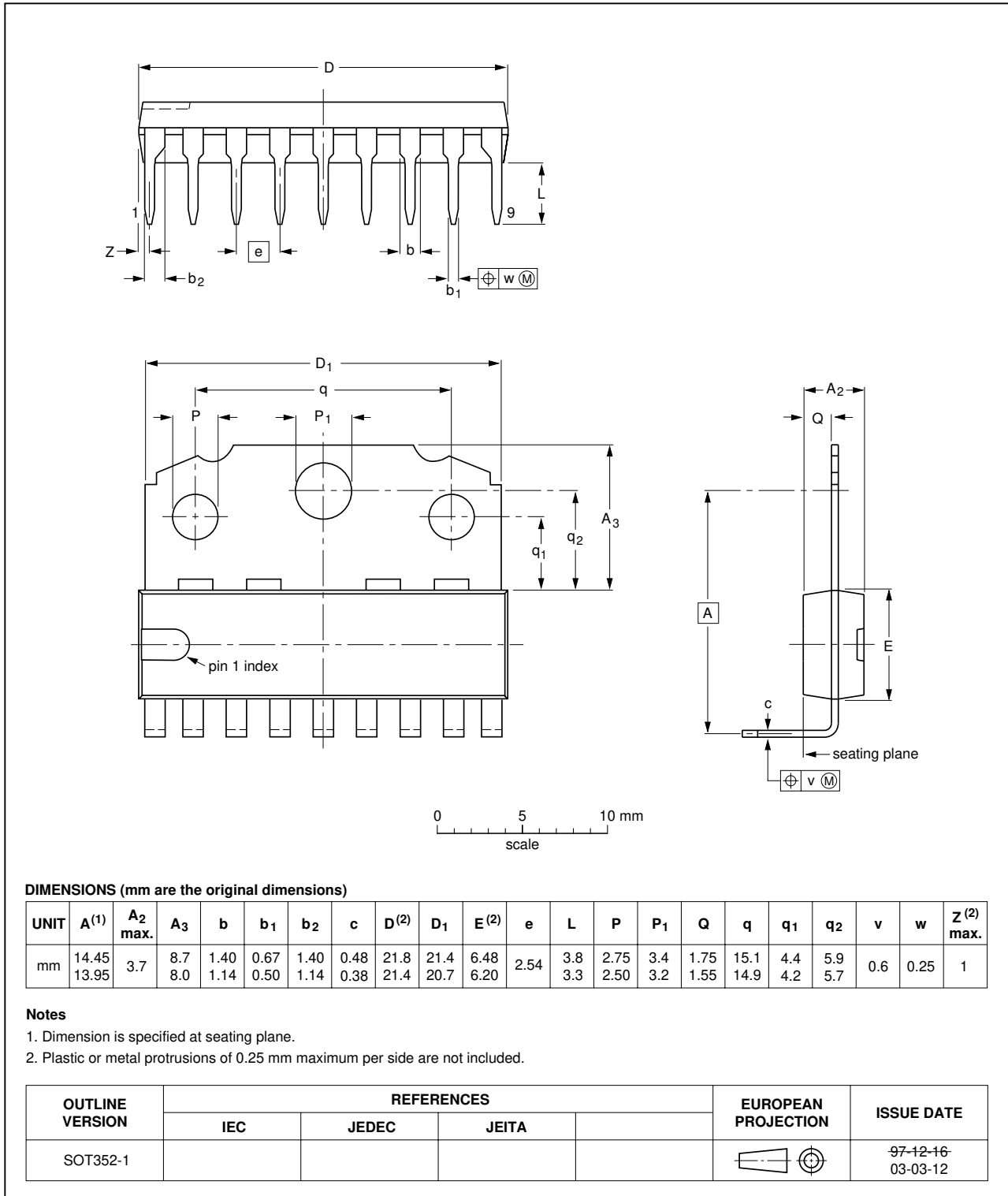

2 x 6 W stereo power amplifier

TDA1517; TDA1517P

HDIP18: plastic heat-dissipating dual in-line package; 18 leads

SOT398-1

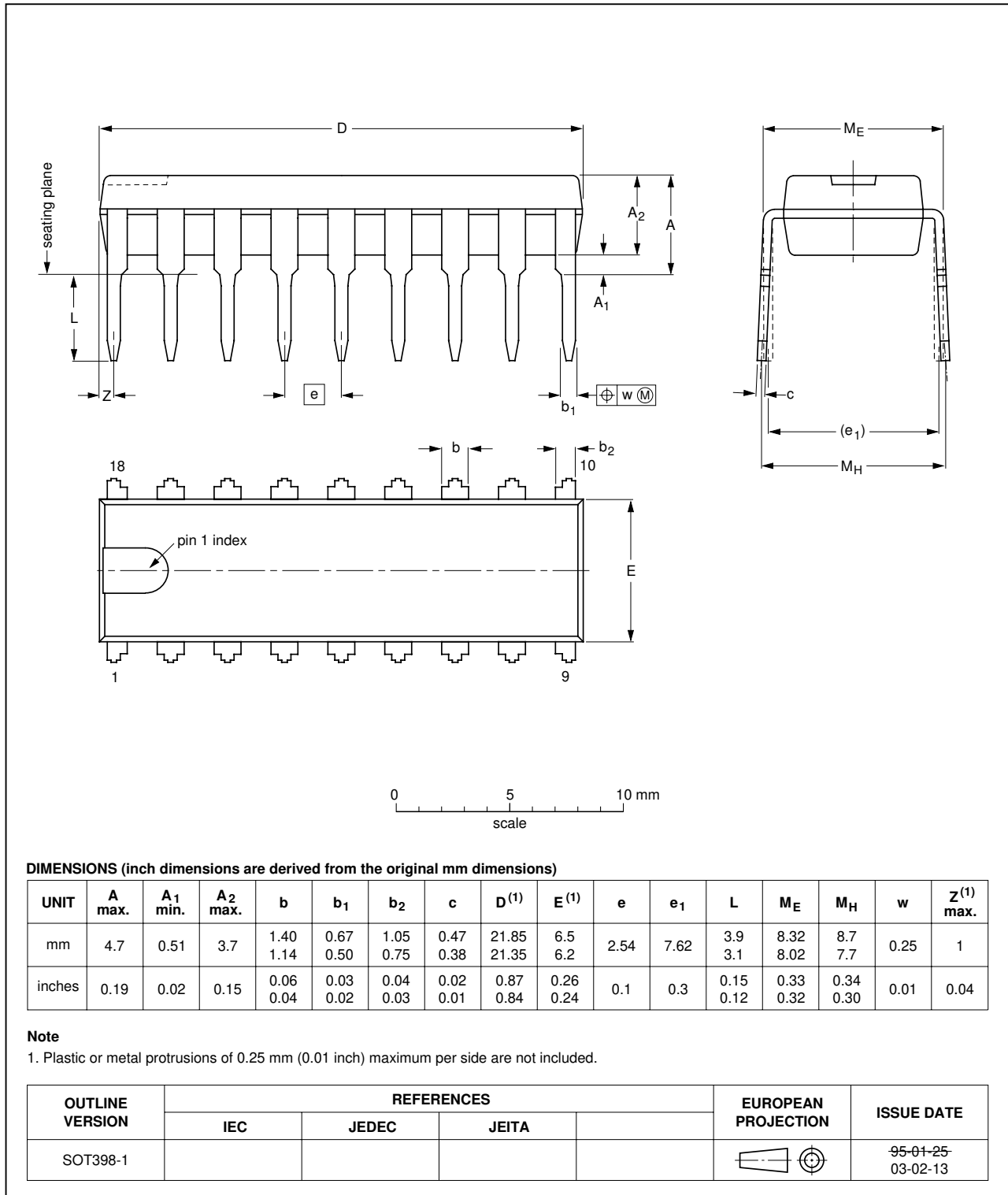

2 x 6 W stereo power amplifier

TDA1517; TDA1517P

**SOLDERING**

**Introduction to soldering through-hole mount packages**

This text gives a brief insight to wave, dip and manual soldering. A more in-depth account of soldering ICs can be found in our “*Data Handbook IC26; Integrated Circuit Packages*” (document order number 9398 652 90011).

Wave soldering is the preferred method for mounting of through-hole mount IC packages on a printed-circuit board.

**Soldering by dipping or by solder wave**

Driven by legislation and environmental forces the worldwide use of lead-free solder pastes is increasing. Typical dwell time of the leads in the wave ranges from 3 to 4 seconds at 250 °C or 265 °C, depending on solder material applied, SnPb or Pb-free respectively.

The total contact time of successive solder waves must not exceed 5 seconds.

The device may be mounted up to the seating plane, but the temperature of the plastic body must not exceed the specified maximum storage temperature ( $T_{stg(max)}$ ). If the printed-circuit board has been pre-heated, forced cooling may be necessary immediately after soldering to keep the temperature within the permissible limit.

**Manual soldering**

Apply the soldering iron (24 V or less) to the lead(s) of the package, either below the seating plane or not more than 2 mm above it. If the temperature of the soldering iron bit is less than 300 °C it may remain in contact for up to 10 seconds. If the bit temperature is between 300 and 400 °C, contact may be up to 5 seconds.

**Suitability of through-hole mount IC packages for dipping and wave soldering methods**

PACKAGE	SOLDERING METHOD	
	DIPPING	WAVE
CPGA, HCPGA	–	suitable
DBS, DIP, HDIP, RDBS, SDIP, SIL	suitable	suitable <sup>(1)</sup>
PMFP <sup>(2)</sup>	–	not suitable

**Notes**

1. For SDIP packages, the longitudinal axis must be parallel to the transport direction of the printed-circuit board.
2. For PMFP packages hot bar soldering or manual soldering is suitable.

## 2 x 6 W stereo power amplifier

## TDA1517; TDA1517P

## DATA SHEET STATUS

DOCUMENT STATUS <sup>(1)</sup>	PRODUCT STATUS <sup>(2)</sup>	DEFINITION
Objective data sheet	Development	This document contains data from the objective specification for product development.
Preliminary data sheet	Qualification	This document contains data from the preliminary specification.
Product data sheet	Production	This document contains the product specification.

## Notes

1. Please consult the most recently issued document before initiating or completing a design.
2. The product status of device(s) described in this document may have changed since this document was published and may differ in case of multiple devices. The latest product status information is available on the Internet at URL <http://www.nxp.com>.

## DISCLAIMERS

**Limited warranty and liability** — Information in this document is believed to be accurate and reliable. However, NXP Semiconductors does not give any representations or warranties, expressed or implied, as to the accuracy or completeness of such information and shall have no liability for the consequences of use of such information.

In no event shall NXP Semiconductors be liable for any indirect, incidental, punitive, special or consequential damages (including - without limitation - lost profits, lost savings, business interruption, costs related to the removal or replacement of any products or rework charges) whether or not such damages are based on tort (including negligence), warranty, breach of contract or any other legal theory.

Notwithstanding any damages that customer might incur for any reason whatsoever, NXP Semiconductors' aggregate and cumulative liability towards customer for the products described herein shall be limited in accordance with the *Terms and conditions of commercial sale* of NXP Semiconductors.

**Right to make changes** — NXP Semiconductors reserves the right to make changes to information published in this document, including without limitation specifications and product descriptions, at any time and without notice. This document supersedes and replaces all information supplied prior to the publication hereof.

**Suitability for use** — NXP Semiconductors products are not designed, authorized or warranted to be suitable for use in life support, life-critical or safety-critical systems or equipment, nor in applications where failure or malfunction of an NXP Semiconductors product can reasonably be expected to result in personal injury, death or severe

property or environmental damage. NXP Semiconductors accepts no liability for inclusion and/or use of NXP Semiconductors products in such equipment or applications and therefore such inclusion and/or use is at the customer's own risk.

**Applications** — Applications that are described herein for any of these products are for illustrative purposes only. NXP Semiconductors makes no representation or warranty that such applications will be suitable for the specified use without further testing or modification.

Customers are responsible for the design and operation of their applications and products using NXP Semiconductors products, and NXP Semiconductors accepts no liability for any assistance with applications or customer product design. It is customer's sole responsibility to determine whether the NXP Semiconductors product is suitable and fit for the customer's applications and products planned, as well as for the planned application and use of customer's third party customer(s). Customers should provide appropriate design and operating safeguards to minimize the risks associated with their applications and products.

NXP Semiconductors does not accept any liability related to any default, damage, costs or problem which is based on any weakness or default in the customer's applications or products, or the application or use by customer's third party customer(s). Customer is responsible for doing all necessary testing for the customer's applications and products using NXP Semiconductors products in order to avoid a default of the applications and the products or of the application or use by customer's third party customer(s). NXP does not accept any liability in this respect.

---

## 2 x 6 W stereo power amplifier

## TDA1517; TDA1517P

---

**Limiting values** — Stress above one or more limiting values (as defined in the Absolute Maximum Ratings System of IEC 60134) will cause permanent damage to the device. Limiting values are stress ratings only and (proper) operation of the device at these or any other conditions above those given in the Recommended operating conditions section (if present) or the Characteristics sections of this document is not warranted. Constant or repeated exposure to limiting values will permanently and irreversibly affect the quality and reliability of the device.

**Terms and conditions of commercial sale** — NXP Semiconductors products are sold subject to the general terms and conditions of commercial sale, as published at <http://www.nxp.com/profile/terms>, unless otherwise agreed in a valid written individual agreement. In case an individual agreement is concluded only the terms and conditions of the respective agreement shall apply. NXP Semiconductors hereby expressly objects to applying the customer's general terms and conditions with regard to the purchase of NXP Semiconductors products by customer.

**No offer to sell or license** — Nothing in this document may be interpreted or construed as an offer to sell products that is open for acceptance or the grant, conveyance or implication of any license under any copyrights, patents or other industrial or intellectual property rights.

**Export control** — This document as well as the item(s) described herein may be subject to export control regulations. Export might require a prior authorization from national authorities.

**Quick reference data** — The Quick reference data is an extract of the product data given in the Limiting values and Characteristics sections of this document, and as such is not complete, exhaustive or legally binding.

**Non-automotive qualified products** — Unless this data sheet expressly states that this specific NXP Semiconductors product is automotive qualified, the product is not suitable for automotive use. It is neither qualified nor tested in accordance with automotive testing or application requirements. NXP Semiconductors accepts no liability for inclusion and/or use of non-automotive qualified products in automotive equipment or applications.

In the event that customer uses the product for design-in and use in automotive applications to automotive specifications and standards, customer (a) shall use the product without NXP Semiconductors' warranty of the product for such automotive applications, use and specifications, and (b) whenever customer uses the product for automotive applications beyond NXP Semiconductors' specifications such use shall be solely at customer's own risk, and (c) customer fully indemnifies NXP Semiconductors for any liability, damages or failed product claims resulting from customer design and use of the product for automotive applications beyond NXP Semiconductors' standard warranty and NXP Semiconductors' product specifications.

# ***NXP Semiconductors***

***provides High Performance Mixed Signal and Standard Product solutions that leverage its leading RF, Analog, Power Management, Interface, Security and Digital Processing expertise***

## **Customer notification**

This data sheet was changed to reflect the new company name NXP Semiconductors. No changes were made to the content, except for the legal definitions and disclaimers.

## **Contact information**

For additional information please visit: **<http://www.nxp.com>**

For sales offices addresses send e-mail to: **[salesaddresses@nxp.com](mailto:salesaddresses@nxp.com)**

© NXP B.V. 2010

All rights are reserved. Reproduction in whole or in part is prohibited without the prior written consent of the copyright owner.

The information presented in this document does not form part of any quotation or contract, is believed to be accurate and reliable and may be changed without notice. No liability will be accepted by the publisher for any consequence of its use. Publication thereof does not convey nor imply any license under patent- or other industrial or intellectual property rights.

Printed in The Netherlands

R30/05/pp15

Date of release: 2004 Feb 18

Document order number: 9397 750 12926