



Chipsmall Limited consists of a professional team with an average of over 10 year of expertise in the distribution of electronic components. Based in Hongkong, we have already established firm and mutual-benefit business relationships with customers from,Europe,America and south Asia,supplying obsolete and hard-to-find components to meet their specific needs.

With the principle of “Quality Parts,Customers Priority,Honest Operation,and Considerate Service”,our business mainly focus on the distribution of electronic components. Line cards we deal with include Microchip,ALPS,ROHM,Xilinx,Pulse,ON,Everlight and Freescale. Main products comprise IC,Modules,Potentiometer,IC Socket,Relay,Connector.Our parts cover such applications as commercial,industrial, and automotives areas.

We are looking forward to setting up business relationship with you and hope to provide you with the best service and solution. Let us make a better world for our industry!



Contact us

Tel: +86-755-8981 8866 Fax: +86-755-8427 6832

Email & Skype: info@chipsmall.com Web: www.chipsmall.com

Address: A1208, Overseas Decoration Building, #122 Zhenhua RD., Futian, Shenzhen, China



DATA SHEET

TDA1575T

FM front end circuit for
CENELEC EN 55020 applications

Preliminary specification
Supersedes data of October 1990
File under Integrated Circuits, IC01

April 1993

FM front end circuit for CENELEC EN 55020 applications

TDA1575T

FEATURES

- Bipolar integrated FM front end circuit, designed for use in car radios and home receivers
- Fulfils CENELEC EN 55020 requirements
- Radio frequency range of 76 to 90 MHz (Japan) or 87.5 to 108 MHz (Europe, USA)
- Low noise oscillator, buffered oscillator output
- Double balanced mixer
- Internal buffered mixer driving
- Linear IF amplifier, suitable for ceramic IF filters
- Regulated reference voltage.

QUICK REFERENCE DATA

SYMBOL	PARAMETER	MIN.	TYP.	MAX.	UNIT
V_P	supply voltage	7	8.5	10	V
I_P	supply current, without mixer	–	23	–	mA
V_{REF}	reference voltage output	–	4.2	–	V
Z_I	mixer input impedance	–	14	–	Ω
NF	noise figure of mixer	–	9	–	dB
EMF1	3rd order intermodulation	–	115	–	$\text{dB}\mu\text{V}$
V_{OSC}	oscillator buffer output signal (RMS value)	75	–	–	mV
THD	total harmonic distortion	–	–15	–	dB
G_v	IF gain	–	30	–	dB
NF	IF noise figure	–	6.5	–	dB
Z_I	IF input impedance	–	300	–	Ω
Z_O	IF output impedance	–	300	–	Ω
EMF2	AGC wideband threshold (RMS value)	–	17	–	mV

ORDERING INFORMATION

EXTENDED TYPE NUMBER	PACKAGE			
	PINS	PIN POSITION	MATERIAL	CODE
TDA1575T	16	mini-pack	plastic	SOT109A ⁽¹⁾

Note

1. SOT109-1; 1996 August 29.

FM front end circuit for
CENELEC EN 55020 applications

TDA1575T

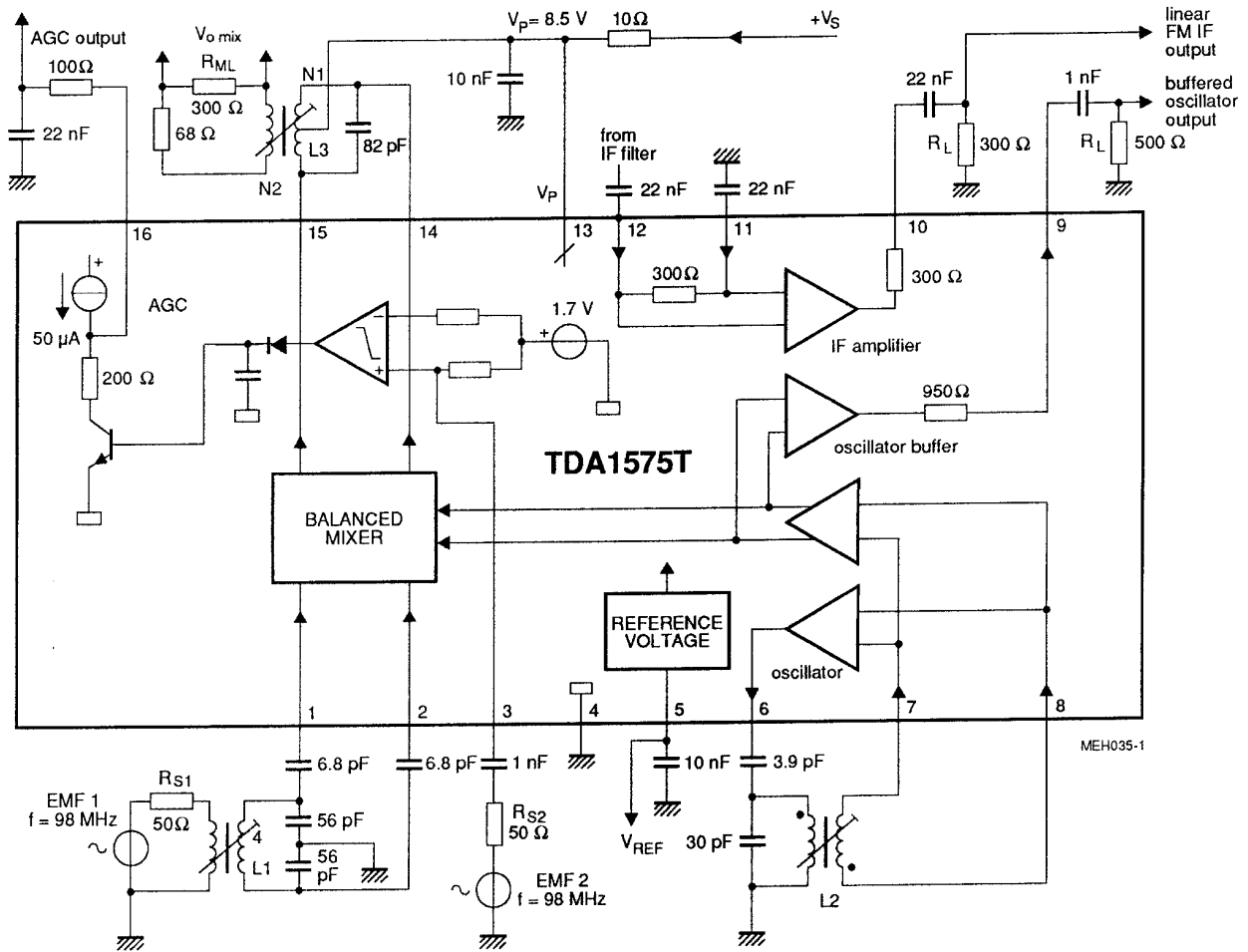

Coils TOKO
 L1: MC-108 514 HNE-150023S14; L = 78 nH, N = 4 turns
 L2: MC-111 E516 HNS-200057; L = 80 nH
 L3: A119 ACS-17114 FTT

Fig.1 Block diagram and test circuit.

FM front end circuit for CENELEC EN 55020 applications

TDA1575T

PINNING

SYMBOL	PIN	DESCRIPTION
MIXI1	1	RF input 1 to mixer
MIXI2	2	RF input 2 to mixer
AGCI	3	HF input to automatic gain control
GND	4	ground (0 V)
V _{REF}	5	reference voltage output
OSCO	6	oscillator output
OSCI1	7	oscillator input 1
OSCI2	8	oscillator input 2
LO	9	buffered oscillator output
IFO	10	linear FM IF output
IFI1	11	FM IF input 1
IFI2	12	FM IF input 2
V _P	13	supply voltage (+8.5 V)
MIXO1	14	mixer output 1
MIXO2	15	mixer output 2
AGCO	16	automatic gain control output

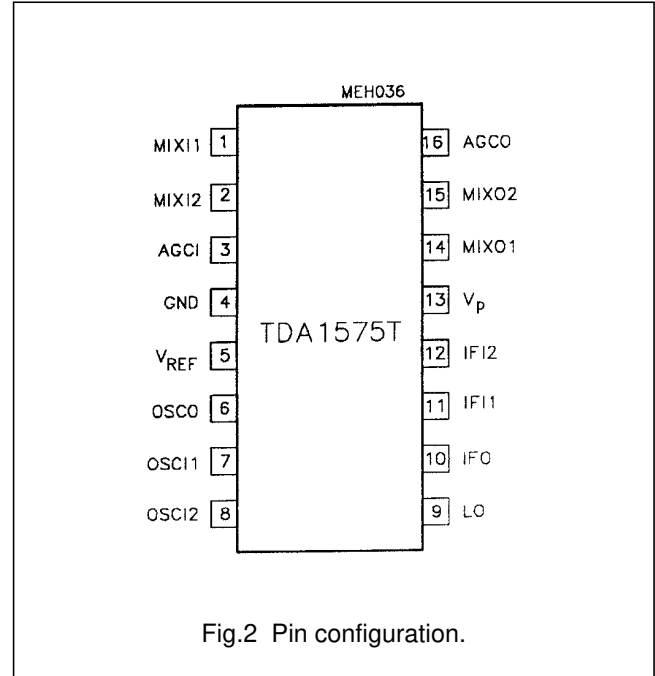

Fig.2 Pin configuration.

LIMITING VALUES

Limiting values in accordance with the Absolute Maximum System (IEC 134).

SYMBOL	PARAMETER	MIN.	MAX.	UNIT
V _P	supply voltage (pin 13)	0	12	V
V _{14, 15}	voltage at mixer output	0	V _P	V
P _{tot}	total power dissipation	0	380	mW
T _{stg}	storage temperature range	-55	+150	°C
T _{amb}	operating ambient temperature range	-40	+85	°C
V _{ESD}	electrostatic handling (see note 1)			
	all pins except 3 and 10	-	±2000	V
	pin 3	-	+2000	V
		-	-1000	V
	pin 10	-	+1500	V
		-	-2000	V

Note to the limiting values

1. Equivalent to discharging a 100 pF capacitor through a 1.5 kΩ series resistor.

FM front end circuit for CENELEC EN 55020 applications

TDA1575T

CHARACTERISTICS

$V_P = 8.5$ V and $T_{amb} = +25^\circ\text{C}$, measurements taken in Fig.1 with $f_0 = 98$ MHz (EMF1) unless otherwise specified.

SYMBOL	PARAMETER	CONDITIONS	MIN.	TYP.	MAX.	UNIT
V_P	supply voltage (pin 13)		7	8.5	10	V
I_P	supply current	without mixer	16	23	30	mA
V_{REF}	reference voltage (pin 5)	$I_5 \leq 3$ mA	3.9	4.2	4.4	V
Mixer						
I_{14+15}	mixer supply current (pins 14 and 15)		–	4	–	mA
$V_{1,2}$	DC voltage input (pins 1 and 2)		–	1	–	V
$Z_{1,2}$	input impedance		–	14	–	Ω
$V_{14,15}$	DC output voltage (pins 14 and 15)		4	–	10	V
$C_{14,15}$	output capacitance		–	13	–	pF
G_P	conversion power gain	note 1	–	14	–	dB
EMF1 _{IP3}	3rd order intercept point		–	115	–	dB μ V
NF	noise figure		–	9	–	dB
	total noise figure	including transforming network	–	11	–	dB
Oscillator						
$V_{7,8}$	DC input voltage (pins 7 and 8)		–	1.3	–	V
V_6	DC output voltage (pin 6)		–	2.0	–	V
Δf	residual FM at pin 6	$f = 300$ to 15000 Hz; de-emphasis $50 \mu\text{s}$	–	2.2	–	Hz
Oscillator buffered output (pin 9)						
V_O	output signal (RMS value)	$R_L = 500 \Omega$; $C_L = 2$ pF	75	–	–	mV
V_9	DC output voltage		–	6	–	V
R_9	DC output resistor		–	950	–	Ω
THD	total harmonic distortion		–	–15	–	dB
f_S	spurious frequencies	EMF1 = 2 V; $R_S = 50 \Omega$; $f_{OSC} = 108.7$ MHz	–	–37	–	dB
Automatic gain control (AGC)						
R_3	input resistance (pin 3)		–	4	–	k Ω
C_3	input capacitance		–	3	–	pF
V_{16}	AGC output swing (DC)	Figs 3 and 4	0.5	–	$V_P - 0.3$	V
I_{16}	output current at $I_3 = 0$	$V_{16} = \frac{1}{2}V_P$	–25	–50	–150	μA
	output current at $U_3 = 2$ V	$V_{16} = 7$ to 10 V	2	–	5	mA
EMF2	threshold (RMS value)	$I_{16} = 0$; $V_{16} = \frac{1}{2}V_P$; Figs 4 and 5	–	17	–	mV

FM front end circuit for
CENELEC EN 55020 applications

TDA1575T

SYMBOL	PARAMETER	CONDITIONS	MIN.	TYP.	MAX.	UNIT
Linear IF amplifier		IF = 10.7 MHz				
V _{11,12}	DC input voltage (pins 11 and 12)		–	1.25	–	V
Z ₁₂₋₁₁	input impedance		240	300	360	Ω
C ₁₂₋₁₁	input capacitance		–	13	–	pF
V ₁₀	DC output voltage (pin 10)		–	4.4	–	V
Z ₁₀	output impedance		240	300	360	Ω
C ₁₀	output capacitance		–	3	–	pF
V _O	output signal (RMS value)	–1 dB compression	–	–	650	mV
G _V	IF voltage gain (20 log (V ₁₀₋₄ / V ₁₂₋₁₁))		27	30	–	dB
ΔG _V	IF voltage gain deviation	T _{amb} = –40 to +85 °C	–	0	–	dB
NF	noise figure	R _S = 300 Ω	–	6.5	–	dB

Note

1. $G_p = 10 \log (4V_{o\text{ mix}} \times 10.7 \text{ MHz}) / (\text{EMF2} \times 98 \text{ MHz})^2 \times (R_{S1} / R_{ML})$.

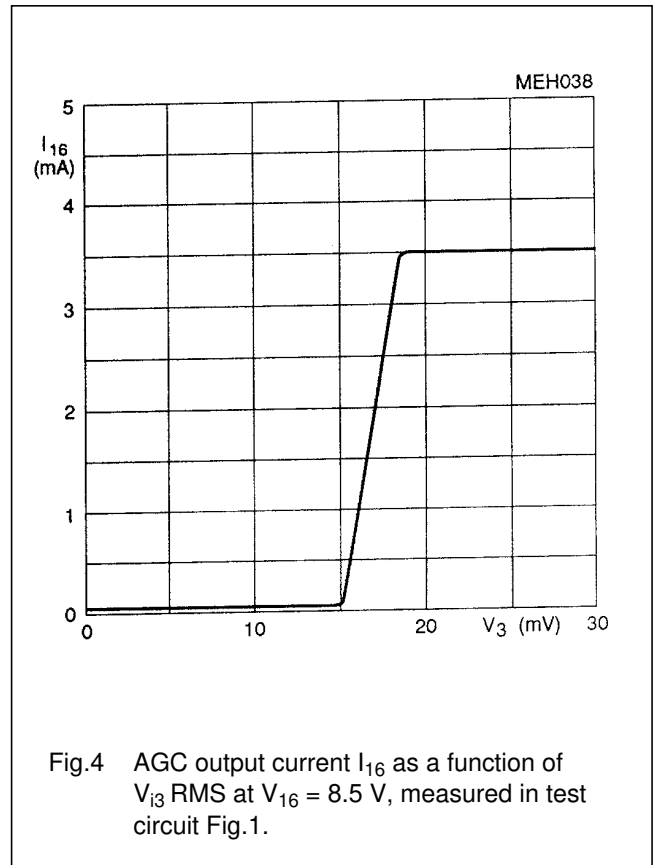
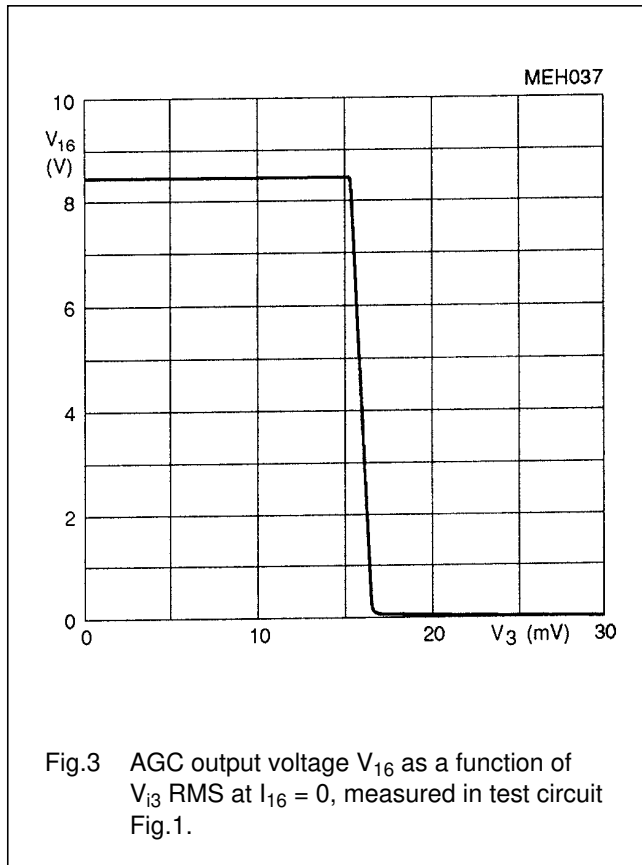

FM front end circuit for CENELEC EN 55020 applications

TDA1575T

APPLICATION INFORMATION

Operating characteristics

Measured in application circuit Fig.7, according to "CENELEC EN 55020, Chapter 4.1 (passive interference suppression)". Measurements are shown in Figs. 8 and 9.

SYMBOL	PARAMETER	CONDITIONS	MIN.	TYP.	MAX.	UNIT
V _S	supply voltage		7	8.5	10	V
I _S	total supply current		–	37	–	mA
f _{RF}	tuning range of RF input		87.5	–	108	MHz
V _{tune}	tuning voltage of RF input		1	–	7	V
G	gain (20 log V _{O IF} / V _{ant})		–	43	–	dB
V _{i ant}	input sensitivity	S/N = 26 dB; R _{ant} = 150 Ω	–	2	–	μV
IR	image rejection	f = 98 MHz	–	64	–	dB
RSS	repeat spot suppression	f = 98 MHz; V _{i ant} = 10 μV	–	89	–	dB
DBS	double beat suppression	f1 = 93 MHz; f2 = 98 MHz				
	DBS1	f _{tune} = 88 MHz	–	81	–	dB
	DBS2	f _{tune} = 103 MHz	–	80	–	dB
	DBS3	f _{tune} = 90.15 MHz	–	85	–	dB
CBS	continuous beat suppression	f1 = 90 MHz; f2 = 100.7 MHz f _{tune} = 95 MHz	–	90	–	dB

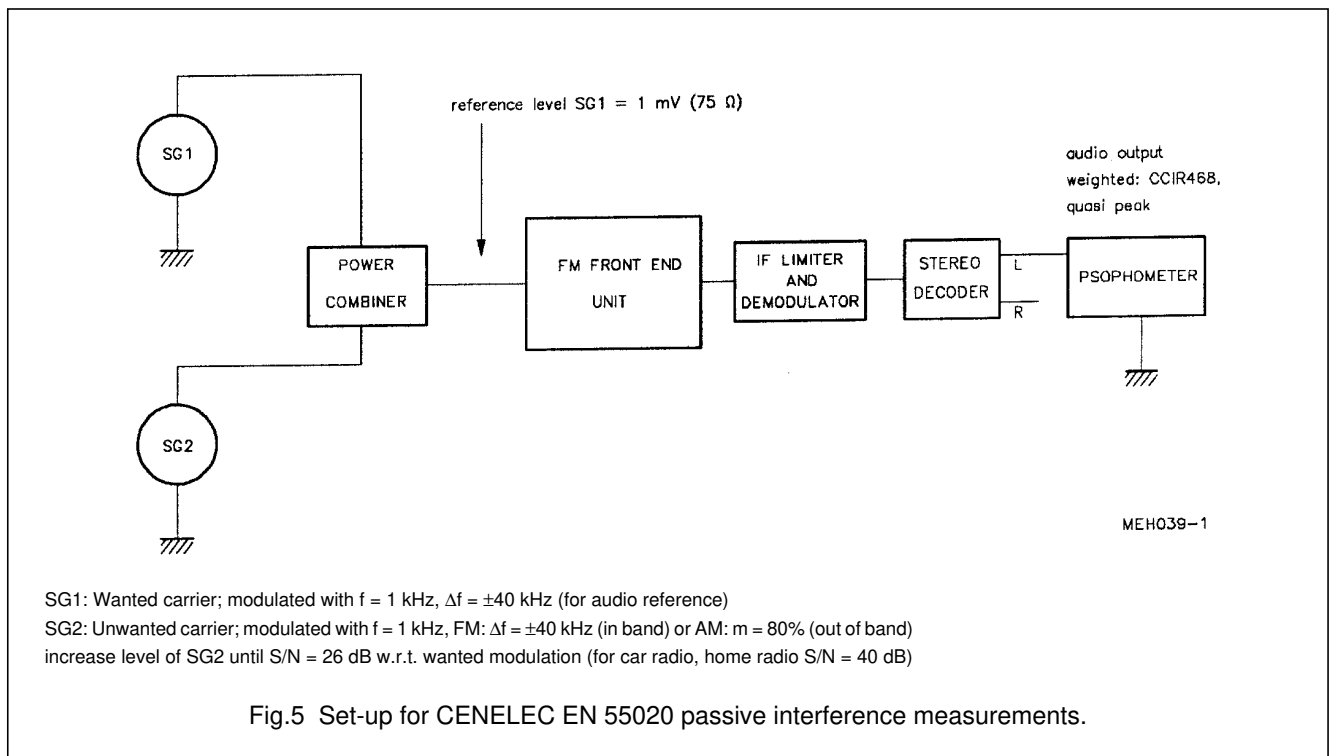
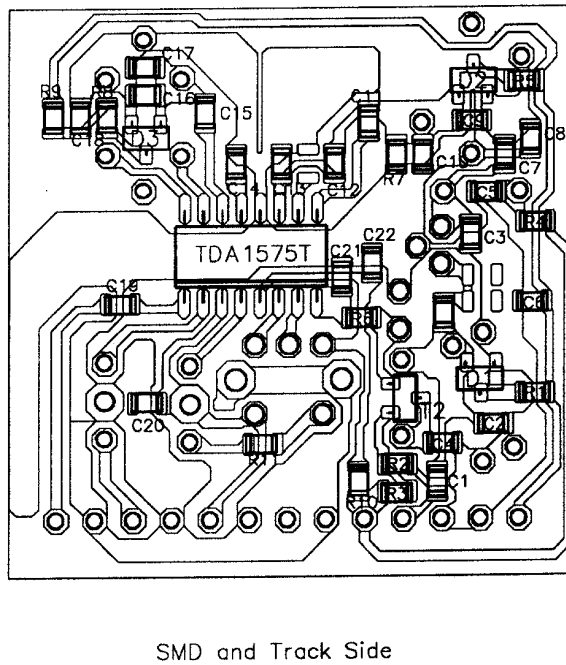
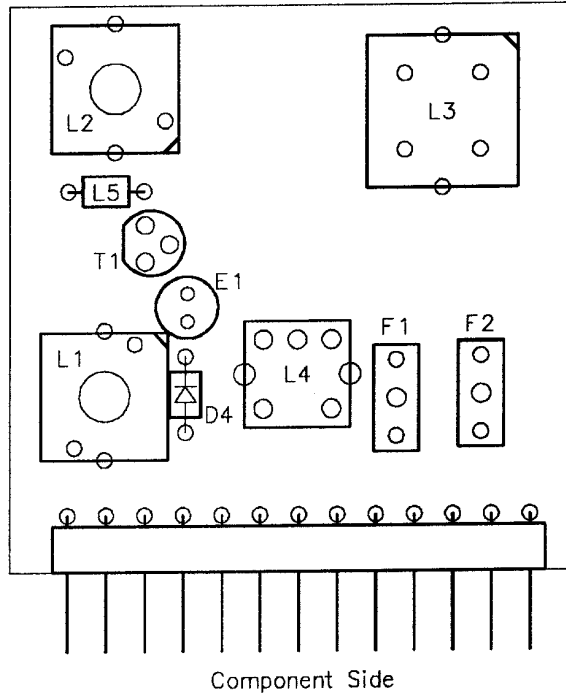

Fig.5 Set-up for CENELEC EN 55020 passive interference measurements.

FM front end circuit for
CENELEC EN 55020 applications

TDA1575T



MEH040

Fig.6 PCB layout of FM front end unit.

FM front end circuit for
CENELEC EN 55020 applications

TDA1575T

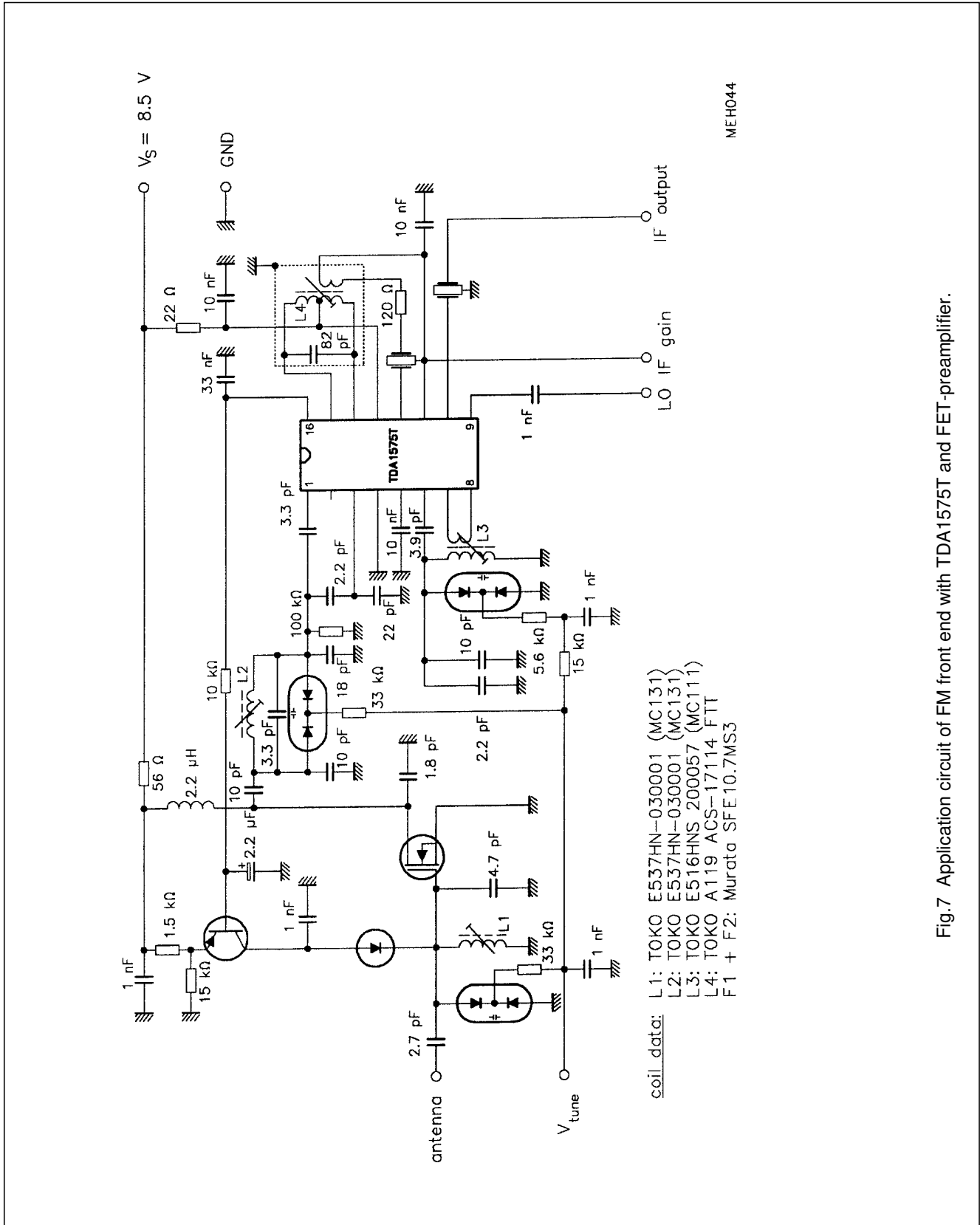

Fig.7 Application circuit of FM front end with TDA1575T and FET-preamplifier.

FM front end circuit for
CENELEC EN 55020 applications

TDA1575T

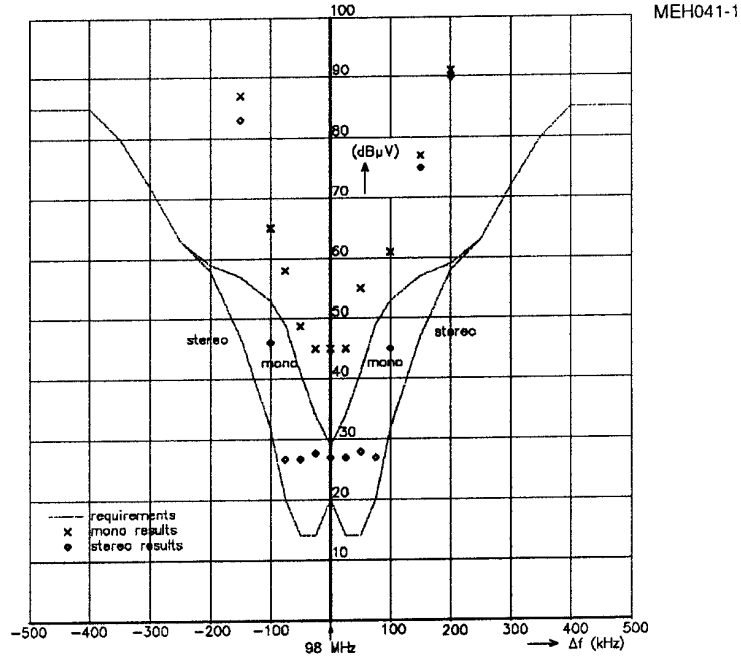

Fig.8 Interference level as a function of detuning for S/N = 26 dB;
IN-BAND passive interference (CENELEC EN 55020).

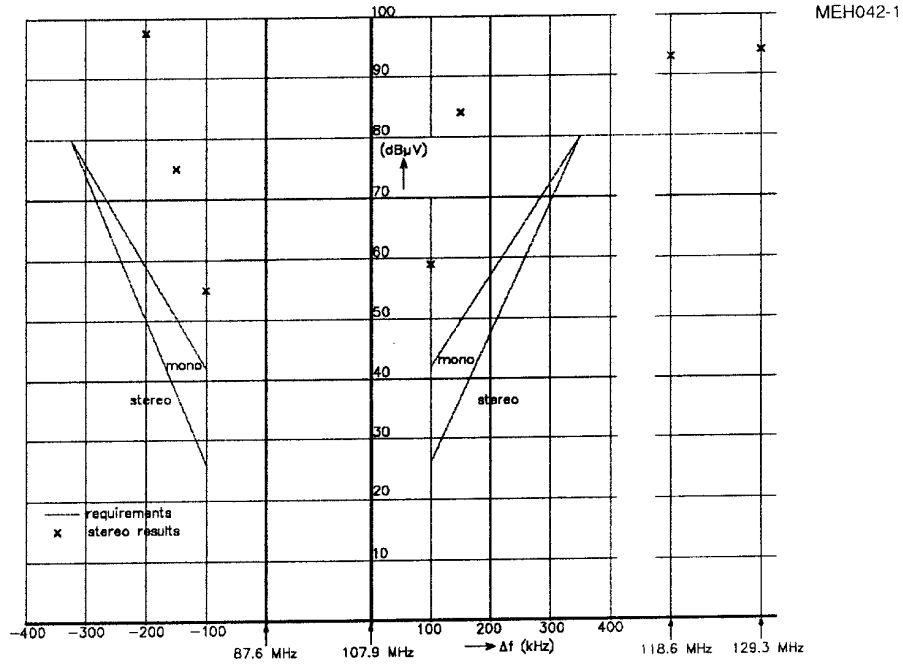
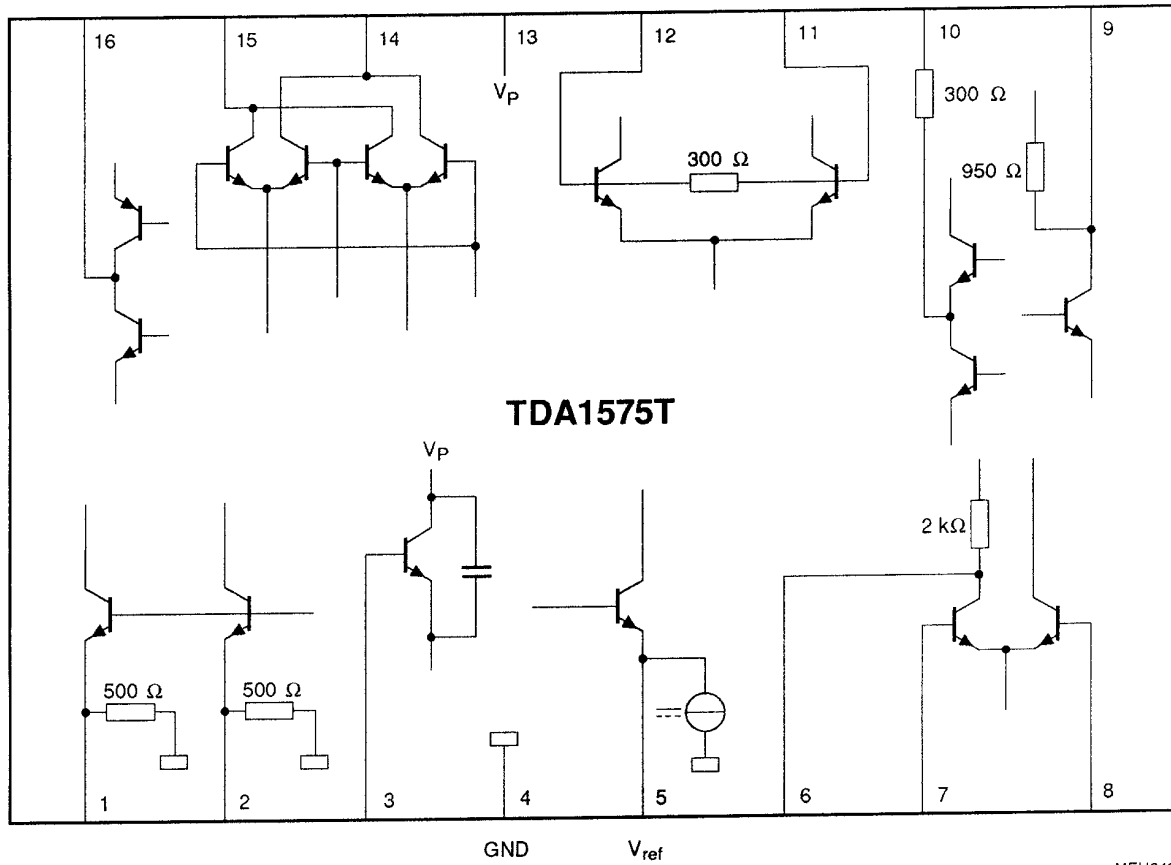

Fig.9 Interference level as a function of detuning for S/N = 26 dB;
OUT-OF-BAND passive interference (CENELEC EN 55020).

FM front end circuit for
CENELEC EN 55020 applications

TDA1575T



MEH043

Fig.10 Internal circuits.

FM front end circuit for
CENELEC EN 55020 applications

TDA1575T

PACKAGE OUTLINE

SO16: plastic small outline package; 16 leads; body width 3.9 mm

SOT109-1

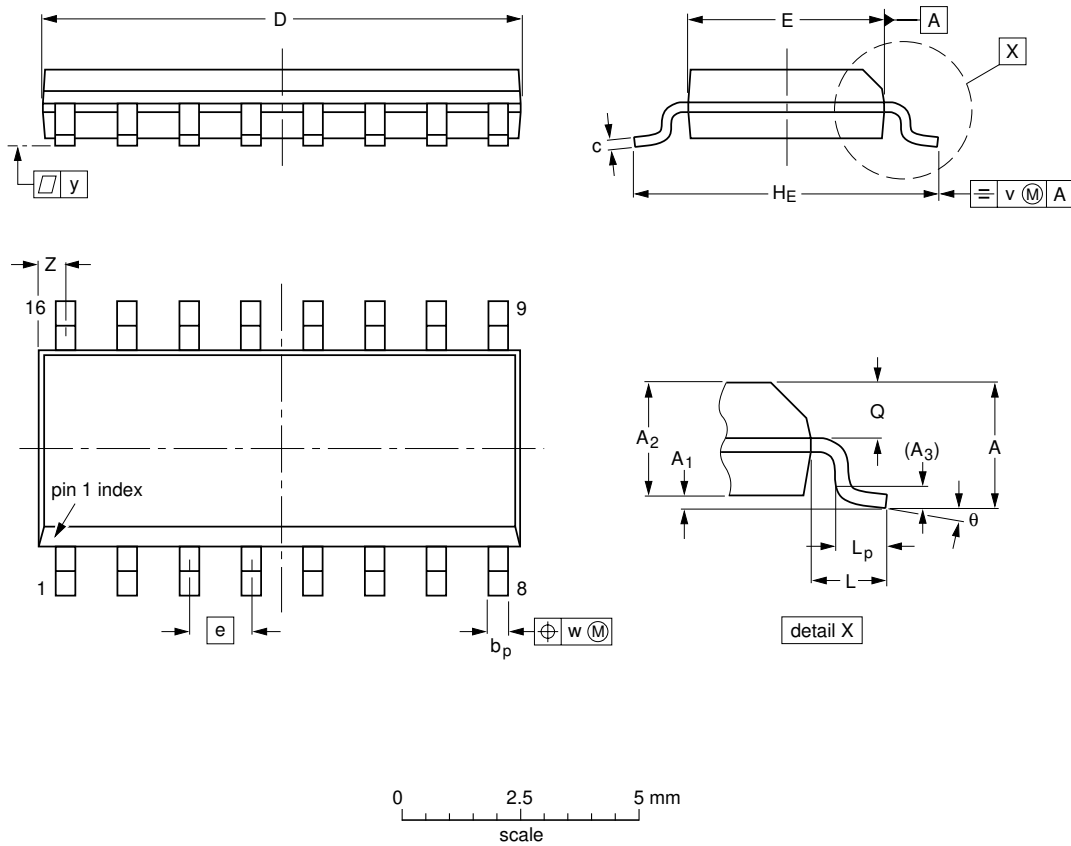

DIMENSIONS (inch dimensions are derived from the original mm dimensions)

UNIT	A max.	A ₁	A ₂	A ₃	b _p	c	D ⁽¹⁾	E ⁽¹⁾	e	H _E	L	L _p	Q	v	w	y	Z ⁽¹⁾	θ
mm	1.75	0.25 0.10	1.45 1.25	0.25	0.49 0.36	0.25 0.19	10.0 9.8	4.0 3.8	1.27	6.2 5.8	1.05	1.0 0.4	0.7 0.6	0.25	0.25	0.1	0.7 0.3	8° 0°
inches	0.069	0.010 0.004	0.057 0.049	0.01	0.019 0.014	0.0100 0.0075	0.39 0.38	0.16 0.15	0.050	0.244 0.228	0.041	0.039 0.016	0.028 0.020	0.01	0.01	0.004	0.028 0.012	

Note

1. Plastic or metal protrusions of 0.15 mm maximum per side are not included.

OUTLINE VERSION	REFERENCES				EUROPEAN PROJECTION	ISSUE DATE
	IEC	JEDEC	EIAJ			
SOT109-1	076E07S	MS-012AC				95-01-23 97-05-22

FM front end circuit for CENELEC EN 55020 applications

TDA1575T

SOLDERING

Introduction

There is no soldering method that is ideal for all IC packages. Wave soldering is often preferred when through-hole and surface mounted components are mixed on one printed-circuit board. However, wave soldering is not always suitable for surface mounted ICs, or for printed-circuits with high population densities. In these situations reflow soldering is often used.

This text gives a very brief insight to a complex technology. A more in-depth account of soldering ICs can be found in our "*IC Package Databook*" (order code 9398 652 90011).

Reflow soldering

Reflow soldering techniques are suitable for all SO packages.

Reflow soldering requires solder paste (a suspension of fine solder particles, flux and binding agent) to be applied to the printed-circuit board by screen printing, stencilling or pressure-syringe dispensing before package placement.

Several techniques exist for reflowing; for example, thermal conduction by heated belt. Dwell times vary between 50 and 300 seconds depending on heating method. Typical reflow temperatures range from 215 to 250 °C.

Preheating is necessary to dry the paste and evaporate the binding agent. Preheating duration: 45 minutes at 45 °C.

Wave soldering

Wave soldering techniques can be used for all SO packages if the following conditions are observed:

- A double-wave (a turbulent wave with high upward pressure followed by a smooth laminar wave) soldering technique should be used.
- The longitudinal axis of the package footprint must be parallel to the solder flow.
- The package footprint must incorporate solder thieves at the downstream end.

During placement and before soldering, the package must be fixed with a droplet of adhesive. The adhesive can be applied by screen printing, pin transfer or syringe dispensing. The package can be soldered after the adhesive is cured.

Maximum permissible solder temperature is 260 °C, and maximum duration of package immersion in solder is 10 seconds, if cooled to less than 150 °C within 6 seconds. Typical dwell time is 4 seconds at 250 °C.

A mildly-activated flux will eliminate the need for removal of corrosive residues in most applications.

Repairing soldered joints

Fix the component by first soldering two diagonally-opposite end leads. Use only a low voltage soldering iron (less than 24 V) applied to the flat part of the lead. Contact time must be limited to 10 seconds at up to 300 °C. When using a dedicated tool, all other leads can be soldered in one operation within 2 to 5 seconds between 270 and 320 °C.

**FM front end circuit for
CENELEC EN 55020 applications**

TDA1575T**DEFINITIONS**

Data sheet status	
Objective specification	This data sheet contains target or goal specifications for product development.
Preliminary specification	This data sheet contains preliminary data; supplementary data may be published later.
Product specification	This data sheet contains final product specifications.
Limiting values	
Limiting values given are in accordance with the Absolute Maximum Rating System (IEC 134). Stress above one or more of the limiting values may cause permanent damage to the device. These are stress ratings only and operation of the device at these or at any other conditions above those given in the Characteristics sections of the specification is not implied. Exposure to limiting values for extended periods may affect device reliability.	
Application information	
Where application information is given, it is advisory and does not form part of the specification.	

LIFE SUPPORT APPLICATIONS

These products are not designed for use in life support appliances, devices, or systems where malfunction of these products can reasonably be expected to result in personal injury. Philips customers using or selling these products for use in such applications do so at their own risk and agree to fully indemnify Philips for any damages resulting from such improper use or sale.

FM front end circuit for
CENELEC EN 55020 applications

TDA1575T

NOTES

Philips Semiconductors – a worldwide company

Argentina: see South America

Australia: 34 Waterloo Road, NORTH RYDE, NSW 2113,
Tel. +61 2 9805 4455, Fax. +61 2 9805 4466

Austria: Computerstr. 6, A-1101 WIEN, P.O. Box 213,
Tel. +43 1 60 101, Fax. +43 1 60 101 1210

Belarus: Hotel Minsk Business Center, Bld. 3, r. 1211, Volodarski Str. 6,
220050 MINSK, Tel. +375 172 200 733, Fax. +375 172 200 773

Belgium: see The Netherlands

Brazil: see South America

Bulgaria: Philips Bulgaria Ltd., Energoproject, 15th floor,
51 James Bourchier Blvd., 1407 SOFIA,
Tel. +359 2 689 211, Fax. +359 2 689 102

Canada: PHILIPS SEMICONDUCTORS/COMPONENTS,
Tel. +1 800 234 7381

China/Hong Kong: 501 Hong Kong Industrial Technology Centre,
72 Tat Chee Avenue, Kowloon Tong, HONG KONG,
Tel. +852 2319 7888, Fax. +852 2319 7700

Colombia: see South America

Czech Republic: see Austria

Denmark: Prags Boulevard 80, PB 1919, DK-2300 COPENHAGEN S,
Tel. +45 32 88 2636, Fax. +45 31 57 0044

Finland: Sinikalliontie 3, FIN-02630 ESPOO,
Tel. +358 9 615800, Fax. +358 9 61580920

France: 4 Rue du Port-aux-Vins, BP317, 92156 SURESNES Cedex,
Tel. +33 1 40 99 6161, Fax. +33 1 40 99 6427

Germany: Hammerbrookstraße 69, D-20097 HAMBURG,
Tel. +49 40 23 53 60, Fax. +49 40 23 536 300

Greece: No. 15, 25th March Street, GR 17778 TAVROS/ATHENS,
Tel. +30 1 4894 339/239, Fax. +30 1 4814 240

Hungary: see Austria

India: Philips INDIA Ltd, Shivsagar Estate, A Block, Dr. Annie Besant Rd.
Worli, MUMBAI 400 018, Tel. +91 22 4938 541, Fax. +91 22 4938 722

Indonesia: see Singapore

Ireland: Newstead, Clonskeagh, DUBLIN 14,
Tel. +353 1 7640 000, Fax. +353 1 7640 200

Israel: RAPAC Electronics, 7 Kehilat Saloniki St, PO Box 18053,
TEL AVIV 61180, Tel. +972 3 645 0444, Fax. +972 3 649 1007

Italy: PHILIPS SEMICONDUCTORS, Piazza IV Novembre 3,
20124 MILANO, Tel. +39 2 6752 2531, Fax. +39 2 6752 2557

Japan: Philips Bldg 13-37, Kohnan 2-chome, Minato-ku, TOKYO 108,
Tel. +81 3 3740 5130, Fax. +81 3 3740 5077

Korea: Philips House, 260-199 Itaewon-dong, Yongsan-ku, SEOUL,
Tel. +82 2 709 1412, Fax. +82 2 709 1415

Malaysia: No. 76 Jalan Universiti, 46200 PETALING JAYA, SELANGOR,
Tel. +60 3 750 5214, Fax. +60 3 757 4880

Mexico: 5900 Gateway East, Suite 200, EL PASO, TEXAS 79905,
Tel. +9-5 800 234 7381

Middle East: see Italy

Netherlands: Postbus 90050, 5600 PB EINDHOVEN, Bldg. VB,
Tel. +31 40 27 82785, Fax. +31 40 27 88399

New Zealand: 2 Wagener Place, C.P.O. Box 1041, AUCKLAND,
Tel. +64 9 849 4160, Fax. +64 9 849 7811

Norway: Box 1, Manglerud 0612, OSLO,
Tel. +47 22 74 8000, Fax. +47 22 74 8341

Philippines: Philips Semiconductors Philippines Inc.,
106 Valero St. Salcedo Village, P.O. Box 2108 MCC, MAKATI,
Metro MANILA, Tel. +63 2 816 6380, Fax. +63 2 817 3474

Poland: Ul. Lukiska 10, PL 04-123 WARSZAWA,
Tel. +48 22 612 2831, Fax. +48 22 612 2327

Portugal: see Spain

Romania: see Italy

Russia: Philips Russia, Ul. Usatcheva 35A, 119048 MOSCOW,
Tel. +7 095 755 6918, Fax. +7 095 755 6919

Singapore: Lorong 1, Toa Payoh, SINGAPORE 1231,
Tel. +65 350 2538, Fax. +65 251 6500

Slovakia: see Austria

Slovenia: see Italy

South Africa: S.A. PHILIPS Pty Ltd., 195-215 Main Road Martindale,
2092 JOHANNESBURG, P.O. Box 7430 Johannesburg 2000,
Tel. +27 11 470 5911, Fax. +27 11 470 5494

South America: Rua do Rocio 220, 5th floor, Suite 51,
04552-903 São Paulo, SÃO PAULO - SP, Brazil,
Tel. +55 11 821 2333, Fax. +55 11 829 1849

Spain: Balmes 22, 08007 BARCELONA,
Tel. +34 3 301 6312, Fax. +34 3 301 4107

Sweden: Kottbygatan 7, Akalla, S-16485 STOCKHOLM,
Tel. +46 8 632 2000, Fax. +46 8 632 2745

Switzerland: Allmendstrasse 140, CH-8027 ZÜRICH,
Tel. +41 1 488 2686, Fax. +41 1 481 7730

Taiwan: Philips Semiconductors, 6F, No. 96, Chien Kuo N. Rd., Sec. 1,
TAIPEI, Taiwan Tel. +886 2 2134 2865, Fax. +886 2 2134 2874

Thailand: PHILIPS ELECTRONICS (THAILAND) Ltd.,
209/2 Sanpavuth-Bangna Road Prakanong, BANGKOK 10260,
Tel. +66 2 745 4090, Fax. +66 2 398 0793

Turkey: Talatpasa Cad. No. 5, 80640 GÜLTEPE/ISTANBUL,
Tel. +90 212 279 2770, Fax. +90 212 282 6707

Ukraine: PHILIPS UKRAINE, 4 Patrice Lumumba str., Building B, Floor 7,
252042 KIEV, Tel. +380 44 264 2776, Fax. +380 44 268 0461

United Kingdom: Philips Semiconductors Ltd., 276 Bath Road, Hayes,
MIDDLESEX UB3 5BX, Tel. +44 181 730 5000, Fax. +44 181 754 8421

United States: 811 East Arques Avenue, SUNNYVALE, CA 94088-3409,
Tel. +1 800 234 7381

Uruguay: see South America

Vietnam: see Singapore

Yugoslavia: PHILIPS, Trg N. Pasica 5/v, 11000 BEOGRAD,
Tel. +381 11 625 344, Fax. +381 11 635 777

For all other countries apply to: Philips Semiconductors, Marketing & Sales Communications,
Building BE-p, P.O. Box 218, 5600 MD EINDHOVEN, The Netherlands, Fax. +31 40 27 24825

Internet: <http://www.semiconductors.philips.com>

© Philips Electronics N.V. 1997

SCA54

All rights are reserved. Reproduction in whole or in part is prohibited without the prior written consent of the copyright owner.

The information presented in this document does not form part of any quotation or contract, is believed to be accurate and reliable and may be changed without notice. No liability will be accepted by the publisher for any consequence of its use. Publication thereof does not convey nor imply any license under patent- or other industrial or intellectual property rights.

Printed in The Netherlands

547027/00/03/pp16

Date of release: April 1993

Document order number: 9397 750 02439

Let's make things better.

Philips
Semiconductors



PHILIPS