



Chipsmall Limited consists of a professional team with an average of over 10 year of expertise in the distribution of electronic components. Based in Hongkong, we have already established firm and mutual-benefit business relationships with customers from,Europe,America and south Asia,supplying obsolete and hard-to-find components to meet their specific needs.

With the principle of “Quality Parts,Customers Priority,Honest Operation,and Considerate Service”,our business mainly focus on the distribution of electronic components. Line cards we deal with include Microchip,ALPS,ROHM,Xilinx,Pulse,ON,Everlight and Freescale. Main products comprise IC,Modules,Potentiometer,IC Socket,Relay,Connector.Our parts cover such applications as commercial,industrial, and automotives areas.

We are looking forward to setting up business relationship with you and hope to provide you with the best service and solution. Let us make a better world for our industry!



Contact us

Tel: +86-755-8981 8866 Fax: +86-755-8427 6832

Email & Skype: info@chipsmall.com Web: www.chipsmall.com

Address: A1208, Overseas Decoration Building, #122 Zhenhua RD., Futian, Shenzhen, China





TDA18211HD

DVB-T Silicon Tuner IC

Rev. 05 — 2 June 2009

Product data sheet

1. General description

The TDA18211HD is a Silicon Tuner IC designed for digital terrestrial (DVB-T) TV reception. The TDA18211HD integrates the overall tuning function, including selectivity, and provides a low-IF output signal.

The TDA18211HD uses integrated IF filters to support 6/7/8 MHz channel bandwidths. The TDA18211HD requires only one single 16 MHz crystal for clock generation. A clock signal is available on crystal oscillator output pins (XTOUTP/XTOUTN) to synchronize the channel decoder and slave front end in case of DVR configuration.

This specification is based on software version 3.4

2. Features

- Fully integrated RF tracking filters for unwanted signal suppression
- Fully integrated IF selectivity (no need for external SAW filters)
- Fully integrated oscillators with no external components
- Integrated wideband gain control
- Alignment free
- RF loop-through for easy implementation in the STB
- Input power level indicator
- Integrated die thermal sensor
- Single 3.3 V power supply
- Low power consumption (780 mW)
- Crystal oscillator output buffer (16 MHz) to allow single crystal applications
- I²C-bus interface compatible with 3.3 V and 5 V microcontrollers
- Three Standby modes
- RoHS packaging

3. Applications

3.1 Target applications

- DVB-T Set-Top-Box (STB) and TV receiver
- Application optimization is described in the application notes

3.2 Key benefits

- The TDA18211HD is a low cost Silicon Tuner targeting digital terrestrial applications. The TDA18211HD matches the performance of the conventional can tuners while reducing the size of the tuner function drastically. Additionally, the following benefits can be stated:
 - ◆ Allows easy on-board integration
 - ◆ Allows easy dual-tuner configuration
 - ◆ Drastically reducing the size of the tuner function and power consumption

4. Quick reference data

Table 1. Quick reference data

$T_{amb} = 25\text{ }^{\circ}\text{C}$; $V_{CC} = 3.3\text{ V}$; IF output level option = 2 V (p-p); IF output load = 1 k Ω on each terminal.

Symbol	Parameter	Conditions	Min	Typ	Max	Unit
f_{RF}	RF frequency	center of channel	174	-	864	MHz
NF_{tun}	tuner noise figure	maximum gain	-	5.5	6	dB
ϕ_n	phase noise		-	-89	-	dBc/Hz
P	power dissipation		-	780	-	mW
$V_{i(max)}$	maximum input voltage	1 dB gain compression, one analog TV signal at RF input (-5 dBm)	-	103	-	dB μ V
α_{image}	image rejection		53	65	-	dB
S_{dig}	digital sensitivity	DVB-T (64 QAM $\frac{2}{3}$); BER = $2 \cdot 10^{-4}$	[1]	-82	-	dBm

[1] Measured with TDA10048HN channel decoder.

5. Ordering information

Table 2. Ordering information

Type number	Package		Version
	Name	Description	
TDA18211HD/G2	HLQFN64R	plastic thermal enhanced low profile quad flat package; no leads; 64 terminals; resin based; body 9 × 9 × 1.6 mm	SOT903-1

6. Block diagram

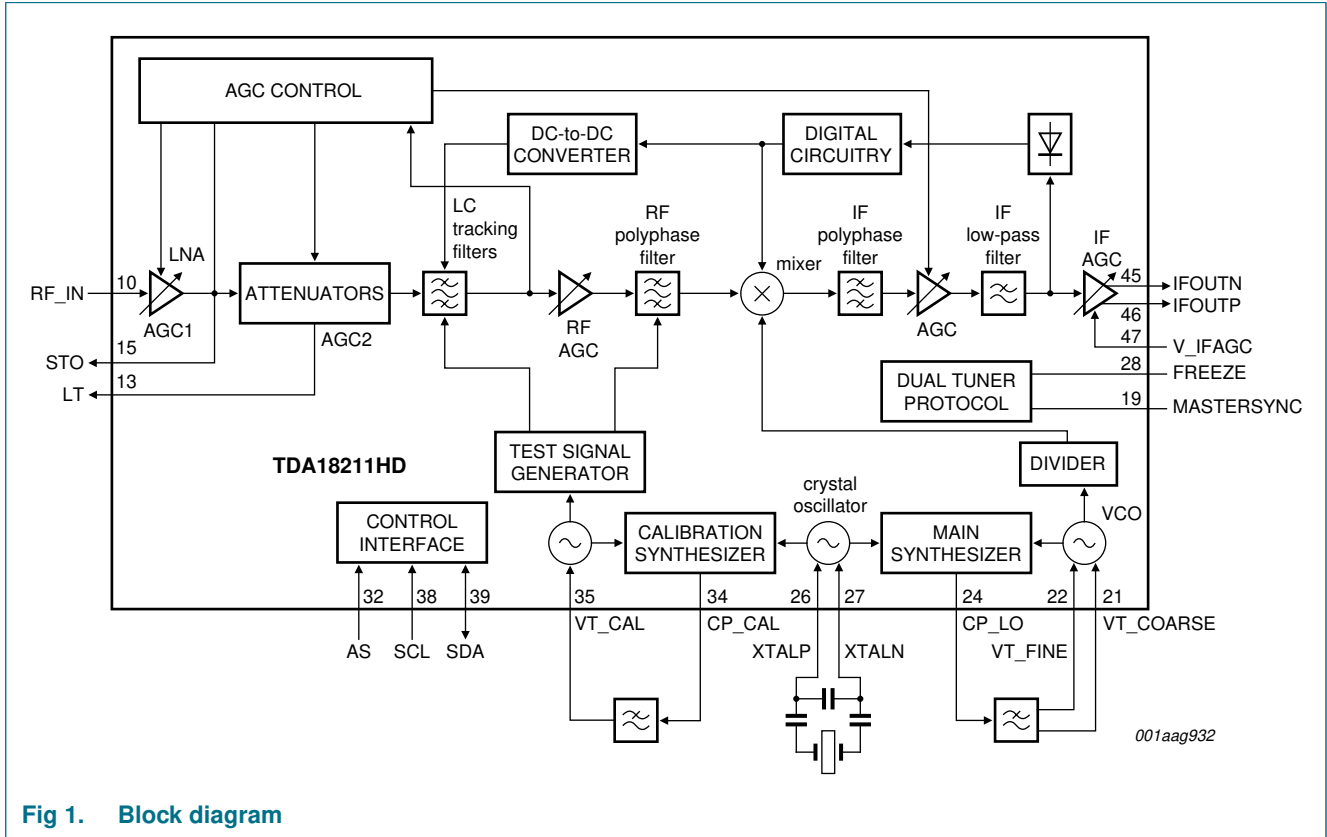

Fig 1. Block diagram

7. Pinning information

7.1 Pinning

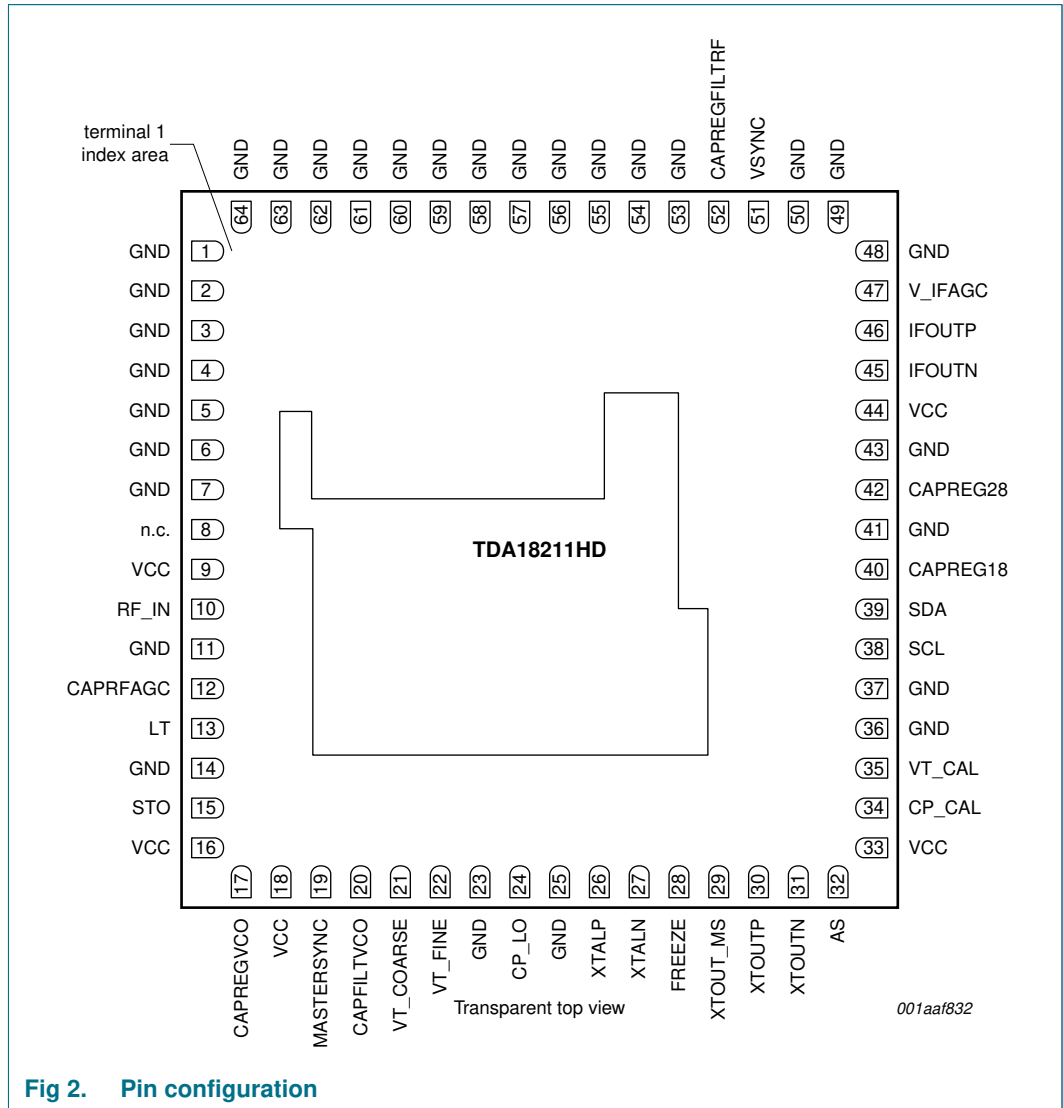

Fig 2. Pin configuration

7.2 Pin description

Table 3. Pin description

Symbol	Pin	Description
GND	1 to 7	ground
n.c.	8	not connected
VCC	9	3.3 V supply voltage
RF_IN	10	unbalanced RF (TV) input
GND	11	ground
CAPRFAGC	12	RF AGC filtering
LT	13	loop-through output

Table 3. Pin description ...continued

Symbol	Pin	Description
GND	14	ground
STO	15	slave tuner output
VCC	16	3.3 V supply voltage
CAPREGVCO	17	VCO supply decoupling
VCC	18	3.3 V supply voltage
MASTERSYNC	19	synchronization signal for dual-tuner applications; leave open for single-tuner applications
CAPFILTVCO	20	VCO reference decoupling
VT_COARSE	21	LO oscillator tuning voltage input
VT_FINE	22	LO oscillator tuning voltage input
GND	23	ground
CP_LO	24	charge pump of the local synthesizer
GND	25	ground
XTALP	26	crystal oscillator input
XTALN	27	crystal oscillator input
FREEZE	28	synchronization signal for multi-tuner applications; leave open for single-tuner applications
XTOUT_MS	29	XTOUT mode and master/slave selection input
XTOUTP	30	crystal oscillator output buffer
XTOUTN	31	crystal oscillator output buffer
AS	32	I ² C-bus address selection input
VCC	33	3.3 V supply voltage
CP_CAL	34	charge pump of the calibration synthesizer
VT_CAL	35	tuning voltage of the calibration synthesizer
GND	36, 37	ground
SCL	38	I ² C-bus clock input
SDA	39	I ² C-bus data input/output
CAPREG18	40	internal regulator decoupling
GND	41	ground
CAPREG28	42	internal regulator decoupling
GND	43	ground
VCC	44	3.3 V supply voltage
IFOUTN	45	IF output
IFOUTP	46	IF output
V_IFAGC	47	IF gain control input
GND	48 to 50	ground
VSYNC	51	vertical synchronization input for analog applications; connect to ground for digital applications
CAPREGFILTRF	52	internal regulator decoupling
GND	53 to 64	ground
-	exposed die	ground

8. Functional description

The RF input signal is driven to a low-noise amplifier. It is then band-pass filtered, amplified and fed to the image rejection mixer. The mixer downconverts the RF signal to a low IF, which depends on channel bandwidth (standard IF filters are implemented for 6/7/8 MHz channel bandwidths; see [Table 41](#)).

The gain between the antenna pin (pin RF_IN) and the loop-through pin (pin LT) is 0 dB.

The TDA18211HD requires a single 16 MHz crystal for clock generation.

When bit XTOUT_ON = 1, a differential sine wave clock reference is available on pins XTOUTP and XTOUTN to drive a channel decoder.

8.1 Master and slave operation

The TDA18211HD allows easy dual-tuner configuration.

Each individual tuner has to be set either in Master mode or Slave mode by applying a DC voltage on the XTOUT_MS pin; see [Table 4](#). This will decide whether the crystal oscillator part is used as negative impedance connected to the crystal part or as a current buffer.

Table 4. Master and slave selection

Voltage on pin XTOUT_MS	Tuner type	Crystal oscillator
0 V to 0.1V _{CC}	master	negative impedance presented to the crystal
0.4V _{CC} to 0.6V _{CC}	slave	current input buffer

In dual-tuner application:

- The first tuner is set in Master mode
- The second tuner has to be set in Slave mode

In single-tuner application:

- The tuner must be set in Master mode.

8.2 Tuner outputs

The tuner provides a slave tuner output (pin STO) and a loop-through output (pin LT). Those outputs are used to transmit the antenna signal to other tuners. Each output has its own characteristics (see [Table 56](#) and [Table 57](#))

8.2.1 Loop-through output

The gain between the antenna connector and the loop-through pin (pin LT) equals 0 dB. This pin can be connected to any consumer electronic equipment.

8.2.2 Slave tuner output

The slave tuner output (pin STO) must be connected to the RF input of the slave tuner TDA18211HD in case of dual-tuner applications.

The gain between the antenna connector and the slave tuner output can change according to the input level. The slave tuner will automatically compensate the gain change, using the MASTERSYNC and FREEZE signals.

8.3 Crystal input mode

The TDA18211HD requires a 16 MHz crystal reference. The chosen crystal must withstand at least 100 μ W drive level. An additional shunt capacitor as shown in [Figure 1](#) is also needed. Its typical value is 5.6 pF. The quartz references for which performance is guaranteed are:

- NDK NX5032
- Siward SX-5032
- TXC 9C series
- Chungo Elcom HC49/S profile

Clock reference:

- In Master mode, the clock reference must be provided by a 16 MHz crystal connected between pins XTALP and XTALN of the master tuner
- In Slave mode, the clock reference must be provided by pins XTOUTP and XTOUTN of the tuner in Master mode to pins XTALP and XTALN of the tuner in Slave mode

8.4 Crystal output mode

Pins XTOUTP and XTOUTN deliver a symmetrical sine waveform to drive the channel decoder and/or IF demodulator. The load on both outputs should be made similar to ensure optimum performances. Hence, if only one crystal output is used, the unused output should be loaded by an equivalent capacitance.

9. Control interface

9.1 I²C-bus format, write/read mode

Remark: In I²C-bus read mode, the TDA18211HD must read the entire I²C map with the required subaddress 00h. The number of bytes to be read is 16, or 39 in extended register mode; see [Table 7](#). Reading write-only bits can return values that are different from the programmed values.

Table 5. I²C-bus format

Name	Byte name	Sub address	Bit								
			7	6	5	4	3	2	1	0	
Address byte 1	-	-	1	1	0	0	0	MA[1]	MA[0]	R/W	
Address byte 2	-	-	0	0	AD[5:0]						
ID byte	ID	00h	1	ID[6:0]							
Thermo byte	TM	01h	POR	LOCK	TM_RANGE	TM_ON	TM_D[3:0]				
Power level byte	PL	02h	POWER_LEVEL[7:0]								
Easy Prog byte 1	EP1	03h	POWER_LEVEL[8]	DIS_POWER_LEVEL	0	RF_CAL_OK	IR_CAL_OK	BP_FILTER[2:0]			
Easy Prog byte 2	EP2	04h	RF_BAND[2:0]			GAIN_TAPER[4:0]					
Easy Prog byte 3	EP3	05h	SM	SM_LT	SM_XT	STD[4:0]					
Easy Prog byte 4	EP4	06h	FM_RFN	XTOUT_ON	1	IF_LEVEL[2:0]			CAL_MODE[1:0]		
Easy Prog byte 5	EP5	07h	EXTENDED_REG	IR_GSTEP[2:0]			0	IR_MEAS[2:0]			
Cal Post-Divider byte	CPD	08h	CAL_POST_DIV[7:0]								
Cal Divider byte 1	CD1	09h	0	CAL_DIV[22:16]							
Cal Divider byte 2	CD2	0Ah	CAL_DIV[15:8]								
Cal Divider byte 3	CD3	0Bh	CAL_DIV[7:0]								
Main Post-Divider byte	MPD	0Ch	IF_NOTCH	MAIN_POST_DIV[6:0]							
Main Divider byte 1	MD1	0Dh	0	MAIN_DIV[22:16]							
Main Divider byte 2	MD2	0Eh	MAIN_DIV[15:8]								
Main Divider byte 3	MD3	0Fh	MAIN_DIV[7:0]								
Extended byte 1	EB1	10h	EB1[7:3]					CALVCO_FORLON	AGC1_ALWAYS_MASTERN	AGC1_FIRSTN	
Extended byte 2	EB2	11h	EB2[7:0]								
Extended byte 3	EB3	12h	EB3[7:0]								
Extended byte 4	EB4	13h	EB4[7:6]		LO_FORCE_SRCE	EB4[4:0]					
Extended byte 5	EB5	14h	EB5[7:0]								
Extended byte 6	EB6	15h	EB6[7:0]								

Table 5. I²C-bus format ...continued

Name	Byte name	Sub address	Bit							
			7	6	5	4	3	2	1	0
Extended byte 7	EB7	16h	EB7[7:6]		CAL_FORCE_SRCE	EB7[4:0]				
Extended byte 8	EB8	17h	CID_ALARM	EB8[6:4]			EB8[3]	EB8[2:0]		
Extended byte 9	EB9	18h	EB9[7:0]							
Extended byte 10	EB10	19h	EB10[7:6]			CID_GAIN[5:0]				
Extended byte 11	EB11	1Ah	EB11[7:0]							
Extended byte 12	EB12	1Bh	EB12[7:6]		PD_AGC1_DET	PD_AGC2_DET	EB12[3:0]			
Extended byte 13	EB13	1Ch	EB13[7]	RFC_K[2:0]			RFC_M[1:0]		EB13[1:0]	
Extended byte 14	EB14	1Dh	RFC_CPROG[7:0]							
Extended byte 15	EB15	1Eh	EB15[7:4]				EB15[3:0]			
Extended byte 16	EB16	1Fh	EB16[7:0]							
Extended byte 17	EB17	20h	EB17[7:0]							
Extended byte 18	EB18	21h	AGC1_LOOP_OFF	EB18[6:2]				AGC1_GAIN[1:0]		
Extended byte 19	EB19	22h	EB19[7:0]							
Extended byte 20	EB20	23h	EB20[7:6]		FORCE_LOCK	EB20[4:0]				
Extended byte 21	EB21	24h	AGC2_LOOP_OFF	EB21[6:2]				AGC2_GAIN[1:0]		
Extended byte 22	EB22	25h	EB22[7]	RF_TOP[2:0]			IF_TOP[3:0]			
Extended byte 23	EB23	26h	EB23[7:3]				FORCELP_FC2_EN	LP_FC[2]	EB23[0]	

9.2 I²C-bus at power-on reset

Table 6. I²C-bus at power-on reset^[1]

Name	Byte	Subaddress	Bit								
			7	6	5	4	3	2	1	0	
Address byte 1	-	-	1	1	0	0	0	0	MA[1]	MA[0]	X
Address byte 2	-	-	X	X	AD[5]	AD[4]	AD[3]	AD[2]	AD[1]	AD[0]	
ID byte	ID	00h	1	0	0	0	0	0	1	0	0
Thermo byte	TM	01h	1	0	0	0	X	X	X	X	X
Power Level byte	PL	02h	X	X	X	X	X	X	X	X	X
Easy Prog byte 1	EP1	03h	X	1	0	0	0	0	1	1	0
Easy Prog byte 2	EP2	04h	1	1	0	1	1	1	1	1	1
Easy Prog byte 3	EP3	05h	1	0	0	1	0	0	0	1	0
Easy Prog byte 4	EP4	06h	0	1	1	0	0	0	0	0	0
Easy Prog byte 5	EP5	07h	0	0	1	1	0	0	0	0	0
Cal Post-Divider byte	CPD	08h	0	0	0	0	0	0	0	0	0
Cal Divider byte 1	CD1	09h	0	0	0	0	0	0	0	0	0
Cal Divider byte 2	CD2	0Ah	0	0	0	0	0	0	0	0	0
Cal Divider byte 3	CD3	0Bh	0	0	0	0	0	0	0	0	0
Main Post-Divider byte	MPD	0Ch	0	0	0	0	0	0	0	0	0
Main Divider byte 1	MD1	0Dh	0	0	0	0	0	0	0	0	0
Main Divider byte 2	MD2	0Eh	0	0	0	0	0	0	0	0	0
Main Divider byte 3	MD3	0Fh	0	0	0	0	0	0	0	0	0
Extended byte 1	EB1	10h	1	1	1	1	1	1	1	1	1
Extended byte 2	EB2	11h	0	0	0	0	0	0	0	0	1
Extended byte 3	EB3	12h	1	0	0	0	0	0	1	0	0
Extended byte 4	EB4	13h	0	1	0	0	0	0	0	0	1
Extended byte 5	EB5	14h	0	0	0	0	0	0	0	0	1
Extended byte 6	EB6	15h	1	0	0	0	0	0	1	0	0
Extended byte 7	EB7	16h	0	1	0	0	0	1	0	0	0
Extended byte 8	EB8	17h	0	1	1	1	X	1	0	0	1
Extended byte 9	EB9	18h	0	0	0	0	0	0	0	0	0
Extended byte 10	EB10	19h	X	X	X	X	X	X	X	X	X
Extended byte 11	EB11	1Ah	1	0	0	0	0	0	1	1	0
Extended byte 12	EB12	1Bh	0	0	0	0	0	0	1	1	1
Extended byte 13	EB13	1Ch	1	1	0	0	0	0	0	1	0
Extended byte 14	EB14	1Dh	0	0	0	0	0	0	0	0	0
Extended byte 15	EB15	1Eh	1	0	0	0	0	X	X	X	X
Extended byte 16	EB16	1Fh	0	0	0	X	X	X	X	0	0
Extended byte 17	EB17	20h	0	0	0	X	X	X	X	X	X
Extended byte 18	EB18	21h	0	0	0	0	0	0	0	0	0
Extended byte 19	EB19	22h	0	0	0	X	X	X	X	0	0
Extended byte 20	EB20	23h	1	0	0	X	X	X	X	X	X

Table 6. I²C-bus at power-on reset^[1] ...continued

Name	Byte	Subaddress	Bit							
			7	6	5	4	3	2	1	0
Extended byte 21	EB21	24h	0	0	1	1	0	0	1	1
Extended byte 22	EB22	25h	0	1	0	0	1	0	0	0
Extended byte 23	EB23	26h	1	0	1	1	0	0	0	0

[1] X indicates a bit not changed on reset.

9.3 Description of symbols used in I²C-bus format table

Table 7. I²C-bus registers bits explanation

Address	Byte	Symbol	Description	Reference
		MA[1:0]	programmable address bits	Table 8
		AD[5:0]	programmable address bits of the first byte of the programming	Table 9
Data bytes				
00h	ID	ID[6:0]	chip identification number	Table 10
01h	TM	POR	Power-on reset bit	Table 11
		LOCK	indicates that the main synthesizer is locked to the programmed frequency	
		TM_RANGE	range selection bit for the internal die sensor	
		TM_ON	enables die temperature measurement	
		TM_D[3:0]	data from die temperature measurement (read only)	
02h	PL	POWER_LEVEL[7:0]	Power level indicator value (read only)	Table 12
03h	EP1	POWER_LEVEL[8]	Power level indicator value (read only)	Table 12
		DIS_POWER_LEVEL	disables the power-on level function	Table 13
		RF_CAL_OK	indicates that the RF tracking filter calibration procedure has been successful	
		IR_CAL_OK	indicates that the complete image rejection calibration procedure has been successful	
		BP_FILTER[2:0]	RF band-pass filter selection	
04h	EP2	RF_BAND[2:0]	RF tracking filter band selection	Table 14
		GAIN_TAPER[4:0]	gain taper value	
05h	EP3	SM	Sleep mode, Standby modes	Table 15
		SM_LT		
		SM_XT		
		STD[4:0]	define the standard	
06h	EP4	FM_RFN	selection which input is fed to RF filter	Table 17
		XTOUT_ON	provides the 16 MHz on the XTOUTP and XTOUTN pins	
		IF_LEVEL[2:0]	IF output level selection	
		CAL_MODE[1:0]	calibration mode selection	
07h	EP5	EXTENDED_REG	enables the extended register addressing	Table 18
		IR_GSTEP[2:0]	gain step for image rejection calibration	
		IR_MEAS[2:0]	image rejection measurement frequency range	
08h	CPD	CAL_POST_DIV[7:0]	calibration synthesizer post-divider	Table 19

Table 7. I²C-bus registers bits explanation ...continued

Address	Byte	Symbol	Description	Reference
09h	CD1	CAL_DIV[22:16]	calibration synthesizer main divider bits	Table 20
0Ah	CD2	CAL_DIV[15:8]	calibration synthesizer main divider bits	Table 20
0Bh	CD3	CAL_DIV[7:0]	calibration synthesizer main divider bits	Table 20
0Ch	MPD	IF_NOTCH	adds a DC notch in IF for a better adjacent channels rejection; depends on standards	Table 21
		MAIN_POST_DIV[6:0]	LO synthesizer post-divider bits	
0Dh	MD1	MAIN_DIV[22:16]	LO synthesizer main divider bits	Table 22
0Eh	MD2	MAIN_DIV[15:8]	LO synthesizer main divider bits	Table 22
0Fh	MD3	MAIN_DIV[7:0]	LO synthesizer main divider bits	Table 22
Extended bytes				
10h	EB1	CALVCO_FORLON	determines which VCO is used during Normal mode operations	Table 23
		AGC1_ALWAYS_MASTERN	enables AGC1 normal operation whatever the tuner type (master or slave)	
		AGC1_FIRSTN	determines which AGC (1 or 2) will be detected when detectors 1 and 2 are up	
13h	EB4	LO_FORCESRCE	forces the main PLL charge pump to source current to the main PLL loop filter	Table 23
15h	EB6	CAL_FORCESRCE	forces the calibration PLL charge pump to source current to the calibration PLL loop filter	Table 23
17h	EB8	CID_ALARM	indicates that signal sensed by the power detector used during calibrations is out of range	Table 23
19h	EB10	CID_GAIN[5:0]	calibration power detector output	Table 23
1Bh	EB12	PD_AGC1_DET	power-down of AGC1 detector	Table 23
		PD_AGC2_DET	power-down of AGC2 detector	
1Ch	EB13	RFC_K[2:0]	parameter used during the RF tracking filters calibration	Table 23
		RFC_M[1:0]	parameter used during the RF tracking filters calibration	
1Dh	EB14	RFC_CPROG[7:0]	tuning word of the RF tracking filters	Table 23
21h	EB18	AGC1_LOOP_OFF	turns off the AGC1 loop	Table 23
		AGC1_GAIN[1:0]	AGC1 gain	
23h	EB20	FORCE_LOCK	forces the internal lock indicator to logic 1	Table 23
24h	EB21	AGC2_LOOP_OFF	turns off the AGC2 loop	Table 23
		AGC2_GAIN[1:0]	AGC2 gain	
25h	EB22	RF_TOP[2:0]	Take Over Point (TOP) of the RF AGC, detection in RF	Table 23
		IF_TOP[3:0]	TOP of the RF AGC, detection in IF	
26h	EB23	FORCELP_FC2_EN	1.5 MHz bandwidth filter selection	Table 23
		LP_FC[2]		

9.3.1 I²C-bus address selection

The module address contains programmable address bits (MA[1:0]), which offer the possibility to have several synthesizers (up to 4) in one system by applying a specific voltage on the AS input (V_{AS}).

Table 8. Address byte 1 bit description

Legend: * power-on reset value

Bit	Symbol	Access	Value	Description
7 to 3	-	R/W	1 1000*	must be set to 1 1000
2 to 1	MA[1:0]	R/W		programmable address bits
			00	V _{AS} = 0 V to 0.1 × V _{CC}
			01	V _{AS} = 0.2 × V _{CC} to 0.3 × V _{CC}
			10	V _{AS} = 0.4 × V _{CC} to 0.6 × V _{CC}
			11	V _{AS} = 0.9 × V _{CC} to V _{CC}
0	R/W	R/W	0	write mode
			1	read mode

Table 9. Address byte 2 bit description

Legend: * power-on reset value

Bit	Symbol	Access	Value	Description
7 to 6	-	R/W	00	must be set to 00
5 to 0	AD[5:0]	R/W	-	programmable address bits of the first byte of the programming

9.3.2 Description of chip ID byte

Table 10. ID - Identification byte (subaddress 00h) bit description

Legend: * power-on reset value

Bit	Symbol	Access	Value	Description
7	-	R	1*	must be logic 1
6 to 0	ID[6:0]	R	000 0100*	TDA18211HD/C2 identification number

9.3.3 Description of temperature sensor byte

The temperature sensor is not available in Device-off mode as it requires a 16 MHz clock to operate.

Table 11. TM - Thermo byte (subaddress 01h) bit description

Legend: * power-on reset value

Bit	Symbol	Access	Value	Description
7	POR	R	1*	power supply falls below the power-on reset level and is reset after a read operation ending with a stop condition
			0	power supply is above the power-on reset level
6	LOCK	R	1	main synthesizer is locked to the programmed frequency
			0*	main synthesizer is not locked to the programmed frequency

Table 11. TM - Thermo byte (subaddress 01h) bit description ...continued

Legend: * power-on reset value

Bit	Symbol	Access	Value	Description
5	TM_RANGE	R/W		temperature range selection for the internal die sensor (see Table 50)
			1	92 °C to 122 °C
			0*	60 °C to 90 °C
4	TM_ON	R/W	1	enables die temperature measurement (see Table 50)
			0*	disables die temperature measurement (see Table 50)
3 to 0	TM_D[3:0]	R	XXXX	data from die temperature measurement (see Table 50)

9.3.4 Description of power level byte (read mode)

There are 9 power level bits, dispatched in byte 2 and 3. They indicate the composite voltage gain of the LNA, the loaded attenuator voltage gain, and the level at the input of the RF AGC.

Table 12. PL - Power level (address 02h and 03h) bit description

Legend: * power-on reset value

Address	Register	Bit	Symbol	Access	Value	Description	
03h	EP1	7	POWER_LEVEL[8]	R		AGC2 gain, attenuator voltage gain included load, the attenuator load is 50 Ω (explaining the maximum gain of -6 dB)	
02h	PL	7	POWER_LEVEL[7]	R	00		-15 dB
					01		-12 dB
					10		-9 dB
					11		-6 dB
6 to 5	POWER_LEVEL[6:5]	R			AGC1 gain, LNA voltage gain, the LNA voltage gain assumes a 75 Ω source impedance and a low output impedance		
4 to 0	POWER_LEVEL[4:0]	R			00	6 dB	
					01	9 dB	
					10	12 dB	
					11	15 dB	
					0 0000	103 dBμV (RMS value)	
0 0001	102 dBμV (RMS value)						
...	...						
1 1110	73 dBμV (RMS value)						
1 1111	72 dBμV (RMS value)						

9.3.5 Description of Easy Prog byte 1

Table 13. EP1 - Easy Prog byte 1 (subaddress 03h) bit description

Legend: * power-on reset value

Bit	Symbol	Access	Value	Description
7	POWER_LEVEL[8]	R		see Table 12
6	DIS_POWER_LEVEL	R/W	1*	power level disabled
			0	power level enabled
5	-	R/W	0*	must be set to logic 0
4	RF_CAL_OK	R/W		RF tracking filter calibration procedure (see Section 9.4.9); updated each time the procedure is started
			1	successful
			0*	not successful
3	IR_CAL_OK	R/W		complete image rejection calibration procedure (see Section 9.4.4); can only be reset with POR
			1	successful
			0*	not successful
2 to 0	BP_FILTER[2:0]	R/W	110*	RF band-pass filter selection (see Table 42)

9.3.6 Description of Easy Prog byte 2

Table 14. EP2 - Easy Prog byte 2 (subaddress 04h) bit description

Legend: * power-on reset value

Bit	Symbol	Access	Value	Description
7 to 5	RF_BAND[2:0]	R/W	110*	RF tracking filter band selection (see Table 43)
4 to 0	GAIN_TAPER[4:0]	R/W		gain taper value (see Table 47)
			1 1111*	minimum attenuation
			0 0000	maximum attenuation

9.3.7 Description of Easy Prog byte 3

The TDA18211HD has three different Standby modes. Two Standby modes are dedicated to special application demands; the real Standby mode is called 'device-off'. It represents the smallest achievable power consumption.

Table 15. EP3 - Easy Prog byte 3 (subaddress 05h) bit description

Legend: * power-on reset value

Bit	Symbol	Access	Value	Description
7	SM	R/W	1*	Sleep mode (see Table 16)
			0	Normal mode (see Table 16)
6	SM_LT	R/W	0*	see Table 16
5	SM_XT	R/W	0*	see Table 16
4 to 0	STD[4:0]	R/W	1 0010*	description of standards (see Table 41)

Table 16. Standby modes^[1]

Bit			Circuit			Mode
SM	SM_LT	SM_XT	Loop-through	Slave-tuner output	Crystal oscillator	
0	0	0	on	on	on	Normal mode
1	0	0	on	on	on	Standby mode with crystal oscillator, slave-tuner output and loop-through output on
1	1	0	off	off	on	Standby mode with only crystal oscillator and its output buffer on
1	1	1	off	off	off	Device-off mode

[1] In all modes, the I²C-bus interface remains active. All other codes are not valid.

9.3.8 Description of Easy Prog byte 4

Table 17. EP4 - Easy Prog byte 4 (subaddress 06h) bit description

Legend: * power-on reset value

Bit	Symbol	Access	Value	Description
7	FM_RFN	R/W		selection which input is fed to RF filter
			1	FM input (RF LNA on; FM LNA on)
			0*	RF input (RF LNA on; FM LNA off)
6	XTOUT_ON	R/W	1*	16 MHz on pins XTOUTP and XTOUTN
			0	not 16 MHz on pins XTOUTP and XTOUTN
3	-	R/W	1*	must be set to logic 1
4 to 2	IF_LEVEL[2:0]	R/W		IF output level selection and attenuation with regard to 2 V (p-p)
			000*	2 V (p-p); 0 dB
			001	1.25 V (p-p); 4 dB
			010	1 V (p-p); 6 dB
			011	0.8 V (p-p); 8 dB
			100	not used
			101	not used
			110	not used
1 to 0	CAL_MODE[1:0]	R/W		calibration mode selection
			00*	no calibration (Normal mode)
			01	Power detection mode
			10	image rejection calibration (IRCAL) mode
			11	RF tracking filters calibration (RFCAL) mode

It is recommended to follow the flowcharts described in [Section 9.4](#) in order to perform any calibration, as they require a precise set of sequential operations. The further comments can only give an overview of what is typically done during the flowchart.

The TDA18211HD has two calibration modes: one for the image rejection calibration, and one for the RF tracking filters calibration.

The image rejection calibration consists in optimizing some tunable parameters inside the mixer throughout a set of internal measurements, leading to ensure a 65 dB typical value of image rejection. The internal signal used during this phase is generated by the PLL calibration (CAL PLL).

The RF tracking filters central frequency can be adjusted with the tuning word RFC_CPROG. The RF tracking filters calibration (RFCAL) consists of an internal tone at the input of the tracking filters (with the CAL PLL), and finding the RFC_CPROG corresponding to the maximum transmitted power. The RFCAL is just a little part of a more complex algorithm fully described in the flowcharts in [Section 9.4](#).

The Power detection mode is a Normal mode where the detector used for the calibrations is switched ON. This special mode enables to sense the power at the input of the TDA18211HD and makes the power scan algorithm possible (see [Section 9.4.8](#) “Flowchart TDA18211PowerScan”).

9.3.9 Description of Easy Prog byte 5

Table 18. EP5 - Easy Prog byte 5 (subaddress 07h) bit description

Legend: * power-on reset value

Bit	Symbol	Access	Value	Description
7	EXTENDED_REG	R/W		enables the extended register addressing
			1	extended register (00h to 26h)
			0*	limited register (00h to 0Fh); only 1 byte can be programmed after address 0Fh within 1 transmission
6 to 4	IR_GSTEP[2:0]	R/W	011*	gain step for image rejection calibration
3	-	R/W	0*	must be set to logic 0
2 to 0	IR_MEAS[2:0]	R/W	000*	image rejection measurement frequency range (see Table 51)

9.3.10 Description of Cal Post-Divider byte

Table 19. CPD - Cal Post-Divider byte (subaddress 08h) bit description

Legend: * power-on reset value

Bit	Symbol	Access	Value	Description
7 to 0	CAL_POST_DIV[7:0]	R/W	00h*	calibration synthesizer post-divider (see Table 46)

9.3.11 Description of Cal divider bytes 1, 2 and 3

Table 20. CD1, CD2 and CD3 - Cal divider bytes 1, 2 and 3 (address 09h, 0Ah and 0Bh) bit description

Legend: * power-on reset value

Address	Register	Bit	Symbol	Access	Value	Description
09h	CD1	7	-	R/W	0*	must be set to logic 0
		6 to 0	CAL_DIV[22:16]	R/W	00h*	calibration synthesizer main divider bits
0Ah	CD2	7 to 0	CAL_DIV[15:8]	R/W	00h*	
0Bh	CD3	7 to 0	CAL_DIV[7:0]	R/W	00h*	

9.3.12 Description of Main Post-Divider byte

Table 21. MPD - Main Post-Divider byte (subaddress 0Ch) bit description

Legend: * power-on reset value

Bit	Symbol	Access	Value	Description
7	IF_NOTCH	R/W	0*	adds a DC notch in IF for a better adjacent channels rejection; depends on standards; see Table 41
6 to 4	MAIN_POST_DIV[6:4]	R/W	000*	LO synthesizer post-divider (see Table 45)
3	DCDC_CKSW	R/W		allows switching between 16 MHz and sub-harmonic LO for DC-to-DC converter locking
			1	16 MHz
			0*	sub-harmonic LO
2 to 0	MAIN_POST_DIV[2:0]	R/W	000*	LO synthesizer post-divider (see Table 45)

9.3.13 Description of Main divider bytes 1, 2 and 3

Table 22. MD1, MD2 and MD3 - Main divider bytes 1, 2 and 3 (address 0Dh, 0Eh and 0Fh) bit description

Legend: * power-on reset value

Address	Register	Bit	Symbol	Access	Value	Description
0Dh	MD1	7	-	R/W	0*	must be set to logic 0
		6 to 0	MAIN_DIV[22:16]	R/W	00h*	LO synthesizer main divider bits
0Eh	MD2	7 to 0	MAIN_DIV[15:8]	R/W	00h*	
0Fh	MD3	7 to 0	MAIN_DIV[7:0]	R/W	00h*	

9.3.14 Description of Extended bytes 1 to 23

Table 23. EB1 to EB23 - Extended bytes 1 to 23 (address 10h to 26h) bit description

Legend: * power-on reset value

Address	Register	Bit	Symbol	Access	Value	Description	
10h	EB1	7 to 3	EB1[7:3]	R	1 1111*	extended byte 1	
		2	CALVCO_FORLON	R		determines VCO used during Normal mode operations	
						1*	LO VCO is used
						0	CAL VCO is used
		1	AGC1_ALWAYS_MASTERN	R		enables AGC1 normal operation whatever the tuner type, master or slave.	
						1*	normal operation for the master; 6 dB fixed for the slave
						0	normal operation for both the master and the slave
		0	AGC1_FIRSTN	R		determines which AGC will be updated when detectors 1 and 2 are up	
						1*	AGC1 and AGC2 both updated
						0	AGC1 has priority on AGC2
11h	EB2	7 to 0	EB2[7:0]	R/W	0000 0001*	extended byte 2	
12h	EB3	7 to 0	EB3[7:0]	R/W	1000 0100*	extended byte 3	
13h	EB4	7 to 6	EB4[7:6]	R/W	01*	extended byte 4	
		5	LO_FORCESRCE	R/W	1	forces the main PLL charge pump to source current to the main PLL loop filter	
						0*	no force
		4 to 0	EB4[4:0]	R/W	0 0001*	extended byte 4	
14h	EB5	7 and 6	EB5[7:0]	R/W	0000 0001*	extended byte 5	
15h	EB6	7 to 0	EB6[7:0]	R/W	1000 0100*	extended byte 6	
16h	EB7	7 and 6	EB7[7:6]	R/W	01*	extended byte 7	
		5	CAL_FORCESRCE	R/W	1	forces the main PLL charge pump to source current to the main PLL loop filter	
						0*	no force
		4 to 0	EB7[4:0]	R/W	0 1000*	extended byte 7	
17h	EB8	7	CID_ALARM	R		signal sensed by the power detector used during calibrations	
						1	out of range
						0*	in range
		6 to 4	EB8[6:4]	R/W	111*	extended byte 8	
		3	EB8[3]	R	0*		
		2 to 0	EB8[2:0]	R/W	101*		
18h	EB9	7 to 0	EB9[7:0]	W	0000 0000*	extended byte 9	
19h	EB10	7 and 6	EB10[7:6]	R	XX	extended byte 10	
		5 to 0	CID_GAIN[5:0]	R	XX XXXX	calibration power detector output	

Table 23. EB1 to EB23 - Extended bytes 1 to 23 (address 10h to 26h) bit description ...continued

Legend: * power-on reset value

Address	Register	Bit	Symbol	Access	Value	Description
1Ah	EB11	7 to 0	EB11[7:0]	R/W	1000 0110*	extended byte 11
1Bh	EB12	7 and 6	EB12[7:6]	R	00*	extended byte 12
		5	PD_AGC1_DET	R/W		AGC1 detector
					1	power-down
					0*	no power-down
		4	PD_AGC2_DET	R/W		AGC2 detector
					1	power-down
0*	no power-down					
		3 to 0	EB12[3:0]	R/W	0111*	extended byte 12
1Ch	EB13	7	EB13[7]	R/W	1*	extended byte 13
		6 to 4	RFC_K[2:0]	R/W	100*	parameters used during the RF tracking filters calibration (see Table 44)
		3 and 2	RFC_M[1:0]	R/W	00*	
		1 to 0	EB13[1:0]	R/W	10*	extended byte 13
1Dh	EB14	7 to 0	RFC_CPROG[7:0]	R/W	0000 0000*	tuning word of the RF tracking filters
1Eh	EB15	7 to 4	EB15[7:4]	R/W	1000*	extended byte 15
		3 to 0	EB15[3:0]	R	XXXX*	
1Fh	EB16	7 to 0	EB16[7:0]	W	000X XX00*	extended byte 16
20h	EB17	7 to 0	EB17[7:0]	W	000X XXXX*	extended byte 17
21h	EB18	7	AGC1_LOOP_OFF	R/W		turns the AGC1 loop
					1	off
					0*	on
		6 to 2	EB18[6:2]	R/W	000 00*	extended byte 18
		1 and 0	AGC1_GAIN[1:0]	R/W		AGC1 gain
					00*	6 dB
					01	9 dB
10	12 dB					
					11	15 dB
22h	EB19	7 to 0	EB19[7:0]	W	000X XX00*	extended byte 19
23h	EB20	7 and 6	EB20[7:6]	W	10*	extended byte 20
		5	FORCE_LOCK	W		forces the internal lock indicator
					1	forced to logic 1
					0*	not forced
4 to 0	EB20[4:0]	W	X XXXX*	extended byte 20		

Table 23. EB1 to EB23 - Extended bytes 1 to 23 (address 10h to 26h) bit description ...continued

Legend: * power-on reset value

Address	Register	Bit	Symbol	Access	Value	Description
24h	EB21	7	AGC2_LOOP_OFF	R/W	1	turns the AGC2 loop off
					0*	turns the AGC2 loop on
		6 to 2	EB21[6:2]	R/W	0 1100*	extended byte 21
		1 and 0	AGC2_GAIN[1:0]	R/W		AGC2 gain
	00				-15 dB	
	01				-12 dB	
	10				-9 dB	
				11*	-6 dB	
25h	EB22	7	EB22[7]	R	0*	extended byte 22
		6 to 4	RFAGC_TOP[2:0]	R/W	100*	take over point of the RF AGC, detection in RF
		3 to 0	IFAGC_TOP[3:0]	R/W	1000*	take over point of the RF AGC, detection in IF
26h	EB23	7 to 3	EB23[7:3]	R/W	1 0110*	extended byte 23
		2	FORCELP_FC2_EN	R/W	0*	1.5 MHz bandwidth filter selection; see Table 24
		1	LP_FC[2]	R/W	0*	
		0	EB23[0]	R/W	0*	extended byte 23

Table 24. Low pass cut-off frequency

FORCELP_FC2_EN	LP_FC[2]	STD[1:0]	Cut-off frequency (MHz)
0	X	00	6
0	X	01	7
0	X	10	8
0	X	11	9

9.4 I²C-bus programming flowcharts

The following flowcharts describe how to:

- Initialize the TDA18211HD
- Launch the calibrations
- Go to Normal mode

The image rejection calibration as well as RF tracking filters calibration must be launched the way explicitly described in the flowchart. If not done this way, it may result in bad calibration or even blocking the TDA18211HD, which makes it impossible to communicate via the I²C-bus.

For proper internal initialization, switching to Normal mode also requires a single I²C-bus sequence from subaddresses 03h to 0Fh.

9.4.1 Flowchart explanation

This section provides instructions for reading the flowcharts.

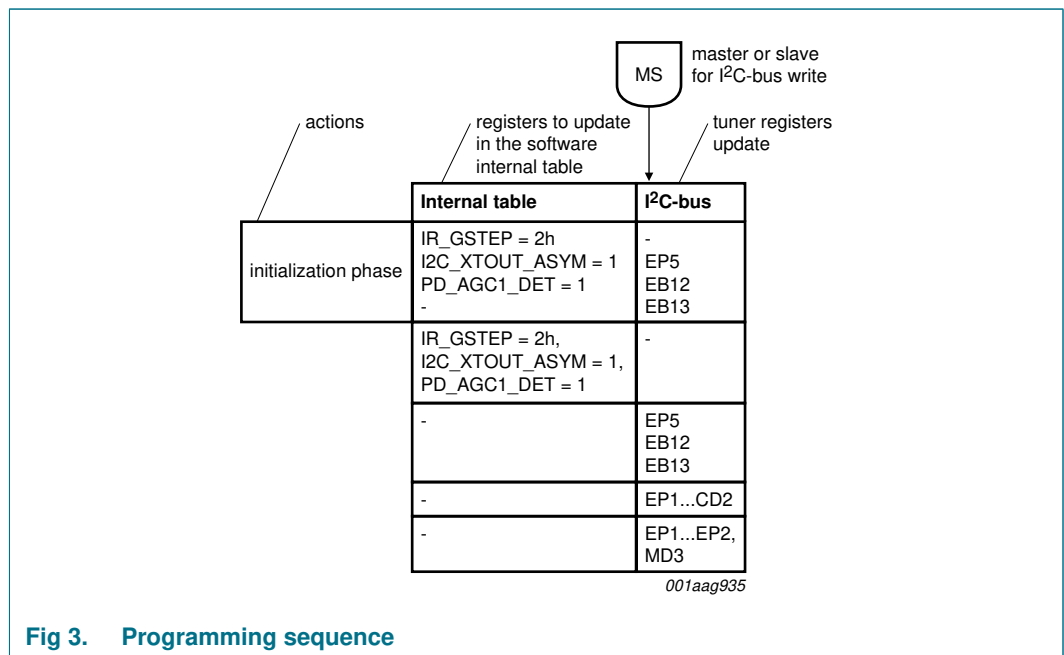

Fig 3. Programming sequence

1. I²C-bus write:

- IR_GSTEP is updated, no immediate I²C-bus write
- I2C_XTOUT_ASYM is updated followed by an I²C-bus write of EP5
- PD_AGC1_DET is updated followed by an I²C-bus write of EB12
- I²C-bus write of EB13 with current value of the software internal table of EB13

I²C-bus read:

- Sub-addressing is not supported in read mode
- The only recommended I²C-bus read access procedures of the TDA18211HD are described in [Section 9.4.16 "Flowchart TDA18211Read"](#) and [Section 9.4.17 "Flowchart TDA18211ReadExtended"](#)

2. Update at the same moment is indicated by separation with commas:
 IR_GSTEP, I2C_XTOUT_ASYM and PD_AGC1_DET are updated, no I²C-bus registers update
3. I²C-bus registers update of the bytes EP5, EB12 and EB13
4. Bytes EP1 to CD2 are written in a single I²C-bus sequence
 Example:
 Start C0 03 EP1 EP2 EP3 EP4 EP5 CPD CD1 CD2 Stop
5. Bytes EP1, EP2 and MD3 are written in as many I²C-bus sequences as needed
 Example:
 Start C0 03 EP1 EP2 Stop
 Start C0 0F MD3 Stop

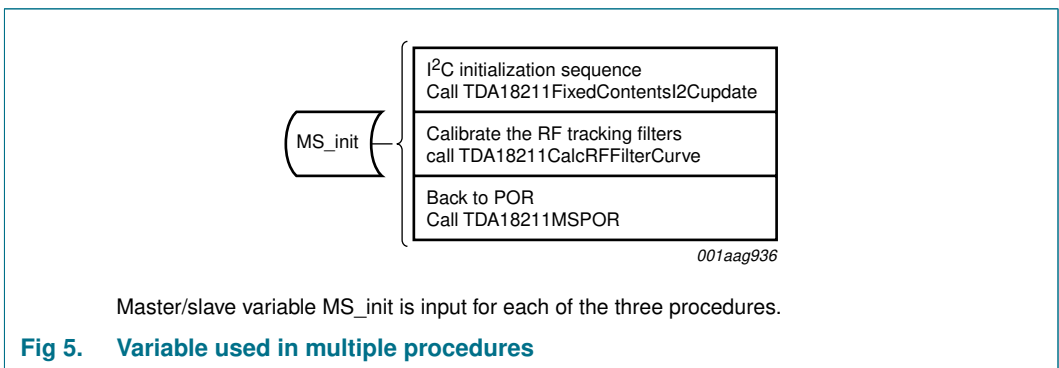
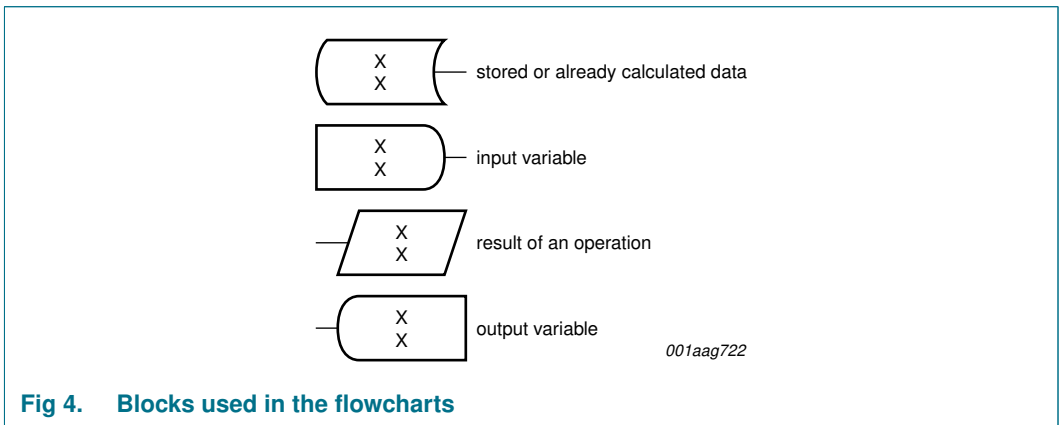

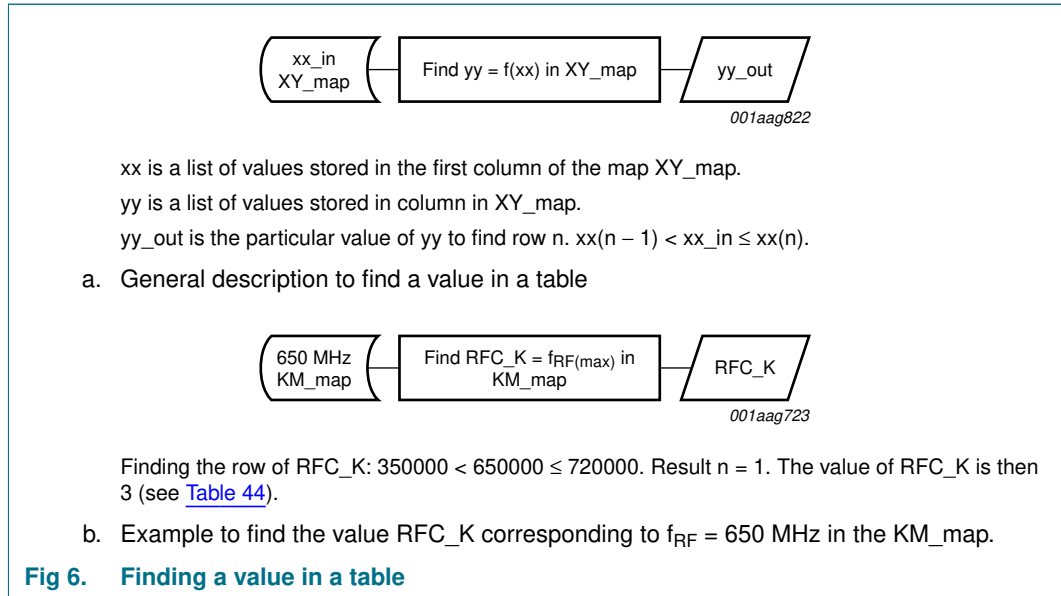

Units

- In the flowcharts, hexadecimal values end with “h”, decimal values with “d”
- Frequency variables used in computations are expressed in kHz, for example 1 GHz is written as 1000000.

9.4.2 Flowchart TDA18211SetRf_dual

Table 25. TDA18211SetRf_dual

Function	Description	Reference
Description	protocol top view for a dual-tuner application	
Input	RF_freq, Standard (from microcontroller), MS (from microcontroller)	
Table	-	
Output	-	

The initialization phase has to be launched before any SetRf.

MS = 1: master is selected for the channel configuration.

MS = 0: slave is selected for the channel configuration.

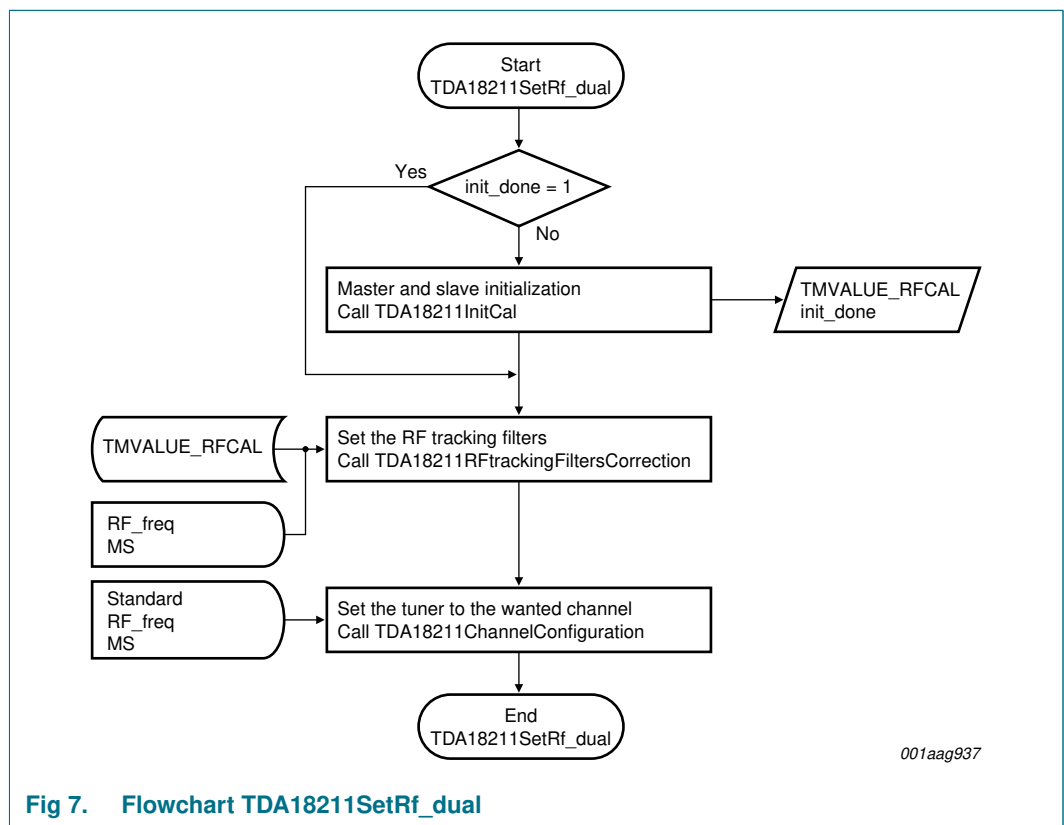

Fig 7. Flowchart TDA18211SetRf_dual