



Chipsmall Limited consists of a professional team with an average of over 10 year of expertise in the distribution of electronic components. Based in Hongkong, we have already established firm and mutual-benefit business relationships with customers from,Europe,America and south Asia,supplying obsolete and hard-to-find components to meet their specific needs.

With the principle of “Quality Parts,Customers Priority,Honest Operation,and Considerate Service”,our business mainly focus on the distribution of electronic components. Line cards we deal with include Microchip,ALPS,ROHM,Xilinx,Pulse,ON,Everlight and Freescale. Main products comprise IC,Modules,Potentiometer,IC Socket,Relay,Connector.Our parts cover such applications as commercial,industrial, and automotives areas.

We are looking forward to setting up business relationship with you and hope to provide you with the best service and solution. Let us make a better world for our industry!



Contact us

Tel: +86-755-8981 8866 Fax: +86-755-8427 6832

Email & Skype: info@chipsmall.com Web: www.chipsmall.com

Address: A1208, Overseas Decoration Building, #122 Zhenhua RD., Futian, Shenzhen, China





TDA18250BHN

Cable silicon tuner

Rev. 2 — 10 July 2013

Product short data sheet

1. General description

The TDA18250B is a silicon tuner designed specifically for worldwide cable and terrestrial digital Set Top Boxes (STB).

- The TDA18250B ensures a low system cost by saving external components such as:
 - Low-Noise Amplifiers
 - Surface Acoustic Wave (SAW) filters
 - RF splitter

Moreover, thanks to its 8 kV ESD capability, EIA/JESD22-A114 (HBM), on the RF input pin and the loop-through pin, the application level ESD protection can be reduced.

- The TDA18250B silicon tuner meets current and future digital cable and terrestrial TV reception with:
 - Low-power consumption
 - High linearity
 - Very low noise figure (3.8 dB typical)
 - High immunity to wireless interferers (WLAN, LTE and GSM)
- The TDA18250B ensures ease of use with:
 - Easy on-board integration
 - Efficient and effective PCB design
 - Reduced external components

2. Features and benefits

- Single 3.3 V supply voltage
- RF frequency coverage up to 1 GHz
- Flexible low IF output from 3 MHz to 7.5 MHz to ease the matching with various demodulators
- RoHS compliant
- I²C-bus interface compatible with 3.3 V microcontrollers
- Strong Immunity to wireless interferers (WLAN, GSM, LTE)
- Multi-reference clock frequency compliant: 16 MHz, 24 MHz, 25 MHz, 27 MHz and 30 MHz
- Crystal oscillator output buffer to drive demodulator, SoC or slave tuner
- Slave Tuner Output (STO), integrated splitter for dual tuner applications
- Fully integrated oscillators



- LT output
- Fully integrated IF and RF selectivity; eliminating the need for external SAW filters
- Single-ended RF input (no need for external balun)
- Enhanced ESD protection (8 kV HBM) on RF_IN and LT pins
- Alignment free
- Excellent return loss compatible with cable requirements
- Integrated RSSI function, readable through I²C-bus
- Integrated temperature sensor
- Integrated gain control

3. Quick reference data

Table 1. Quick reference data

Symbol	Parameter	Conditions	Min	Typ	Max	Unit
f_{RF}	RF frequency	RF input frequency range	42	-	1002	MHz
NF_{tun}	tuner noise figure	75 Ω ; maximum gain				
		$f_{RF} < 862$ MHz	-	3.8	-	dB
		$f_{RF} \geq 862$ MHz	-	4.1	-	dB
ϕ_{jit}	phase jitter	integrated from 250 Hz to 4 MHz	-	0.4	0.6	Degree
α_{image}	image rejection	IF = 5 MHz, RF (image) level ≥ 60 dB μ V	-	62	-	dB
$P_{i(max)}$	maximum input power	single channel	115	-	-	dB μ V
P	power dissipation		-	0.740	-	W

4. Ordering information

Table 2. Ordering information

Type number	Package		
	Name	Description	Version
TDA18250BHN/C1	HVQFN32	plastic thermal enhanced very thin quad flat package; no leads; 32 terminals; body 5 × 5 × 0.85 mm	SOT617-3

5. Block diagram

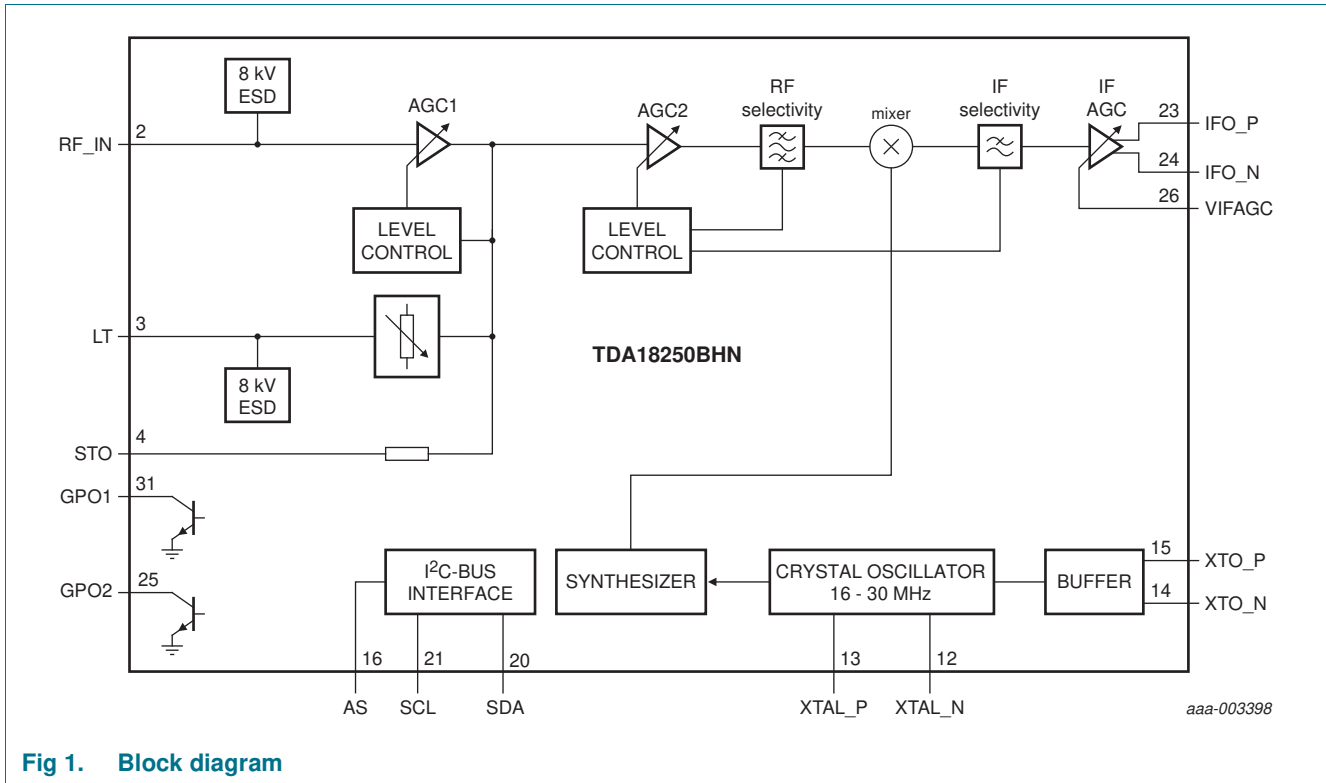

Fig 1. Block diagram

6. Limiting values

Table 3. Limiting values

In accordance with the Absolute Maximum Rating System (IEC 60134).

Symbol	Parameter	Conditions	Min	Max	Unit
V _{CC}	supply voltage		-0.3	+3.60	V
V _I	input voltage	V _{CC} < 3.3 V	-0.3	V _{CC} + 0.3	V
		V _{CC} > 3.3 V	-0.3	+3.6	V
V _{ESD}	electrostatic discharge voltage	EIA/JESD22-A114 (HBM)	2	-	kV
		EIA/JESD22-A114 (HBM); pins RF_IN and LT	8	-	kV
		EIA/JESD22-C101-C (FCDM) [1]	1	-	kV

[1] It withstands class IV of JEDEC standard.

7. Abbreviations

Table 4. Abbreviations

Acronym	Description
AGC	Automatic Gain Control
ESD	ElectroStatic Discharge
FCDM	Field Charge Device Model

Table 4. Abbreviations ...continued

Acronym	Description
GPO	General Purpose Outputs
HBM	Human Body Model
IC	Integrated Circuit
IF	Intermediate Frequency
JEDEC	Joint Electron Device Engineering Council
LT	Loop-Through
LTE	Long-Term Evolution
PCB	Printed-Circuit Board
RF	Radio Frequency
RoHS	Restriction of Hazardous Substances
RSSI	Received Signal Strength Indicator
SAW	Surface Acoustic Wave
SCL	Serial CLock
SDA	Serial DATA
SoC	System on Chip
STB	Set Top Box
STO	Slave Tuner Output
WLAN	Wireless Local Area Network
Xtal	Crystal

8. Revision history

Table 5. Revision history

Document ID	Release date	Data sheet status	Change notice	Supersedes
TDA18250BHN_SDS v.2 ^[1]	20130710	Product short data sheet	-	-

[1] Revisions 1 is not available.

9. Legal information

9.1 Data sheet status

Document status ^{[1][2]}	Product status ^[3]	Definition
Objective [short] data sheet	Development	This document contains data from the objective specification for product development.
Preliminary [short] data sheet	Qualification	This document contains data from the preliminary specification.
Product [short] data sheet	Production	This document contains the product specification.

[1] Please consult the most recently issued document before initiating or completing a design.

[2] The term 'short data sheet' is explained in section "Definitions".

[3] The product status of device(s) described in this document may have changed since this document was published and may differ in case of multiple devices. The latest product status information is available on the Internet at URL <http://www.nxp.com>.

9.2 Definitions

Draft — The document is a draft version only. The content is still under internal review and subject to formal approval, which may result in modifications or additions. NXP Semiconductors does not give any representations or warranties as to the accuracy or completeness of information included herein and shall have no liability for the consequences of use of such information.

Short data sheet — A short data sheet is an extract from a full data sheet with the same product type number(s) and title. A short data sheet is intended for quick reference only and should not be relied upon to contain detailed and full information. For detailed and full information see the relevant full data sheet, which is available on request via the local NXP Semiconductors sales office. In case of any inconsistency or conflict with the short data sheet, the full data sheet shall prevail.

Product specification — The information and data provided in a Product data sheet shall define the specification of the product as agreed between NXP Semiconductors and its customer, unless NXP Semiconductors and customer have explicitly agreed otherwise in writing. In no event however, shall an agreement be valid in which the NXP Semiconductors product is deemed to offer functions and qualities beyond those described in the Product data sheet.

9.3 Disclaimers

Limited warranty and liability — Information in this document is believed to be accurate and reliable. However, NXP Semiconductors does not give any representations or warranties, expressed or implied, as to the accuracy or completeness of such information and shall have no liability for the consequences of use of such information. NXP Semiconductors takes no responsibility for the content in this document if provided by an information source outside of NXP Semiconductors.

In no event shall NXP Semiconductors be liable for any indirect, incidental, punitive, special or consequential damages (including - without limitation - lost profits, lost savings, business interruption, costs related to the removal or replacement of any products or rework charges) whether or not such damages are based on tort (including negligence), warranty, breach of contract or any other legal theory.

Notwithstanding any damages that customer might incur for any reason whatsoever, NXP Semiconductors' aggregate and cumulative liability towards customer for the products described herein shall be limited in accordance with the *Terms and conditions of commercial sale* of NXP Semiconductors.

Right to make changes — NXP Semiconductors reserves the right to make changes to information published in this document, including without limitation specifications and product descriptions, at any time and without notice. This document supersedes and replaces all information supplied prior to the publication hereof.

Suitability for use — NXP Semiconductors products are not designed, authorized or warranted to be suitable for use in life support, life-critical or safety-critical systems or equipment, nor in applications where failure or malfunction of an NXP Semiconductors product can reasonably be expected to result in personal injury, death or severe property or environmental damage. NXP Semiconductors and its suppliers accept no liability for inclusion and/or use of NXP Semiconductors products in such equipment or applications and therefore such inclusion and/or use is at the customer's own risk.

Applications — Applications that are described herein for any of these products are for illustrative purposes only. NXP Semiconductors makes no representation or warranty that such applications will be suitable for the specified use without further testing or modification.

Customers are responsible for the design and operation of their applications and products using NXP Semiconductors products, and NXP Semiconductors accepts no liability for any assistance with applications or customer product design. It is customer's sole responsibility to determine whether the NXP Semiconductors product is suitable and fit for the customer's applications and products planned, as well as for the planned application and use of customer's third party customer(s). Customers should provide appropriate design and operating safeguards to minimize the risks associated with their applications and products.

NXP Semiconductors does not accept any liability related to any default, damage, costs or problem which is based on any weakness or default in the customer's applications or products, or the application or use by customer's third party customer(s). Customer is responsible for doing all necessary testing for the customer's applications and products using NXP Semiconductors products in order to avoid a default of the applications and the products or of the application or use by customer's third party customer(s). NXP does not accept any liability in this respect.

Limiting values — Stress above one or more limiting values (as defined in the Absolute Maximum Ratings System of IEC 60134) will cause permanent damage to the device. Limiting values are stress ratings only and (proper) operation of the device at these or any other conditions above those given in the Recommended operating conditions section (if present) or the Characteristics sections of this document is not warranted. Constant or repeated exposure to limiting values will permanently and irreversibly affect the quality and reliability of the device.

Terms and conditions of commercial sale — NXP Semiconductors products are sold subject to the general terms and conditions of commercial sale, as published at <http://www.nxp.com/profile/terms>, unless otherwise agreed in a valid written individual agreement. In case an individual agreement is concluded only the terms and conditions of the respective agreement shall apply. NXP Semiconductors hereby expressly objects to applying the customer's general terms and conditions with regard to the purchase of NXP Semiconductors products by customer.

No offer to sell or license — Nothing in this document may be interpreted or construed as an offer to sell products that is open for acceptance or the grant, conveyance or implication of any license under any copyrights, patents or other industrial or intellectual property rights.

Export control — This document as well as the item(s) described herein may be subject to export control regulations. Export might require a prior authorization from competent authorities.

Quick reference data — The Quick reference data is an extract of the product data given in the Limiting values and Characteristics sections of this document, and as such is not complete, exhaustive or legally binding.

Non-automotive qualified products — Unless this data sheet expressly states that this specific NXP Semiconductors product is automotive qualified, the product is not suitable for automotive use. It is neither qualified nor tested in accordance with automotive testing or application requirements. NXP Semiconductors accepts no liability for inclusion and/or use of non-automotive qualified products in automotive equipment or applications.

In the event that customer uses the product for design-in and use in automotive applications to automotive specifications and standards, customer (a) shall use the product without NXP Semiconductors' warranty of the product for such automotive applications, use and specifications, and (b) whenever customer uses the product for automotive applications beyond NXP Semiconductors' specifications such use shall be solely at customer's own risk, and (c) customer fully indemnifies NXP Semiconductors for any liability, damages or failed product claims resulting from customer design and use of the product for automotive applications beyond NXP Semiconductors' standard warranty and NXP Semiconductors' product specifications.

Translations — A non-English (translated) version of a document is for reference only. The English version shall prevail in case of any discrepancy between the translated and English versions.

9.4 Licenses

ICs with DVB-T or DVB-T2 functionality

Use of this product in any manner that complies with the DVB-T or the DVB-T2 standard may require licenses under applicable patents of the DVB-T respectively the DVB-T2 patent portfolio, which license is available from Sisvel S.p.A., Via Sestriere 100, 10060 None (TO), Italy, and under applicable patents of other parties.

9.5 Trademarks

Notice: All referenced brands, product names, service names and trademarks are the property of their respective owners.

I²C-bus — logo is a trademark of NXP B.V.

10. Contact information

For more information, please visit: <http://www.nxp.com>

For sales office addresses, please send an email to: salesaddresses@nxp.com

11. Tables

Table 1. Quick reference data	2	Table 4. Abbreviations	3
Table 2. Ordering information	2	Table 5. Revision history	4
Table 3. Limiting values	3		

12. Figures

Fig 1. Block diagram	3
----------------------------	---

13. Contents

1	General description	1
2	Features and benefits	1
3	Quick reference data	2
4	Ordering information	2
5	Block diagram	3
6	Limiting values	3
7	Abbreviations	3
8	Revision history	4
9	Legal information	5
9.1	Data sheet status	5
9.2	Definitions	5
9.3	Disclaimers	5
9.4	Licenses	6
9.5	Trademarks	6
10	Contact information	6
11	Tables	7
12	Figures	7
13	Contents	8

Please be aware that important notices concerning this document and the product(s) described herein, have been included in section 'Legal information'.

© NXP B.V. 2013.

All rights reserved.

For more information, please visit: <http://www.nxp.com>

For sales office addresses, please send an email to: salesaddresses@nxp.com

Date of release: 10 July 2013

Document identifier: TDA18250BHN_SDS