



Chipsmall Limited consists of a professional team with an average of over 10 year of expertise in the distribution of electronic components. Based in Hongkong, we have already established firm and mutual-benefit business relationships with customers from,Europe,America and south Asia,supplying obsolete and hard-to-find components to meet their specific needs.

With the principle of “Quality Parts,Customers Priority,Honest Operation,and Considerate Service”,our business mainly focus on the distribution of electronic components. Line cards we deal with include Microchip,ALPS,ROHM,Xilinx,Pulse,ON,Everlight and Freescale. Main products comprise IC,Modules,Potentiometer,IC Socket,Relay,Connector.Our parts cover such applications as commercial,industrial, and automotives areas.

We are looking forward to setting up business relationship with you and hope to provide you with the best service and solution. Let us make a better world for our industry!



Contact us

Tel: +86-755-8981 8866 Fax: +86-755-8427 6832

Email & Skype: info@chipsmall.com Web: www.chipsmall.com

Address: A1208, Overseas Decoration Building, #122 Zhenhua RD., Futian, Shenzhen, China





TDA7231A

1.6W AUDIO AMPLIFIER

- OPERATING VOLTAGE 1.8 TO 15 V
- LOW QUIESCENT CURRENT
- HIGH POWER CAPABILITY
- LOW CROSSOVER DISTORTION
- SOFT CLIPPING

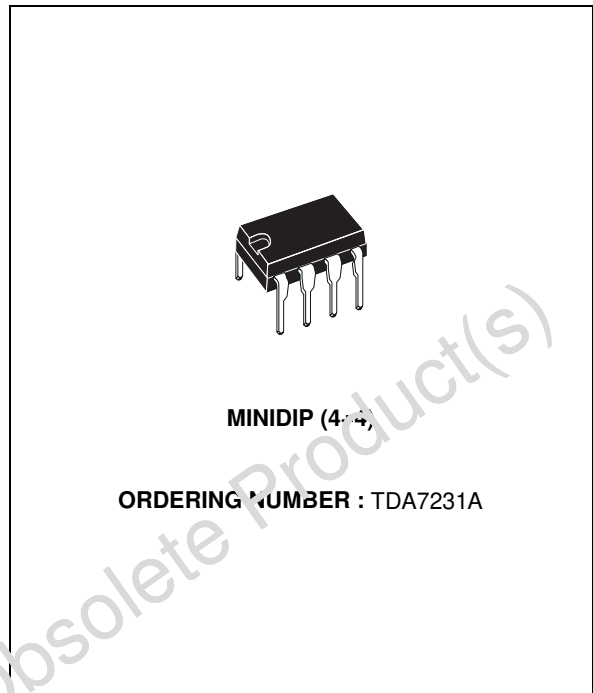

DESCRIPTION

The TDA7231A is a monolithic integrated circuit in 4 + 4 lead minidip package. It is intended for use as class AB power amplifier with wide range of supply voltage in portable radios, cassette recorders and players, etc.

PIN CONNECTION

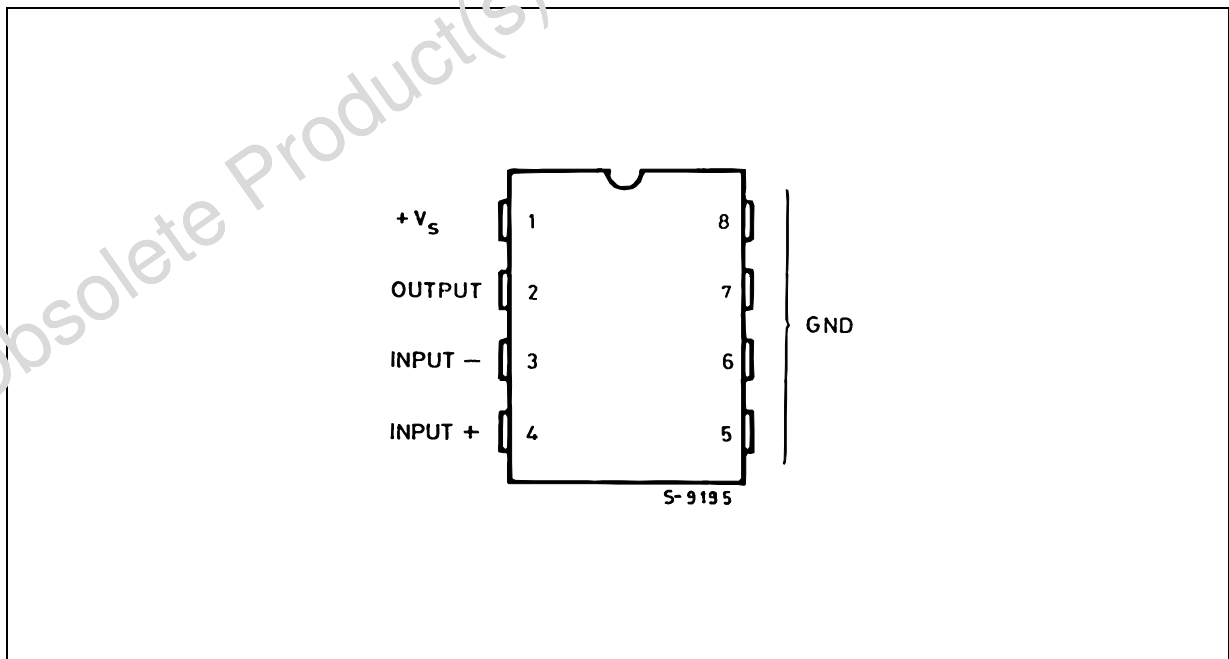

ABSOLUTE MAXIMUM RATINGS

Symbol	Parameter	Value	Unit
V_s	Supply Voltage	16	V
P_{tot}	Total Power Dissipation at $T_{amb} = 50\text{ }^\circ\text{C}$ at $T_{case} = 70\text{ }^\circ\text{C}$	1.25 4	W W
I_o	Output Peak Current	1	A
T_{stg}, T_j	Storage and Junction Temperature	- 40 to 150	$^\circ\text{C}$

THERMAL DATA

Symbol	Parameter	Value	Unit
$R_{th\ j-amb}$	Thermal Resistance Junction-ambient Max.	80	$^\circ\text{C/W}$
$R_{th\ j-pins}$	Thermal Resistance Junction-pins Max.	15	$^\circ\text{C/W}$

ELECTRICAL CHARACTERISTICS ($V_s = 6\text{ V}$, $T_{amb} = 25\text{ }^\circ\text{C}$, unless otherwise specified)

Symbol	Parameter	Test Conditions	Min.	Typ.	Max.	Unit
V_s	Supply Voltage		1.8		15	V
V_o	Quiescent Out Voltage	$V_s = 6\text{ V}$ $V_s = 3\text{ V}$		2.7 1.2		V V
I_d	Quiescent Drain Current			3.6	9	mA
I_b	Input Bias Current			100		nA
P_o	Output Power	$d = 10\%$ $f = 1\text{ kHz}$ $V_s = 12\text{ V}$ $R_L = 8\Omega$ $V_s = 9\text{ V}$ $R_L = 4\Omega$ $V_s = 6\text{ V}$ $R_L = 8\Omega$ $V_s = 6\text{ V}$ $R_L = 4\Omega$ $V_s = 3\text{ V}$ $R_L = 4\Omega$ $V_s = 3\text{ V}$ $R_L = 8\Omega$		1.8 1.6 0.4 0.7 110 70		W W W W mW mW
d	Distortion	$P_o = 0.2\text{ W}$ $f = 1\text{ kHz}$ $R_L = 8\Omega$		0.3		%
G_v	Closed Loop Voltage Gain			38		dB
R_{in}	Input Resistance	$f = 1\text{ kHz}$	100			k Ω
e_N	Total Input Noise	$R_s = 10\text{ k}\Omega$ B = Curve A B = 22Hz to 22kHz		2 3		μV μV

Figure 1 : Test and Application Circuit

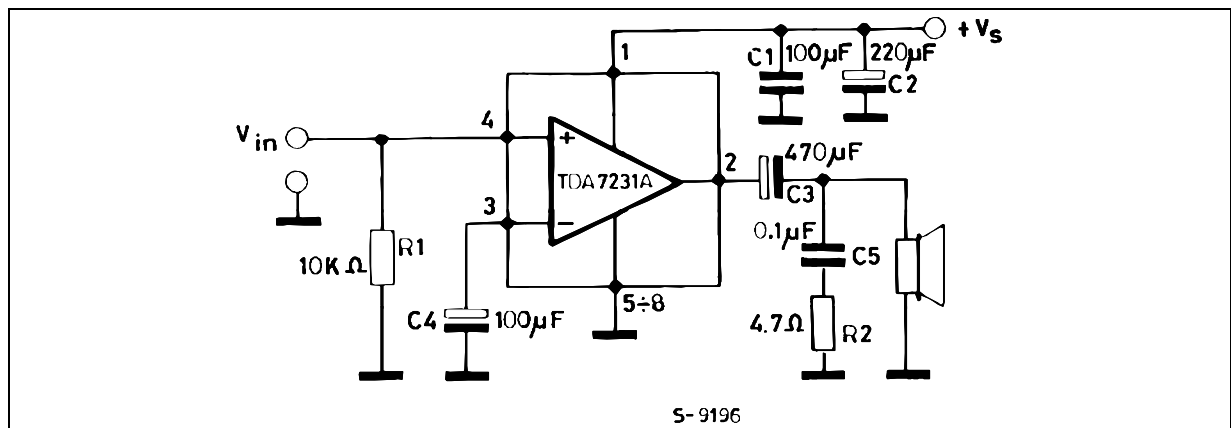

Figure 2 : P.C. Board and Components Layout of the figure 1 (1:1 scale)

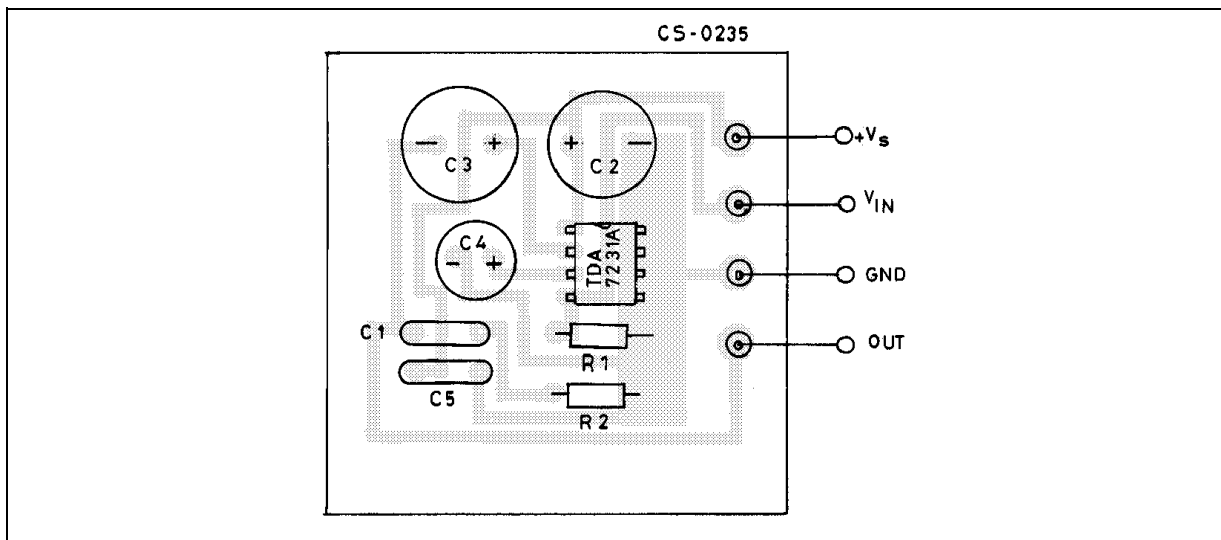

Figure 3 : Output Power versus Supply Voltage

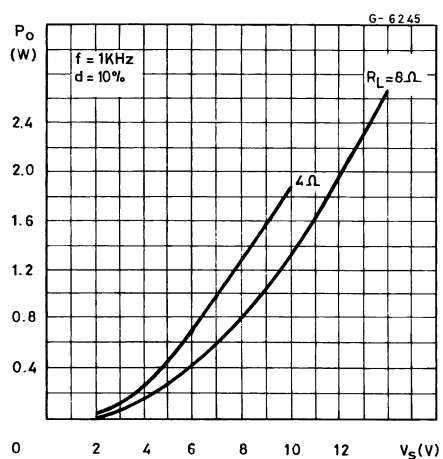

Figure 4 : Quiescent Current versus Supply Voltage

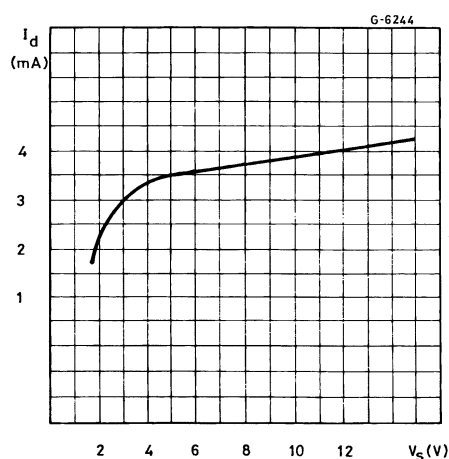

Figure 5 : Quiescent Output Voltage versus Supply Voltage

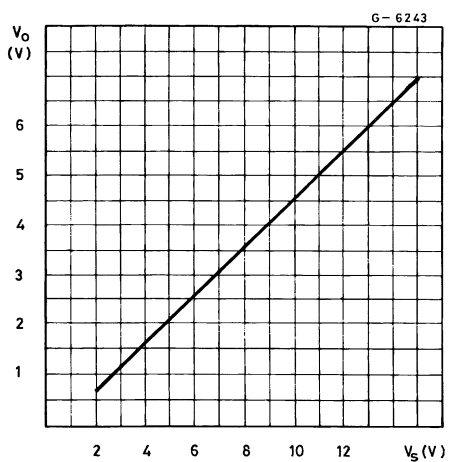
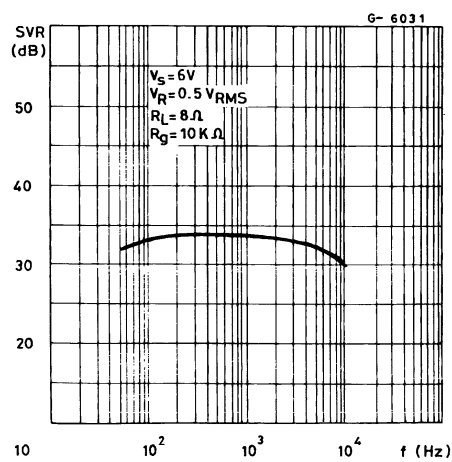
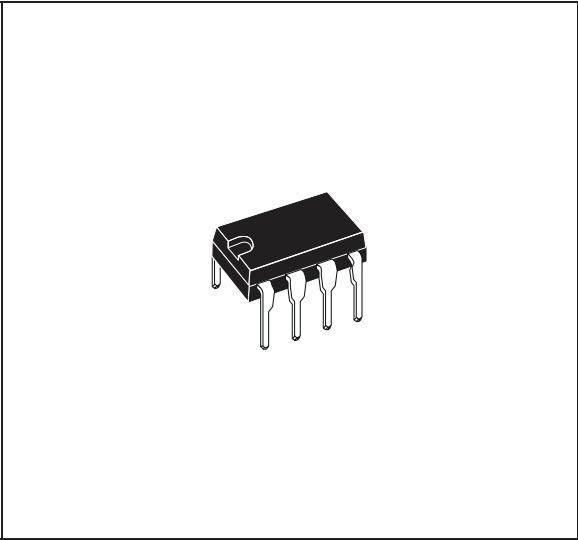

Figure 6 : Supply Voltage Rejection versus Frequency



DIM.	mm			inch		
	MIN.	TYP.	MAX.	MIN.	TYP.	MAX.
A		3.3			0.130	
a1	0.7			0.028		
B	1.39		1.65	0.055		0.065
B1	0.91		1.04	0.036		0.041
b		0.5			0.020	
b1	0.38		0.5	0.015		0.020
D			9.8			0.386
E		8.8			0.346	
e		2.54			0.100	
e3		7.62			0.300	
e4		7.62			0.300	
F			7.1			0.280
I			4.8			0.189
L		3.3			0.130	
Z	0.44		1.6	0.017		0.063

OUTLINE AND MECHANICAL DATA



PowerMinidip

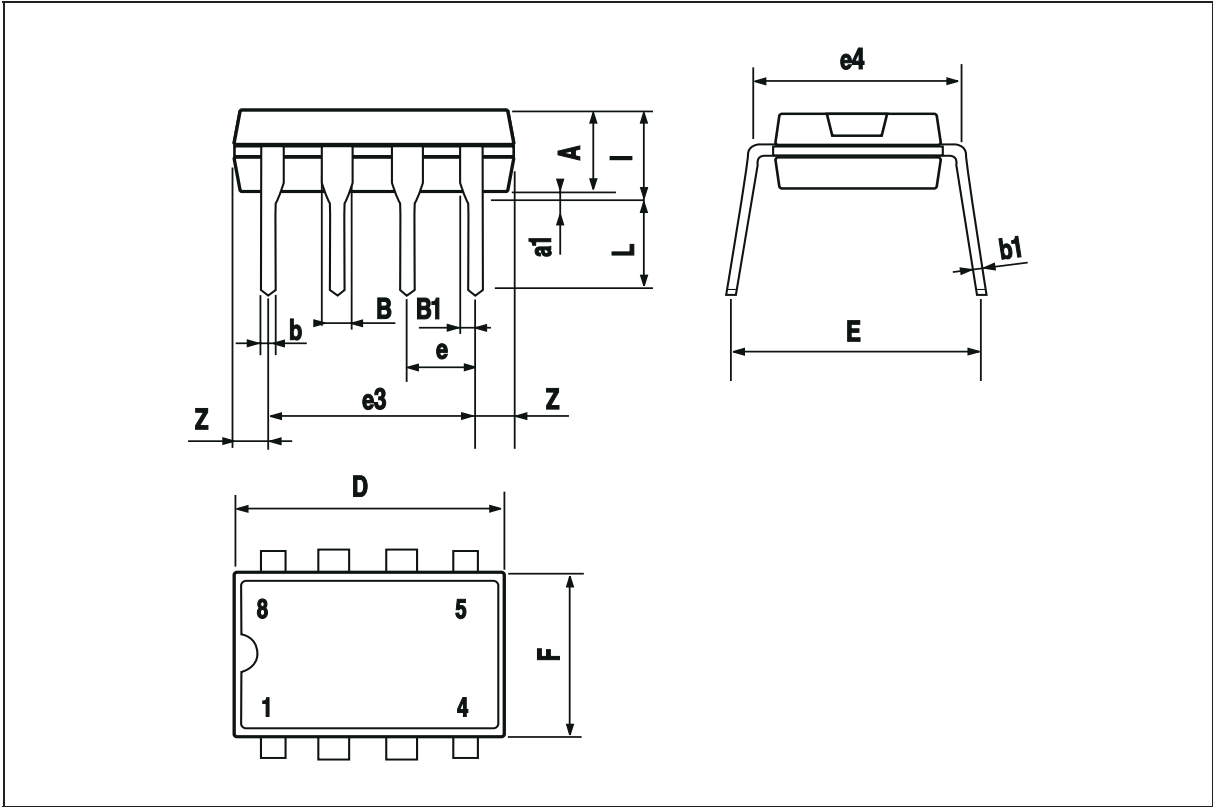

Information furnished is believed to be accurate and reliable. However, STMicroelectronics assumes no responsibility for the consequences of use of such information nor for any infringement of patents or other rights of third parties which may result from its use. No license is granted by implication or otherwise under any patent or patent rights of STMicroelectronics. Specifications mentioned in this publication are subject to change without notice. This publication supersedes and replaces all information previously supplied. STMicroelectronics products are not authorized for use as critical components in life support devices or systems without express written approval of STMicroelectronics. The ST logo is a registered trademark of STMicroelectronics.

All other names are the property of their respective owners

© 2003 STMicroelectronics - All rights reserved

STMicroelectronics GROUP OF COMPANIES

Australia – Belgium - Brazil - Canada - China – Czech Republic - Finland - France - Germany - Hong Kong - India - Israel - Italy - Japan - Malaysia - Malta - Morocco - Singapore - Spain - Sweden - Switzerland - United Kingdom - United States

www.st.com.

