



Chipsmall Limited consists of a professional team with an average of over 10 year of expertise in the distribution of electronic components. Based in Hongkong, we have already established firm and mutual-benefit business relationships with customers from,Europe,America and south Asia,supplying obsolete and hard-to-find components to meet their specific needs.

With the principle of “Quality Parts,Customers Priority,Honest Operation,and Considerate Service”,our business mainly focus on the distribution of electronic components. Line cards we deal with include Microchip,ALPS,ROHM,Xilinx,Pulse,ON,Everlight and Freescale. Main products comprise IC,Modules,Potentiometer,IC Socket,Relay,Connector.Our parts cover such applications as commercial,industrial, and automotives areas.

We are looking forward to setting up business relationship with you and hope to provide you with the best service and solution. Let us make a better world for our industry!



Contact us

Tel: +86-755-8981 8866 Fax: +86-755-8427 6832

Email & Skype: info@chipsmall.com Web: www.chipsmall.com

Address: A1208, Overseas Decoration Building, #122 Zhenhua RD., Futian, Shenzhen, China





TDA7233 TDA7233D

1W AUDIO AMPLIFIER WITH MUTE

- OPERATING VOLTAGE 1.8 TO 15V
- EXTERNAL MUTE OR POWER DOWN FUNCTION
- IMPROVED SUPPLY VOLTAGE REJECTION
- LOW QUIESCENT CURRENT
- HIGH POWER CAPABILITY
- LOW CROSSOVER DISTORTION

DESCRIPTION

The TDA7233/D is a monolithic integrated circuit in 8 pin Minidip or SO8 package, intended for use as class AB power amplifier with a wide range of supply voltage from 1.8V to 15V in portable players, cordless telephones and Cellular Radios.

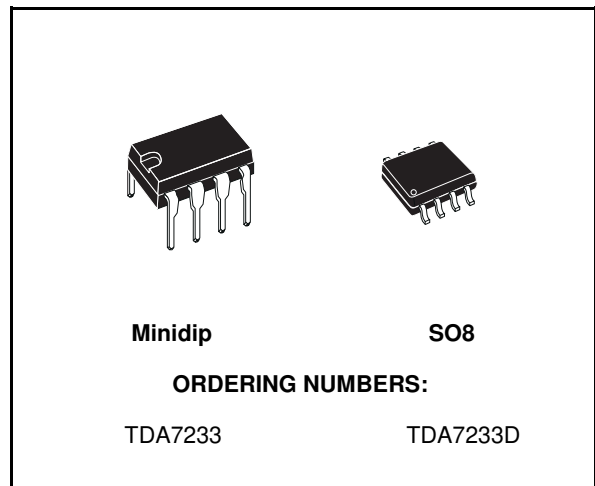

TEST AND APPLICATION CIRCUIT

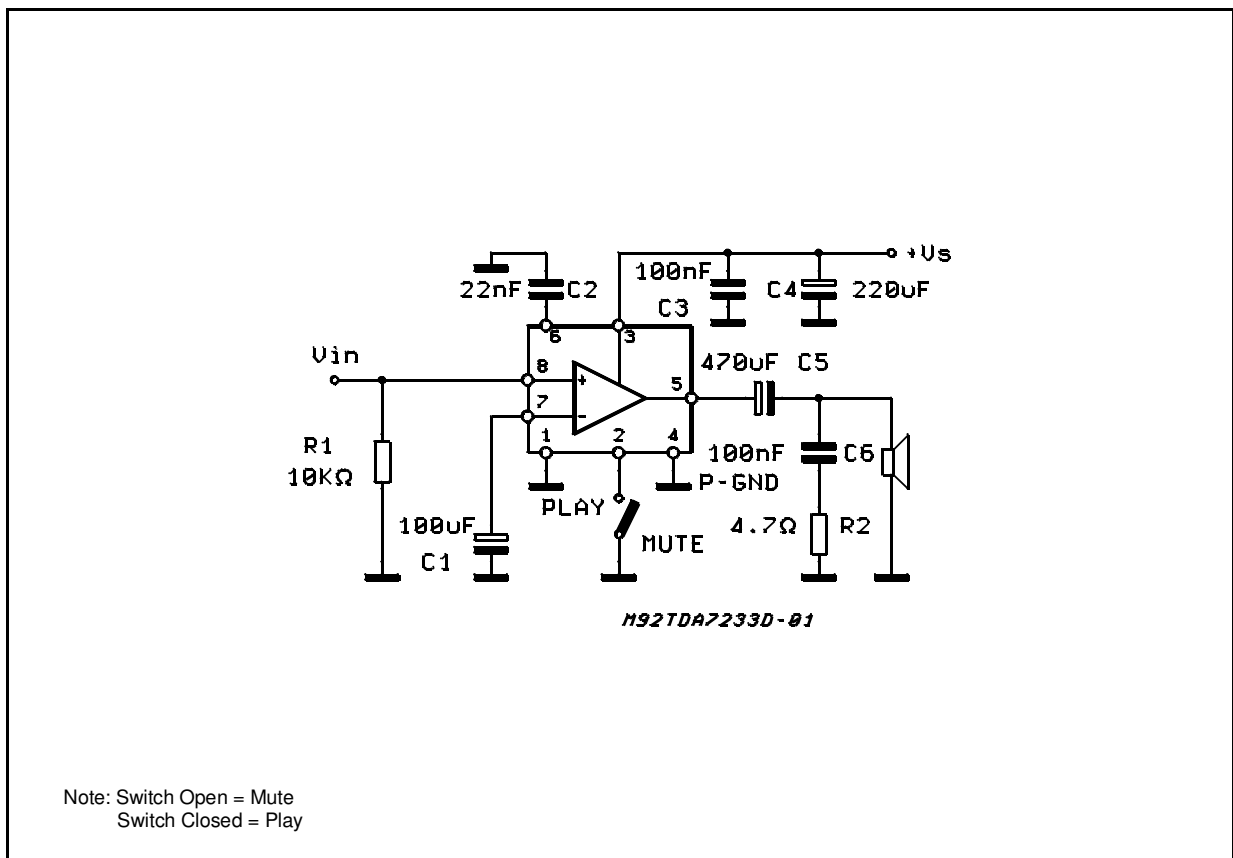

TDA7233 - TDA7233D

ABSOLUTE MAXIMUM RATINGS

Symbol	Parameter	Value	Unit
V_S	Supply Voltage	16	V
I_O	Output Peak Current	1	A
P_{tot}	Total Power Dissipation at $T_{amb} = 50^\circ\text{C}$	1	W
T_{stg}, T_j	Storage and Junction Temperature	-40 to 150	$^\circ\text{C}$

PIN CONNECTIONS (Top views)

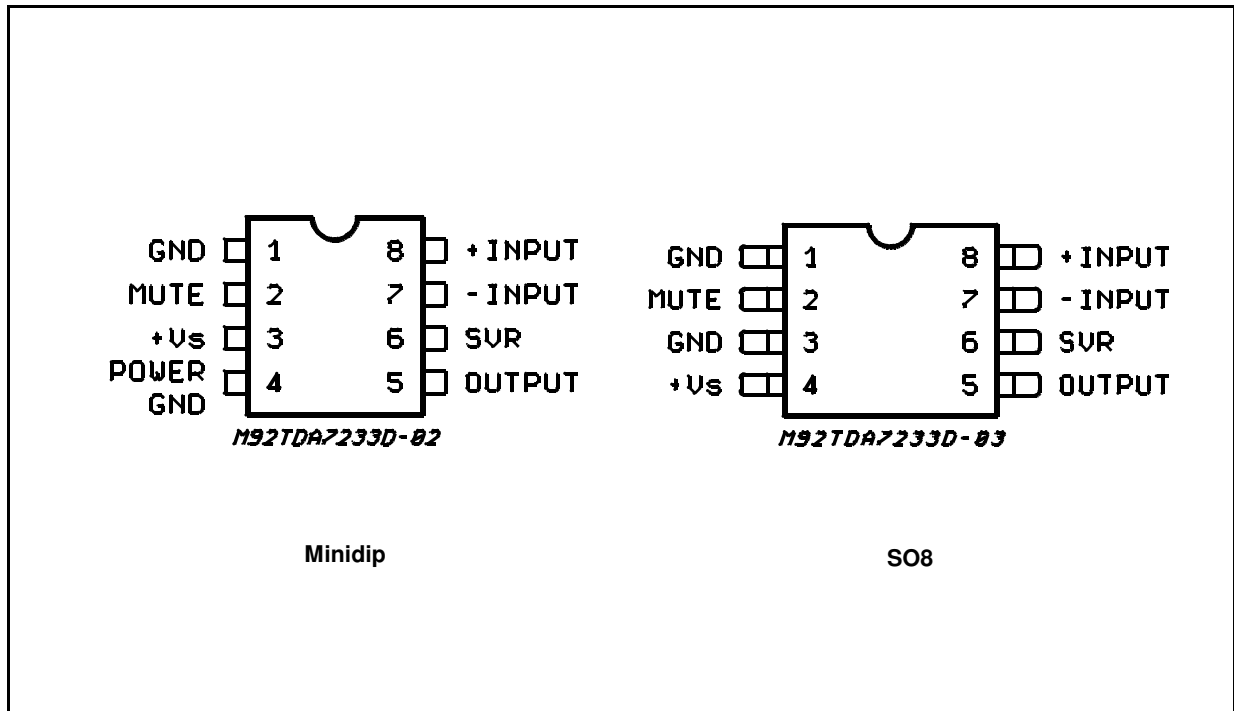

THERMAL DATA

Symbol	Parameter	Max.	SO8	Minidip	Unit
$R_{thj-amb}$	Thermal Resistance Junction-ambient	Max.	200	100	$^\circ\text{C}/\text{W}$

ELECTRICAL CHARACTERISTICS ($V_s = 6\text{ V}$, $T_{\text{amb}} = 25\text{ }^\circ\text{C}$, unless otherwise specified)

Symbol	Parameter	Test Condition	Min.	Typ.	Max.	Unit
V_s	Supply Voltage		1.8		15	V
V_o	Quiescent Out Voltage			2.7		V
		$V_s = 3\text{ V}$		1.2		V
		$V_s = 9\text{ V}$		4.2		V
I_d	Quiescent Drain Current	MUTE HIGH		3.6	9	mA
		MUTE LOW		0.4		
I_b	Input Bias Current			100		nA
P_o	Output Power	$d = 10\%$ $f = 1\text{ kHz}$ $V_s = 12\text{ V}$ $R_L = 8\ \Omega$ $V_s = 9\text{ V}$ $R_L = 4\ \Omega$ $V_s = 9\text{ V}$ $R_L = 8\ \Omega$ $V_s = 6\text{ V}$ $R_L = 8\ \Omega$ $V_s = 6\text{ V}$ $R_L = 4\ \Omega$ $V_s = 3\text{ V}$ $R_L = 4\ \Omega$ $V_s = 3\text{ V}$ $R_L = 8\ \Omega$		1.9 1.6 1 0.4 0.7 110 70		W W W W W mW mW
d	Distortion	$P_o = 0.5\text{ W}$ $f = 1\text{ kHz}$ $R_L = 8\ \Omega$ $V_s = 9\text{ V}$		0.3		%
G_v	Closed Loop Voltage Gain	$f = 1\text{ kHz}$		39		dB
R_{IN}	Input Resistance	$f = 1\text{ kHz}$	100			$\text{K}\Omega$
e_N	Total Input Noise ($R_s = 10\text{ k}\Omega$)	B = Curve A		2		μV
		B = 22 Hz to 22 kHz		3		
SVR	Supply Voltage Rejection	$f = 100\text{ Hz}$, $R_g = 10\text{ K}\Omega$		45		dB
	MUTE Attenuation	$V_o = 1\text{ V}$ $f = 100\text{ Hz to } 10\text{ kHz}$		70		dB
	MUTE Threshold			0.6		V
I_M	MUTE Current	$V_s = 15\text{ V}$		0.4		mA

Figure 1: Output Power vs. Supply Voltage

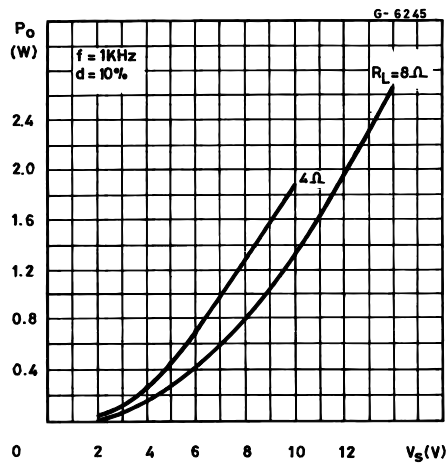

Figure 3: DC Output Voltage vs. Supply Voltage

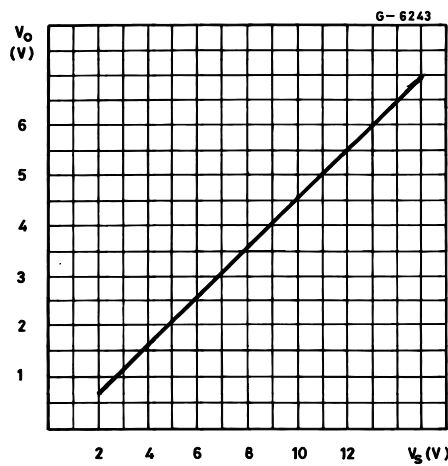

Figure 5: Total Dissipated Power vs. Supply Voltage

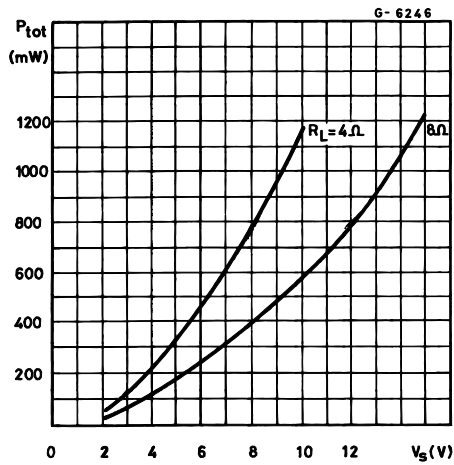

Figure 2: Supply Voltage Rejection vs. Frequency

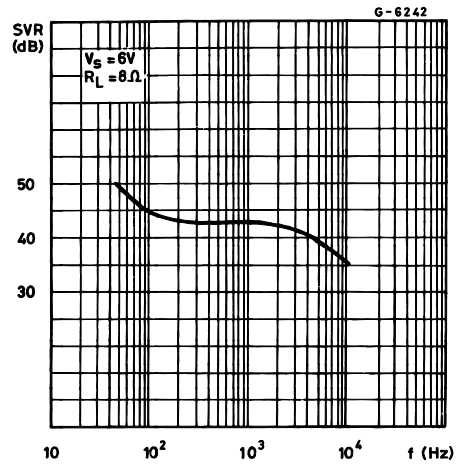
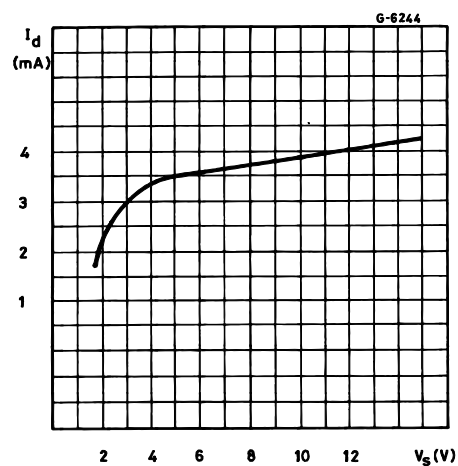
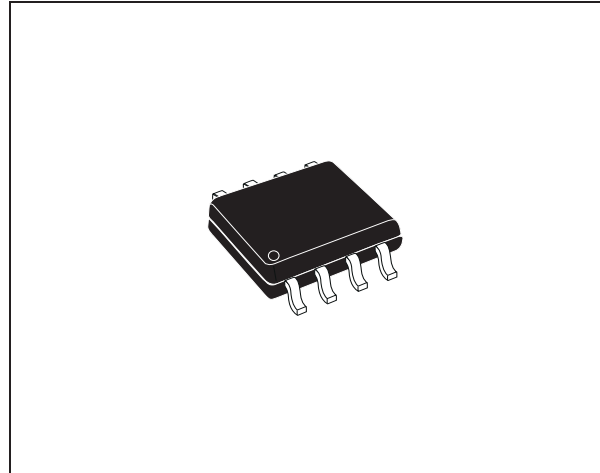

Figure 4: Quiescent Current vs. Supply Voltage



DIM.	mm			inch		
	MIN.	TYP.	MAX.	MIN.	TYP.	MAX.
A			1.75			0.069
a1	0.1		0.25	0.004		0.010
a2			1.65			0.065
a3	0.65		0.85	0.026		0.033
b	0.35		0.48	0.014		0.019
b1	0.19		0.25	0.007		0.010
C	0.25		0.5	0.010		0.020
c1	45° (typ.)					
D (1)	4.8		5.0	0.189		0.197
E	5.8		6.2	0.228		0.244
e		1.27			0.050	
e3		3.81			0.150	
F (1)	3.8		4.0	0.15		0.157
L	0.4		1.27	0.016		0.050
M			0.6			0.024
S	8° (max.)					

OUTLINE AND MECHANICAL DATA



SO8

(1) D and F do not include mold flash or protrusions. Mold flash or protrusions shall not exceed 0.15mm (.006inch).

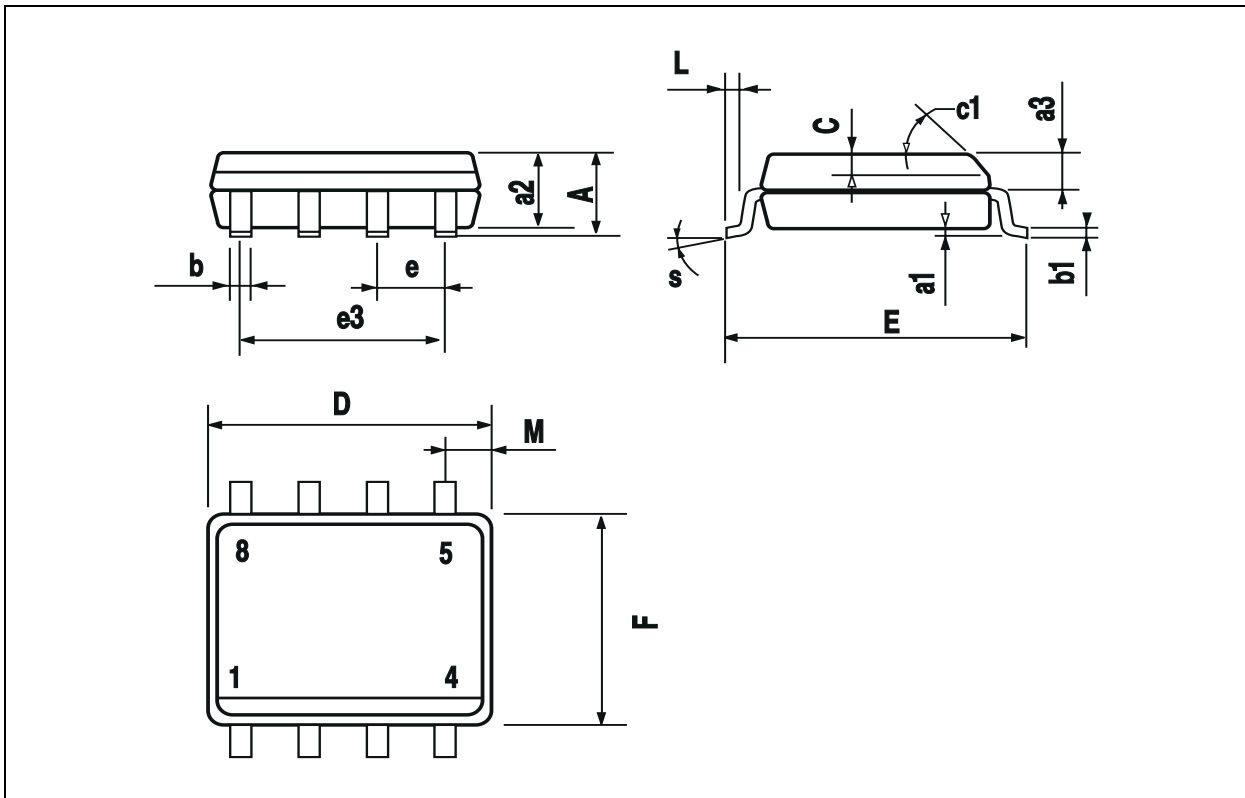

TDA7233 - TDA7233D

DIM.	mm			inch		
	MIN.	TYP.	MAX.	MIN.	TYP.	MAX.
A		3.32			0.131	
a1	0.51			0.020		
B	1.15		1.65	0.045		0.065
b	0.356		0.55	0.014		0.022
b1	0.204		0.304	0.008		0.012
D			10.92			0.430
E	7.95		9.75	0.313		0.384
e		2.54			0.100	
e3		7.62			0.300	
e4		7.62			0.300	
F			6.6			0.260
I			5.08			0.200
L	3.18		3.81	0.125		0.150
Z			1.52			0.060

OUTLINE AND MECHANICAL DATA

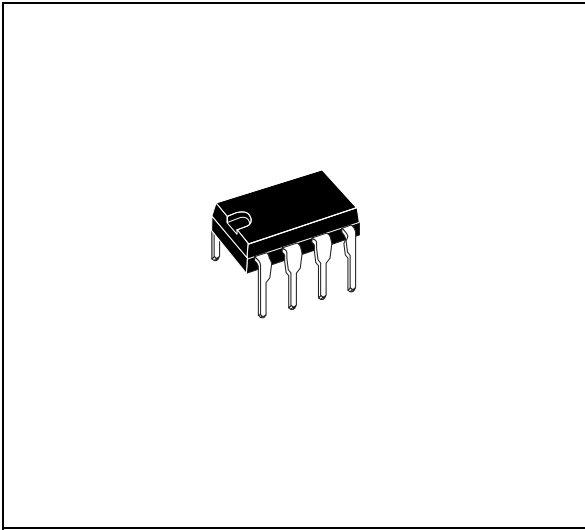

Minidip

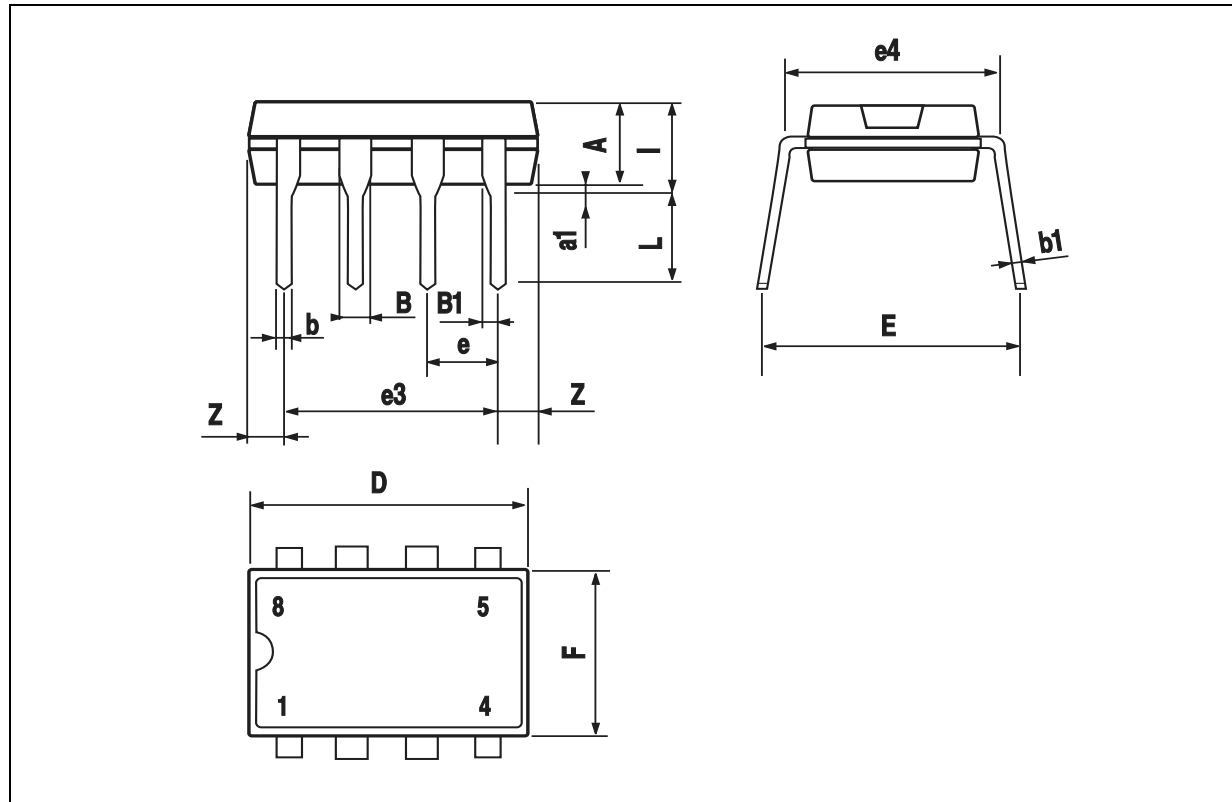

Information furnished is believed to be accurate and reliable. However, STMicroelectronics assumes no responsibility for the consequences of use of such information nor for any infringement of patents or other rights of third parties which may result from its use. No license is granted by implication or otherwise under any patent or patent rights of STMicroelectronics. Specifications mentioned in this publication are subject to change without notice. This publication supersedes and replaces all information previously supplied. STMicroelectronics products are not authorized for use as critical components in life support devices or systems without express written approval of STMicroelectronics.

The ST logo is a registered trademark of STMicroelectronics.
All other names are the property of their respective owners

© 2003 STMicroelectronics - All rights reserved

STMicroelectronics GROUP OF COMPANIES

Australia – Belgium - Brazil - Canada - China – Czech Republic - Finland - France - Germany - Hong Kong - India - Israel - Italy - Japan -
Malaysia - Malta - Morocco - Singapore - Spain - Sweden - Switzerland - United Kingdom - United States

www.st.com