



Chipsmall Limited consists of a professional team with an average of over 10 year of expertise in the distribution of electronic components. Based in Hongkong, we have already established firm and mutual-benefit business relationships with customers from,Europe,America and south Asia,supplying obsolete and hard-to-find components to meet their specific needs.

With the principle of “Quality Parts,Customers Priority,Honest Operation,and Considerate Service”,our business mainly focus on the distribution of electronic components. Line cards we deal with include Microchip,ALPS,ROHM,Xilinx,Pulse,ON,Everlight and Freescale. Main products comprise IC,Modules,Potentiometer,IC Socket,Relay,Connector.Our parts cover such applications as commercial,industrial, and automotives areas.

We are looking forward to setting up business relationship with you and hope to provide you with the best service and solution. Let us make a better world for our industry!



Contact us

Tel: +86-755-8981 8866 Fax: +86-755-8427 6832

Email & Skype: info@chipsmall.com Web: www.chipsmall.com

Address: A1208, Overseas Decoration Building, #122 Zhenhua RD., Futian, Shenzhen, China





TDA7365

2 x 6W CAR RADIO AMPLIFIER PLUS SOLID STATE SWITCH

- OUTPUT POWER 2x6W/4Ω @14.4V, 1KHz, 10%
- SOLID STATE POWER SWITCH INCLUDED (1A @ V_{DROP} = 0.8V Typ.)
- MINIMUM EXTERNAL COMPONENT COUNT
 - INTERNALLY FIXED GAIN (40dB)
 - NO BOOTSTRAP CAPACITORS
 - NO EXTERNAL COMPENSATION
- ST-BY FUNCTION (CMOS COMPATIBLE)
- MUTE FUNCTION (CMOS COMPATIBLE)
- NO AUDIBLE POP DURING MUTE/ST-BY OPERATIONS
- LOW SUPPLY SELF MUTING

PROTECTIONS

- AC AUDIO OUTPUTS SHORT CIRCUIT TO GND
- DC AUDIO OUTPUTS SHORT CIRCUIT TO GND AND TO V_s AT POWER ON
- SWITCH OUTPUT INTERNAL CURRENT LIMITATION
- OVERRATING CHIP TEMPERATURE WITH SOFT THERMAL LIMITER
- LOAD DUMP
- FORTUITOUS OPEN GND

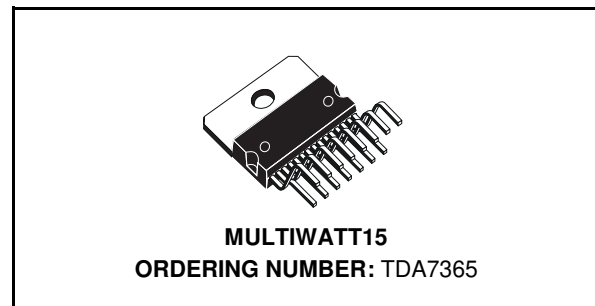

- REVERSE BATTERY
- ESD

DESCRIPTION

The TDA7365 is a new technology Dual Audio Amplifier in Multiwatt15 package especially designed for stereo car radio applications.

Thanks to the fully complementary output configuration the TDA7365 delivers a rail to rail voltage swing with no need of bootstrap capacitors. It includes a solid state switch, enabled by a ST-BY function common to the audio section, suitable for supplying both the signal processing part of the car radio set and the lamps. As a result the power-on operation is simplified, thereby saving cost and space in the whole power section.

BLOCK DIAGRAM

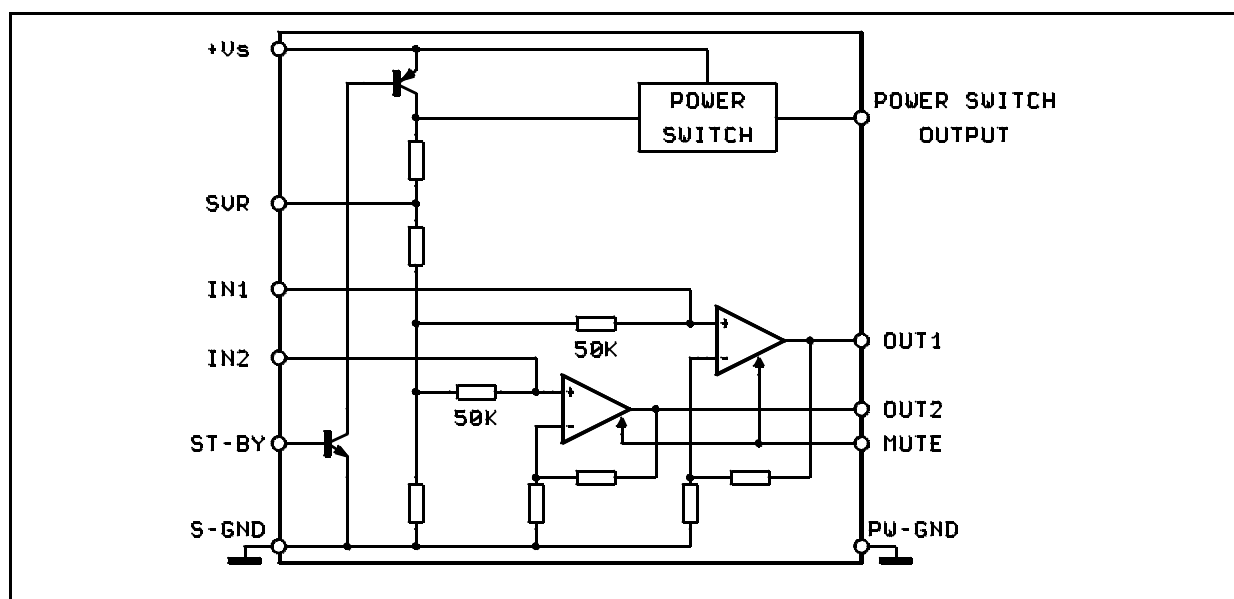

TDA7365

PIN CONNECTION (Top view)

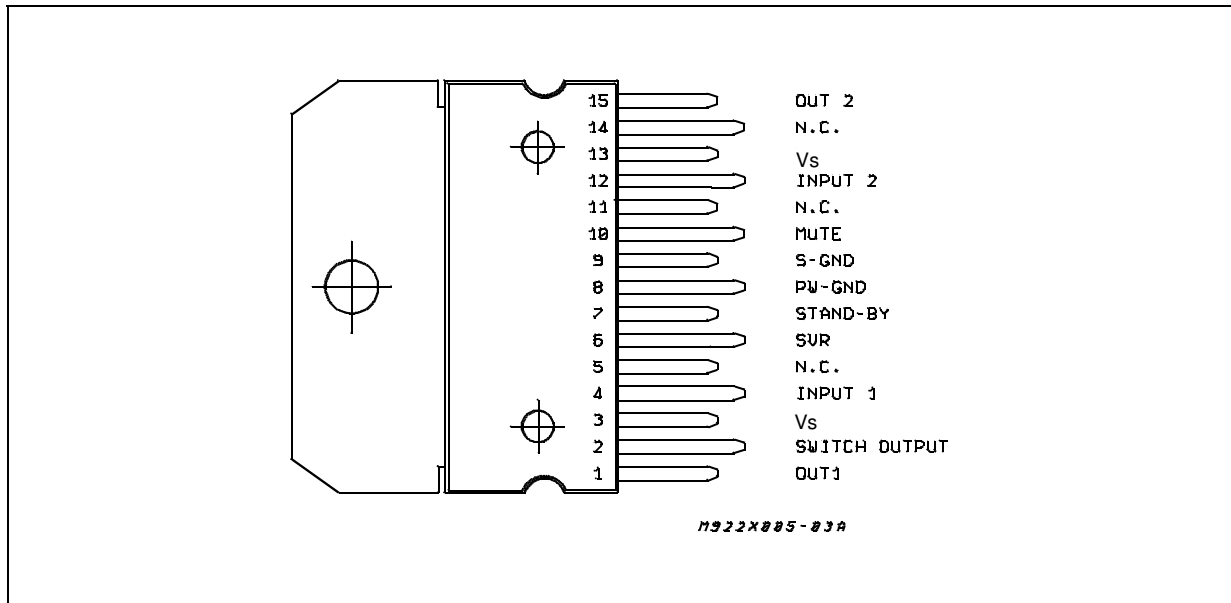

ABSOLUTE MAXIMUM RATINGS

Symbol	Parameter	Value	Unit
V_S	DC Supply Voltage	28	V
V_{OP}	Operating Supply Voltage	18	V
V_{PEAK}	Peak Supply Voltage ($t = 50\text{ms}$)	40	V
I_O	Audio Channels Output Peak Current (not rep. $t = 100\mu\text{s}$)	4	A
I_O	Audio Channels Output Peak Current (rep. $f > 10\text{Hz}$)	3	A
I_O	Switch Output Peak Current	(internally limited) 1.5	A
P_{tot}	Power Dissipation ($T_{case} = 85^\circ\text{C}$)	32	W
T_{stg}, T_j	Storage and Junction Temperature	-40 to 150	$^\circ\text{C}$

THERMAL DATA

Symbol	Description	Value	Unit
$R_{th\ j-case}$	Thermal Resistance Junction-case	Max 2	$^\circ\text{C/W}$

ELECTRICAL CHARACTERISTICS (Refer to the test circuit; $V_S = 14.4V$; $R_L = 4\Omega$, $T_{amb} = 25^\circ C$, $f = 1kHz$, unless otherwise specified)

Symbol	Parameter	Test Condition	Min.	Typ.	Max.	Unit
V_S	Supply Range		8		18	V
I_d	Total Quiescent Drain Current	Power Switch Unloaded		80		mA
P_O	Output Power	$R_L = 4\Omega$; THD = 10% each channel	5.5	6		W
		$R_L = 2\Omega$; THD = 10% each channel		9		W
d	Distortion	$P_O = 0.1$ to $3W$		0.08	0.3	%
CT	Cross Talk	$f = 1kHz$; $R_g = 0$	50	55		dB
		$f = 10kHz$; $R_g = 0$		50		dB
R_{IN}	Input Impedance		40	50		$K\Omega$
G_V	Voltage Gain		39	40	41	dB
G_V	Voltage Gain Match.				1	dB
E_{IN}	Input Noise Voltage (*)	$R_g = 0$		1.2	5	μV
SVR	Supply Voltage Rejection	$R_g = 0$; $f = 100Hz$; $V_r = 0.5V_{rms}$	45	50		dB
ASB	Stand-by Attenuation		60	90		dB
I_{SB}	ST-BY Current Consumption				100	μA
$V_{SB IN}$	ST-BY IN Threshold Voltage				1.5	V
$V_{SB OUT}$	ST-BY OUT Threshold Voltage		3.5			V
$V_{M IN}$	MUTE IN Threshold Voltage				1.5	V
$V_{M OUT}$	MUTE OUT Threshold Voltage		3.5			V

POWER SWITCH CHARACTERISTICS

Symbol	Parameter	Test Condition	Min.	Typ.	Max.	Unit
I_{OP}	Continuous Output Current			1.2		A
V_{DROP}	Dropout Voltage	$I_o = 1A$			1.4	V

(*) 22Hz to 22KHz
(**) A weighted

TEST AND APPLICATION CIRCUIT

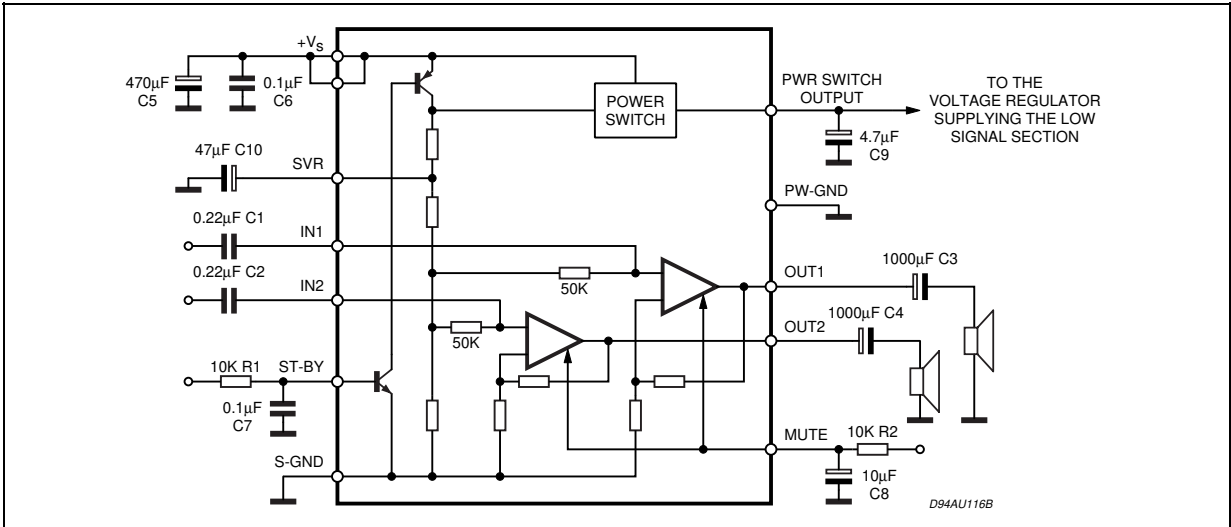

Figure 1: P.C.Board and component layout of the Test and Application Circuit 1:1 scale.

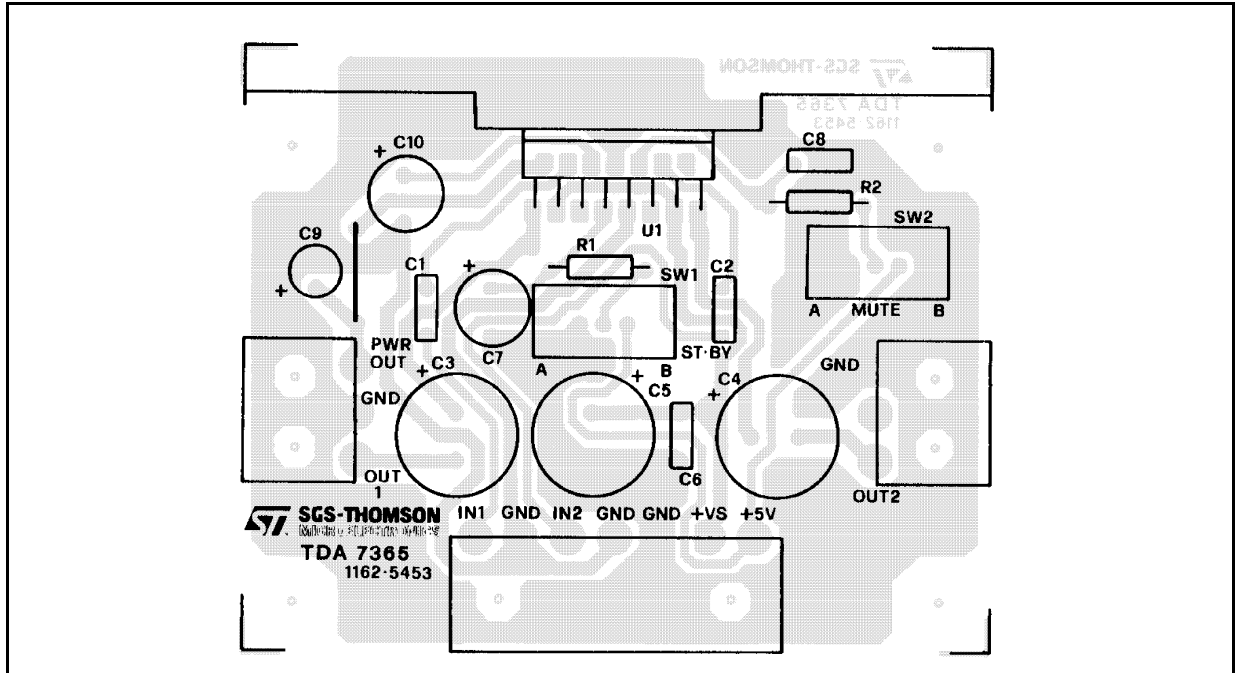

Figure 2: Quiescent Drain Current vs. Supply Voltage

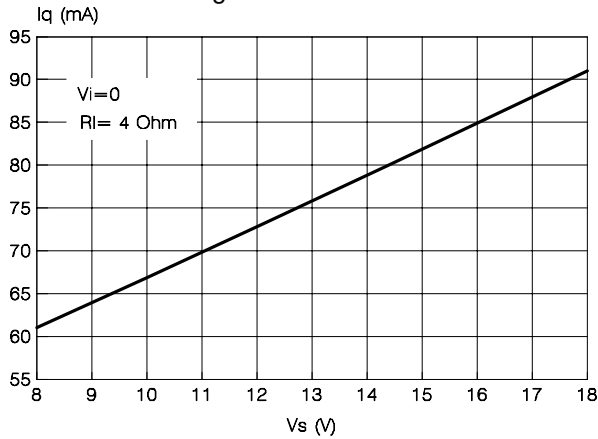

Figure 4: Output Power vs. Supply Voltage

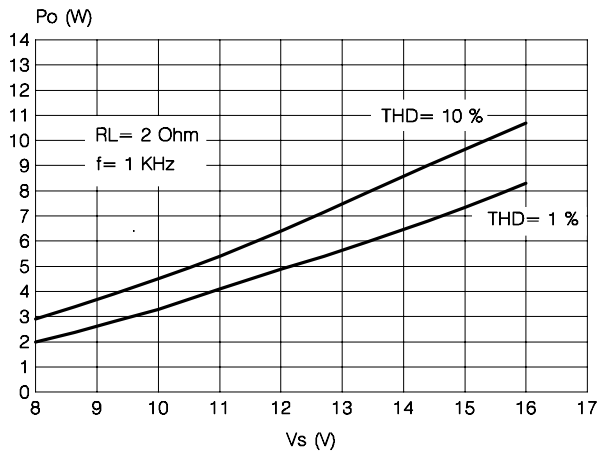

Figure 3: Output Power vs. Supply Voltage

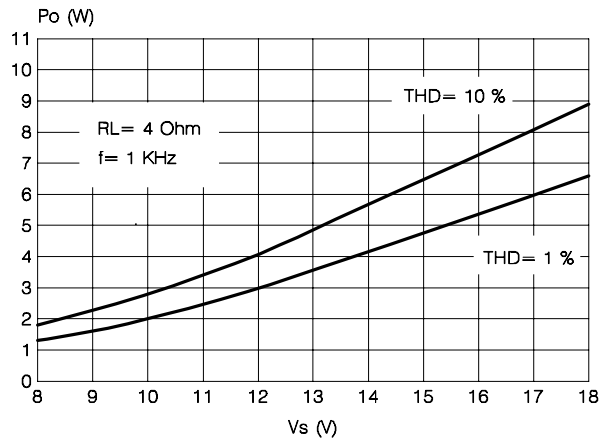

Figure 5: Distortion vs. Output Power

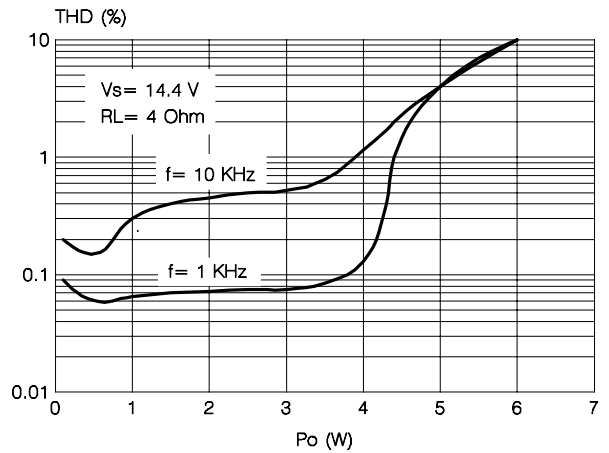

Figure 6: Distortion vs. Frequency

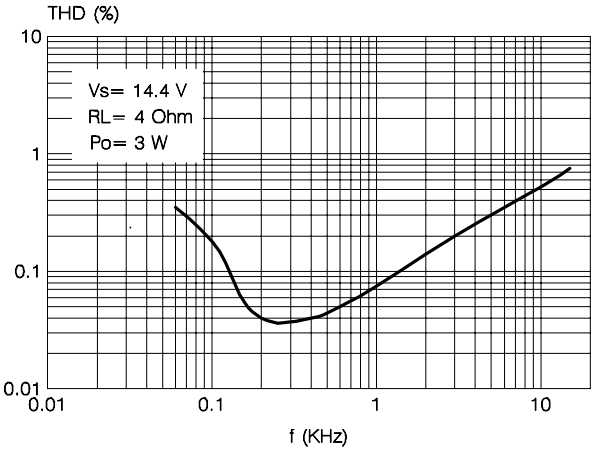

Figure 7: Supply Voltage Rejection

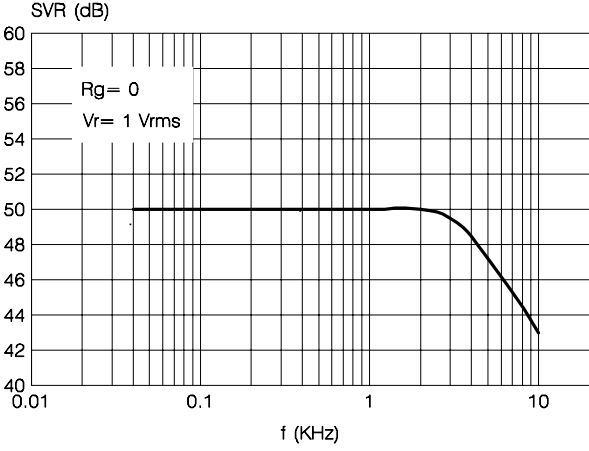

Figure 8: Cross-Talk vs. Frequency

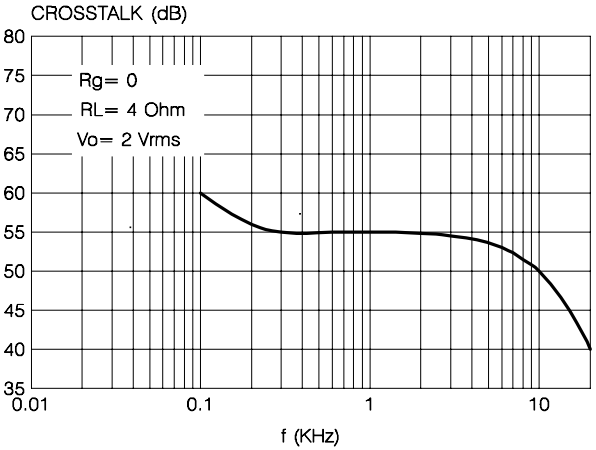

Figure 9: Switch Drop-out vs. Switch Current

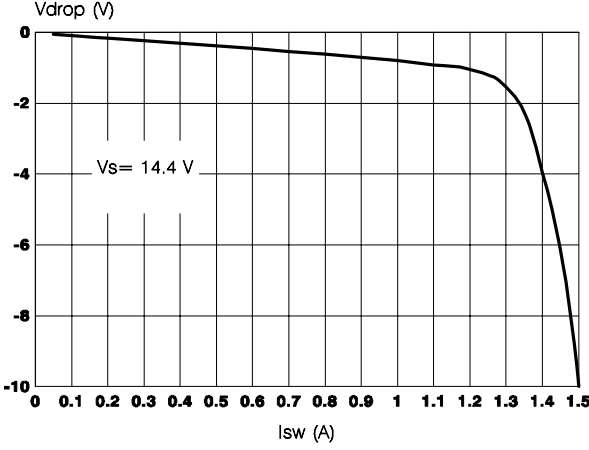

Figure 10: Total Power Dissipation and Efficiency vs. Output Power

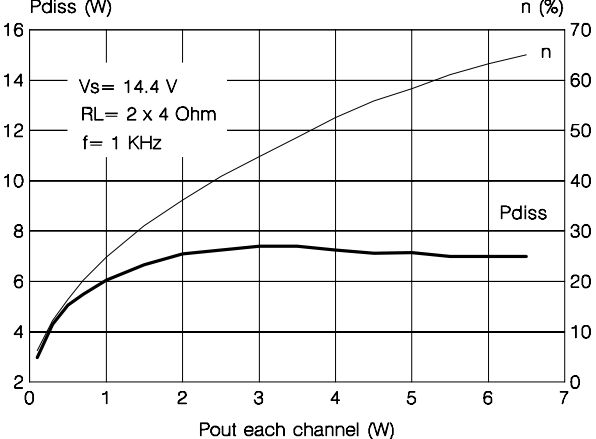
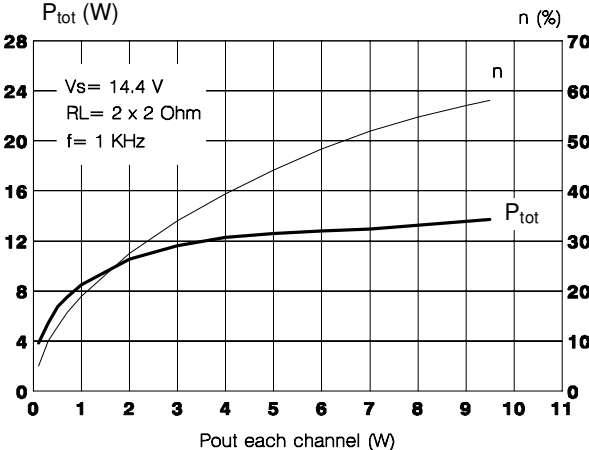
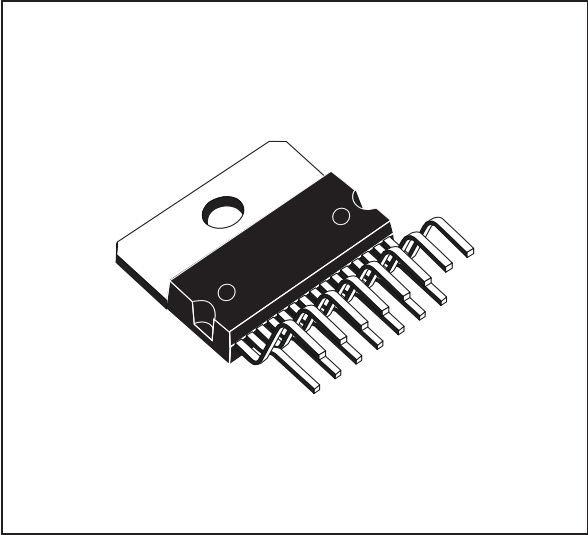

Figure 11: Total Power Dissipation and Efficiency vs. Output Power



DIM.	mm			inch		
	MIN.	TYP.	MAX.	MIN.	TYP.	MAX.
A			5			0.197
B			2.65			0.104
C			1.6			0.063
D		1			0.039	
E	0.49		0.55	0.019		0.022
F	0.66		0.75	0.026		0.030
G	1.02	1.27	1.52	0.040	0.050	0.060
G1	17.53	17.78	18.03	0.690	0.700	0.710
H1	19.6			0.772		
H2			20.2			0.795
L	21.9	22.2	22.5	0.862	0.874	0.886
L1	21.7	22.1	22.5	0.854	0.870	0.886
L2	17.65		18.1	0.695		0.713
L3	17.25	17.5	17.75	0.679	0.689	0.699
L4	10.3	10.7	10.9	0.406	0.421	0.429
L7	2.65		2.9	0.104		0.114
M	4.25	4.55	4.85	0.167	0.179	0.191
M1	4.63	5.08	5.53	0.182	0.200	0.218
S	1.9		2.6	0.075		0.102
S1	1.9		2.6	0.075		0.102
Dia1	3.65		3.85	0.144		0.152

OUTLINE AND MECHANICAL DATA



Multiwatt15 V

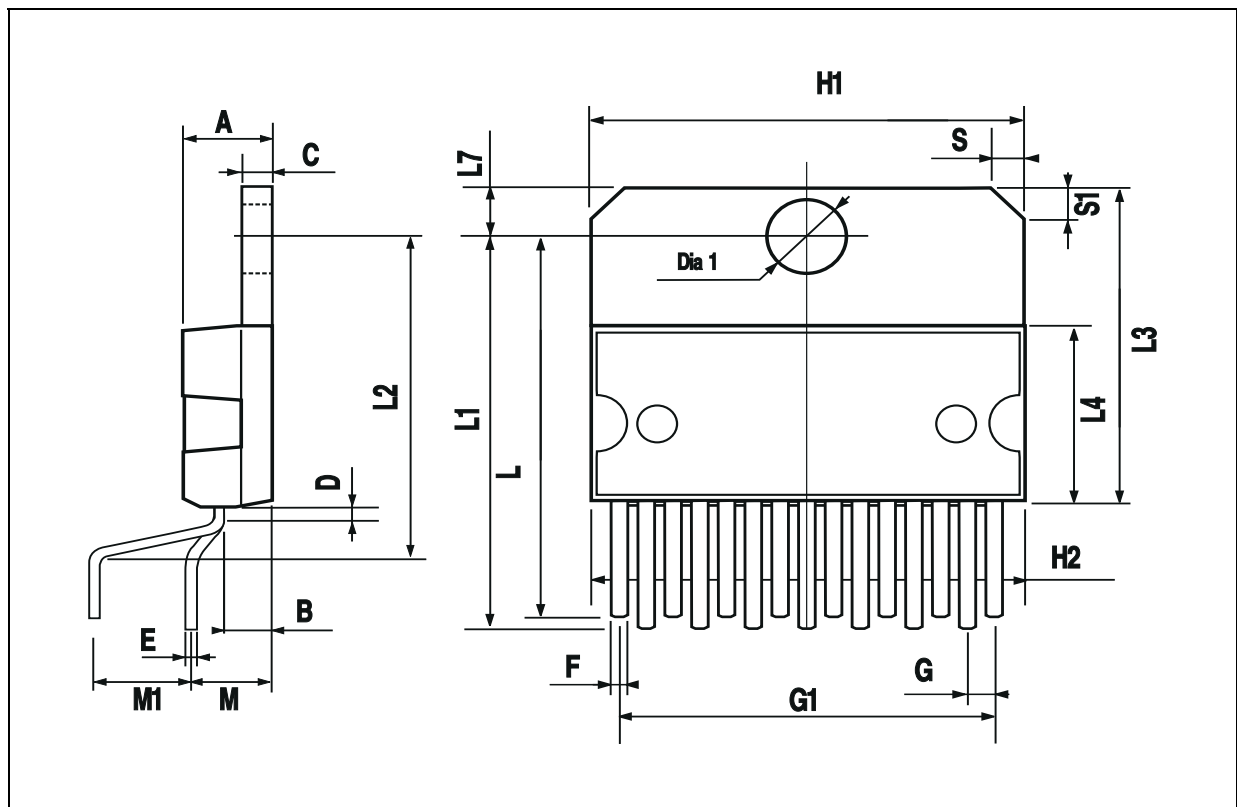

Information furnished is believed to be accurate and reliable. However, STMicroelectronics assumes no responsibility for the consequences of use of such information nor for any infringement of patents or other rights of third parties which may result from its use. No license is granted by implication or otherwise under any patent or patent rights of STMicroelectronics. Specifications mentioned in this publication are subject to change without notice. This publication supersedes and replaces all information previously supplied. STMicroelectronics products are not authorized for use as critical components in life support devices or systems without express written approval of STMicroelectronics.

The ST logo is a registered trademark of STMicroelectronics.
All other names are the property of their respective owners

© 2003 STMicroelectronics - All rights reserved

STMicroelectronics GROUP OF COMPANIES

Australia – Belgium - Brazil - Canada - China – Czech Republic - Finland - France - Germany - Hong Kong - India - Israel - Italy - Japan - Malaysia - Malta - Morocco - Singapore - Spain - Sweden - Switzerland - United Kingdom - United States

www.st.com

