



Chipsmall Limited consists of a professional team with an average of over 10 year of expertise in the distribution of electronic components. Based in Hongkong, we have already established firm and mutual-benefit business relationships with customers from,Europe,America and south Asia,supplying obsolete and hard-to-find components to meet their specific needs.

With the principle of “Quality Parts,Customers Priority,Honest Operation,and Considerate Service”,our business mainly focus on the distribution of electronic components. Line cards we deal with include Microchip,ALPS,ROHM,Xilinx,Pulse,ON,Everlight and Freescale. Main products comprise IC,Modules,Potentiometer,IC Socket,Relay,Connector.Our parts cover such applications as commercial,industrial, and automotives areas.

We are looking forward to setting up business relationship with you and hope to provide you with the best service and solution. Let us make a better world for our industry!



Contact us

Tel: +86-755-8981 8866 Fax: +86-755-8427 6832

Email & Skype: info@chipsmall.com Web: www.chipsmall.com

Address: A1208, Overseas Decoration Building, #122 Zhenhua RD., Futian, Shenzhen, China





TDA7396

45W/2Ω BRIDGE CAR RADIO AMPLIFIER WITH DIAGNOSTIC FACILITY

- HIGH POWER CAPABILITY:
 - 65W/2Ω MAX
 - 60W/2Ω EIAJ
 - 45W/2Ω @ $V_s = 14.4V$, $f = 1KHz$, $d = 10\%$
- DIFFERENTIAL INPUTS (EITHER SINGLE ENDED OR DIFFERENTIAL INPUT SIGNALS ARE ACCEPTED)
- MINIMUM EXTERNAL COMPONENT COUNT:
 - NO BOOTSTRAP CAPACITORS
 - NO BOUCHEROT CELLS
 - INTERNALLY FIXED GAIN (26dB)
 - NO SVR CAPACITOR
- ST.-BY FUNCTION (CMOS COMPATIBLE)
- AUTOMATIC MUTE DURING TURN-ON/OFF
- AUTOMUTE AT MINIMUM SUPPLY VOLTAGE DETECTION
- SYNCHRONIZING PIN FOR SIMULTANEOUS TURN-ON IN MULTI-DEVICE APPLICATIONS
- NO AUDIBLE POP DURING MUTE AND ST-BY OPERATIONS

Diagnostic Facilities:

- CLIPPING DETECTOR

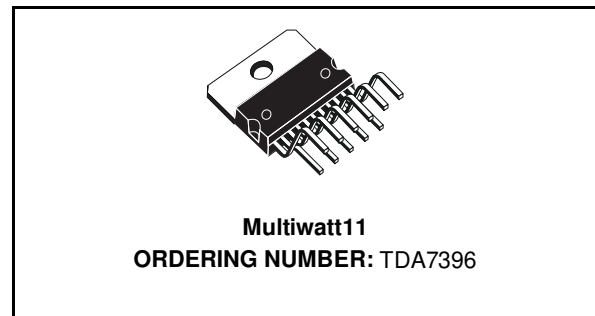

- SHORT CIRCUIT
- OPEN LOAD
- THERMAL SHUTDOWN

PROTECTIONS:

- SHORT CIRCUIT (TO GND, TO V_s , ACROSS THE LOAD)
- VERY INDUCTIVE LOADS
- CHIP OVER-TEMPERATURE
- LOAD DUMP
- OPEN GND
- ESD

Figure 1: Test And Application Circuit

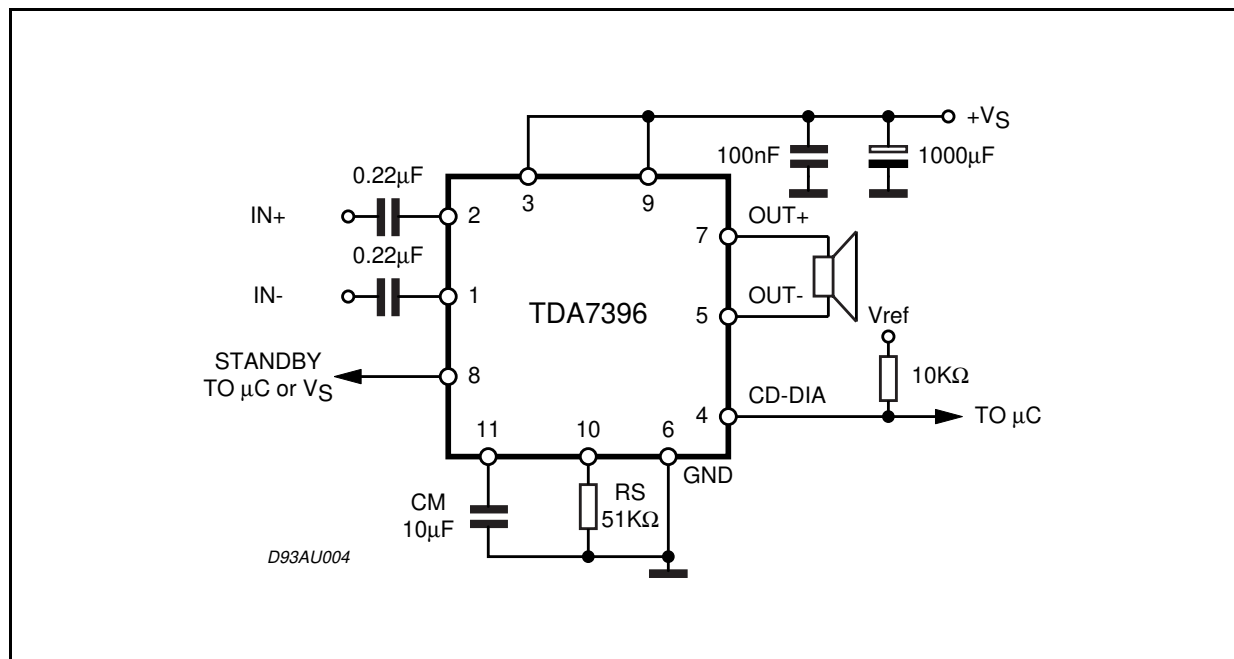

TDA7396

DESCRIPTION

The TDA7396 is a BRIDGE class AB audio power amplifier especially intended for car radio High Power applications. The 2Ω power capability together with the possibility to operate either in DIFFERENTIAL INPUT MODE or SINGLE ENDED INPUT MODE makes it suitable for boosters and high end car radio ap-

plications. The exclusive fully complementary output stage and the internally fixed gain configuration drop the external component count. The on board clipping detector allows easy implementation of gain compression systems. The diagnostics facility allows to detect any mistakes during car radio set assembly and wiring in the car.

Figure 2: Block Diagram

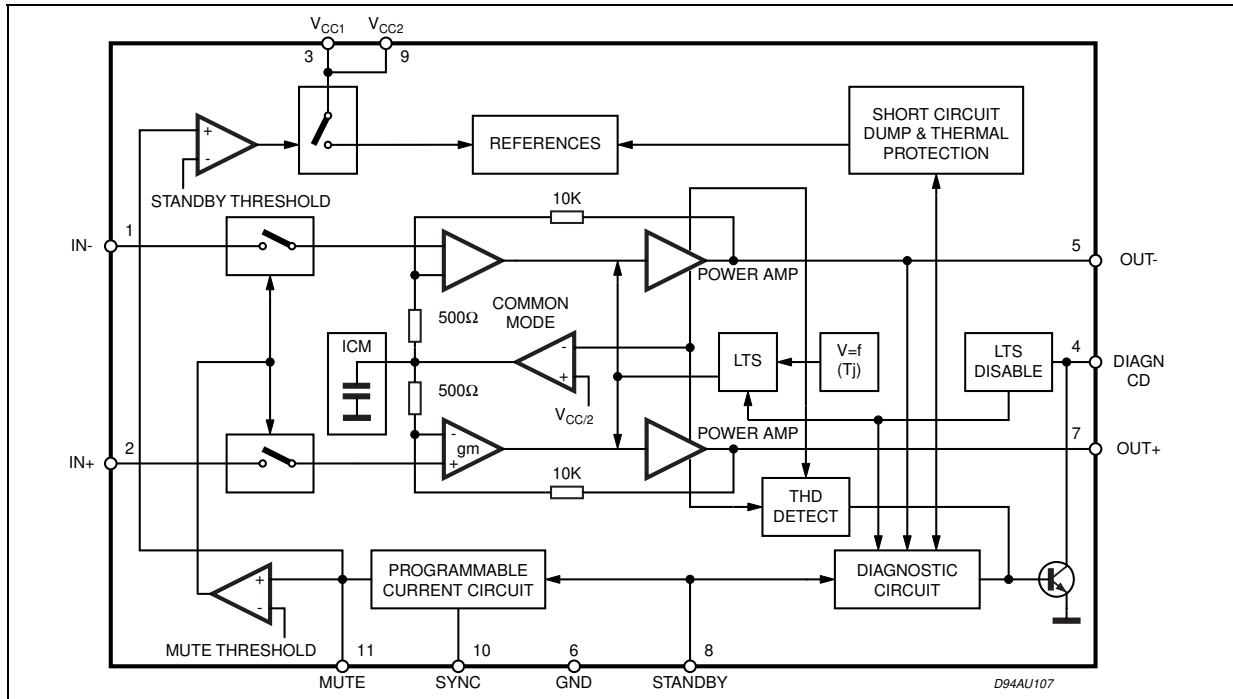

PIN CONNECTION (Top view)

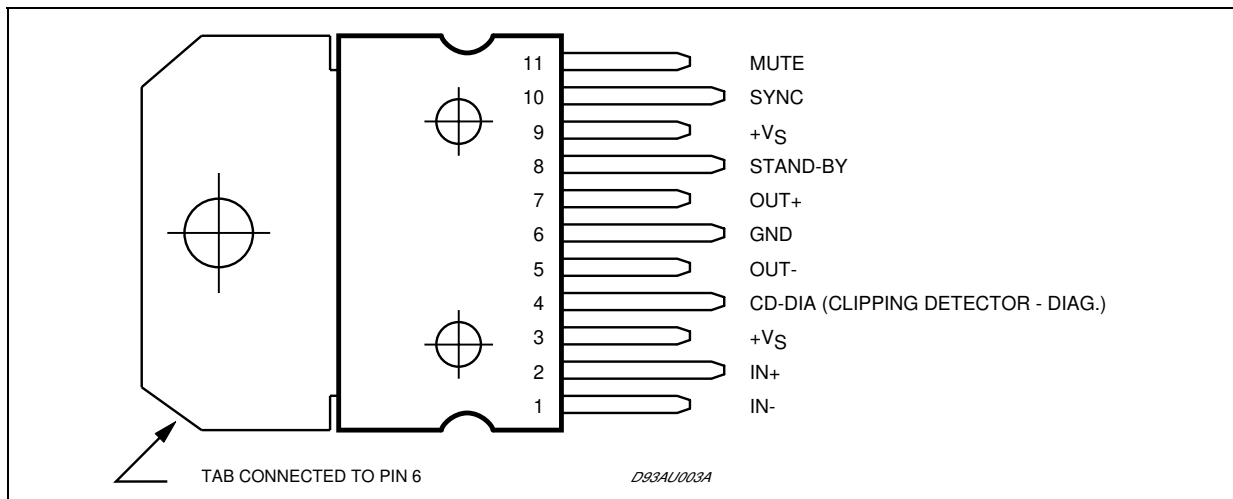

THERMAL DATA

Symbol	Description	Value	Unit
$R_{th\ j-case}$	Thermal Resistance Junction-case	Max 1.5	°C/W

ABSOLUTE MAXIMUM RATINGS

Symbol	Parameter	Value	Unit
V _S	DC Supply Voltage	28	V
V _{OP}	Operating Supply Voltage	18	V
V _{PEAK}	Peak Supply Voltage (t = 50ms)	50	V
I _O	Output Peak Current repetitive (f > 10Hz)	6	A
	Output Peak Current non repetitive	7	A
P _{tot}	Power Dissipation (T _{CASE} = 85°C)	43	W
T _{stg} , T _j	Storage and Junction-Case	-40 to 150	°C

ELECTRICAL CHARACTERISTICS (V_S = 14.4V; R_L = 2Ω, f = 1KHz, T_{amb} = 25°C, unless otherwise specified)

Symbol	Parameter	Test Condition	Min.	Typ.	Max.	Unit
V _S	Supply Voltage Range		8		18	V
I _q	Total Quiescent Current			100		mA
V _{OS}	Output Offset Voltage				150	mV
I _{SB}	ST-BY Current	V _{ST-BY} = 1.5V			100	μA
I _{SBin}	ST-BY Input Bias Current	V _{ST-BY} = 5V			10	μA
V _{SBon}	ST-BY On Threshold Voltage				1.5	V
V _{SBoff}	ST-BY Off threshold Voltage		3.5			V
ATT _{ST-BY}	ST-BY Attenuation			90		dB
R _{EXT} /R _S	Mute Resistor Ratio for External Mute Control	(see Application Circuit of fig. 4)	0.63		0.69	V
I _{M in}	Mute Input Bias Current	V _{MUTE} = 5V			10	μA
A _M	Mute Attenuation			90		dB
P _O	RMS Output Power	d = 10% d = 1% d = 10%; R _L = 4Ω		45 35 27		W W W
	EIAJ Output Power	V _S = 13.7V		60		W
d	Distortion	P _O = 0.1 to 20W P _O = 0.1 to 15W; R _L = 4Ω		0.06 0.03		% %
G _V	Voltage Gain		25	26	27	dB
f _H	High Frequency rolloff	P _O = 1W; -3dB	75			KHz
R _{IN}	Input Impedance	Differential		60		KΩ
		Single Ended		55		KΩ
E _{IN}	Input Noise Voltage	R _g = 0Ω ; f = 22Hz to 22KHz		4		μV
CMRR	Input Common Mode Rejection	f = 1KHz; V _{IN} = 1Vrms		70		dB
SVR	Supply Voltage Rejection	R _g = 0Ω; V _r = 1Vrms		60		dB
CDL	Clipping Detection Level			0.5		%
T _{sd}	Absolute Thermal Shutdown Junction Temperature			160		dB

FUNCTIONAL DESCRIPTION

Pin	Function	Description
1, 2	INPUTS	The input stage is a high impedance differential type also capable of operation in single ended mode with one input capacitively coupled to the signal GND. the impedance seen by the inverting and non inverting input pins must be matched.
4	CD - DIA	The TDA7396 is equipped with a diagnostics circuitry able to detect the following events: - Clipping in the Output Signal - Thermal Shutdown - Open Load (before turn-on) - Shorted Output: to GND, to Vs, across the load (after turn-on) The CD-DIA(open collector) pin gives out the diagnostics signal (low during clipping or output fault condition). The device does not work as long as the faulty condition holds; the normal operation is automatically restored after the fault removal.
5, 7	OUTPUTS	The output stage is a bridge type able to drive loads as high as 2Ω. It consists of two class AB fully complementary PNP/NPN stages fully protected. A rail to rail output voltage swing is achieved with no need of bootstrap capacitors. No external compensation is necessary.
8	STAND-BY	The device features a ST-BY function which shuts down all the internal bias supplies when the ST-BY input is low. In ST-BY mode the amplifier sinks a small current (in the range of few μA). When the ST-BY pin is high the IC becomes fully operational.
10	SYNC	A resistor (R _S) has to be connect between pin 10 and GND in order to program the current that flows into C _M capacitor (pin 11). The values of C _M and R _S determine the time required to bias the amplifier.
11	MUTE	a) The pin will have a capacitor (C _M) tied to GND to set the MUTE/STAND-BY time. An automatic Mute during turn on/off is provided to prevent noisy transients b) If a independent Mute function is needed, an external transistor circuit (see fig. 4) may be connected to this pin; 1% precision resistors have to be used for R _{EXT} / R _S in to order to reach the fixed limits $0.63 \leq R_{EXT} / R_S \leq 0.69$

Figure 3: Application Circuit with External Mute Control

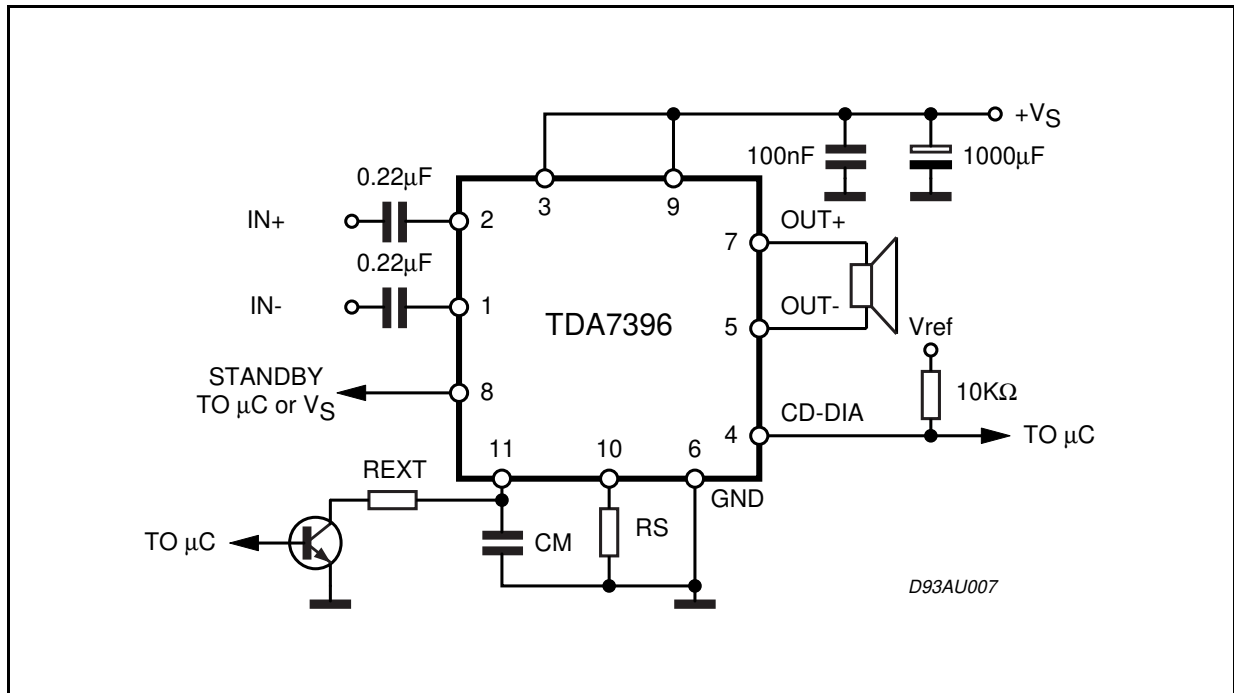

Figure 4: Quiescent Current vs Supply Voltage

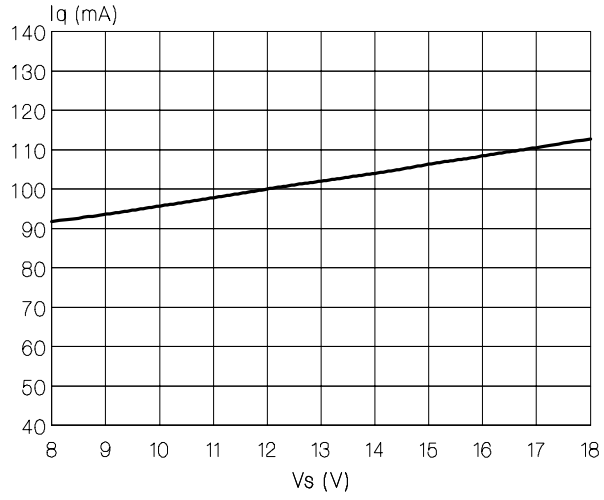

Figure 5: EIAJ power vs Supply Voltage

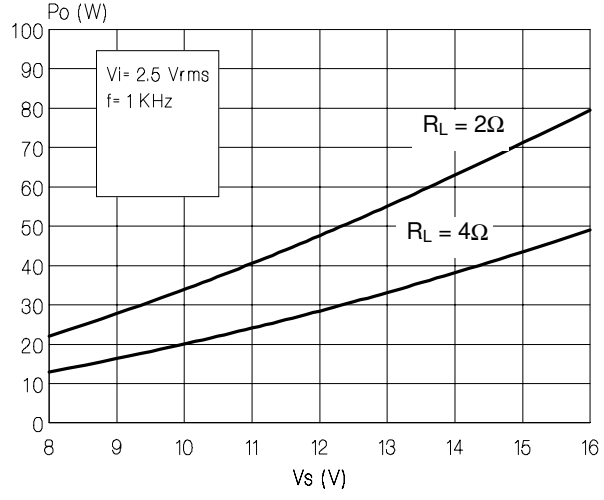

Figure 6: Output Power vs Supply Voltage (RL = 2Ω)

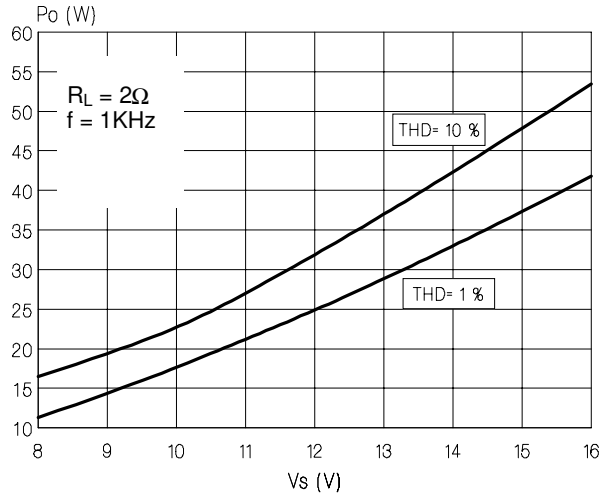

Figure 7: Distortion vs Frequency (RL = 2Ω)

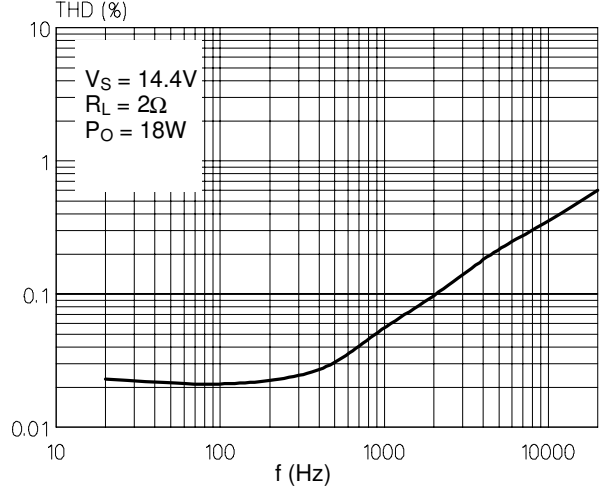

Figure 8: Output Power vs Supply Voltage (RL = 4Ω)

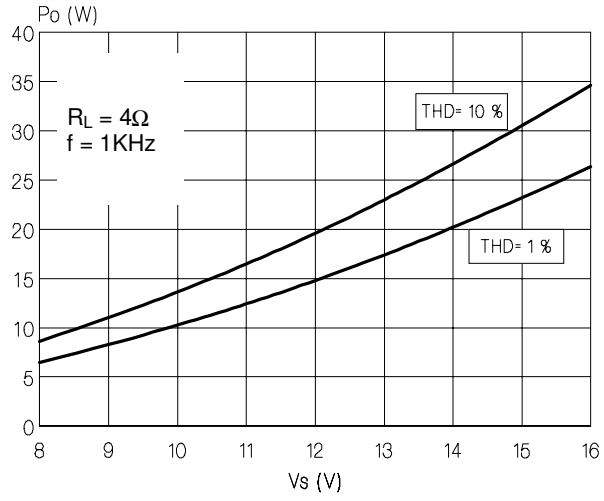

Figure 9: Distortion vs Frequency (RL = 4Ω)

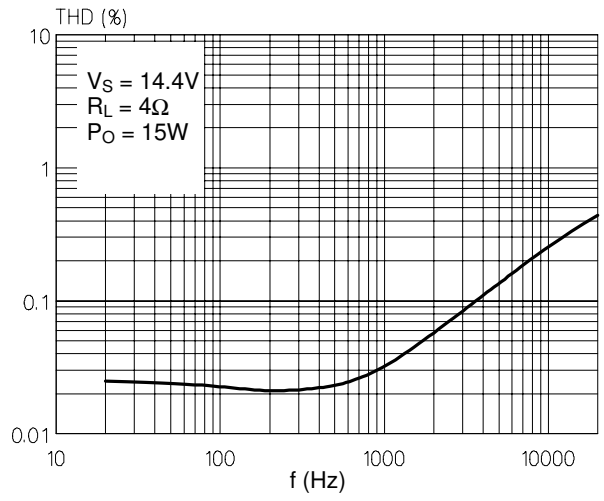

Figure 10: Supply Voltage Rejection vs Frequency

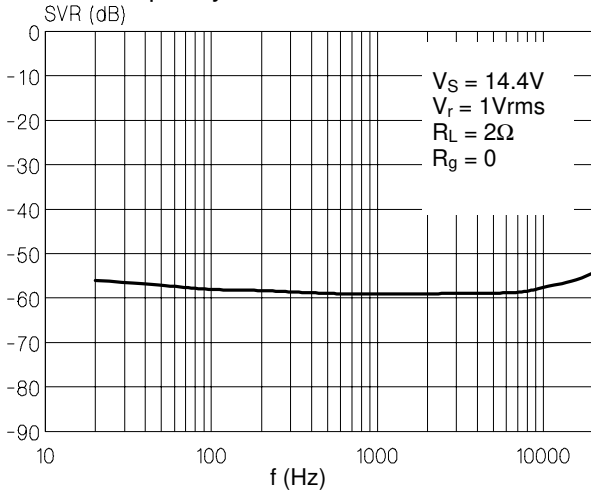

Figure 11: Common Mode Rejection vs. Frequency

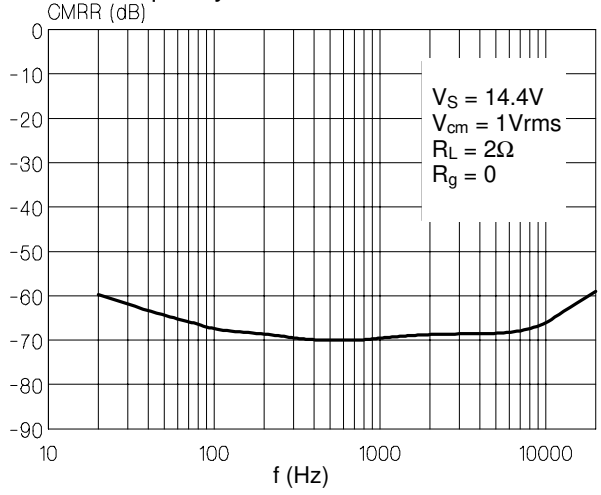

Figure 12: Total Power Dissipation & Efficiency vs. Output Power ($R_L = 2\Omega$)

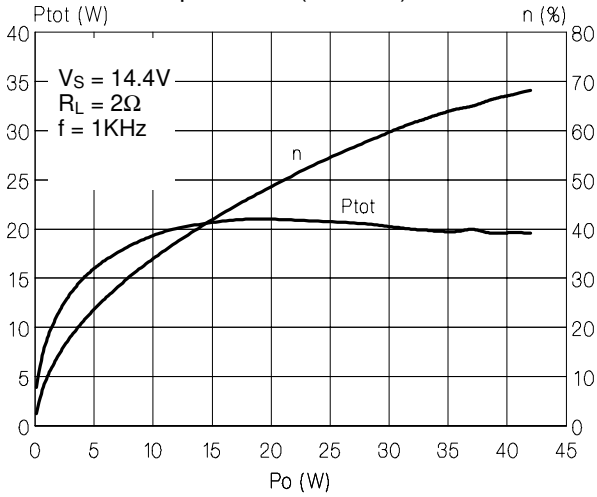

Figure 13: Total Power Dissipation & Efficiency vs. Output Power ($R_L = 4\Omega$)

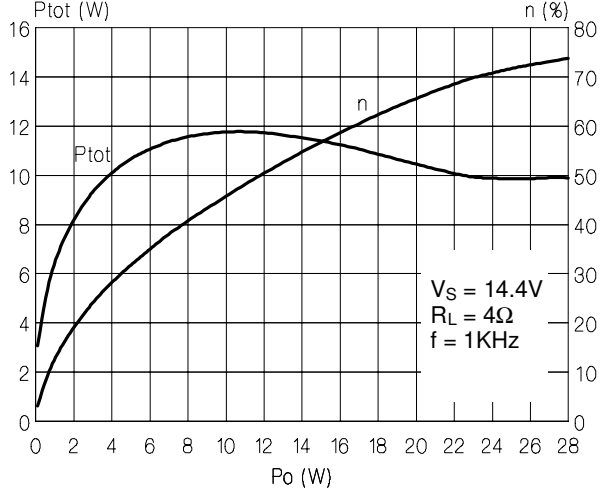

Figure 14: Application Circuit

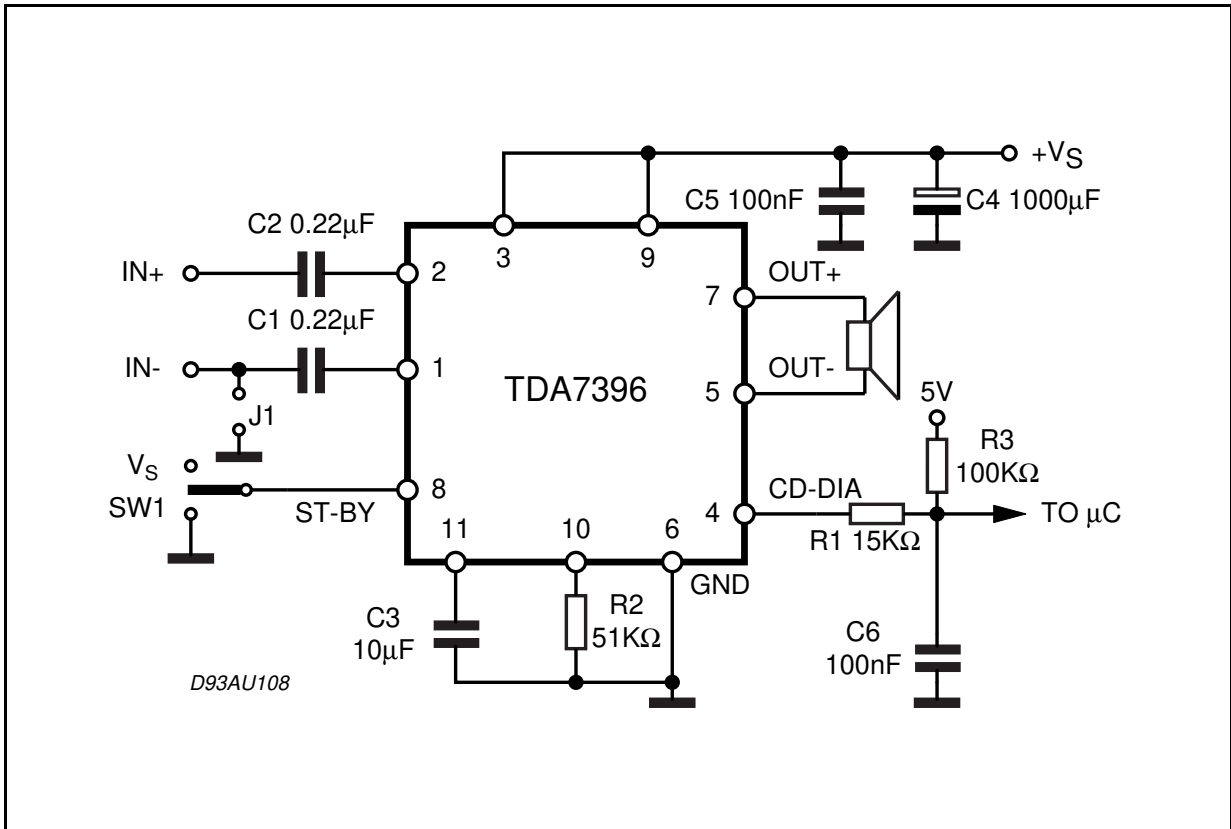
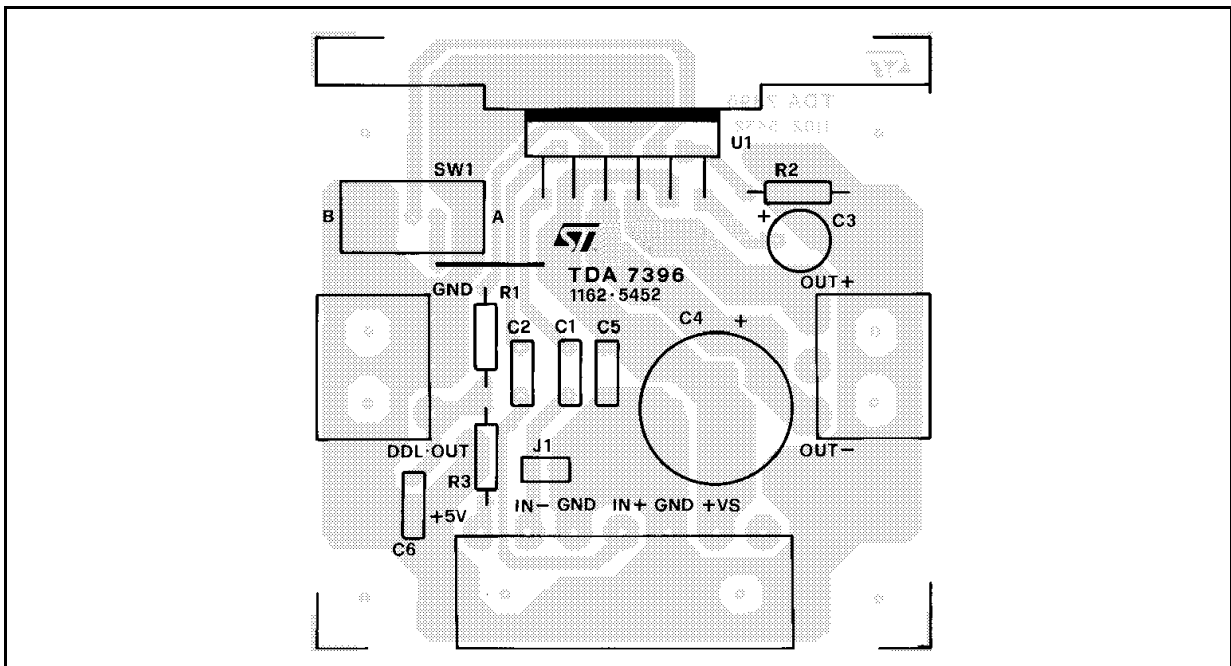

Figure 15: P.C. Board and Component Layout (1:1 scale)



CLIPPING DETECTION & DIAGNOSTICS

(see fig. 16)

An active pull-down circuit is provided to signal out the occurrence of any of the conditions described later. In order to use this function, the CD-DIA pin (#4) has to be resistively connected to a positive voltage reference (between 5V and Vs).

A) Clipping Detection

Current is sunk whenever the output clipping distortion level reaches a fixed 0.5% threshold; this function allows gain compression facility when the amplifier is overdriven.

B) Output Fault Diagnostics

Current is sunk as soon as one of the following output faults is recognized:

- short-circuit to GND
- short-circuit to Vs
- short-circuit across the load (after turn-on)
- open load (before turn-on)

The diagnostics signal remains steadily on until the fault is removed.

All the output fault conditions (listed above) can be distinguished from the clipping detection (A) because of their different time duration.

THERMAL WARNING (see fig. 17)

Thermal protection has been implemented in accordance to a new principle involving different steps:

- 1) Thermal foldback (**Linear Thermal Shutdown**)
- 2) Shutdown with soft restart (**Absolute Thermal Shutdown**)

As long as the junction temperature remains below the preset threshold (140°C) the IC delivers the full power. Once the threshold has been reached, a thermal foldback starts limiting the output signal level; the output power is then reduced, thus decreasing also the temperature without output signal interruption (LTS). Supposing the thermal foldback does not reduce the junction temperature to a safe level, a complete shutdown will occur at 160°C (ATS).

Soft restart avoids large voltage disturbance across the loudspeaker, due to the presence of high input signals when the IC comes out of thermal shutdown.

Current is sunk from the CD-DIA pin (#4) when the thermal protection is acting. The voltage at pin #4 bounces back and forth (depending on the amplifier input signal magnitude) during the linear thermal intervention (LTS) and stays low (sinking current) after the amplifier has been eventually shut-down (Absolute Thermal Shutdown)

Figure 16: Clipping Detection & Diagnostics Waveforms

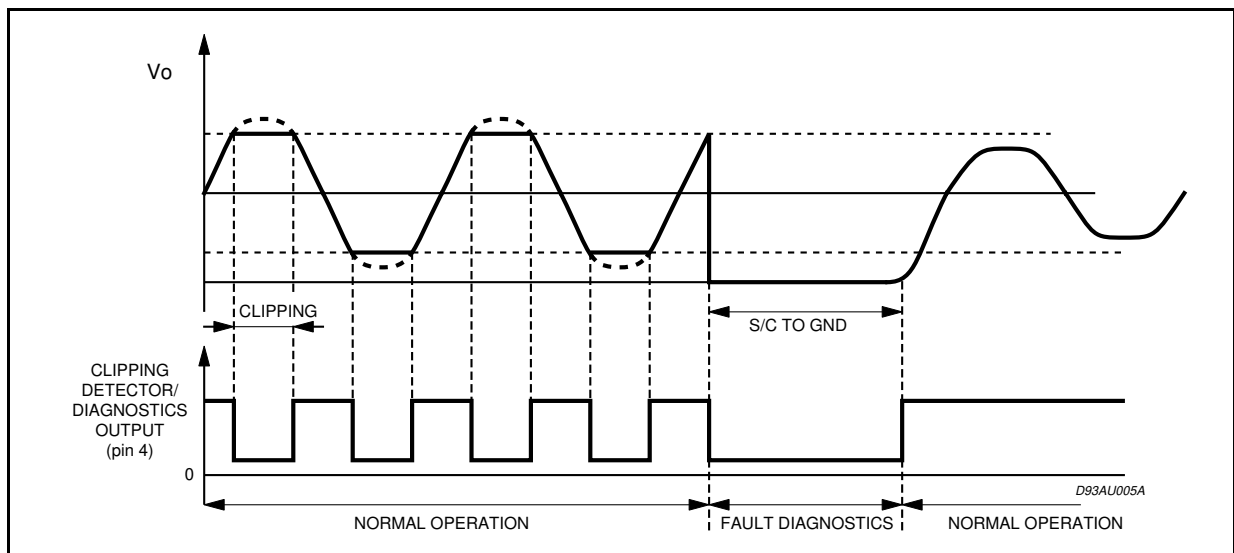
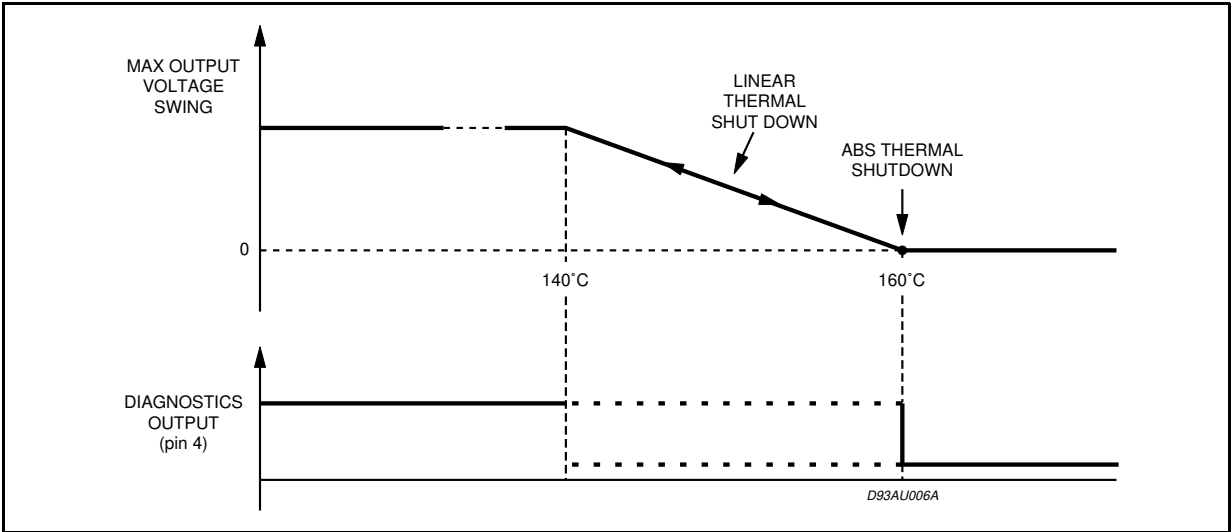
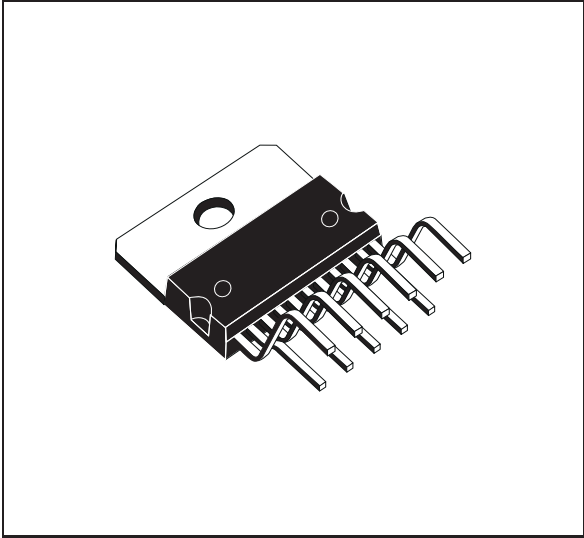

Figure 17: Thermal Protection & Diagnostic Waveforms



DIM.	mm			inch		
	MIN.	TYP.	MAX.	MIN.	TYP.	MAX.
A			5			0.197
B			2.65			0.104
C			1.6			0.063
D		1			0.039	
E	0.49		0.55	0.019		0.022
F	0.88		0.95	0.035		0.037
G	1.45	1.7	1.95	0.057	0.067	0.077
G1	16.75	17	17.25	0.659	0.669	0.679
H1	19.6			0.772		
H2			20.2			0.795
L	21.9	22.2	22.5	0.862	0.874	0.886
L1	21.7	22.1	22.5	0.854	0.87	0.886
L2	17.4		18.1	0.685		0.713
L3	17.25	17.5	17.75	0.679	0.689	0.699
L4	10.3	10.7	10.9	0.406	0.421	0.429
L7	2.65		2.9	0.104		0.114
M	4.25	4.55	4.85	0.167	0.179	0.191
M1	4.73	5.08	5.43	0.186	0.200	0.214
S	1.9		2.6	0.075		0.102
S1	1.9		2.6	0.075		0.102
Dia1	3.65		3.85	0.144		0.152

OUTLINE AND MECHANICAL DATA



Multiwatt11 V

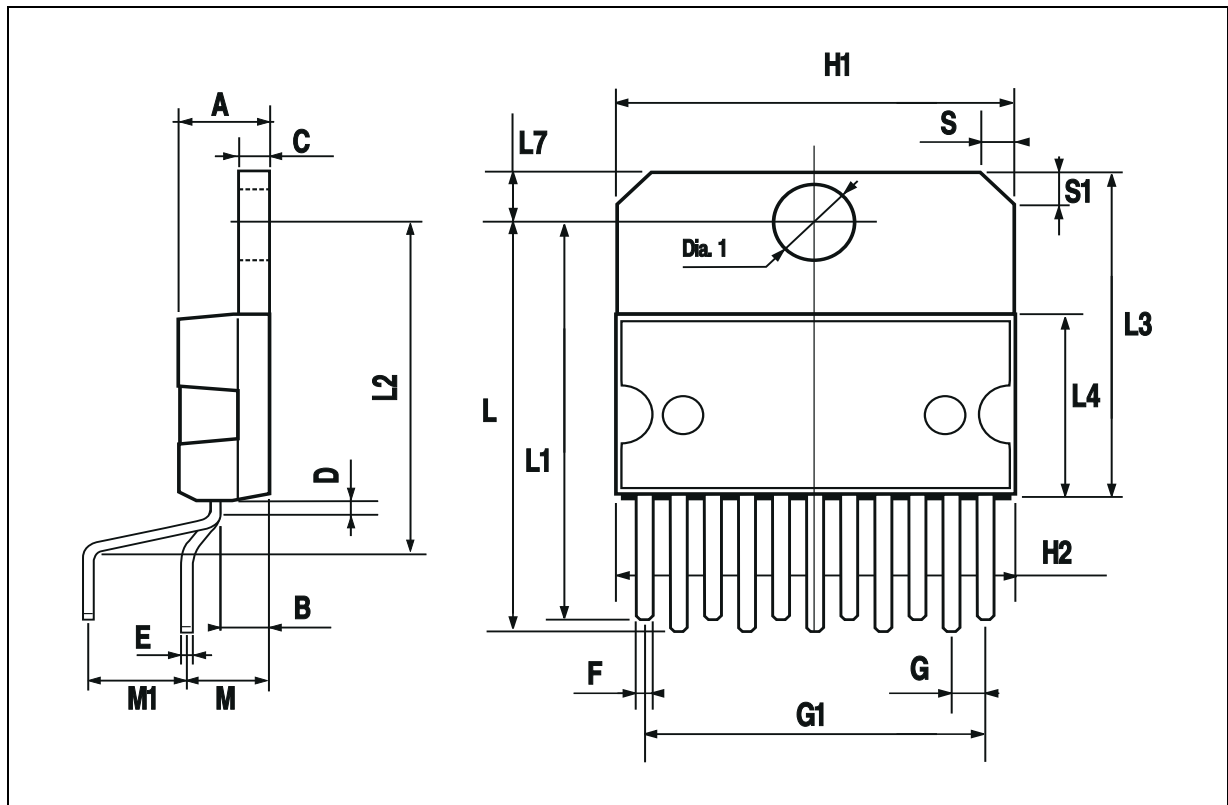

Please Read Carefully:

Information in this document is provided solely in connection with ST products. STMicroelectronics NV and its subsidiaries ("ST") reserve the right to make changes, corrections, modifications or improvements, to this document, and the products and services described herein at any time, without notice.

All ST products are sold pursuant to ST's terms and conditions of sale.

Purchasers are solely responsible for the choice, selection and use of the ST products and services described herein, and ST assumes no liability whatsoever relating to the choice, selection or use of the ST products and services described herein.

No license, express or implied, by estoppel or otherwise, to any intellectual property rights is granted under this document. If any part of this document refers to any third party products or services it shall not be deemed a license grant by ST for the use of such third party products or services, or any intellectual property contained therein or considered as a warranty covering the use in any manner whatsoever of such third party products or services or any intellectual property contained therein.

UNLESS OTHERWISE SET FORTH IN ST'S TERMS AND CONDITIONS OF SALE ST DISCLAIMS ANY EXPRESS OR IMPLIED WARRANTY WITH RESPECT TO THE USE AND/OR SALE OF ST PRODUCTS INCLUDING WITHOUT LIMITATION IMPLIED WARRANTIES OF MERCHANTABILITY, FITNESS FOR A PARTICULAR PURPOSE (AND THEIR EQUIVALENTS UNDER THE LAWS OF ANY JURISDICTION), OR INFRINGEMENT OF ANY PATENT, COPYRIGHT OR OTHER INTELLECTUAL PROPERTY RIGHT.

ST PRODUCTS ARE NOT DESIGNED OR AUTHORIZED FOR USE IN: (A) SAFETY CRITICAL APPLICATIONS SUCH AS LIFE SUPPORTING, ACTIVE IMPLANTED DEVICES OR SYSTEMS WITH PRODUCT FUNCTIONAL SAFETY REQUIREMENTS; (B) AERONAUTIC APPLICATIONS; (C) AUTOMOTIVE APPLICATIONS OR ENVIRONMENTS, AND/OR (D) AEROSPACE APPLICATIONS OR ENVIRONMENTS. WHERE ST PRODUCTS ARE NOT DESIGNED FOR SUCH USE, THE PURCHASER SHALL USE PRODUCTS AT PURCHASER'S SOLE RISK, EVEN IF ST HAS BEEN INFORMED IN WRITING OF SUCH USAGE, UNLESS A PRODUCT IS EXPRESSLY DESIGNATED BY ST AS BEING INTENDED FOR "AUTOMOTIVE, AUTOMOTIVE SAFETY OR MEDICAL" INDUSTRY DOMAINS ACCORDING TO ST PRODUCT DESIGN SPECIFICATIONS. PRODUCTS FORMALLY ESCC, QML OR JAN QUALIFIED ARE DEEMED SUITABLE FOR USE IN AEROSPACE BY THE CORRESPONDING GOVERNMENTAL AGENCY.

Resale of ST products with provisions different from the statements and/or technical features set forth in this document shall immediately void any warranty granted by ST for the ST product or service described herein and shall not create or extend in any manner whatsoever, any liability of ST.

ST and the ST logo are trademarks or registered trademarks of ST in various countries.

Information in this document supersedes and replaces all information previously supplied.

The ST logo is a registered trademark of STMicroelectronics. All other names are the property of their respective owners.

© 2013 STMicroelectronics - All rights reserved

STMicroelectronics group of companies

Australia - Belgium - Brazil - Canada - China - Czech Republic - Finland - France - Germany - Hong Kong - India - Israel - Italy - Japan - Malaysia - Malta - Morocco - Philippines - Singapore - Spain - Sweden - Switzerland - United Kingdom - United States of America

www.st.com

