



Chipsmall Limited consists of a professional team with an average of over 10 year of expertise in the distribution of electronic components. Based in Hongkong, we have already established firm and mutual-benefit business relationships with customers from,Europe,America and south Asia,supplying obsolete and hard-to-find components to meet their specific needs.

With the principle of “Quality Parts,Customers Priority,Honest Operation,and Considerate Service”,our business mainly focus on the distribution of electronic components. Line cards we deal with include Microchip,ALPS,ROHM,Xilinx,Pulse,ON,Everlight and Freescale. Main products comprise IC,Modules,Potentiometer,IC Socket,Relay,Connector.Our parts cover such applications as commercial,industrial, and automotives areas.

We are looking forward to setting up business relationship with you and hope to provide you with the best service and solution. Let us make a better world for our industry!



Contact us

Tel: +86-755-8981 8866 Fax: +86-755-8427 6832

Email & Skype: info@chipsmall.com Web: www.chipsmall.com

Address: A1208, Overseas Decoration Building, #122 Zhenhua RD., Futian, Shenzhen, China



Car radio signal processor

Features

Audio processor

- 4 Stereo inputs
- 4 Mono inputs
- Volume control
- 7 Band equalizer filter control
- High pass filter for subwoofer application
- Direct mute and soft mute
- Internal beep generation
- 4 Independent speaker outputs
- Soft step speaker control
- Subwoofer output
- 7 Band spectrum analyzer
- Full mixing capability
- Pause detector decoder

Stereo decoder

- RDS mute
- No external adjustments
- AM/FM noiseblanker with several trigger controls

Order codes

Part number	Package	Packing
E-TDA7406	TQFP44	Tray

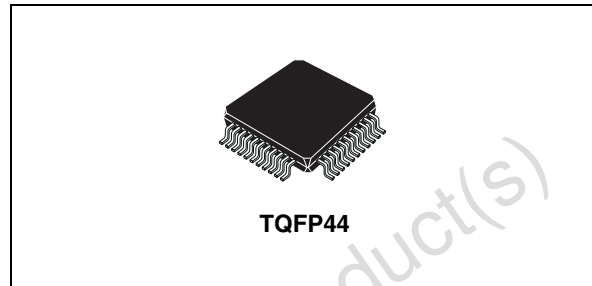

- Programmable multipath detector
- Quality detector output

Digital control

- I²C-bus interface

Description

The TDA7406 includes a high performance audio processor with 7 bands equalizer and spectrum analyzer plus a stereo decoder-noiseblanker.

The whole low frequency signal processing necessary for state-of-the-art as well as future car radios is therefore provided.

The digital control allows a full programming not only of the audioprocessor and filter characteristics but also in the stereodecoder part especially for the adaptation to different IF-devices.

Contents

- 1 Block and pin connection diagram 7**

- 2 Electrical specifications 9**
 - 2.1 Supply 9
 - 2.2 Thermal data 9
 - 2.3 Absolute maximum ratings 9
 - 2.4 ESD: 9

- 3 Audioprocessor part 10**
 - 3.1 Features: 10
 - 3.2 Audioprocessor electrical characteristics 11

- 4 Description of the audioprocessor part 16**
 - 4.1 Input stages 16
 - 4.1.1 Pseudo-differential stereo input (PD) 16
 - 4.1.2 Single-ended stereo inputs, single-ended mono inputs and FM-MPX input
16
 - 4.1.3 Mixing Selector 16
 - 4.1.4 Rec. Generator 16
 - 4.2 AutoZero 17
 - 4.2.1 AutoZero for Stereodecoder-Selection 17
 - 4.2.2 AutoZero-Remain 18
 - 4.2.3 PAUSE Detector 18
 - 4.3 Loudness 18
 - 4.4 Soft Mute 20
 - 4.5 Volume Control 20
 - 4.5.1 Gain/Attenuation Control 20
 - 4.5.2 Soft Step Volume 20
 - 4.6 The Seven Band Equalizer 21
 - 4.6.1 Equalizer Filter 21
 - 4.6.2 DC-Mode 23
 - 4.7 Subwoofer Application 23
 - 4.8 Spectrum analyzer 24

4.8.1	Spectrum Analyzer Filters	24
4.9	AC-coupling	25
4.10	Speaker-Attenuator stage	26
4.11	Output Mixer	26
4.12	Audioprocessor Testing	26
5	Stereodecoder part	27
5.1	Features:	27
5.2	Stereodecoder electrical characteristics	27
5.3	Dual MPX Usage	30
6	Noise blanker part	31
6.1	Features:	31
6.2	Noise blanker electrical characteristics	31
7	Multipath detector	34
7.1	Features:	34
7.2	Multipath detector electrical characteristics	34
8	Functional Description of Stereodecoder	35
8.1	Stereodecoder-Mute	35
8.2	InGain + InFilter	36
8.3	Demodulator	36
8.4	De-emphasis and Highcut	37
8.5	PLL and Pilot tone-Detector	37
8.6	Fieldstrength Control	37
8.7	LEVEL-Input and -Gain	37
8.8	Stereoblend Control	37
8.9	Highcut Control	38
9	Functional description of the noiseblanker	40
9.1	Trigger Path FM	40
9.2	Noise Controlled Threshold Adjustment (NCT)	40
9.3	Additional Threshold Control Mechanism	41
9.3.1	Automatic Threshold Control by the Stereoblend voltage	41

9.3.2	Over Deviation Detector	41
9.3.3	Multipath-Level	41
9.3.4	AM mode of the Noiseblanker	41
10	Functional description of the multipath-detector	42
11	Quality detector	43
12	Testmode	44
13	I2C bus interface	45
13.1	Interface Protocol	45
13.1.1	Auto increment	45
13.1.2	TRANSMITTED DATA (send mode)	45
13.1.3	Reset Condition	45
13.2	Subaddress (receive mode)	46
13.3	Data byte specification	47
14	Application diagram	61
15	Package information	62
16	Revision history	63

List of tables

Table 1.	Supply	9
Table 2.	Thermal data	9
Table 3.	Absolute maximum ratings	9
Table 4.	Audioprocessor electrical characteristics	11
Table 5.	Stereodecoder electrical characteristics	27
Table 6.	Noise blanker electrical characteristics	31
Table 7.	Multipath detector electrical characteristics	34
Table 8.	Subaddress (receive mode)	46
Table 9.	Input Selector (0)	47
Table 10.	Loudness (1)	47
Table 11.	Volume (2)	48
Table 12.	Equalizer (3,4,5,6,7,8,9)	48
Table 13.	Mixing Programming (10)	49
Table 14.	SoftMute (11)	49
Table 15.	Subwoofer Configuration / Spectrum Analyzer / HighPass (12)	50
Table 16.	Configuration Audioprocessor I (13)	50
Table 17.	Configuration Audioprocessor II (14)	51
Table 18.	Speaker and Subwoofer Level Control (15,16,17,18,19)	52
Table 19.	Mixer Level Control (20)	52
Table 20.	Testing Audioprocessor (21)	53
Table 21.	Stereodecoder (22)	53
Table 22.	Noiseblanker I (23)	54
Table 23.	Noiseblanker II (24)	55
Table 24.	AM / FM-Noiseblanker (25)	55
Table 25.	High-Cut (26)	56
Table 26.	Fieldstrength Control (27)	57
Table 27.	Multipath Detector (28)	57
Table 28.	Stereodecoder Adjustment (29)	58
Table 29.	Stereodecoder Configuration (30)	59
Table 30.	Testing Stereodecoder(31)	59
Table 31.	Document revision history	63

List of figures

Figure 1.	Block diagram	7
Figure 2.	Pin connection (Top view)	8
Figure 3.	Input-stages	17
Figure 4.	Loudness Attenuation @ $f_P = 400\text{Hz}$	19
Figure 5.	Loudness Center frequencies @ Attn. = 15dB	19
Figure 6.	1st and 2nd Order Loudness @ Attn. = 15dB, $f_P=400\text{Hz}$	19
Figure 7.	Soft Mute-Timing	20
Figure 8.	SoftStep-Timing for Volume	21
Figure 9.	Equalizer filter control @ $f_{\text{Center}} = 1\text{kHz}$, $Q = 1.0$	22
Figure 10.	Center frequencies @ Gain = 15dB, $Q = 1.0$	22
Figure 11.	Quality factors @ boost = 15dB, $f_{\text{Center}} = 1\text{kHz}$	22
Figure 12.	Superposition of all EQ bands @ boost = 15dB	23
Figure 13.	EQ band1, normal- and DC-mode @ boost = 15 dB, $f_{\text{Center}} = 62\text{ Hz}$	23
Figure 14.	Subwoofer Application with Lowpass @ 80/120/160Hz and HighPass @ 30/135/180Hz	24
Figure 15.	Spectrum analyzer block diagram	25
Figure 16.	Timing spectrum analyzer.	25
Figure 17.	AC/DC-coupling and MixIn Inputs.	26
Figure 18.	Output Selector.	26
Figure 19.	Block diagram Dual MPX	30
Figure 20.	Trigger Threshold vs. VPEAK.	33
Figure 21.	Deviation Controlled Trigger Adjustment	33
Figure 22.	Fieldstrength Controlled Trigger Adjustment	33
Figure 23.	Block diagram of the stereodecoder	35
Figure 24.	Signals during stereodecoder's SoftMute	36
Figure 25.	Signal-Control via SoftMute-Pin	36
Figure 26.	Internal stereoblend characteristics	38
Figure 27.	Relation between internal and external LEVEL-voltages for setup of Stereoblend	38
Figure 28.	Highcut characteristics	39
Figure 29.	Block diagram of the noiseblanker	40
Figure 30.	Block diagram of the Multipath-Detector.	42
Figure 31.	Application Diagram	61
Figure 32.	TQFP44 Mechanical Data & Package Dimensions	62

1 Block and pin connection diagram

Figure 1. Block diagram

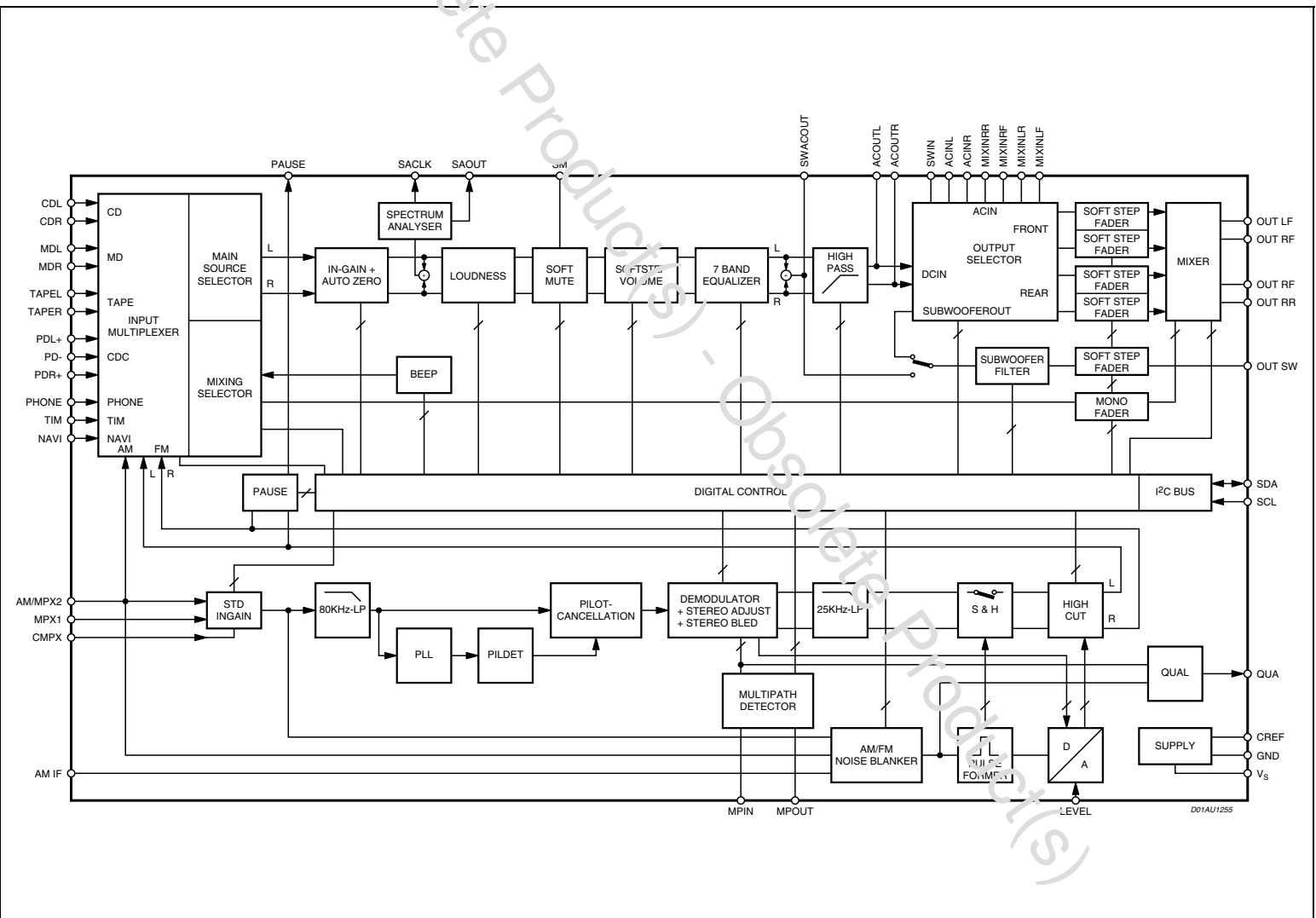
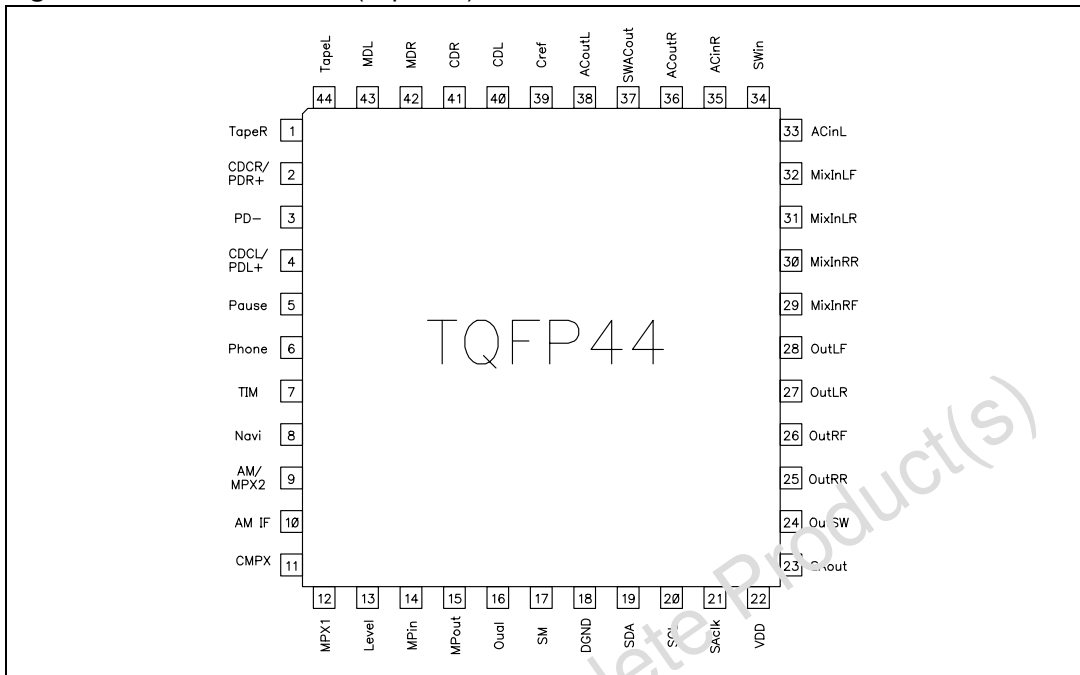

Figure 2. Pin connection (Top view)



Obsolete Product(s) - Obsolete Product(s)

2 Electrical specifications

2.1 Supply

Table 1. Supply

Symbol	Parameter	Test Conditions	Min.	Typ.	Max.	Unit
V_S	Supply Voltage		7.5	9	10	V
I_S	Supply Current	$V_S = 9V$	42	60	78	mA
SVRR	Ripple Rejection @ 1kHz	Audioprocessor (all Filters flat)		60		dB
		Stereodecoder + Audioprocessor		55		dB

2.2 Thermal data

Table 2. Thermal data

Symbol	Description	Value	Unit
$R_{th\ j-pins}$	Thermal Resistance Junction-pins	max 65	°C/W

2.3 Absolute maximum ratings

Table 3. Absolute maximum ratings

Symbol	Parameter	Value	Unit
V_S	Operating Supply Voltage	10.5	V
T_{amb}	Operating Temperature Range	-40 to 85	°C
T_{stg}	Storage Temperature Range	-55 to +150	°C

2.4 ESD:

All pins are protected against ESD according to the MIL883 standard.

3 Audioprocessor part

3.1 Features:

- Input multiplexer
 - Pseudo differential CDC stereo input, programmable as single-ended input.
 - 3 single-ended stereo inputs.
 - 4 single-ended mono inputs.
 - Input gain adjust 0...15dB in 1dB steps.
 - Internal offset-cancellation (autozero).
- Beep
 - Internal beep generator with 4 different frequencies.
- Mixing stage
 - Beep, Phone- and Navi-Input mixable to all speaker outputs.
 - TIM or tuner (FM/AM) programmable as fourth mixing source.
 - Level control range of 95dB (+15...-79db).
- Loudness
 - Loudness programmable center frequency and filter slope.
 - 0...19dB attenuation in 1dB steps.
 - selectable flat-mode (constant attenuation).
- Volume
 - Gain/Attenuation with 0.5dB step resolution.
 - soft-step control with programmable blend times.
 - 110dB range (+22...-79db).
- Equalizer
 - Seven bands equalizer with 2nd order frequency response switch-capacitors filters.
 - Center frequency programmable for lowest and highest filter.
 - Programmable quality factor in four steps for each filter.
 - ±15dB range with 1dB steps.
- Spectrum analyzer
 - seven bandpass 2nd order frequency response switch-capacitors filters
 - Programmable quality factor for different visual appearance
 - Analog output
 - Controlled by external serial clock
- High pass Filter
 - 2nd order Butterworth high pass with programmable cut-off frequency
 - Selectable flat-mode
- Speakers
 - 4 independent speaker controls with separate mute.
 - Control range 95dB (+15...-79dB) in 1dB steps with soft step.
 - 4 independent programmable mix inputs with 50% mixing ratio
- Subwoofer

- Single-ended monaural output
- control range 95dB (+15...-79dB) in 1dB steps with soft step.
- separate mute
- Mute functions
 - direct mute
 - digitally controlled Soft mute with 4 programmable mute-time

3.2 Audioprocessor electrical characteristics

Table 4. Audioprocessor electrical characteristics
($V_S=9V$; $T_{amb}=25^{\circ}C$; $R_L=10k\Omega$; all gains=0dB; $f=1kHz$; unless otherwise specified)

Symbol	Parameter	Test Condition	Min.	Typ.	Max.	Unit
INPUT SELECTOR						
R_{in}	Input Resistance	all single ended Inputs	70	100	130	$k\Omega$
V_{CL}	Clipping Level		2.2	2.6		V_{RMS}
S_{IN}	Input Separation		80	100		dB
$G_{IN MIN}$	Min. Input Gain		-1	0	1	dB
$G_{IN MAX}$	Max. Input Gain		13	15	17	dB
G_{STEP}	Step Resolution		0.5	1	1.5	dB
V_{DC}	DC Steps	Adjacent Gain Steps	-5	1	5	mV
		G_{MIN} to G_{MAX}	-10	1	10	mV
V_{offset}	Remaining offset with Autozero			0.5		mV
DIFFERENTIAL STEREO INPUTS						
R_{in}	Input Resistance (see Fig. 1)	Differential	70	100	130	$k\Omega$
CMRR	Common Mode Rejection Ratio	$V_{CM} = 1V_{RMS}$ @ 1kHz	46	70		dB
		$V_{CM} = 1V_{RMS}$ @ 10kHz	46	60		dB
e_{NC}	Output-Noise @ Speaker-Outputs	20Hz - 20kHz, flat; all stages 0dB		11		μV
BEEP CONTROL						
V_{RMS}	Beep Level	Mix-Gain = 6dB	250	350	500	mV
f_{Beep}	Beep Frequency	f_{Beep1}	475	500	525	Hz
		f_{Beep2}	740	780	820	Hz
		f_{Beep3}	1.48	1.56	1.64	kHz
		f_{Beep4}	2.28	2.4	2.52	kHz

Table 4. Audioprocessor electrical characteristics (continued)
 ($V_S=9V$; $T_{amb}=25^{\circ}C$; $R_L=10k\Omega$; all gains=0dB; $f=1kHz$; unless otherwise specified)

Symbol	Parameter	Test Condition	Min.	Typ.	Max.	Unit
MIXING CONTROL						
M_{LEVEL}	Mixing Ratio	Main / Mix-Source		-6/-6		dB
G_{MAX}	Max. Gain		13	15	17	dB
A_{MAX}	Max. Attenuation		-83	-79	-75	dB
A_{STEP}	Attenuation Step		0.5	1	1.5	dB
LOUDNESS CONTROL						
A_{STEP}	Step Resolution		0.5	1	1.5	dB
A_{MAX}	Max. Attenuation		-21	-19	-17	dB
f_{Peak}	Peak Frequency	f_{P1}	180	200	220	Hz
		f_{P2}	360	400	440	Hz
		f_{P3}	540	600	660	Hz
		f_{P4}	720	800	880	Hz
VOLUME CONTROL						
G_{MAX}	Max. Gain		30	32	34	dB
A_{MAX}	Max. Attenuation		-83	-79	-75	dB
A_{STEP}	Step Resolution		0	0.5	1	dB
E_A	Attenuation Set Error	$G = -20$ to $+20$ dB	-0.75	0	+0.75	dB
		$G = -80$ to -20 dB	-4	0	3	dB
E_T	Tracking Error				2	dB
V_{DC}	DC Steps	Adjacent Attenuation Steps		0.1	3	mV
		From 0dB to G_{MIN}		0.5	5	mV

Table 4. Audioprocessor electrical characteristics (continued)
 ($V_S=9V$; $T_{amb}=25^\circ C$; $R_L=10k\Omega$; all gains=0dB; $f=1kHz$; unless otherwise specified)

Symbol	Parameter	Test Condition	Min.	Typ.	Max.	Unit
SOFT MUTE						
A_{MUTE}	Mute Attenuation		80	100		dB
T_D	Delay Time	T1		0.48	1	ms
		T2		0.96	2	ms
		T3	70	123	170	ms
		T4	200	324	600	ms
$V_{TH\ low}$	Low Threshold for SM-Pin ¹⁾				1	V
$V_{TH\ high}$	High Threshold for SM - Pin		2.5			V
R_{PU}	Internal pull-up resistor		32	45	58	k Ω
V_{PU}	Internal pull-up Voltage			2.3		V
EQUALIZER CONTROL						
C_{RANGE}	Control Range		± 14	± 15	± 16	dB
A_{STEP}	Step Resolution		0.5	1	1.5	dB
f_{C1}	Center Frequency Band 1	f_{C1a}	55	62	69	Hz
		f_{C1b}	90	100	110	Hz
f_{C2}	Center Frequency Band 2	f_{C2}	141	157	173	Hz
f_{C3}	Center Frequency Band 3	f_{C3}	365	396	437	Hz
f_{C4}	Center Frequency Band 4	f_{C4}	0.9	1	1.1	kHz
f_{C5}	Center Frequency Band 5	f_{C5}	2.25	2.51	2.766	kHz
f_{C6}	Center Frequency Band 6	f_{C6a}	3.6	4	4.4	kHz
		f_{C6b}	5.70	6.34	6.98	kHz
f_{C7}	Center Frequency Band 7	f_{C7a}	13.5	15	16.5	kHz
		f_{C7b}	14.4	16	17.6	kHz
Q	Quality Factor	Q_1	0.9	1	1.1	
		Q_2	1.26	1.4	1.54	
		Q_3	1.62	1.8	1.98	
		Q_4	1.98	2.2	2.44	
DC_{GAIN}	DC-gain, Band 1	DC = off	-1	0	+1	dB
		DC = on, 15dB boost		4		dB
SPECTRUM ANALYZER CONTROL						
V_{SAOut}	Output Voltage Range		0		3.3	V
f_{C1}	Center Frequency Band 1	f_{C1}	55	62	69	Hz
f_{C2}	Center Frequency Band 2	f_{C2}	141	157	173	Hz

Table 4. Audioprocessor electrical characteristics (continued)
 ($V_S=9V$; $T_{amb}=25^{\circ}C$; $R_L=10k\Omega$; all gains=0dB; $f=1kHz$; unless otherwise specified)

Symbol	Parameter	Test Condition	Min.	Typ.	Max.	Unit
f_{C3}	Center Frequency Band 3	f_{C3}	356	396	436	Hz
f_{C4}	Center Frequency Band 4	f_{C4}	0.9	1	1.1	kHz
f_{C5}	Center Frequency Band 5	f_{C5}	2.26	2.51	2.76	kHz
f_{C6}	Center Frequency Band 6	f_{C6}	5.70	6.34	6.98	kHz
f_{C7}	Center Frequency Band 7	f_{C7}	14.4	16	17.6	kHz
Q	Quality Factor	Q_1	1.62	1.8	1.98	
		Q_2	3.15	3.5	3.85	
f_{SAClk}	Clock Frequency		1		100	kHz
t_{SAdel}	Analog Output Delay Time		2			μs
t_{repeat}	Spectrum Analyzer Repeat Time		50			ms
t_{intres}	Internal Reset Time			3		ms
PAUSE DETECTOR						
V_{TH}	Zero Crossing Threshold	Window 1		40		mV
		Window 2		80		mV
		Window 3		160		mV
I_{DELAY}	Pull-Up Current		15	25	35	μA
V_{THP}	Pause Threshold			3		V
SPEAKER ATTENUATORS						
R_{in}	Input Impedance		35	50	65	$k\Omega$
G_{MAX}	Max. Gain		14.5	15.5	16.5	dB
A_{MAX}	Max. Attenuation		-83.5	-79.5	-75	dB
A_{STEP}	Step Resolution		0.5	1	1.5	dB
A_{MUTE}	Output Mute Attenuation		80	90		dB
ϵ_F	Attenuation Set Error				3	dB
V_{DC}	DC Steps	Adjacent Attenuation Steps		0.5	5	mV
M_R	Mixing Ratio	Signal/Mix _{in}		50/50		%
AUDIO OUTPUTS						
V_{CLIP}	Clipping Level	Thd=0.3%	2.2	2.6		V_{RMS}
R_L	Output Load Resistance		2			$k\Omega$
C_L	Output Load Capacitance				10	nF
R_{OUT}	Output Impedance			30	120	W
V_{DC}	DC Voltage Level		4.3	4.5	4.7	V

Table 4. Audioprocessor electrical characteristics (continued)
 ($V_S=9V$; $T_{amb}=25^{\circ}C$; $R_L=10k\Omega$; all gains=0dB; $f=1kHz$; unless otherwise specified)

Symbol	Parameter	Test Condition	Min.	Typ.	Max.	Unit
HIGH PASS						
f_{HP}	Highpass corner frequency	f_{HP1}	81	90	99	Hz
		f_{HP2}	122	135	148	Hz
		f_{HP3}	162	180	198	Hz
		f_{HP4}	194	215	236	Hz
SUBWOOFER ATTENUATOR						
R_{in}	Input Impedance		35	50	65	Ω
G_{MAX}	Max. Gain		14	15	16	dB
A_{ATTN}	Max. Attenuation		-83	-79	-75	dB
A_{STEP}	Step Resolution		0	1	1.5	dB
A_{MUTE}	Output Mute Attenuation		80	90		dB
E_E	Attenuation Set Error				2	dB
V_{DC}	DC Steps	Adjacent Attenuation Steps		1	5	mV
SUBWOOFER Lowpass						
f_{LP}	Lowpass corner frequency	f_{LP1}	72	80	88	Hz
		f_{LP2}	108	120	132	Hz
		f_{LP3}	144	160	176	Hz
GENERAL						
e_{NO}	Output Noise	BW = 20Hz - 20kHz output muted		3	15	μV
		BW = 20Hz - 20kHz all gains = 0dB single ended inputs		10	20	μV μV
S/N	Signal to Noise Ratio	all gains = 0dB flat; $V_O = 2V_{RMS}$		103		dB
		All EQ-bands at +12dB; Q = 1.0 a-weighted; $V_O = 2.6V_{RMS}$		87		dB
d	distortion	$V_{IN} = 1V_{RMS}$; all stages 0dB		0.01	0.1	%
		$V_{OUT} = 1V_{RMS}$; Bass & Treble = 12dB		0.05	0.1	%
S_C	Channel Separation left/right		80	90		dB

4 Description of the audioprocessor part

4.1 Input stages

In the basic configuration there is a source-Selector with 8 inputs: one pseudo-differential (CDC), three single ended stereo (MD, CD, Tape), three single-ended mono (PHONE, NAVI, TIM) plus the “tuner” input. The tuner input takes the signal from either MPX1 or MPX2/AM pins (through the stereodecoder) see [Figure 3](#).

4.1.1 Pseudo-differential stereo Input (PD)

The PD input is implemented as a buffered pseudo-differential stereo stage with 100k Ω input-impedance at each input pin. This input is also configurable as single-ended stereo input (CDC, see pin-out). The common input-pin, PD- features a fast charge switch to speed up the charge time of external capacitors. This switch is released the first time the input-selector data-byte (0) is assessed.

4.1.2 Single-ended stereo Inputs, single-ended mono inputs and FM-MPX input

All single ended inputs have an input impedance of 100k Ω . The AM-pin can be connected to the input of the stereo-decoder in order to use the AM-noiseblanker and AM-High-Cut feature. As input “Tuner” for the input selector either the stereo-decoder output or the AM-pin is selectable.

4.1.3 Mixing Selector

It is possible to enable/disable the mixing feature (ratio 50%) at the outputs stages between whichever input source and one of the following signals: Beep, Phone, Navigator and Tuner/TIM.

4.1.4 Beep Generator

There are four possible selectable beeping frequencies: 600Hz, 780Hz, 1.56KHz and 2.4KHz.

Figure 3. Input-stages

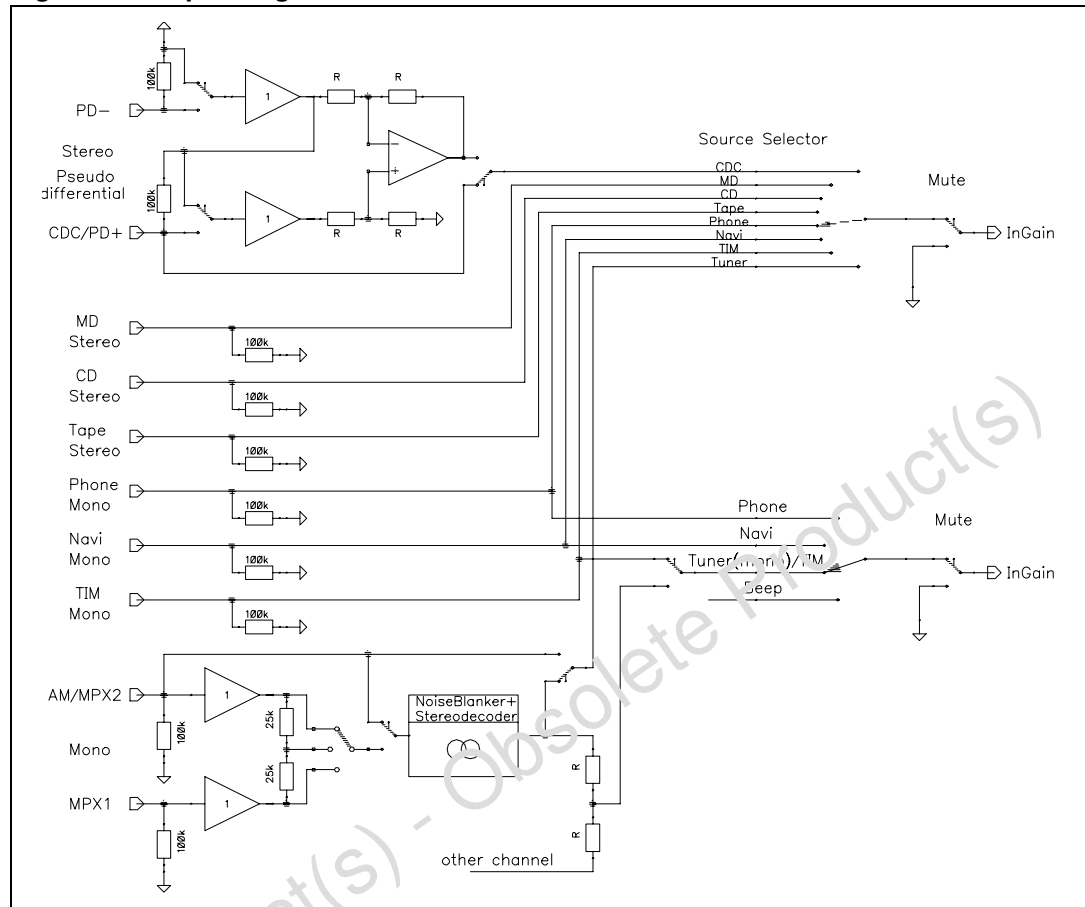

4.2 AutoZero

The AutoZero allows a reduction of the number of pins as well as external components by canceling any offset generated by or before the In-Gain-stage (Please notice that externally generated offsets, e.g. generated through the leakage current of the coupling capacitors, are not canceled).

The auto-zeroing is started every time the DATA-BYTE 0 is selected and needs max. **0.3ms** for the alignment. To avoid audible clicks the Audioprocessor have to be muted by soft mute or hard mute during this time.

4.2.1 AutoZero for Stereodecoder-Selection

A special procedure is recommended for selecting the stereodecoder at the input-selector to guarantee an optimum offset-cancellation:

(Step 0: SoftMute or Mute the signal-path)

- Step 1: Temporary deselect the stereodecoder at the input-selector
- Step 2: Configure the stereodecoder via IIC-Bus
- Step 3: Wait 1ms
- Step 4: Select the stereodecoder

The root cause of this procedure is, that after muting the stereodecoder (Step 1), the internal stereodecoder filters have to settle in order to perform a proper offset-cancellation.

4.2.2 AutoZero-Remain

In some cases, for example if the μP is executing a refresh cycle of the IIC-Bus-programming, it is not useful to start a new AutoZero-action because no new source is selected and an undesired mute would appear at the outputs. For such applications the TDA7406 could be switched in the **AutoZero-Remain-Mode** (Bit 6 of the subaddress-byte). If this bit is set to high, the DATABYTE 0 could be loaded without invoking the AutoZero and the old adjustment-value remains.

4.2.3 PAUSE Detector

A pause detector stage with programmable threshold (40/80/160mV) is provided (see data Byte 14).

The pause detector info is available at the PAUSE pin; a capacitor must be connected between this pin and GND.

When the incoming signal is detected to be outside the selected window, the external capacitor is discharged. When the signal is inside the window, the capacitor is integrating up.

The pause status can be detected in two ways:

- a) reading directly the PAUSE pin level
Pause Off = level low ($<3.0\text{V}$)
Pause On = level high ($>3.0\text{V}$)
- b) by reading the I2C transmitted byte, bit P
P = 1 pause active
P = 0 no pause detected

The external capacitor value fixes the time constant. The pull up current is $25\mu\text{A}$ typical.

4.3 Loudness

There are four parameters programmable in the loudness stage:

- **Attenuation:** 0 to -19dB attenuation in 1dB steps vs. frequency (see the response at $f_p = 400\text{Hz}$ in [Figure 4](#)).
- **Peak Frequency:** Four programmable peak frequencies: 200,400,600 and 800Hz (see [Figure 5](#)).
- **Filter Order:** First or second order frequency response (see [Figure 6](#)).
- **Flat mode:** Selectable flat-mode. In flat mode the loudness stage works as a 0dB to -19dB attenuator.

Figure 4. Loudness Attenuation @ $f_p = 400\text{Hz}$.

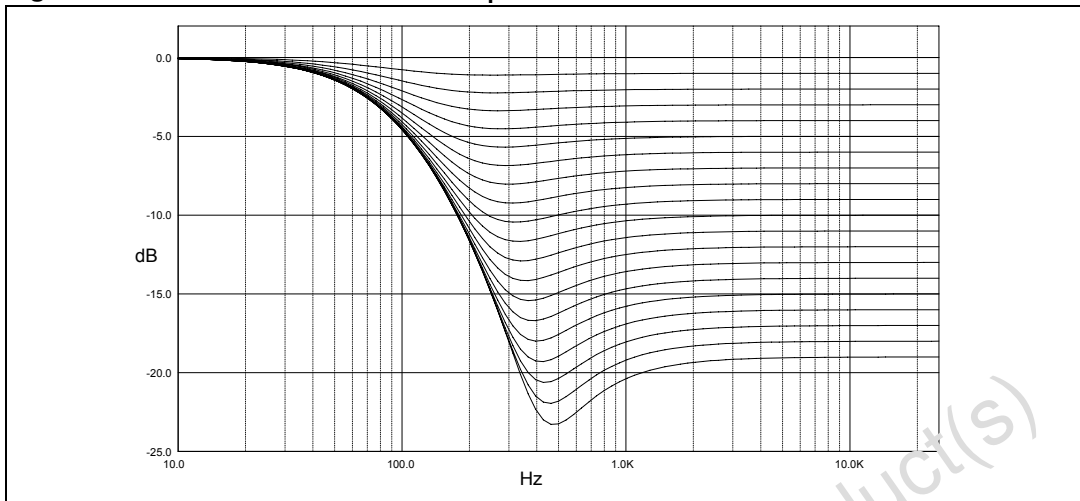

Figure 5. Loudness Center frequencies @ Attn. = 15dB

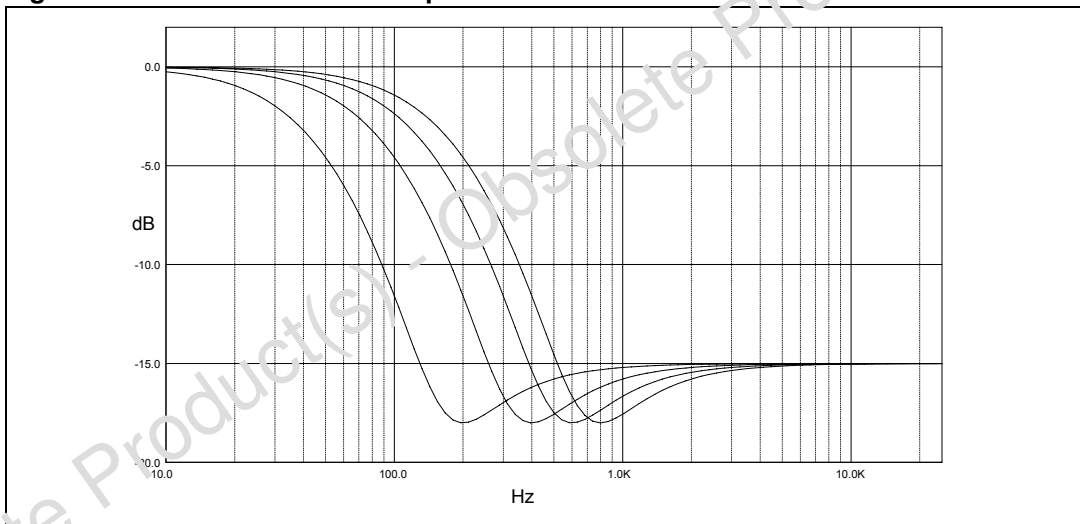
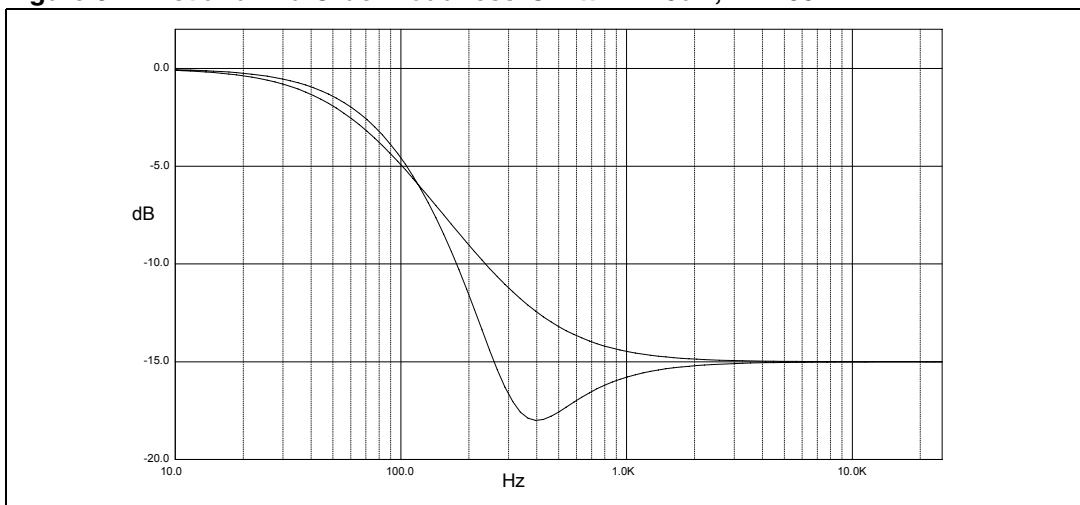

Figure 6. 1st and 2nd Order Loudness @ Attn. = 15dB, $f_p=400\text{Hz}$



4.4 Soft Mute

The digitally controlled Soft Mute stage allows signal muting/demuting with a programmable slope. The Mute time is selectable among 4 values: 0.48, 0.96, 123 and 324ms. The mute process can either be activated by the Soft Mute pin or via the I²C-bus. This slope is realized in a special S-shaped curve to mute slow in the critical regions (see [Figure 7](#)).

For timing purposes the I²C-bus output register (Bit0 = SM read bit) is set to 1 from the start of muting until the end of de-muting.

Figure 7. Soft Mute-Timing

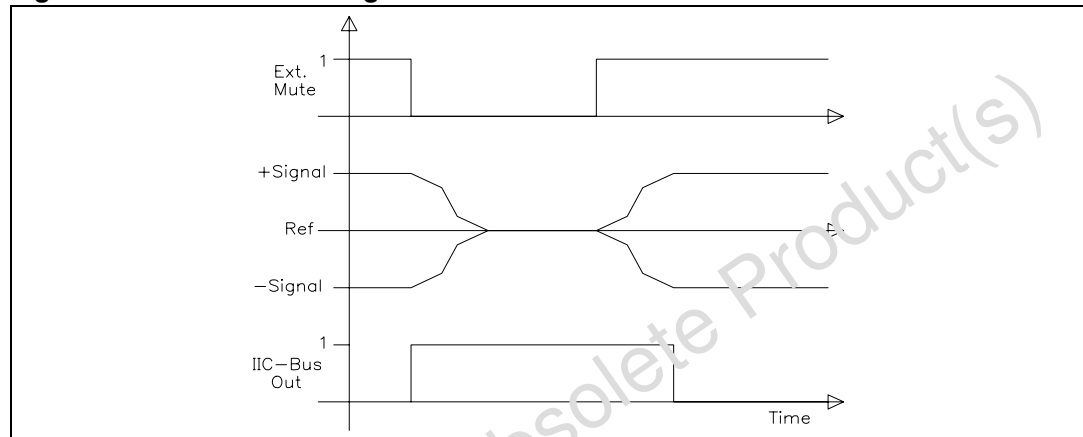

Note: Please notice that a started Mute-action is always terminated and could not be interrupted by a change of the mute -signal.

4.5 Volume Control

4.5.1 Gain/Attenuation Control

The volume control can range from a gain of 32dB up to an attenuation of 79dB; however it is not recommended to use a gain higher than 20dB for performance reasons.

4.5.2 Soft Step Volume

When the speaker-level is changed, audible clicks could appear at the output. The root cause of those clicks could either be a DC offset before the speaker-stage or the sudden change of the envelope of the audio signal. With the SoftStep-feature both kinds of clicks could be reduced to a minimum and are no more audible. The blend-time from one step to the next is programmable with four different values: 320μs, 1.28ms, 5.12ms and 20.4ms.

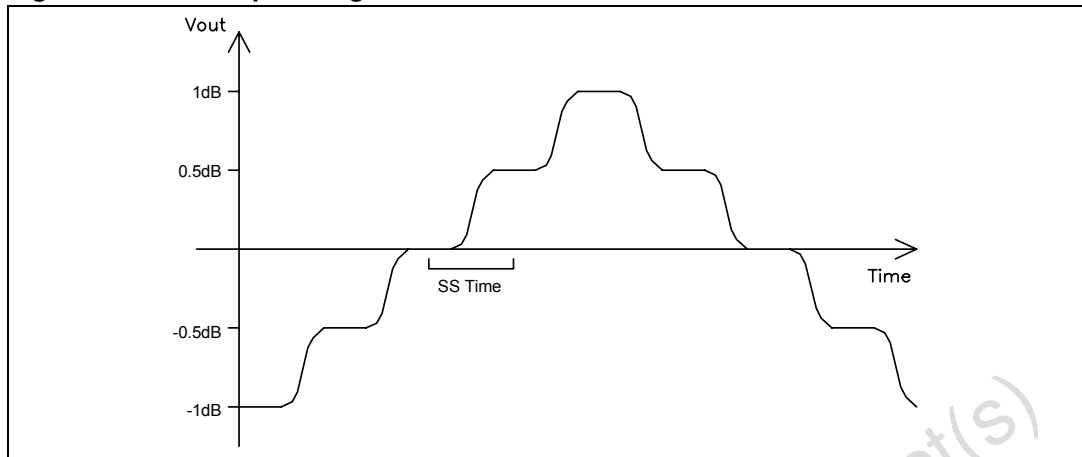
Figure 8. SoftStep-Timing for Volume

Note: For steps more than 0.5dB (Volume) or 1dB (Speaker) the SoftStep mode should be deactivated because it could generate a hard 1dB step during blending.

4.6 The Seven Band Equalizer

4.6.1 Equalizer Filter

Each filter is realized as a switched capacitor with a 2nd order frequency response.

There are three parameters programmable in the equalizer filter:

- **Attenuation:** ± 15 dB in 1dB step resolution (*Figure 9* shows the boost and cut response as a function of frequency at a center frequency of 1kHz.)
- **Center Frequency:** This parameter is programmable in the filter stages 1 (62/100Hz), 6 (4/6.34kHz) and 7 (15/16kHz). The others bands are fixed at: 157, 396, 1K and 2.5K Hertz (see *Figure 10*).
- **Quality Factors:** The four possible quality factors are 1, 1.4, 1.8 and 2.2 (see *Figure 11*).

The center frequency, Q, DC-mode and boost/cut can be set fully independently for each filter. *Figure 12* shows the superposition of all equalizer filter curves for different quality factors.

Figure 9. Equalizer filter control @ $f_{Center} = 1\text{kHz}$, $Q = 1.0$

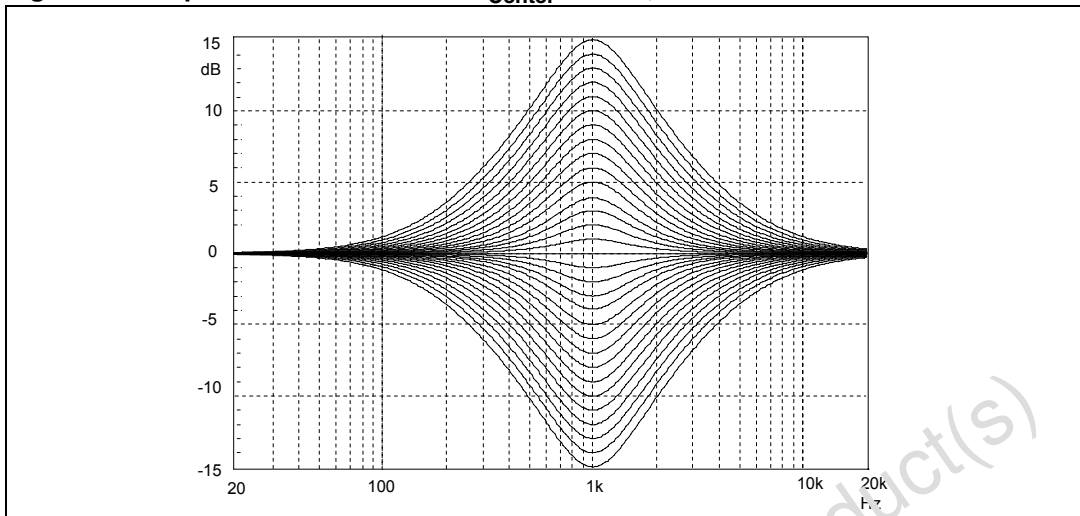

Figure 10. Center frequencies @ Gain = 15dB, $Q = 1.0$

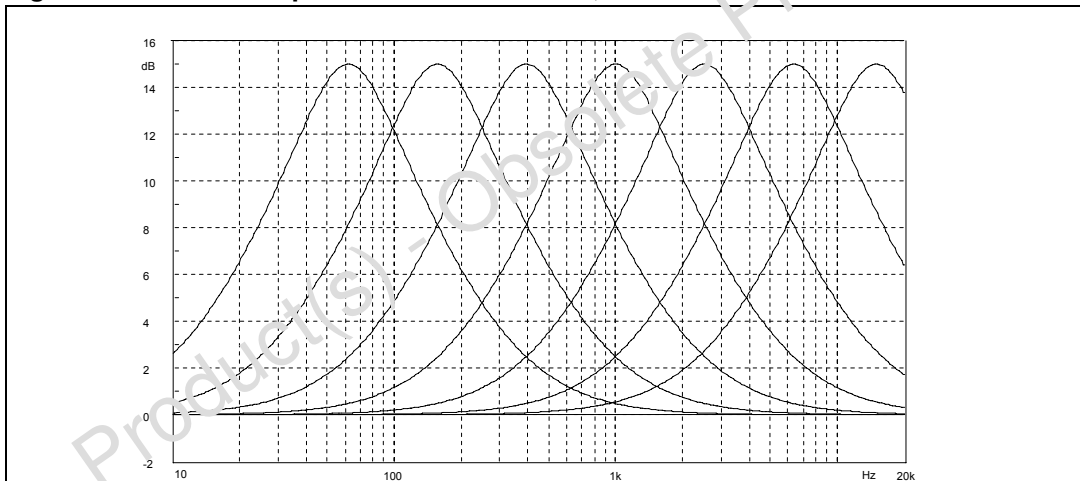

Figure 11. Quality factors @ boost = 15dB, $f_{Center} = 1\text{kHz}$

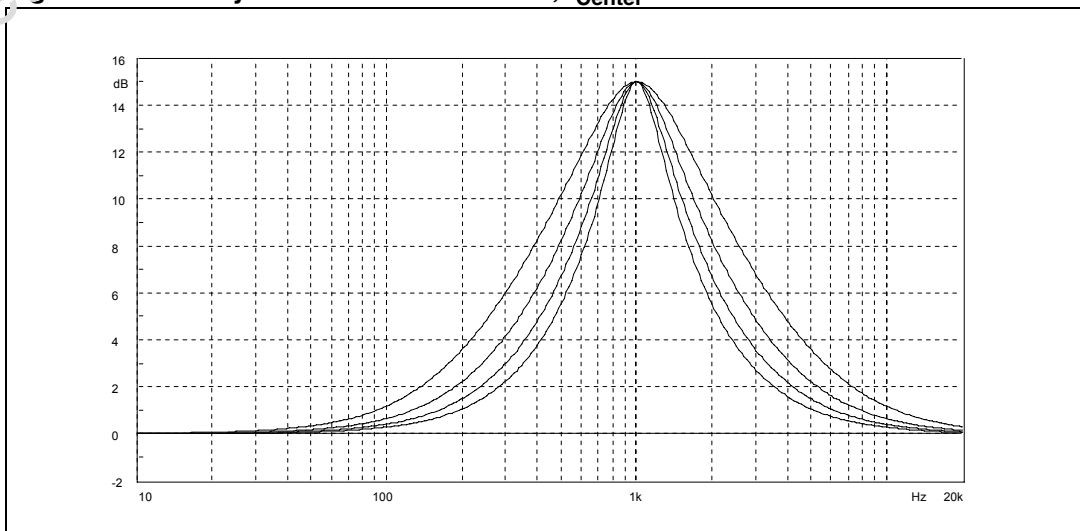
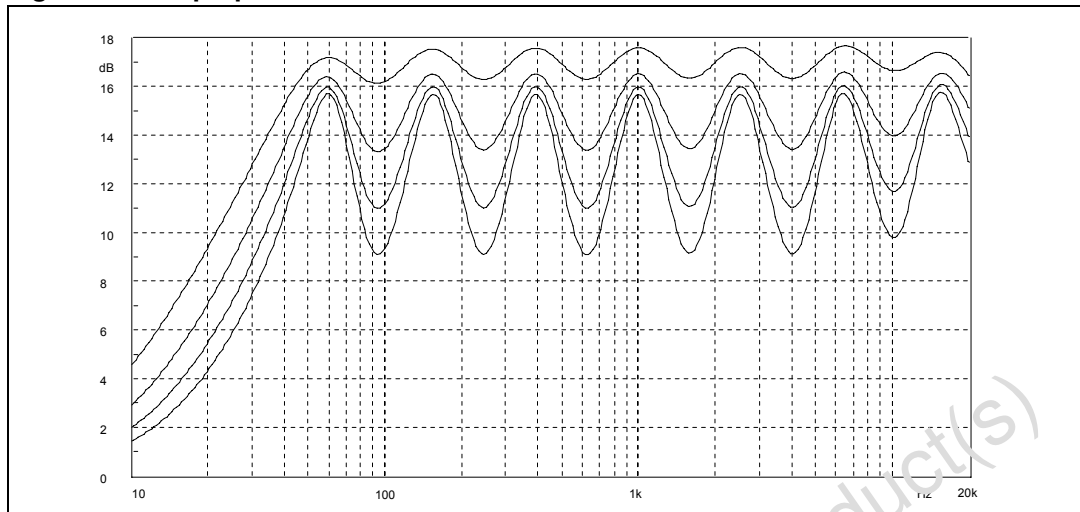
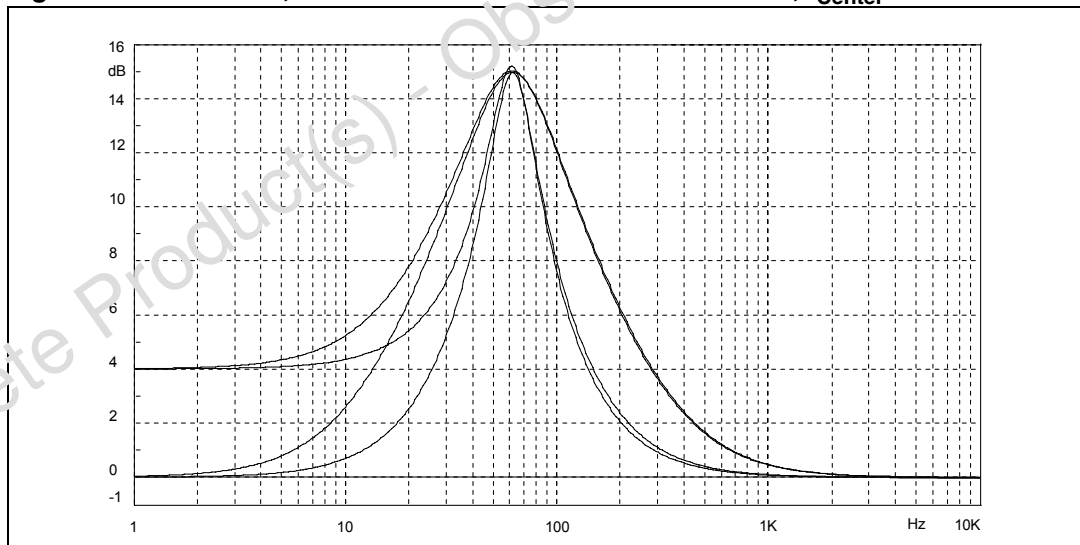

Figure 12. Superposition of all EQ bands @ boost = 15dB



4.6.2 DC-Mode

The filter stage 1 (62/100Hz) has a programmable +4dB DC-gain when the boost is set at +15dB (See [Figure 13](#)).

Figure 13. EQ band1, normal- and DC-mode @ boost = 15 dB, $f_{\text{Center}} = 62 \text{ Hz}$ 

Note: The center frequency, Q, DC-mode and boost/cut can be set fully independently for each filter.

4.7 Subwoofer Application

There is one separate subwoofer output. A low-pass filter stage at this output allows the selection of three different frequencies: 80/120/160Hz. A high Pass Filter stage is present in the main path with selectable 90/135/180/215Hz frequencies. Both filters, the low-pass as well as the high-pass filter can be disabled and have butterworth characteristics so that their

cutoff frequencies are not equal but shifted by the factor 1.125 to get a flat frequency response (see [Figure 14](#)).

Figure 14. Subwoofer Application with Lowpass @ 80/120/160Hz and HighPass @ 90/135/180Hz

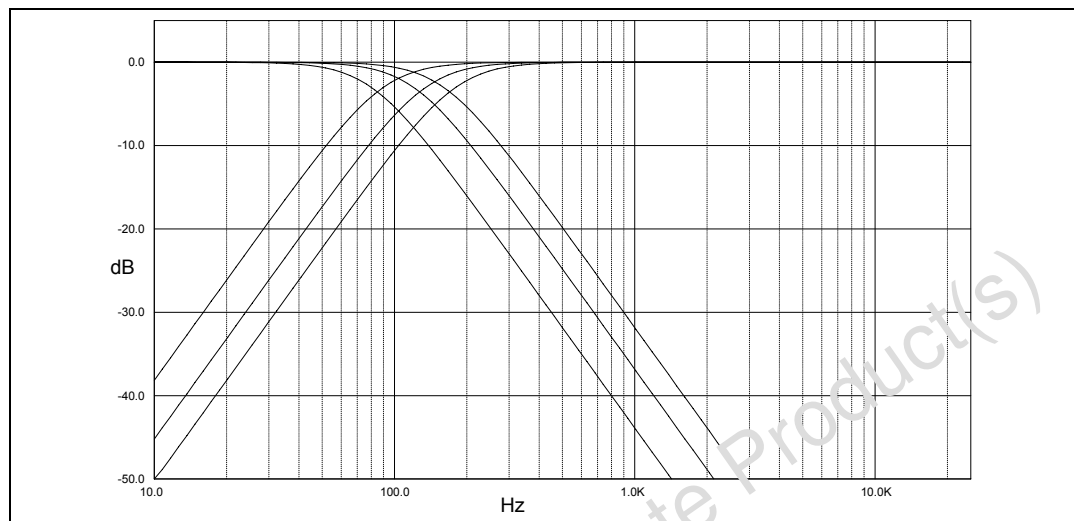

4.8 Spectrum analyzer

A fully integrated seven band spectrum analyzer with programmable quality factor is present in the IC ([Figure 15](#)).

The spectrum analyzer consists of seven band pass filters with a rectifier and sample capacitor which stores the maximum peak signal level since the last read cycle. This peak signal level can be read by a microprocessor at the SA_{out} pin. To allow easy interfacing to a microprocessor analog port, the output voltage at this pin is referred to device ground.

The microprocessor starts a read cycle when there is a clock edge going negative at the SA_{clk} input. On the following positive clock edges, the peak signal level for the band pass filters is subsequently switched to SA_{out}. Each analog output data is valid after the time t_{SAdel} .

A reset of the sample capacitors is induced whenever SA_{clk} remains high for the time t_{intres} . Note that a proper reset requires the clock signal SA_{clk} to be held at high potential. [Figure 15](#) shows the block diagram and [Figure 16](#) illustrates the read cycle timing of the spectrum analyzer.

The spectrum analyzer minimum repeat time is 50ms.

4.8.1 Spectrum Analyzer Filters

Each filter is realized as a switched capacitor with a 2nd order frequency response. The center frequency of the filter stages are: 62, 157, 396, 1K, 2.51K, 6.34k and 16kHz. It is possible to choose between two different filter quality factors: 1.8 and 3.5.

Figure 15. Spectrum analyzer block diagram

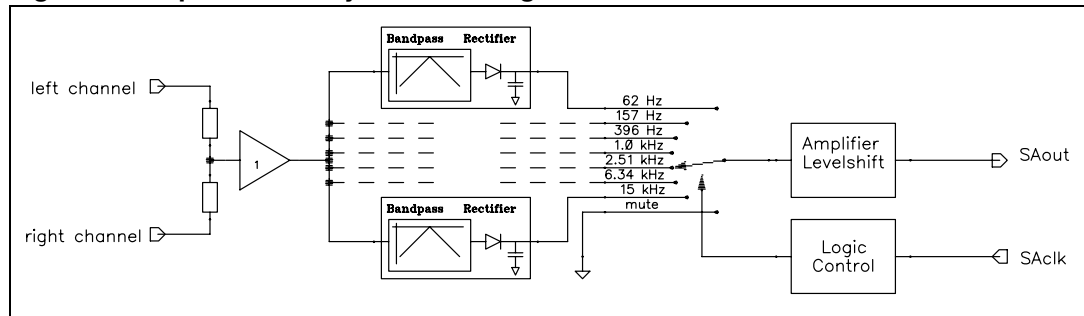
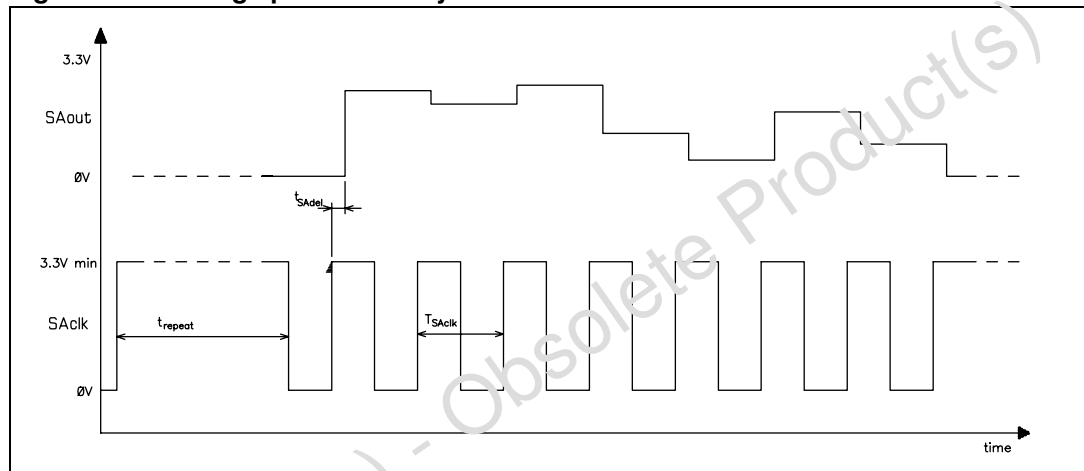

Figure 16. Timing spectrum analyzer



4.9 AC-coupling

In some applications additional signal manipulations are desired. For this purpose an AC-coupling is placed before the speaker-attenuators, which can be activated or internally shorted by I²C-Bus. In short condition the input-signal of the speaker-attenuator is available at the AC-outputs. The input-impedance of this AC-inputs is 50k Ω . In addition there are Mix_{In} inputs available. With this inputs it is possible to mix an external signal to every speaker with a mixing ratio of 50% (see [Figure 17](#)).

The source of front and rear speaker can be set independently. As source is possible to choose:

- internal dc coupling (not recommended)
- external ac coupling using AC_{In} pins
- external ac coupling using Mix_{In} pins
- mixing of AC_{In} and Mix_{In} pins (mixing ratio: 50%)

If the Mix_{In} pins of the rear speaker are not used this inputs can be used as mixing inputs for the internal subwoofer filter.