



Chipsmall Limited consists of a professional team with an average of over 10 year of expertise in the distribution of electronic components. Based in Hongkong, we have already established firm and mutual-benefit business relationships with customers from,Europe,America and south Asia,supplying obsolete and hard-to-find components to meet their specific needs.

With the principle of “Quality Parts,Customers Priority,Honest Operation,and Considerate Service”,our business mainly focus on the distribution of electronic components. Line cards we deal with include Microchip,ALPS,ROHM,Xilinx,Pulse,ON,Everlight and Freescale. Main products comprise IC,Modules,Potentiometer,IC Socket,Relay,Connector.Our parts cover such applications as commercial,industrial, and automotives areas.

We are looking forward to setting up business relationship with you and hope to provide you with the best service and solution. Let us make a better world for our industry!



Contact us

Tel: +86-755-8981 8866 Fax: +86-755-8427 6832

Email & Skype: info@chipsmall.com Web: www.chipsmall.com

Address: A1208, Overseas Decoration Building, #122 Zhenhua RD., Futian, Shenzhen, China





TDA7463A

LOW VOLTAGE TONE CONTROL DIGITALLY CONTROLLED AUDIO PROCESSOR

1 FEATURES

- 2 STEREO INPUT
- 1 STEREO OUTPUT
- TREBLE BOOST
- BASS CONTROL
- BASS AUTOMATIC LEVEL CONTROL
- VOLUME CONTROL IN 1dB STEPS
- MUTE
- STAND-BY FUNCTION SOFTWARE CONTROLLED
- ALL FUNCTIONS ARE PROGRAMMABLE VIA SERIAL BUS

2 DESCRIPTION

The TDA7463A is a volume tone (bass and treble) processor for quality audio applications in Low voltage supply portable systems.

Bass ALC (Automatic Level Control) function can

Figure 1. Package

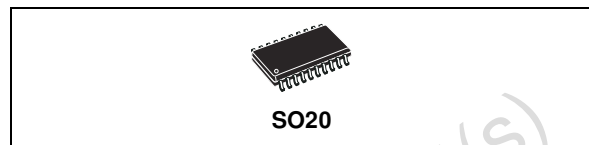

Table 1. Order Codes

Part Number	Package
TDA7463A	SO20

be adjusted by a dedicated pin. The control of all the functions is accomplished by serial bus.

The AC signal setting is obtained by resistor networks and switches combined with operational amplifiers.

Thanks to the used BIPOLAR/CMOS Technology, Low Distortion, Low Noise and DC stepping are obtained.

Figure 2. Application & Test Circuit

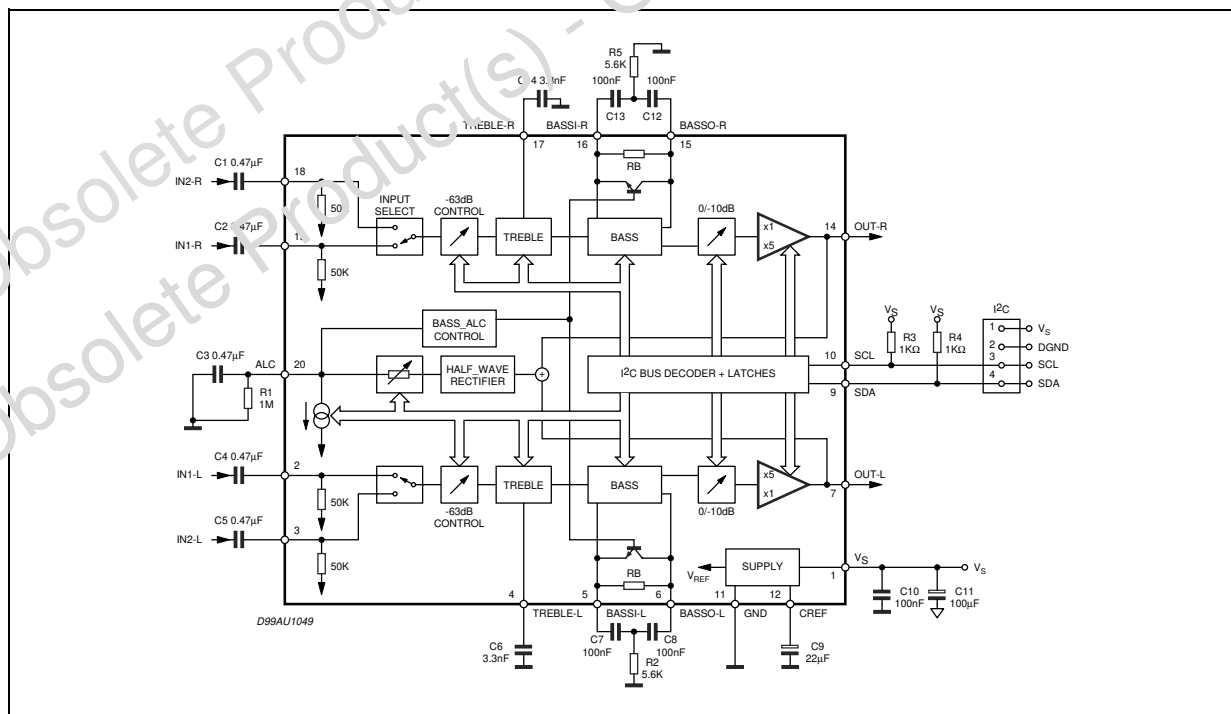

Table 2. Absolute Maximum Ratings

Symbol	Parameter	Value	Unit
V _S	Operating Supply Voltage	5	V
T _{amb}	Operating Ambient Temperature	0 to 70	°C
T _{stg}	Storage Temperature Range	-55 to 150	°C

Figure 3. Pin Connection

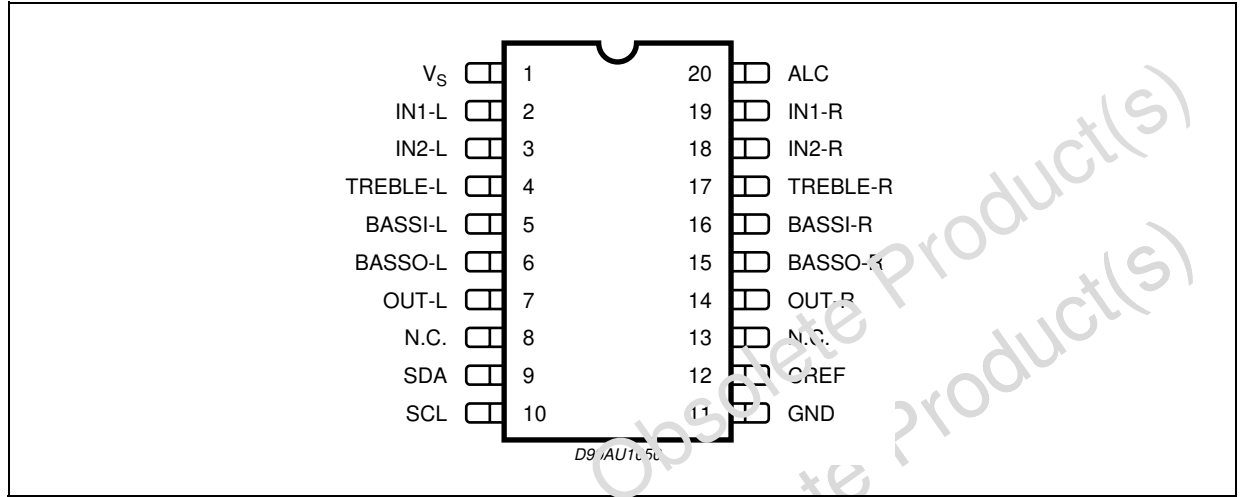

Table 3. Thermal Data

Symbol	Parameter	Value	Unit
R _{th j-pin}	Thermal Resistance Junction-pins	85	°C/W

Table 4. Quick Reference Data

Symbol	Parameter	Test Condition	Min.	Typ.	Max.	Unit
V _S	Supply voltage		1.8	2.4	3	V
V _{CL}	Max. input signal handling		0.2			V _{rms}
THD	Total Harmonic Distortion	V = 0.1V _{rms} ; f = 1KHz			0.1	%
S/N	Signal to Noise Ratio	V _{out} = 0.1V _{rms} (mode = OFF)		80		dB
Sc	Channel Separation	f = 1KHz		80		dB
	Volume control	(1dB step)	-63		0	dB
		-10dB damping	-10		0	dB
		-14dB	0		14	dB
		Treble Control	0		8	dB
		Bass Control	0		14	dB
		mute attenuation		100	8	dB

Table 5. Electrical Characteristics (refer to the test circuit $T_{amb} = 25^{\circ}\text{C}$, $V_S = 2.4\text{V}$, $R_L = 10\text{K}\Omega$, $R_G = 600\Omega$, all controls flat, unless otherwise specified)

Symbol	Parameter	Test Condition	Min.	Typ.	Max.	Unit
SUPPLY						
V _S	Supply Voltage		1.8	2.4	3	V
I _S	Supply Current			4		mA
I _{ST-BY}	Stand-By Current			50		μA
S _{VR}	Ripple Rejection			70		dB
INPUT STAGE						
R _{IN}	Input Resistance		35	50	65	KΩ
V _{CL}	Clipping Level	THD = 0.3%	0.2			V _{rms}
VOLUME CONTROL						
C _{RANGE}	Control Range			0		dB
A _{V MIN}	Min Attenuation		-1	0	1	dB
A _{V MAX}	Max. Attenuation		62	63	64	dB
A _{STEP}	Step Resolution			1		dB
A _{mute}	Mute Attenuation		80	100		dB
A-10dB	-10dB damping			10		dB
G14dB	14dB gain			14		dB
BASS CONTROL (1)						
G _b	Control Range	Max. Boost/on		14		dB
R _B	Internal Feedback Resistance		33.75	45	56.25	KΩ
TREBLE CONTROL (1)						
G _t	Control Range	Max. Boost on		8		dB
AUDIO OUTPUTS						
V _{CLIP}	Clipping Level	d = 0.3%	0.2			V _{RMS}
R _L	Output Load Resistance		10			KΩ
V _{DC}	DC voltage Level			0.8		V
GENERAL						
E _{NO}	Output Noise	Output Muted All gains = 0dB; BW = 20Hz to 20KHz flat		5 8		μV μV
E _t	Total Tracking Error			0	1	dB
S/N	Signal to Noise Ratio	All gains 0dB; V _O = 0.1V _{RMS} ;		80		dB
SC	Channel Separation Left/Right			80		dB
d	Distortion	A _V = 0; V _I = 0.1V _{RMS} ;			0.1	%
BUS INPUT						
V _{IL}	Input Low Voltage				0.5	V
V _{IH}	Input High Voltage		1.9			V
I _{IN}	Input Current	V _{IN} = 0.4V	-5		5	μA
V _O	Output Voltage SDA Acknowledge	I _O = 1.6mA			0.4	V

Note: 1. BASS and TREBLE response: The center frequency and the response quality can be chosen by the external circuitry.

3 DATA BYTES

Address = (HEX) 10001000

Table 6. FUNCTION SELECTION:

The first byte (subaddress)58

MSB				LSB				SUBADDRESS
D7	D6	D5	D4	D3	D2	D1	D0	
	X	X	B	0	0	0	0	STAND-BY & TREBLE & OTHERS
	X	X	B	0	0	0	1	BASS
	X	X	B	0	0	1	0	VOLUME

B = 1 incremental bus; active

B = 0 no incremental bus;

X = indifferent 0,1

Table 7. STAND_BY & TREBLE & OTHERS

MSB							LSB	
D7	D6	D5	D4	D3	D2	D1	D0	
								STAND-BY
							1	ALL CIRCUITS STOP
								TREBLE
						1		STAND-BY (Treble block stops)
					1	0		BOOST OFF
					0	0		BOOST ON
				1	0	0		High Boost (+8dB)
				0	0	0		Low Boost (+4dB)
								MUTE
			1					Input Mute ON
			0					Input Mute OFF
		1						Output Mute ON
		0						Output Mute OFF
								BASS
	1							Release Current Circuit ON
	0							Release Current Circuit OFF
								INPUT Select
1								INPUT 1
0								INPUT 2

Table 8. BASS

MSB							LSB	BASS
D7	D6	D5	D4	D3	D2	D1	D0	
							1	STAND-BY (Bass block stops)
						1		BASS (boost OFF)
						0		BASS (boost ON)
					1	0		High boost (Ex. + 14dB)
					0	0		Low boost (Ex. + 6dB)
				1				ALC mode OFF (ALC block stops)
				0				ALC mode ON
		0	0					Attack time resistor (12.5K Ω) Release current (0.4 μ A)
		0	1					Attack time resistor (25K Ω) Release current (0.2 μ A)
		1	0					Attack time resistor (50K Ω) Release current (0.1 μ A)
		1	1					Attack time resistor (100K Ω) Release current (0.05 μ A)
0	0							Threshold1 (0.2Vrms)
0	1							Threshold2 (0.14Vrms)
1	0							Threshold3 (0.1Vrms)
1	1							Threshold4 (0.07Vrms)

Table 9. VOLUME

MSB							LSB	VOLUME
D7	D6	D5	D4	D3	D2	D1	D0	1 dB STEPS
					0	0	0	0
					0	0	1	-1
					0	1	0	-2
					0	1	1	-3
					1	0	0	-4
					1	0	1	-5
					1	1	0	-6
					1	1	1	-7
								8 dB STEPS
		0	0	0				0
		0	0	1				-8
		0	1	0				-16
		0	1	1				-24
		1	0	0				-32
		1	0	1				-40
		1	1	0				-48
		1	1	1				-56
								OUTPUT GAIN
	1							0dB
	0							+14dB
								OUTPUT ATTENUATION
1								0dB
0								-10dB

VOLUME : 0 ~ -63dB

3.1 ALC IN general:

Table 10. VOLUME setting with ALC

Target Volume [dB]	Volume [dB]	Output Gain 0/+14dB0/-10dB [dB]	Output Attenuation 0/-10dB [dB]
0	-14	+14	0
-1	-15		
-2	-16		
-3	-17		
-4	-18		
-5	-19		
-6	-20		
-7	-21		
-8	-22		
-9	-23		
-10	-24		
-11	-25		
-12	-26		
-13	-27		
-14	-14	0	0
-15	-15		
-16	-16		
-17	-17		
-18	-18		
-19	-19		
-20	-20		
-21	-21		
-22	-22		
-23	-23		
-24	-14	0	-10
-25	-15		
-26	-16		
-27	-17		
:	:		
:	:		
-70	-60		
-71	-61		
-72	-62		
-73	-63		

Figure 4. PIN: IN-L, IN-R

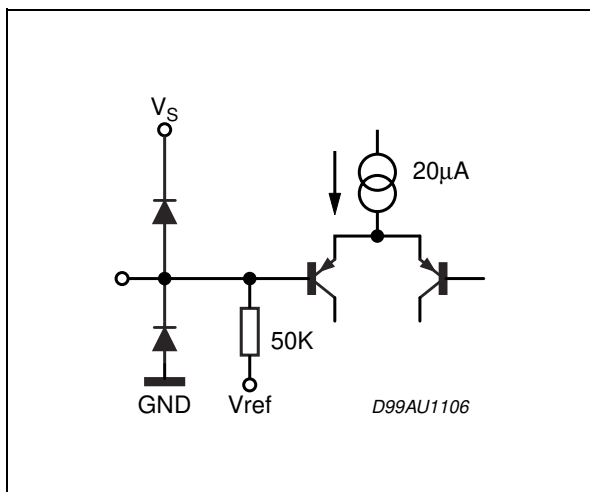

Figure 7. OUT-L, OUT-R

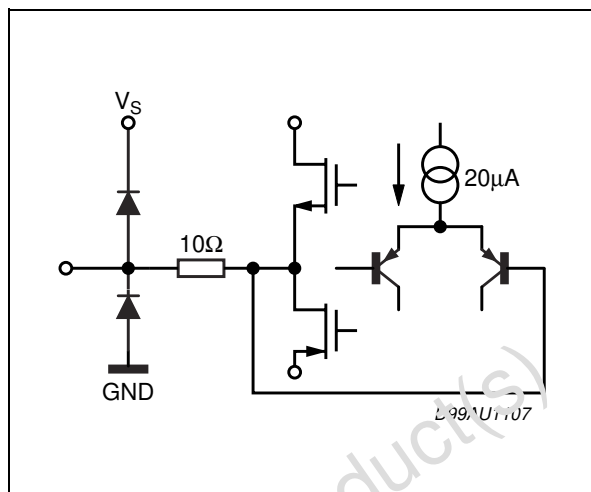

Figure 5. PIN: TREBLE-L, TREBLE-R

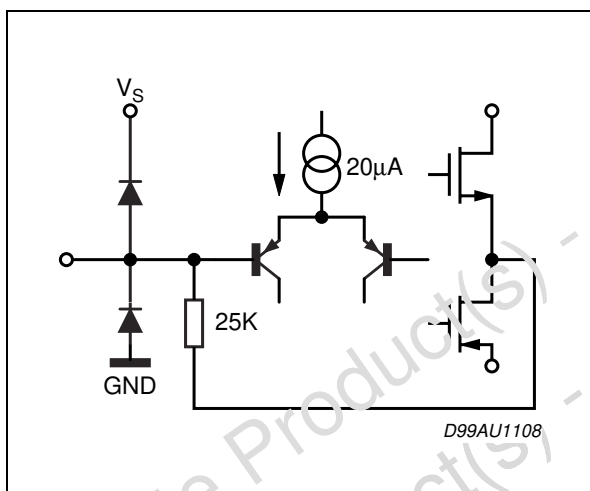

Figure 8. SCL, SDA

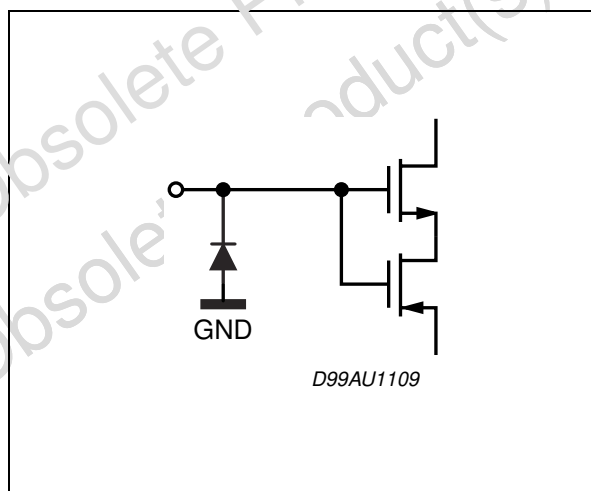

Figure 6. PIN: BASSI-L, BASSI-R

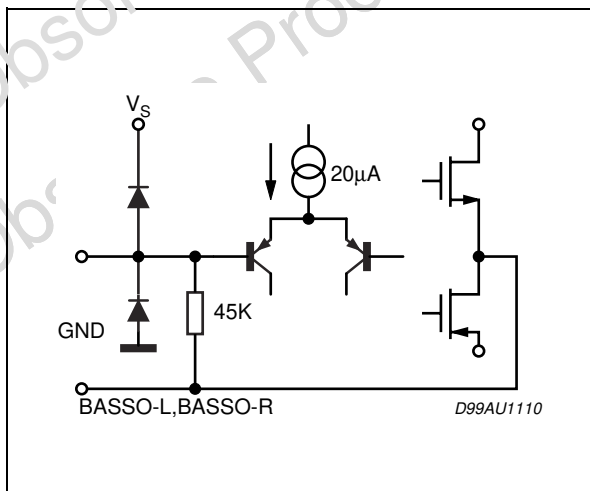

Figure 9. BASSO-L, BASSO-R

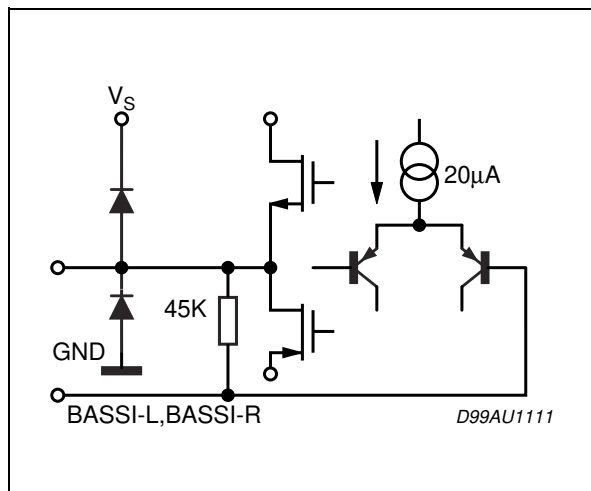

Figure 10. PIN: ALC

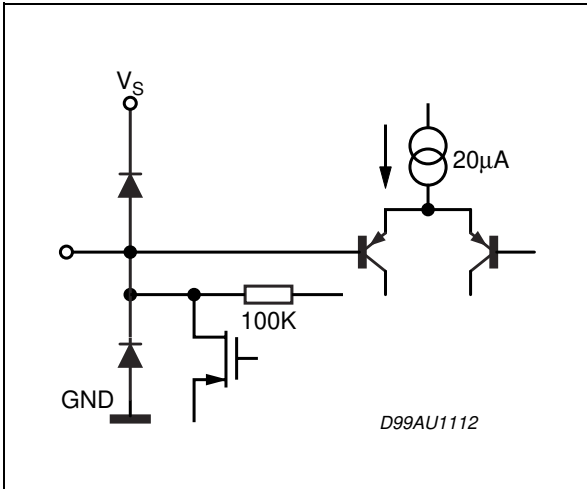

Figure 12. BASS ALC: Threshold curve

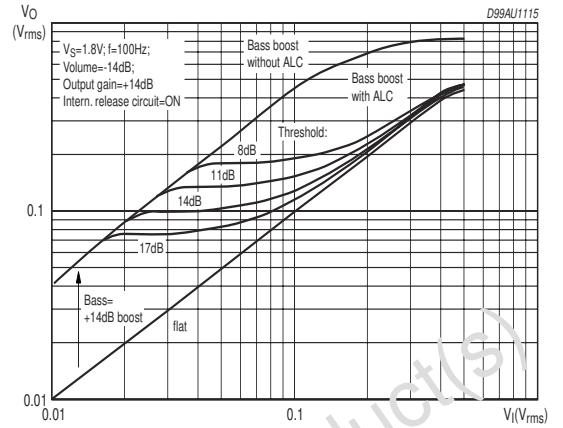

Figure 11. PIN CREF

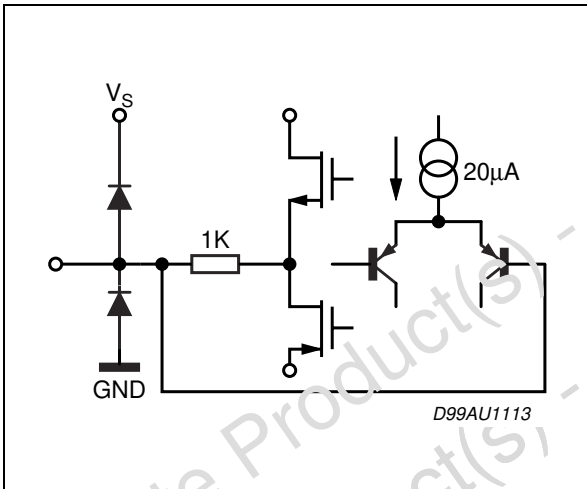

Figure 13. BASS ALC: THD

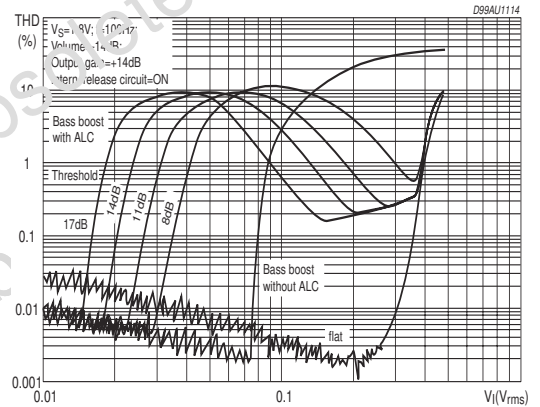

Figure 14. board and Components Layout of the Application & Test Circuit.

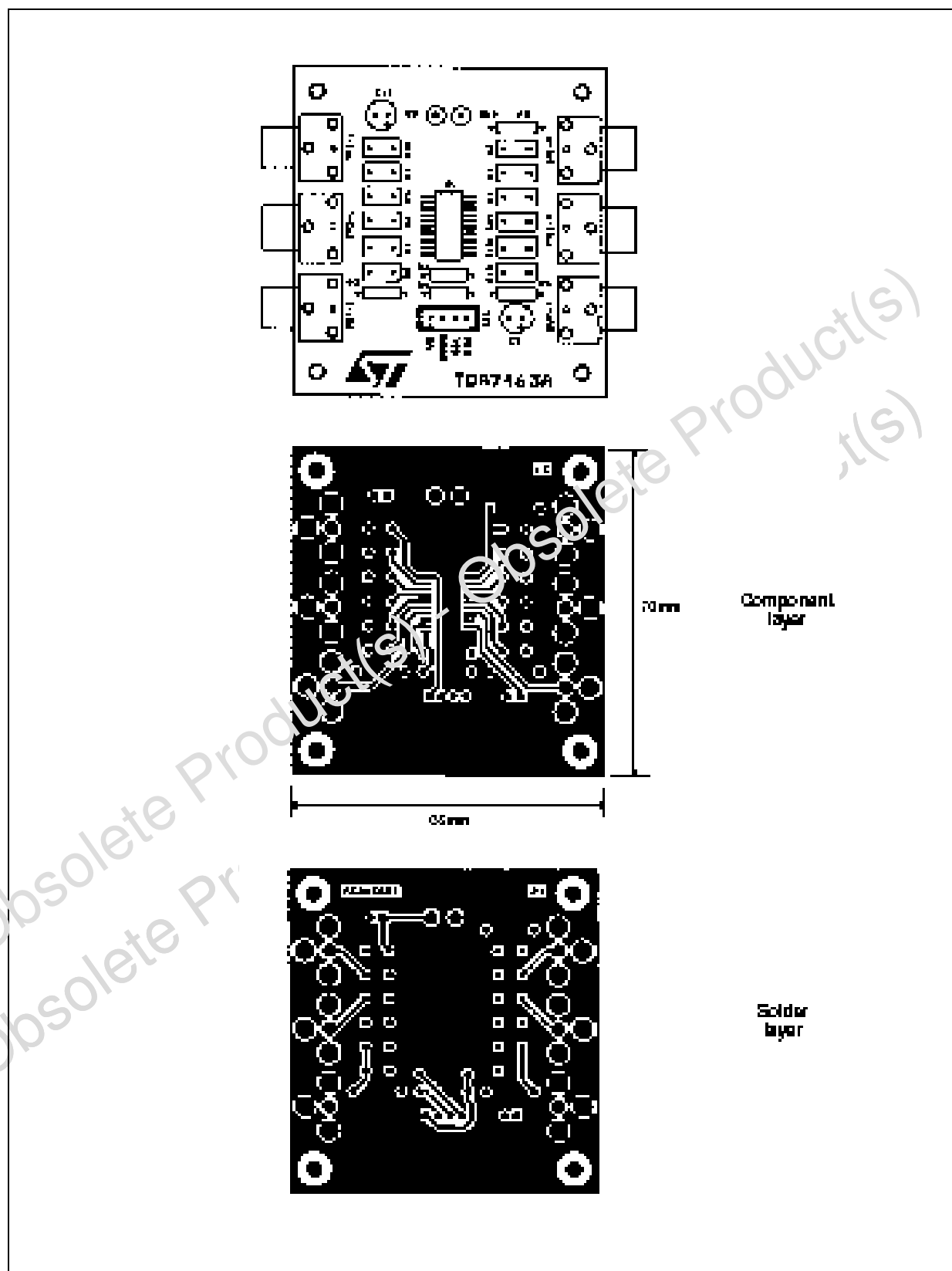

Table 11. Revision History

Date	Revision	Description of Changes
January 2003	3	Third issue
June 2004	3	Changed the Style-sheet in compliance to the new "Corporate Technical Publications Design Guide"

Obsolete Product(s) - Obsolete Product(s)
Obsolete Product(s) - Obsolete Product(s)

Information furnished is believed to be accurate and reliable. However, STMicroelectronics assumes no responsibility for the consequences of use of such information nor for any infringement of patents or other rights of third parties which may result from its use. No license is granted by implication or otherwise under any patent or patent rights of STMicroelectronics. Specifications mentioned in this publication are subject to change without notice. This publication supersedes and replaces all information previously supplied. STMicroelectronics products are not authorized for use as critical components in life support devices or systems without express written approval of STMicroelectronics.

The ST logo is a registered trademark of STMicroelectronics.
All other names are the property of their respective owners

© 2004 STMicroelectronics - All rights reserved

STMicroelectronics GROUP OF COMPANIES

Australia - Belgium - Brazil - Canada - China - Czech Republic - Finland - France - Germany - Hong Kong - India - Israel - Italy - Japan -
Malaysia - Malta - Morocco - Singapore - Spain - Sweden - Switzerland - United Kingdom - United States

www.st.com