



Chipsmall Limited consists of a professional team with an average of over 10 year of expertise in the distribution of electronic components. Based in Hongkong, we have already established firm and mutual-benefit business relationships with customers from,Europe,America and south Asia,supplying obsolete and hard-to-find components to meet their specific needs.

With the principle of “Quality Parts,Customers Priority,Honest Operation,and Considerate Service”,our business mainly focus on the distribution of electronic components. Line cards we deal with include Microchip,ALPS,ROHM,Xilinx,Pulse,ON,Everlight and Freescale. Main products comprise IC,Modules,Potentiometer,IC Socket,Relay,Connector.Our parts cover such applications as commercial,industrial, and automotives areas.

We are looking forward to setting up business relationship with you and hope to provide you with the best service and solution. Let us make a better world for our industry!



Contact us

Tel: +86-755-8981 8866 Fax: +86-755-8427 6832

Email & Skype: info@chipsmall.com Web: www.chipsmall.com

Address: A1208, Overseas Decoration Building, #122 Zhenhua RD., Futian, Shenzhen, China





AUDIO MATRIX WITH SRS EFFECTS

SRS  The Device incorporates the SRS (Sound Retrieval System) under licence from SRS Labs, Inc. *everything else is only stereo™*

- 1 STEREO INPUT
- INPUT ATTENUATION CONTROL IN 0.5dB STEP
 - MUTE FUNCTION
- MONO MODE (SRS 3D MONO)
- STEREO MODE (SRS 3D STEREO)
- SPACE AND CENTER ATTENUATORS ARE AVAILABLE
- ALL FUNCTION ARE PROGRAMMABLE VIA SERIAL BUS (I²C BUS)

DESCRIPTION

The TDA7467 is a SRS (Sound Retrieval System) audio matrix. It reproduces SRS sound processing stereo and mono sources both.

The SRS sound is guaranteed by external compo-

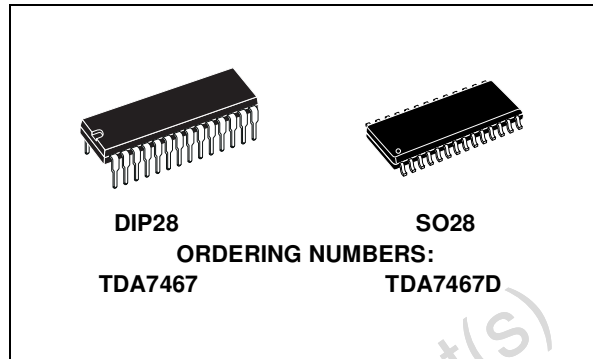

nents and it is not affected by internal process spreads.

The AC signal setting is obtained by resistor networks and switches combined with operational amplifiers according to the SRS labs specification.

Control of all the functions is accomplished by serial bus. Thanks to the used BIPOLAR/CMOS/DMOS technology, Low Distortion, Low Noise and DC stepping are obtained.

PIN CONNECTION (Top view)

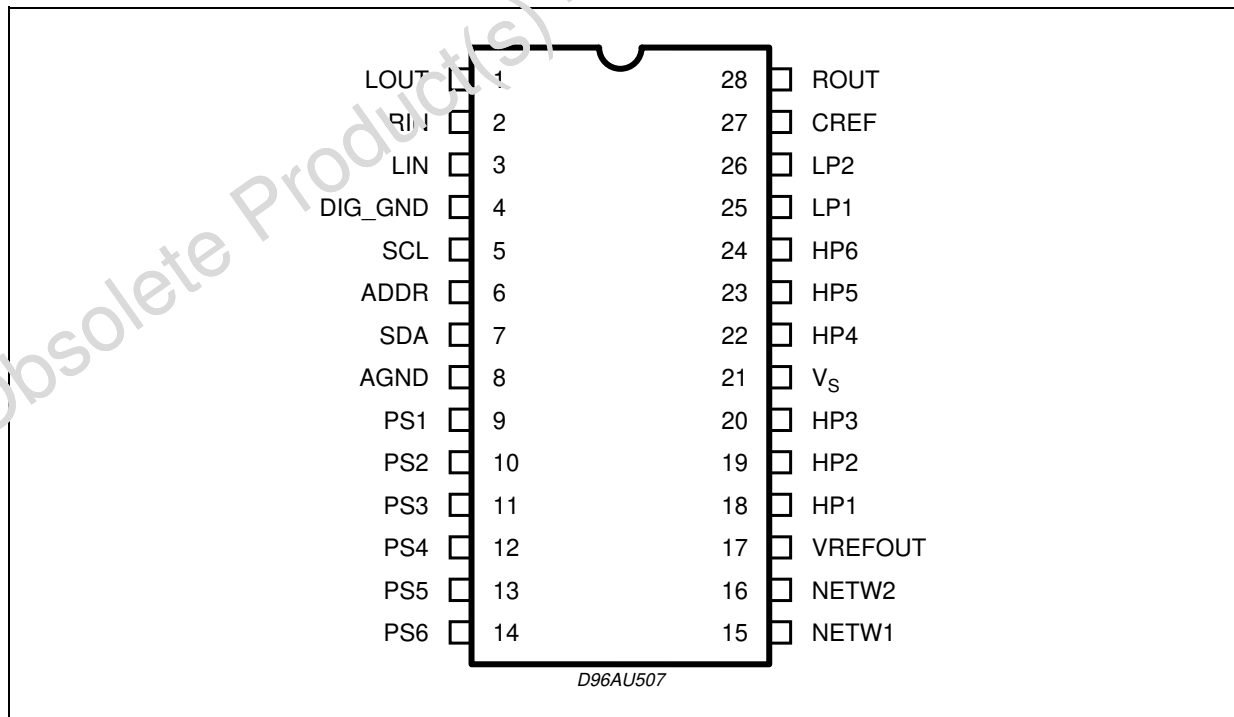

BLOCK DIAGRAM

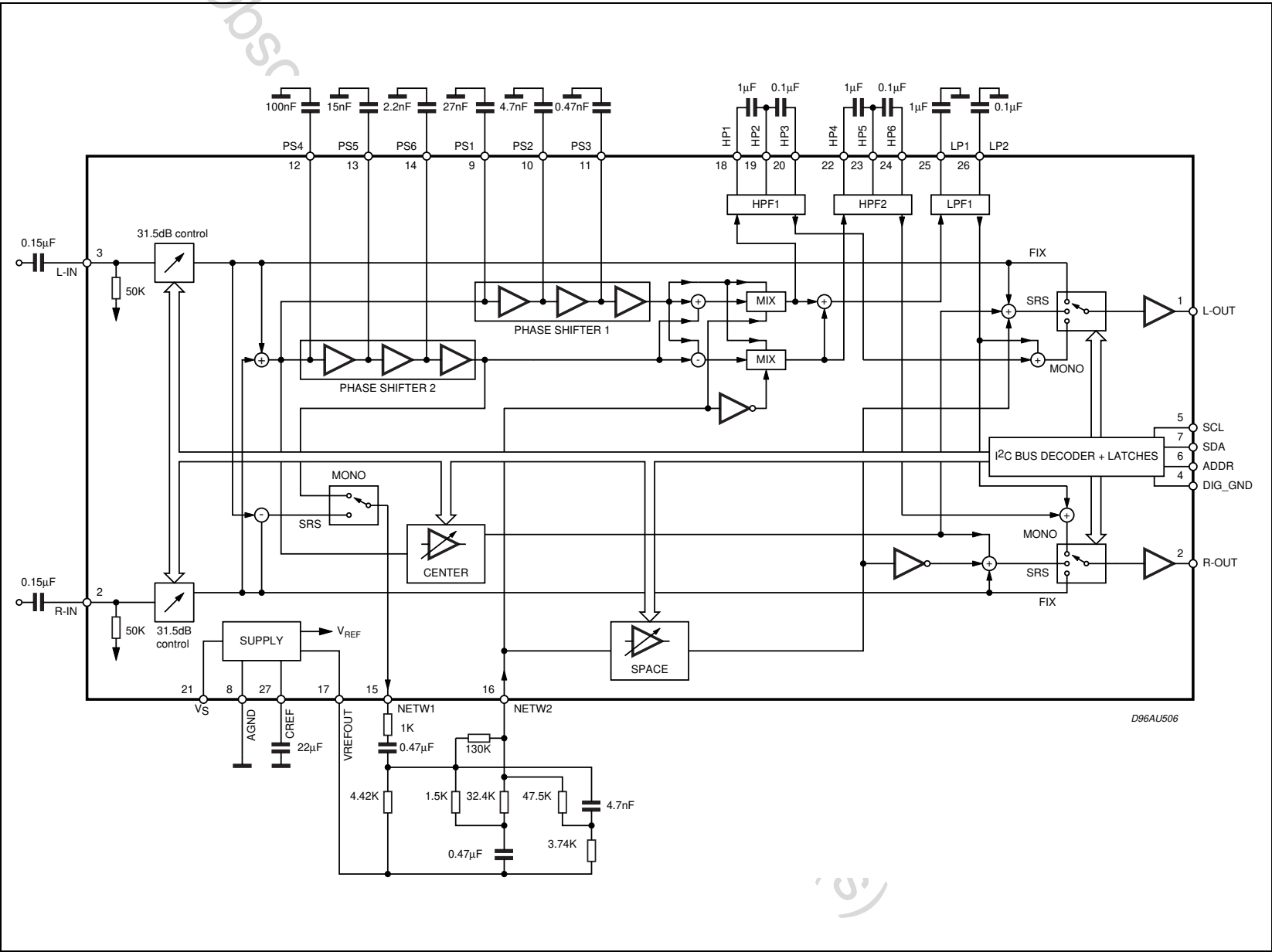

THERMAL DATA

Symbol	Parameter	Value	Unit
$R_{th\ j-pins}$	Thermal Resistance Junction-pins	Max. 85	°C/W

ABSOLUTE MAXIMUM RATINGS

Symbol	Parameter	Value	Unit
V_S	Operating Supply Voltage	11	V
T_{amb}	Operating Ambient Temperature	-10 to 85	°C
T_{stg}	Storage Temperature Range	-55 to +150	°C

QUICK REFERENCE DATA

Symbol	Parameter	Min.	Typ.	Max.	Unit
V_S	Supply Voltage	7	9	10.2	V
V_{CL}	Max. input signal handling	2			Vrms
THD	Total Harmonic Distortion $V = 1V_{rms}$ $f = 1KHz$	0.01	0.1	%	
S/N	Signal to Noise Ratio $V_{out} = 1V_{rms}$ (mode = OFF)		106		dB
S_C	Channel Separation $f = 1KHz$		90		dB
	Input Control (0.5dB)	-31.5		0	dB
	SRS Center Control (1dB step)	-31		0	dB
	SRS Space Control (1dB step)	-31		0	dB
	Mute Attenuation		100		dB

ELECTRICAL CHARACTERISTICS

Refer to the test circuit $T_{amb} = 25^{\circ}C$, $V_S = 9V$, $R_L = 10K\Omega$, $V_{in} = 1V_{rms}$; $R_G = 600\Omega$, all controls flat ($G = 0dB$), Effect Ctrl = -6dB, MODE = OFF; $f = 1KHz$ unless otherwise specified

Symbol	Parameter	Test Condition	Min.	Typ.	Max.	Unit
SUPPLY						
V_S	Supply Voltage		7	9	10.2	V
I_S	Supply Current			25		mA
SVR	Ripple Rejection	$L_{CH} / R_{CH\ out}$, Mode = OFF	60	80		dB
INPUT STAGE						
R_{IN}	Input Resistance		37.5	50	62.5	K Ω
V_{CL}	Clipping Level	THD = 0.3%	2	2.5		Vrms
A_{VMIN}	Min. Attenuation		-1	0	1	dB
A_{VMAX}	Max. Attenuation		31	31.5	32	dB
A_{STEP}	Step Resolution		-1	0.5	1	dB
V_{DC}	DC Steps	Adjacent att. step	-3	0	3	mV
SRS EFFECT CONTROL						
C_{range1}	Center/Space Control Range		-31		0	dB
S_{step1}	Center/Space Step Resolution			1		dB

ELECTRICAL CHARACTERISTICS (continued)

Refer to the test circuit $T_{amb} = 25^{\circ}\text{C}$, $V_S = 9\text{V}$, $R_L = 10\text{K}\Omega$, $V_{in} = 1\text{Vrms}$; $R_G = 600\Omega$, all controls flat ($G = 0\text{dB}$), Effect Ctrl = -6dB , MODE = OFF; $f = 1\text{KHz}$ unless otherwise specified

Symbol	Parameter	Test Condition	Min.	Typ.	Max.	Unit
AUDIO OUTPUTS						
$N_{o(\text{OFF})}$	Output Noise (OFF)	Output muted, Flat BW (20Hz to 20KHz)		4 5		μVrms μVrms
$N_{o(\text{srs})}$	Output noise (srs) Surround Sound	BW (20Hz to 20KHz)		50		μVrms
d	Distortion	$A_V = 0$; $V_{in} = 1\text{Vrms}$		0.01	0.1	%
S_C	Channel Separation			90		dB
V_{ocl}	Clipping Level	$d = 0.3\%$	2	2.5		Vrms
R_{out}	Output Resistance			30		Ω
V_{out}	DC Voltage Level			3.8		V
BUS INPUTS						
V_{il}	Input Low Voltage				1	V
V_{ih}	Input High Voltage		3			V
I_{in}	Input Current		-5		5	μA
V_o	Output Voltage SDA Acknowledge	$I_O = 1.6\text{mA}$			0.4	V

SRS SURROUND SOUND MATRIX

CENTER	SRS Control Range		-31		0	dB
Step _C	Center Step Resolution			1		dB
SPACE	SRS Space Control Range			-31	0	dB
Steps	Space Step Resolution			1		dB
P _{ERSP1}	Perspective 1	Input Signal of 125Hz SPACE = 0dB, CENTER = MUTE $R_{in} = \text{GND}$; $L_{in} \rightarrow R_{OUT}$		12		dB
P _{ERSP2}	Perspective 2	Input Signal of 2.15KHz SPACE = 0dB, CENTER = MUTE $R_{in} = \text{GND}$; $L_{in} \rightarrow R_{OUT}$		0		dB
L+R	L+ R SRS Curve	SPACE = 0dB, CENTER = MUTE $R_{in} = \text{GND}$; $L_{in} \rightarrow R_{OUT}$		-8.5		dB
L, R	L, R SRS Curve	SPACE = 0dB, CENTER = MUTE $R_{in} = \text{GND}$; $L_{in} \rightarrow L_{OUT}$ $L_{in} = \text{GND}$; $R_{in} \rightarrow R_{OUT}$		-13.4		dB

I²C BUS INTERFACE

Data transmission from microprocessor to the TDA7467 and vice versa takes place through the 2 wires I²C BUS interface, consisting of the two lines SDA and SCL (pull-up resistors to positive supply voltage must be connected).

Data Validity

As shown in fig. 1, the data on the SDA line must be stable during the high period of the clock. The HIGH and LOW state of the data line can only change when the clock signal on the SCL line is LOW.

Start and Stop Conditions

As shown in fig.2 a start condition is a HIGH to LOW transition of the SDA line while SCL is HIGH. The stop condition is a LOW to HIGH transition of the SDA line while SCL is HIGH.

Byte Format

Every byte transferred on the SDA line must contain 8 bits. Each byte must be followed by an acknowledge bit. The MSB is transferred first.

Acknowledge

The master (μ P) puts a restive HIGH level on the SDA line during the acknowledge clock pulse (see fig. 3). The peripheral (audio processor) that acknowledges has to pull-down (LOW) the SDA line during this clock pulse.

The audio processor which has been addressed has to generate an acknowledge after the reception of each byte, otherwise the SDA line remains at the HIGH level during the ninth clock pulse time. In this case the master transmitter can generate the STOP information in order to abort the transfer.

Transmission without Acknowledge

Avoiding to detect the acknowledge of the audio processor, the μ P can use a simpler transmission: simply it waits one clock without checking the slave acknowledging, and sends the new data.

This approach of course is less protected from misworking.

Figure 1. Data Validity on the I²CBUS

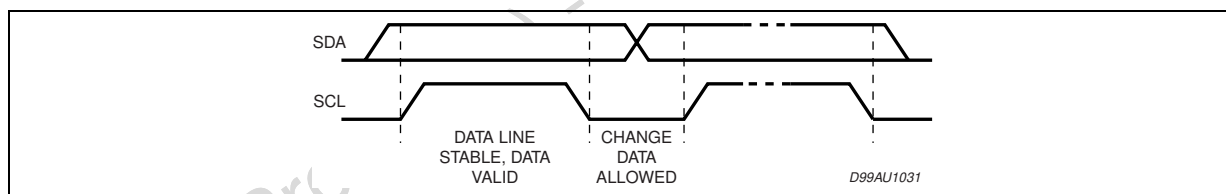

Figure 2. Timing Diagram of I²CBUS

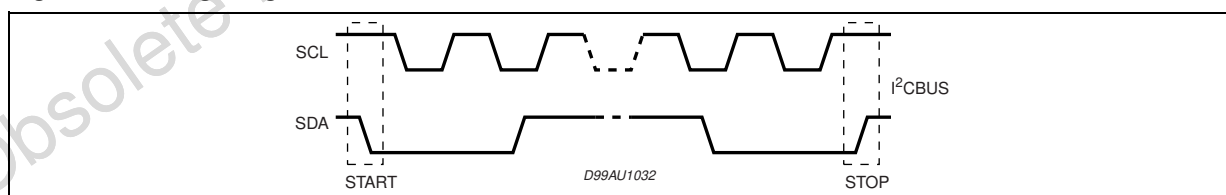
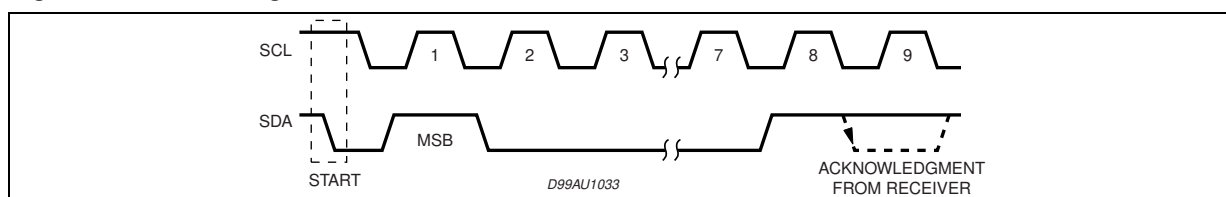

Figure 3. Acknowledge on the I²CBUS



SOFTWARE SPECIFICATION

Interface Protocol

The interface protocol comprises:

- A start condition (S)
- A chip address byte
- A subaddress bytes
- A sequence of data (N byte + acknowledge)
- A stop condition (P)

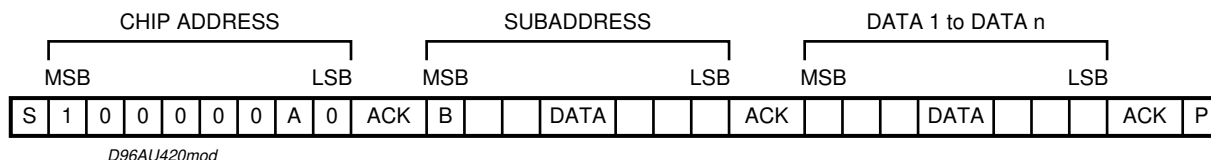

ACK = Acknowledge

S = Start; P = Stop

A = Address

B = Auto Increment

EXAMPLES

No Incremental Bus

The TDA7467 receives a start condition, the correct chip address, a subaddress with the MSB = 0 (no incremental bus), N-data (all these data concern the subaddress selected), a stop condition.

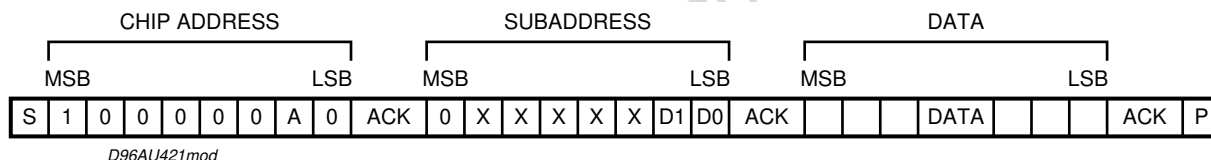

Incremental Bus

The TDA7467 receive a start conditions, the correct chip address, a subaddress with the MSB = 1 (incremental bus): now it is in a loop condition with an autoincrease of the subaddress whereas SUBADDRESS from "1XXXX1XX" to "1XXX111" of DATA are ignored.

The DATA 1 concern the subaddress sent, and the DATA 2 concerns the subaddress sent plus one sent in the loop etc, and at the end it receives the stop condition.

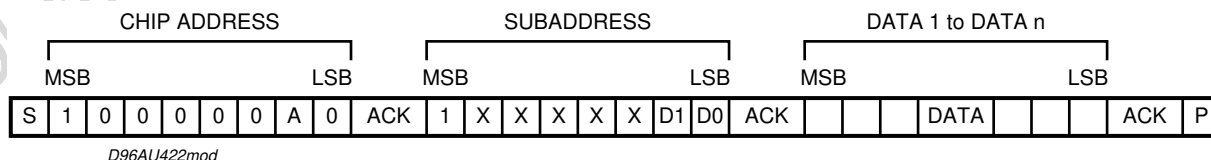

DATA BYTES (Address = 80(HEX) if ADDR pin is floating, 82(HEX) if ADDR pin is connected to VS):

FUNCTION SELECTION:

The first byte (subaddress)

MSB							LSB		SUBADDRESS
D7	D6	D5	D4	D3	D2	D1	D0		
B	X	X	X	X	X	0	0	MODE	
B	X	X	X	X	X	0	1	SRS/SPACE ATTENUATION	
B	X	X	X	X	X	1	0	SRS/CENTER ATTENUATION	
B	X	X	X	X	X	1	1	INPUT ATTENUATION	

B = 1: INCREMENTAL BUS; ACTIVE

B = 0: NO INCREMENTAL BUS

X = INDIFFERENT 0, 1

INPUT ATTENUATION SELECTION

MSB							LSB		INPUT ATTENUATION
D7	D6	D5	D4	D3	D2	D1	D0	0.5 dB STEPS	
					0	0	0	0	
					0	0	1	-0.5	
					0	1	0	-1	
					0	1	1	-1.5	
					1	0	0	-2	
					1	0	1	-2.5	
					1	1	0	-3	
					1	1	1	-3.5	
								4 dB STEPS	
	0	0	0	0				0	
	0	0	0	1				-4	
	0	0	1	0				-8	
	0	0	1	1				-12	
	0	1	0	0				-16	
	0	1	0	1				-20	
	0	1	1	0				-24	
	0	1	1	1				-28	
	1							MUTE	

INPUT ATTENUATION = 0 ~ -31.5dB

SRS MODE

D7	D6	D5	D4	D3	D2	D1	D0	MODE
						X	0	SRS OFF (FIX)
						X	1	SRS ON
						0	1	MONO SRS (MONO 3D)
						1	1	STEREO SRS (STEREO 3D)

RECOMMENDED TO ATTENUATE -3dB ON "SRS OFF"
ie. MONO SRS (MONO 3D): XXXXXX01

SPACE & CENTER ATTENUATION SELECTION

MSB							LSB	SPACE & CENTER ATT.
D7	D6	D5	D4	D3	D2	D1	D0	1 dB STEPS
					0	0	0	0
					0	0	1	-1
					0	1	0	-2
					0	1	1	-3
					1	0	0	-4
					1	0	1	-5
					1	1	0	-6
					1	1	1	-7
								8 dB STEPS
		0	0	0				0
		0	0	1				-8
		0	1	0				-16
		0	1	1				-24
		1	X	X	X	X	X	MUTE

X = INDIFFERENT 0, 1

SPACE & CENTER ATTENUATION = 0dB ~ -31dB

POWER ON RESET

INPUT	MUTE
MODE	OFF (FIX)
SPACE ATTENUATION	MUTE (MIN)
CENTER ATTENUATION	MUTR (MIN)

DIM.	mm			inch		
	MIN.	TYP.	MAX.	MIN.	TYP.	MAX.
a1		0.63			0.025	
b		0.45			0.018	
b1	0.23		0.31	0.009		0.012
b2		1.27			0.050	
D			37.34			1.470
E	15.2		16.68	0.598		0.657
e		2.54			0.100	
e3		33.02			1.300	
F			14.1			0.555
l		4.445			0.175	
L		3.3			0.130	

OUTLINE AND MECHANICAL DATA

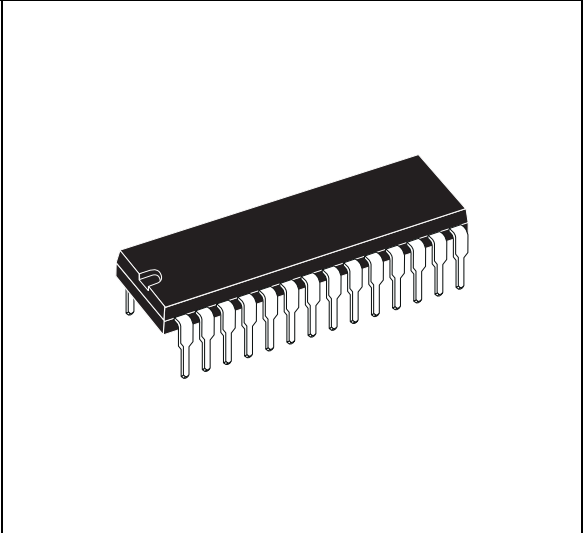

DIP28

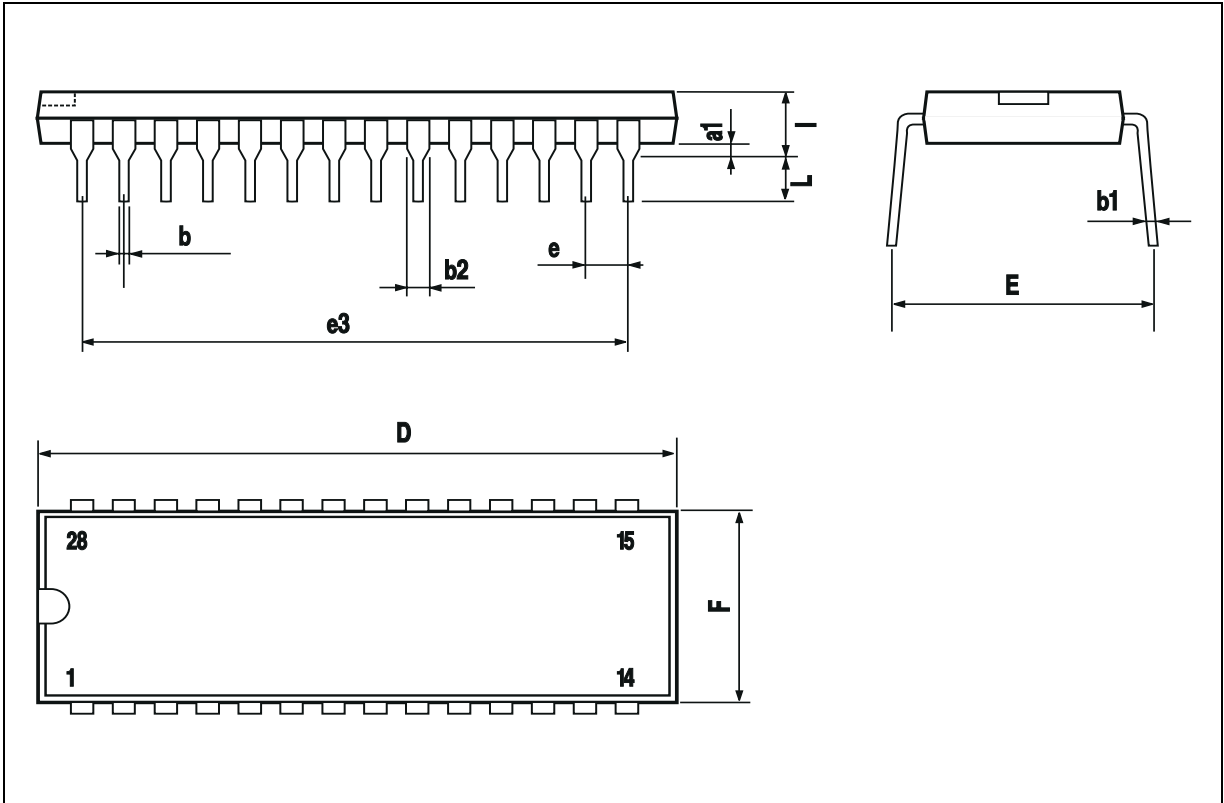

DIM.	mm			inch		
	MIN.	TYP.	MAX.	MIN.	TYP.	MAX.
A			2.65			0.104
a1	0.1		0.3	0.004		0.012
b	0.35		0.49	0.014		0.019
b1	0.23		0.32	0.009		0.013
C		0.5			0.020	
c1	45° (typ.)					
D	17.7		18.1	0.697		0.713
E	10		10.65	0.394		0.419
e		1.27			0.050	
e3		16.51			0.65	
F	7.4		7.6	0.291		0.299
L	0.4		1.27	0.016		0.050
S	8° (max.)					

OUTLINE AND MECHANICAL DATA

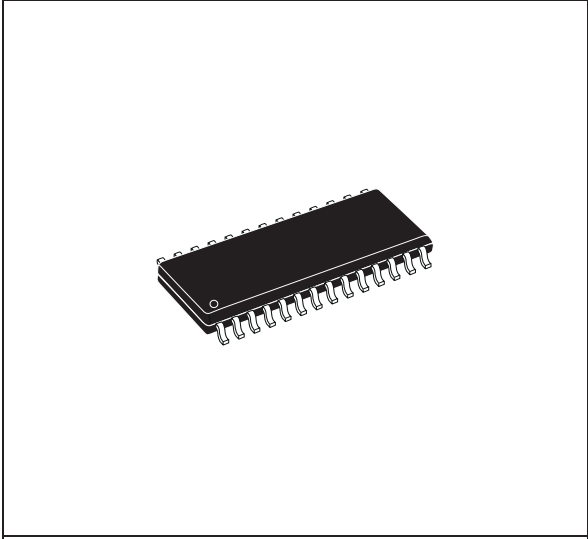

SO28

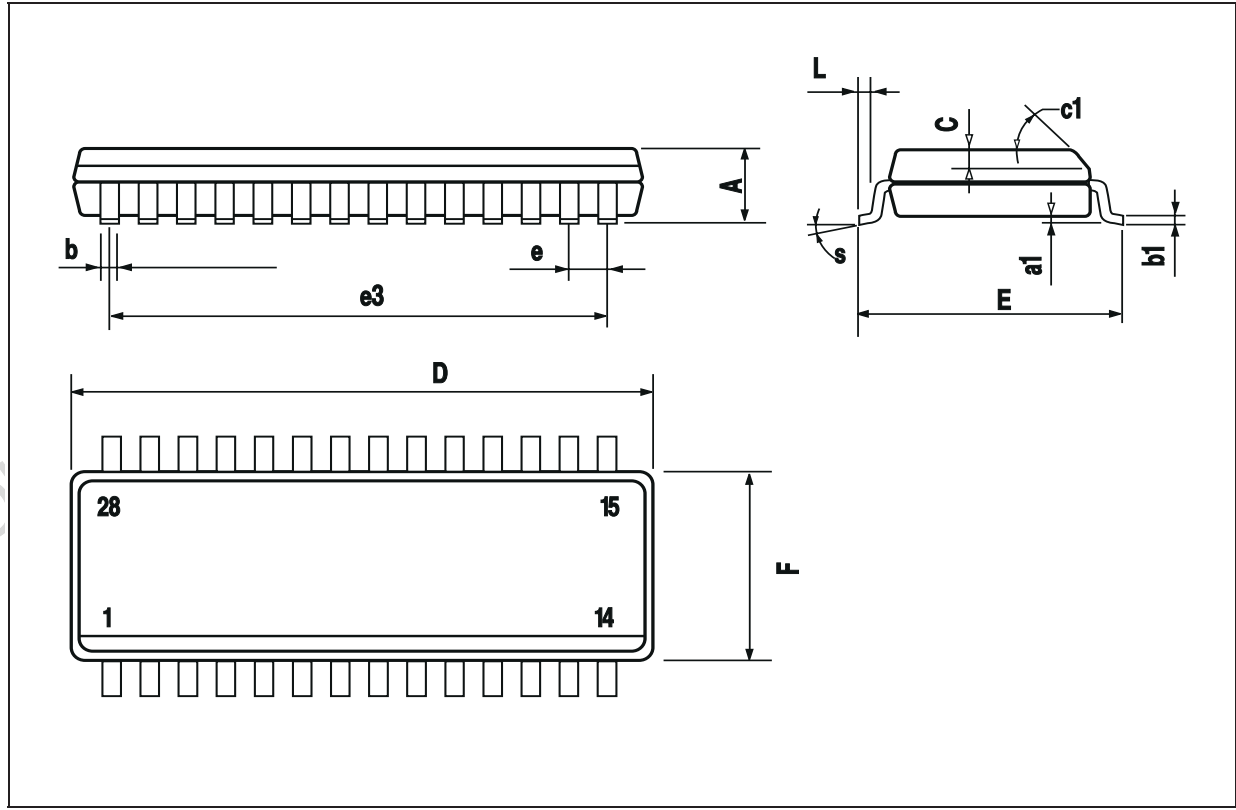

Information furnished is believed to be accurate and reliable. However, STMicroelectronics assumes no responsibility for the consequences of use of such information nor for any infringement of patents or other rights of third parties which may result from its use. No license is granted by implication or otherwise under any patent or patent rights of STMicroelectronics. Specifications mentioned in this publication are subject to change without notice. This publication supersedes and replaces all information previously supplied. STMicroelectronics products are not authorized for use as critical components in life support devices or systems without express written approval of STMicroelectronics.

The ST logo is a registered trademark of STMicroelectronics.
All other names are the property of their respective owners

© 2003 STMicroelectronics - All rights reserved

STMicroelectronics GROUP OF COMPANIES

Australia - Belgium - Brazil - Canada - China - Czech Republic - Finland - France - Germany - Hong Kong - India - Israel - Italy - Japan -
Malaysia - Malta - Morocco - Singapore - Spain - Sweden - Switzerland - United Kingdom - United States

www.st.com