



Chipsmall Limited consists of a professional team with an average of over 10 year of expertise in the distribution of electronic components. Based in Hongkong, we have already established firm and mutual-benefit business relationships with customers from,Europe,America and south Asia,supplying obsolete and hard-to-find components to meet their specific needs.

With the principle of “Quality Parts,Customers Priority,Honest Operation,and Considerate Service”,our business mainly focus on the distribution of electronic components. Line cards we deal with include Microchip,ALPS,ROHM,Xilinx,Pulse,ON,Everlight and Freescale. Main products comprise IC,Modules,Potentiometer,IC Socket,Relay,Connector.Our parts cover such applications as commercial,industrial, and automotives areas.

We are looking forward to setting up business relationship with you and hope to provide you with the best service and solution. Let us make a better world for our industry!



Contact us

Tel: +86-755-8981 8866 Fax: +86-755-8427 6832

Email & Skype: info@chipsmall.com Web: www.chipsmall.com

Address: A1208, Overseas Decoration Building, #122 Zhenhua RD., Futian, Shenzhen, China



TWO BANDS DIGITALLY CONTROLLED AUDIO PROCESSOR WITH BASS ALC SURROUND

1 FEATURES

- INPUT MULTIPLEXER
 - 4 STEREO INPUTS
 - SELECTABLE INPUT GAIN FOR OPTIMAL ADAPTATION TO DIFFERENT SOURCES
- ONE STEREO OUTPUT
- BASS ALC
- TREBLE AND BASS CONTROL IN 2.0dB
- STEPS
- VOLUME CONTROL IN 1.0dB STEPS
- TWO SPEAKER ATTENUATORS:
 - TWO INDEPENDENT SPEAKER CONTROL IN 1.0dB STEPS FOR BALANCE FACILITY
 - INDEPENDENT MUTE FUNCTION
- ALL FUNCTION ARE PROGRAMMABLE VIA
- SERIAL BUS
- EXTERNALLY ADJUSTABLE SURROUND

Figure 1. Package



Table 1. Order Codes

Part Number	Package
TDA7468D	SO28
TDA7468D13TR	Tape & Reel

applications in Hi-Fi systems.

Selectable input gain is provided. Control of all the functions is accomplished by serial bus.

The AC signal setting is obtained by resistor networks and switches combined with operational amplifiers.

Thanks to the used BIPOLAR/CMOS Technology, Low Distortion, Low Noise and DC stepping are obtained

2 DESCRIPTION

The TDA7468D is a volume tone (bass and treble) balance (Left/Right) processor for quality audio

Figure 2. PIN CONNECTION (Top view)

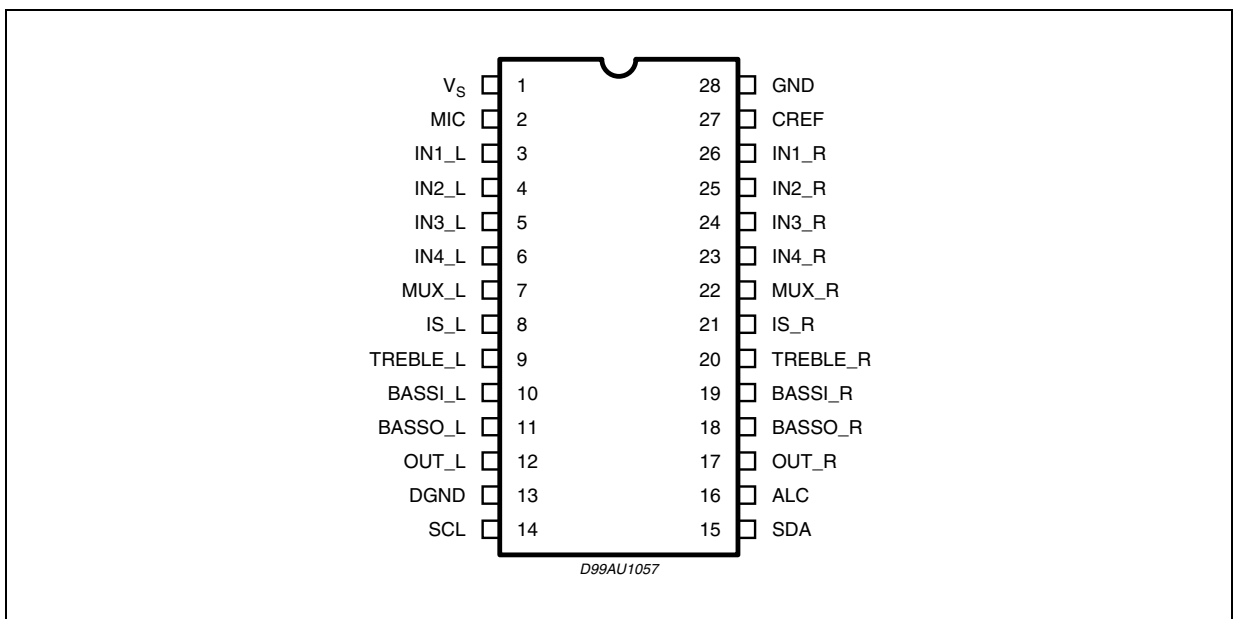

Figure 3. BLOCK DIAGRAM

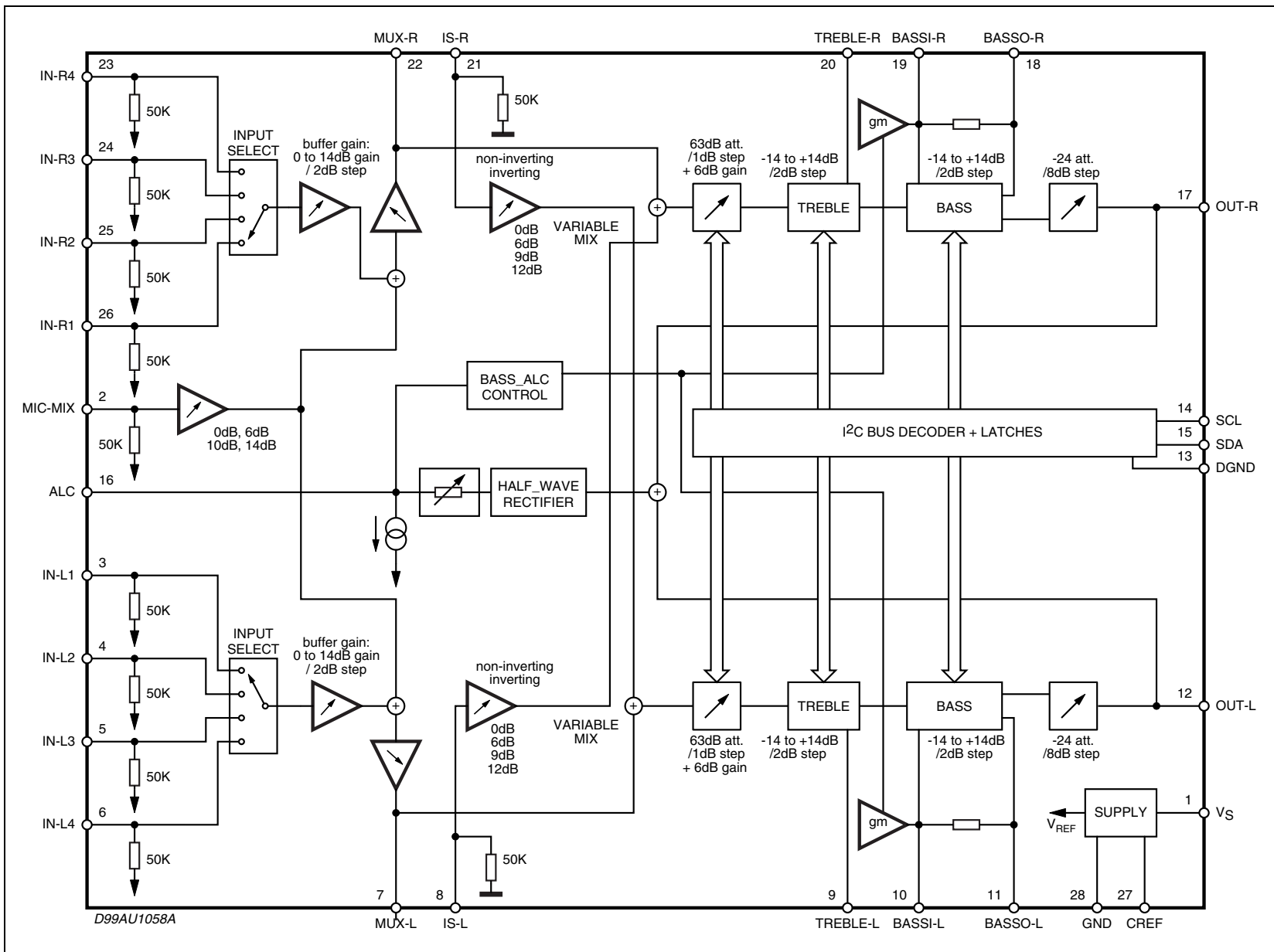

Table 2. ABSOLUTE MAXIMUM RATINGS

Symbol	Parameter	Value	Unit
V_S	Operating Supply Voltage	10.5	V
T_{amb}	Operating Ambient Temperature	0 to 70	°C
T_{stg}	Storage Temperature Range	-55 to 150	°C

Table 3. THERMAL DATA

Symbol	Parameter	Value	Unit
$R_{th\ j-pin}$	Thermal Resistance Junction-pins	85	°C/W

Table 4. QUICK REFERENCE DATA

Symbol	Parameter	Min.	Typ.	Max.	Unit
V_S	Supply Voltage	5	9	10	V
V_{CL}	Max. input signal handling	2			V _{rms}
THD	Total Harmonic Distortion $V_I = 1V_{rms}$; $f = 1KHz$		0.01	%	%
	Total Harmonic Distortion $V_I = 0.1V_{rms}$; $f = 1KHz$			0.1	%
S/N	Signal to Noise Ratio $V_{out} = 1V_{rms}$ (0dB)		100		dB
S_C	Channel Separation $f = 1KHz$		90		dB
	Input Gain (2dB step)	0		14	dB
	Volume Control (1dB step)	-87		0	dB
	Treble Control (2dB step)	-14		+14	dB
	Bass Control (2dB step)	-14		+14	dB
	Mute Attenuation		86		dB

ELECTRICAL CHARACTERISTICS

(refer to the test circuit $T_{amb} = 25^{\circ}\text{C}$, $V_S = 9\text{V}$, $f = 1\text{KHz}$ all controls flat ($G = 0\text{dB}$), unless otherwise specified)

Symbol	Parameter	Test Condition	Min.	Typ.	Max.	Unit
SUPPLY						
V_S	Supply Voltage		5	9	10	V
I_S	Supply Current			9		mA
SVR	Ripple Rejection		60	90		dB
INPUT STAGE						
R_{IN}	Input Resistance		35	50	65	K Ω
V_{CL}	Clipping Level	THD = 0.3%	2	2.5		V_{rms}
S_{IN}	Input Separation		80	100		dB
G_{inmin}	Minimum Input Gain		-1	0	1	dB
G_{inmax}	Maximum Input Gain			14		dB
G_{step}	Step Resolution			2		dB
MIC						
R_{IN}	Input Resistance		35	50	65	K Ω
G_{mic1}	Mic Input Gain 1			14		dB
G_{mic2}	Mic Input Gain 2			10		dB
G_{mic3}	Mic Input Gain 3			6		dB
G_{min4}	Mic Input Gain 4			0		dB
MIX_{mic}	Mixing Rate			50		%
SURROUND						
R_{in}	Input Resistance		35	50	65	K Ω
G_{inmin}	Minimum Input Gain		-1	0	1	dB
G_{inmax}	Maximum Input Gain			12		dB
G_{inV}	Inverting Gain			-1		
M_{ixmin}	Minimum Mixing Rate			0		%
M_{ixmax}	Maximum Mixing Rate			100		%
Crosstalk k	Crosstalk of Mux Output to 100% IS		40			dB
G_{buffer}	Buffer Gain			6		dB
VOLUME CONTROL						
CRANGE1	Vol 1 Control Range			63		dB
AVMAX1	Vol 1 Max. Attenuation		61	63	65	dB
ASTEP1	Vol 1 Step Resolution		0.5	1	1.5	dB
Match1	Matching			TBD		dB
CRANGE2	Vol 2 Control Range			24		dB
AVMAX2	Vol 2 Max. Attenuation		22	24	26	dB
ASTEP2	Vol 2 Step Resolution		7	8	9	dB
Match2	Matching			TBD		dB
AVMAX1+ AVMAX2	Vol 1 + Vol 2 Max Attenuation			84		dB

ELECTRICAL CHARACTERISTICS (continua)

(refer to the test circuit $T_{amb} = 25^{\circ}\text{C}$, $V_S = 9\text{V}$, $f = 1\text{KHz}$ all controls flat ($G = 0\text{dB}$), unless otherwise specified)

Symbol	Parameter	Test Condition	Min.	Typ.	Max.	Unit
BASS CONTROL						
G _b	Control Range	Max. Boost/cut	±12.0	±14.0	±16.0	dB
B _{STEP}	Step Resolution		1	2	3	dB
R _B	Internal Feedback Resistance		33	44	55	KΩ
BASS ALC CONTROL						
R _{attack1}	Attack Time Resistor 1			12.5		KΩ
R _{attack2}	Attack Time Resistor 2			25		KΩ
R _{attack3}	Attack Time Resistor 3			50		KΩ
R _{attack4}	Attack Time Resistor 4			100		KΩ
Thresh1	Threshold 1			700		mV _{rms}
Thresh2	Threshold 2			485		mV _{rms}
Thresh3	Threshold 3			320		mV _{rms}
Thresh4	Threshold 4			170		mV _{rms}
TREBLE CONTROL						
G _t	Control Range	Max. Boost/cut	+13.0	+14.0	+15.0	dB
T _{STEP}	Step Resolution		1	2	3	dB
R _t	Internal Resistance			25		KΩ
AUDIO OUTPUTS						
V _{OCL}	Clipping Level	THD = 0.3%	2	2.5		V _{rms}
R _L	Output Load Resistance		2			KΩ
V _{O_{UT}}	DC Voltage Level			4.5		V
GENERAL						
E _{NO}	Output Noise	BW = 20Hz to 20KHz;				
		All gains 0dB;				
		output muted		5		μV
		flat		10	15	μV
S/N	Signal to Noise Ratio	All gains 0dB; V _O = 1V _{rms} ;		100		dB
S _C	Channel Separation Left/Right			90		dB
d	Distortion	A _V = 0; V _I = 0.1V _{rms} ;			0.1	%
		A _V = 0; V _I = 1V _{rms} ;		0.01		%
S _C	Channel Separation left/right			90		dB
	Total Tracking Error			0	1	dB
BUS INPUT						
V _{IL}	Input Low Voltage				1	V
V _{IH}	Input High Voltage		2.5			V
I _{IN}	Input Current	V _{IN} = 0.4V	-5		5	μA
V _O	Output Voltage (ACK)	I _O = 1.6mA		0.4	0.8	V

Figure 4. TEST CIRCUIT

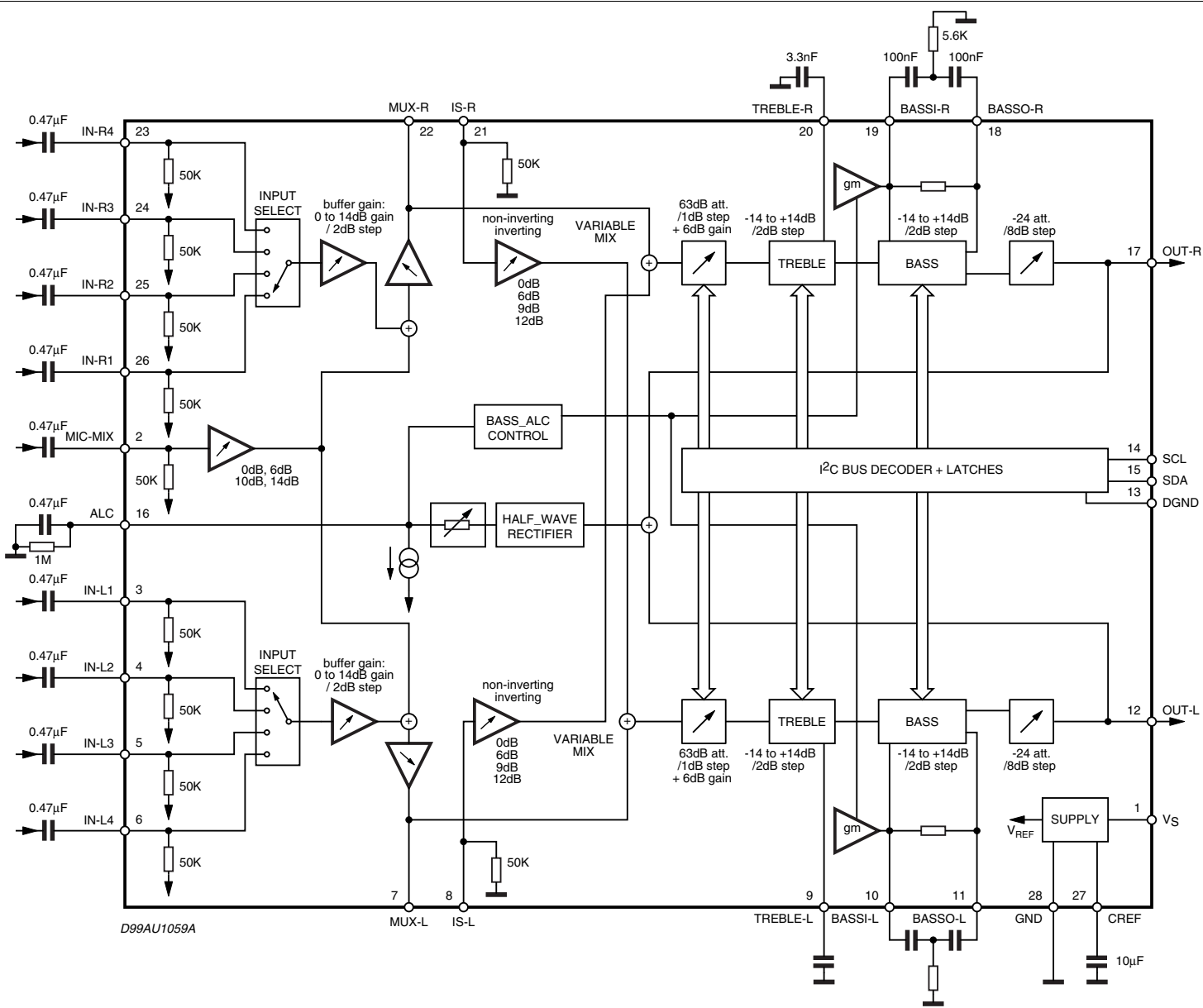

3 APPLICATION SUGGESTIONS

The first and the last stages are volume control blocks. The control range is 0 to -63dB (mute) with 1dB step resolution for this first one, 0 to 24dB (mute) with 8dB step resolution for the last one.

The very high resolution allows the implementation of systems free from any noisy acoustical effect.

The TDA7468D audioprocessor provides 2 bands tones control.

3.1 Bass, Stages

The Bass cell has an internal resistor $R_i = 44K\Omega$ typical.

Several filter types can be implemented, connecting external components to the Bass IN and OUT pins.

The fig.5 refers to basic **T Type Bandpass Filter** starting from the filter component values (R_1 internal and R_2, C_1, C_2 external) the centre frequency F_C , the gain A_V at max. boost and the filter Q factor are computed as follows:

$$F_C = \frac{1}{2 \cdot \pi \cdot \sqrt{R_1 \cdot R_2 \cdot C_1 \cdot C_2}}$$

$$A_V = \frac{R_2 C_2 + R_2 C_1 + R_i C_1}{R_2 C_1 + R_2 C_2}$$

$$Q = \frac{\sqrt{R_1 \cdot R_2 \cdot C_1 \cdot C_2}}{R_2 C_1 + R_2 C_2}$$

Viceversa, once F_C , A_V , and R_i internal value are fixed, the external components values will be:

$$C_1 = \frac{A_V - 1}{2 \cdot \pi \cdot F_C \cdot R_i \cdot Q} \quad C_2 = \frac{Q^2 \cdot C_1}{A_V - 1 - Q^2}$$

$$R_2 = \frac{A_V - 1 - Q^2}{2 \cdot \pi \cdot C_1 \cdot F_C \cdot (A_V - 1) \cdot Q}$$

3.2 Treble Stage

The treble stage is a high pass filter whose time constant is fixed by an internal resistor (25K Ω typical) and an external capacitor connected between treble pins and ground.

3.3 CREF

The suggested 10 μ F reference capacitor (CREF) value can be reduced to 4.7 μ F if the application requires faster power ON.

Figure 5.

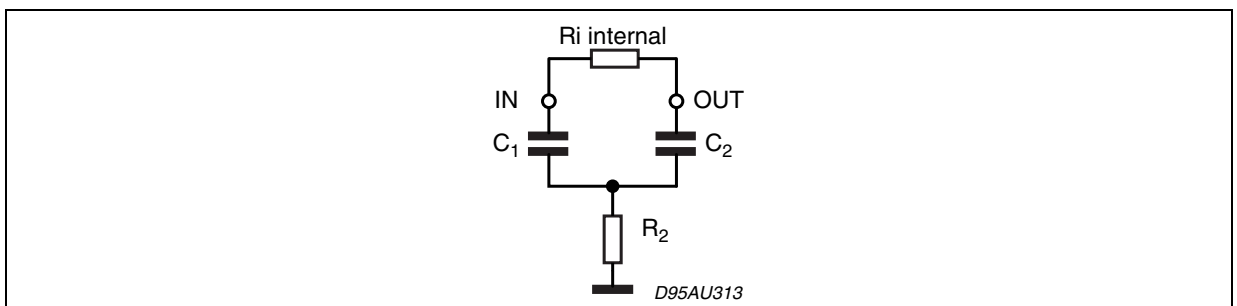

4 I²C BUS INTERFACE

Data transmission from microprocessor to the TDA7468D and vice versa takes place through the 2 wires I²C BUS interface, consisting of the two lines SDA and SCL (pull-up resistors to positive supply voltage must be connected).

4.1 Data Validity

As shown in fig. 6, the data on the SDA line must be stable during the high period of the clock. The HIGH and LOW state of the data line can only change when the clock signal on the SCL line is LOW.

4.2 Start and Stop Conditions

As shown in fig.7 a start condition is a HIGH to LOW transition of the SDA line while SCL is HIGH. The stop condition is a LOW to HIGH transition of the SDA line while SCL is HIGH.

4.3 Byte Format

Every byte transferred on the SDA line must contain 8 bits. Each byte must be followed by an acknowledge bit. The MSB is transferred first.

4.4 Acknowledge

The master (μ P) puts a restive HIGH level on the SDA line during the acknowledge clock pulse (see fig. 4). The peripheral (audio processor) that acknowledges has to pull-down (LOW) the SDA line during this clock pulse. The audio processor which has been addressed has to generate an acknowledge after the reception of each byte, otherwise the SDA line remains at the HIGH level during the ninth clock pulse time. In this case the master transmitter can generate the STOP information in order to abort the transfer.

4.5 Transmission without Acknowledge

Avoiding to detect the acknowledge of the audio processor, the μ P can use a simpler transmission: simply it waits one clock without checking the slave acknowledging, and sends the new data. This approach of course is less protected from misworking.

Figure 6. Data Validity on the I²CBUS

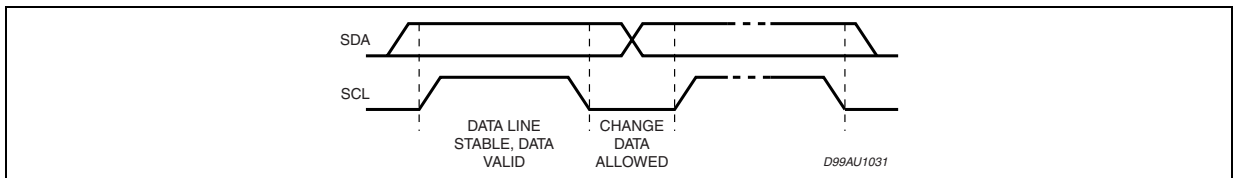

Figure 7. Timing Diagram of I²CBUS

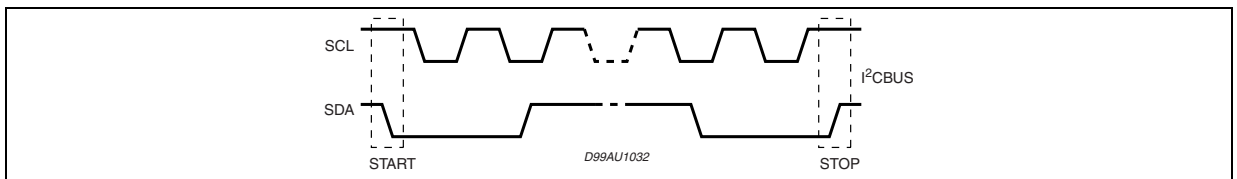
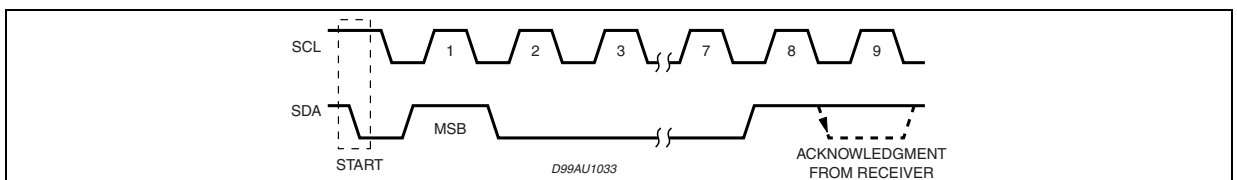

Figure 8. Acknowledge on the I²CBUS



5 SOFTWARE SPECIFICATION

Interface Protocol

The interface protocol comprises:

- A start condition (S)
- A chip address byte, containing the TDA7468D address
- A subaddress bytes
- A sequence of data (N byte + acknowledge)
- A stop condition (P)

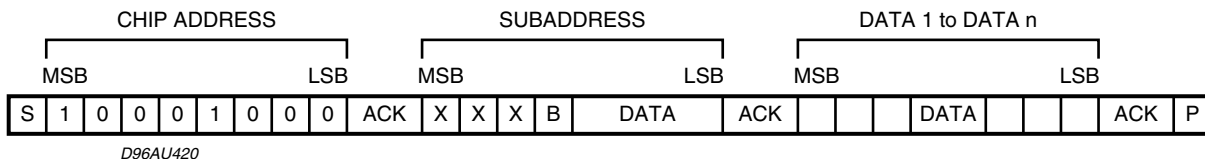

ACK = Acknowledge

S = Start; P = Stop

A = Address

B = Auto Increment

6 EXAMPLES

6.1 No Incremental Bus

The TDA7468D receives a start condition, the correct chip address, a subaddress with the B = 0 (no incremental bus), N-data (all these data concern the subaddress selected), a stop condition.

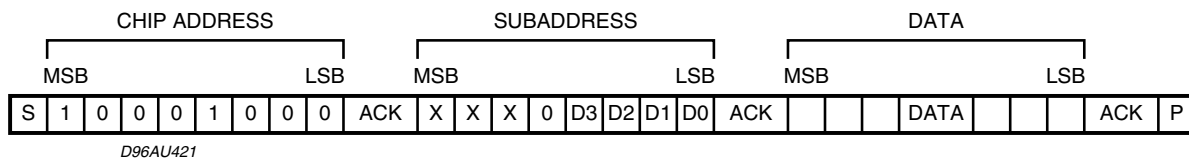

6.2 Incremental Bus

The TDA7468D receive a start conditions, the correct chip address, a subaddress with the B = 1 (incremental bus): now it is in a loop condition with an autoincrease of the subaddress whereas SUBADDRESS from "XXX1000" to "XXX1111" of DATA are ignored.

The DATA 1 concern the subaddress sent, and the DATA 2 concern the subaddress sent plus one in the loop etc, and at the end it receives the stop condition.

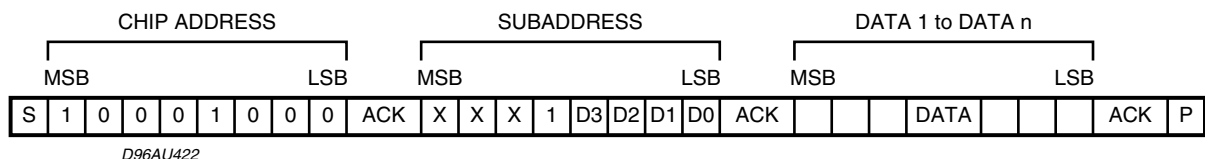

Table 5. POWER ON RESET CONDITION

MSB							LSB
D7	D6	D5	D4	D3	D2	D1	D0
1	1	1	1	1	1	1	0

7 DATA BYTES

Address = (HEX) 10001000.

Table 6. FUNCTION SELECTION: First byte (subaddress)

MSB							LSB	SUBADDRESS
D7	D6	D5	D4	D3	D2	D1	D0	
X	X	X	B	0	0	0	0	INPUT SELECT & MIC
X	X	X	B	0	0	0	1	INPUT GAIN
X	X	X	B	0	0	1	0	SURROUND
X	X	X	B	0	0	1	1	VOLUME LEFT
X	X	X	B	0	1	0	0	VOLUME RIGHT
X	X	X	B	0	1	0	1	TREBLE & BASS
X	X	X	B	0	1	1	0	OUTPUT
X	X	X	B	0	1	1	1	BASS ALC

B = 1: INCREMENTAL BUS; ACTIVE

B = 0: NO INCREMENTAL BUS

X = INDIFFERENT 0/1

Table 7. INPUT SELECTION & MIC

MSB							LSB	INPUT SELECT
D7	D6	D5	D4	D3	D2	D1	D0	
					0	0	0	IN1
					0	0	1	IN2
					0	1	0	IN3
					0	1	1	IN4
								MUTE (IN5)
					1			ON (IN5)
					0			OFF
								MIC
			0	0				Gain: 14dB
			0	1				Gain: 10dB
			1	0				Gain: 6dB
			1	1				Gain: 0dB
		1						OFF
		0						ON

Table 8. INPUT GAIN SELECTION

MSB							LSB	INPUT GAIN
D7	D6	D5	D4	D3	D2	D1	D0	2dB STEPS
					0	0	0	0dB
					0	0	1	2dB
					0	1	0	4dB
					0	1	1	6dB
					1	0	0	8dB
					1	0	1	10dB
					1	1	0	12dB
					1	1	1	14dB

GAIN = 0 to 30dB

Table 9. SURROUND

MSB							LSB	SURROUND
D7	D6	D5	D4	D3	D2	D1	D0	
								SURROUND MODE
							1	ON
							0	OFF
								GAIN
					0	0		0dB
					0	1		6dB
					1	0		9dB
					1	1		12dB
								MIXING
		0	0	0				inverting : 100%
		0	0	1				inverting : 50%
		0	1	0				inverting : 25%
		0	1	1				0%
		1	0	0				non-inverting : 100%
		1	0	1				non-inverting : 75%
		1	1	0				non-inverting : 50%
		1	1	1				mute
								BUFFER GAIN
	1							0
	0							6dB

Table 10. VOLUME

MSB							LSB	VOLUME
D7	D6	D5	D4	D3	D2	D1	D0	1dB STEPS
					0	0	0	0dB
					0	0	1	-1dB
					0	1	0	-2dB
					0	1	1	-3dB
					1	0	0	-4dB
					1	0	1	-5dB
					1	1	0	-6dB
					1	1	1	-7dB
								8dB STEPS
		0	0	0				0dB
		0	0	1				-8dB
		0	1	0				-16dB
		0	1	1				-24dB
		1	0	0				-32dB
		1	0	1				-40dB
		1	1	0				-48dB
		1	1	1				-56dB
								VOLUME 2
0	0							0dB
0	1							-8dB
1	0							-16dB
1	1							-24dB

VOLUME = 0 to -87dB

Table 11. VOLUME setting 1

Target Volume (dB)	Volume1 1dB step (dB)	Volume1 8dB step (dB)	Volume2 8dB step (dB)
0	0	0	0
-1	-1		
-2	-2		
-3	-3		
-4	-4		
-5	-5		
-6	-6		
-7	-7	-8	0
-8	0		
-9	-1		
-10	-2		
-11	-3		
-12	-4		
-13	-5		
-14	-6		
-15	-7		

Table 11. VOLUME setting 1 (continua)

Target Volume (dB)	Volume1 1dB step (dB)	Volume1 8dB step (dB)	Volume2 8dB step (dB)
-16	0	-16	0
-17	-1		
-18	-2		
-19	-3		
-20	-4		
-21	-5		
-22	-6		
-23	-7		
-24	0	-24	0
-25	-1		
-26	-2		
-27	-3		
-28	-4		
-29	-5		
-30	-6		
-31	-7		
-32	0	-32	0
-33	-1		
-34	-2		
-35	-3		
-36	-4		
-37	-5		
-38	-6		
-39	-7		
-40	0	-40	0
-41	-1		
-42	-2		
-43	-3		
-44	-4		
-45	-5		
-46	-6		
-47	-7		
-48	0	-48	0
-49	-1		
-50	-2		
-51	-3		
-52	-4		
-53	-5		
-54	-6		
-55	-7		
Target Volume (dB)	Volume1 1dB step (dB)	Volume1 8dB step (dB)	Volume2 8dB step (dB)
-56	0	-56	0
-57	-1		

Table 11. VOLUME setting 1 (continua)

-58	-2		
-59	-3		
-60	-4		
-61	-5		
-62	-6		
-63	-7		
-64	0	-56	8
-65	-1		
-66	-2		
-67	-3		
-68	-4		
-69	-5		
-70	-6		
-71	-7		
-72	0	-56	-16
-73	-1		
-74	-2		
-75	-3		
-76	-4		
-77	-5		
-78	-6		
-79	-7		
-80	0	-56	-24
-81	-1		
-82	-2		
-83	-3		
-84	-4		
-85	-5		
-86	-6		
-87	-7		

Table 12. VOLUME setting 2

Target Volume (dB)	Volume1 1dB step (dB)	Volume1 8dB step (dB)	Volume2 8dB step (dB)
0	0	0	0
-1	-1		
-2	-2		
-3	-3		
-4	-4		
-5	-5		
-6	-6		
-7	-7		

Table 12. VOLUME setting 2 (continua)

Target Volume (dB)	Volume1 1dB step (dB)	Volume1 8dB step (dB)	Volume2 8dB step (dB)
-8	0	-8	0
-9	-1		
-10	-2		
-11	-3		
-12	-4		
-13	-5		
-14	-6		
-15	-7		
-16	0	-16	0
-17	-1		
-18	-2		
-19	-3		
-20	-4		
-21	-5		
-22	-6		
-23	-7		
-24	0	-16	-8
-25	-1		
-26	-2		
-27	-3		
-28	-4		
-29	-5		
-30	-6		
-31	-7		
-32	0	-16	-16
-33	-1		
-34	-2		
-35	-3		
-36	-4		
-37	-5		
-38	-6		
-39	-7		
-40	0	-16	-24
-41	-1		
-42	-2		
-43	-3		
-44	-4		
-45	-5		
-46	-6		
-47	-7		

Table 12. VOLUME setting 2 (continua)

Target Volume (dB)	Volume1 1dB step (dB)	Volume1 8dB step (dB)	Volume2 8dB step (dB)
-48	0	-24	-24
-49	-1		
-50	-2		
-51	-3		
-52	-4		
-53	-5		
-54	-6		
-55	-7		
-56	0	-32	-24
-57	-1		
-58	-2		
-59	-3		
-60	-4		
-61	-5		
-62	-6		
-63	-7		
-64	0	-40	-24
-65	-1		
-66	-2		
-67	-3		
-68	-4		
-69	-5		
-70	-6		
-71	-7		
-72	0	-48	-24
-73	-1		
-74	-2		
-75	-3		
-76	-4		
-77	-5		
-78	-6		
-79	-7		
-80	0	-56	-24
-81	-1		
-82	-2		
-83	-3		
-84	-4		
-85	-5		
-86	-6		
-87	-7		

Table 13. TREBLE & BASS SELECTION

MSB							LSB	
D7	D6	D5	D4	D3	D2	D1	D0	TREBLE
				0	0	0	0	-14dB
				0	0	0	1	-12dB
				0	0	1	0	-10dB
				0	0	1	1	-8dB
				0	1	0	0	-6dB
				0	1	0	1	-4dB
				0	1	1	0	-2dB
				0	1	1	1	0dB
				1	0	0	0	14dB
				1	0	0	1	12dB
				1	0	1	0	10dB
				1	0	1	1	8dB
				1	1	0	0	6dB
				1	1	0	1	4dB
				1	1	1	0	2dB
				1	1	1	1	0dB
								BASS (*)
0	0	0	0					-14dB
0	0	0	1					-12dB
0	0	1	0					-10dB
0	0	1	1					-8dB
0	1	0	0					-6dB
0	1	0	1					-4dB
0	1	1	0					-2dB
0	1	1	1					0dB
1	0	0	0					14dB
1	0	0	1					12dB
1	0	1	0					10dB
1	0	1	1					8dB
1	1	0	0					6dB
1	1	0	1					4dB
1	1	1	0					2dB
1	1	1	1					0dB

(*) When BASS is programmed in the range -14dB/0dB, ALC is automatically switched to "OFF".

Table 14. OUTPUT

MSB							LSB	
D7	D6	D5	D4	D3	D2	D1	D0	MUTE
							0	ON
							1	OFF

Table 15. BASS ALC

MSB							LSB		BASS ALC
D7	D6	D5	D4	D3	D2	D1	D0		
								ALC Mode	
							1	ON	
							0	OFF	
								Detector	
						1		ON	
						0		OFF	
								Release Current Circuit	
					1			ON	
					0			OFF	
								Attack Time Resistor	
			0	0				12.5KΩ	
			0	1				25KΩ	
			1	0				50KΩ	
			1	1				100KΩ	
								Threshold	
	0	0						700mVrms	
	0	1						485mVrms	
	1	0						320mVrms	
	1	1						170mVrms	
								Attack Mode	
0								MODE 1: Fixed Resistor	
1								MODE 2: Adaptive	

Figure 9. BASS ALC : Threshold curve

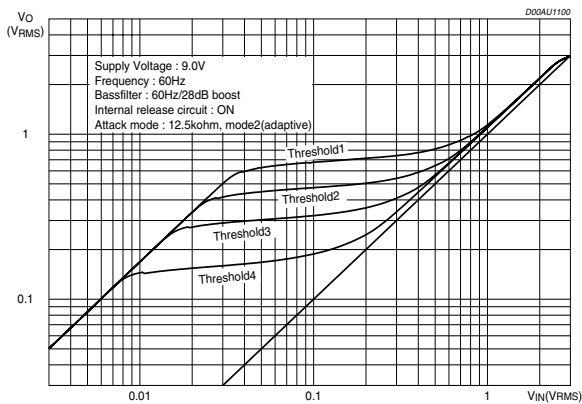
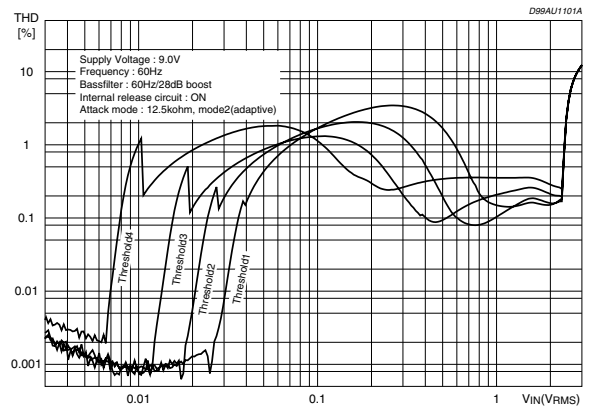

Figure 10. BASS ALC : THD



8 IC1

Figure 11. PINS: IN1_L, IN1_R, IN2_L, IN2_R, IN3_L, IN3_R, IN4_L, IN4_R, IS_L, IS_R, MIC

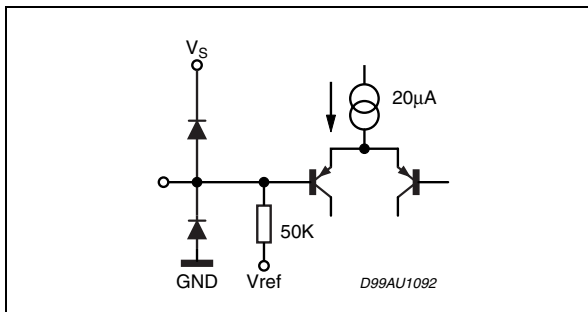

Figure 12. PINS: OUT_L, OUT_R, IMUX_L, MUX_R

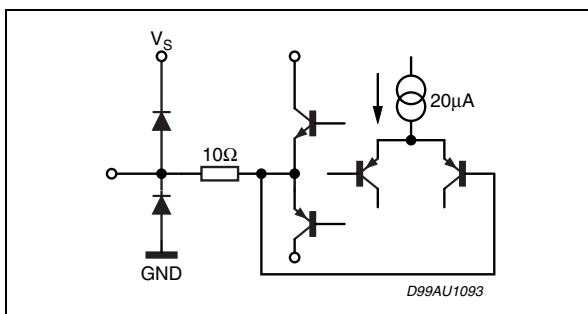

Figure 13. PINS: TREBLE_L, TREBLE_R

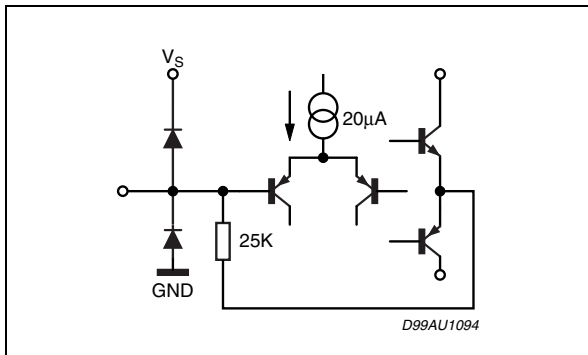

Figure 14. PINS: SCL, SDA

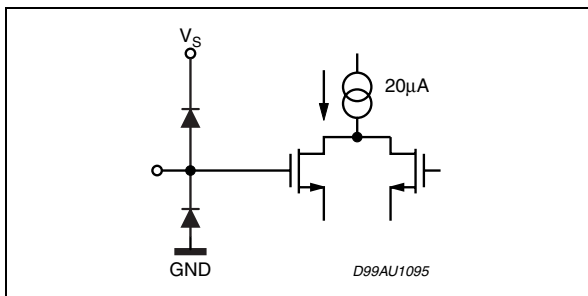

Figure 15. PINS: BASSI_L, BASSI_R

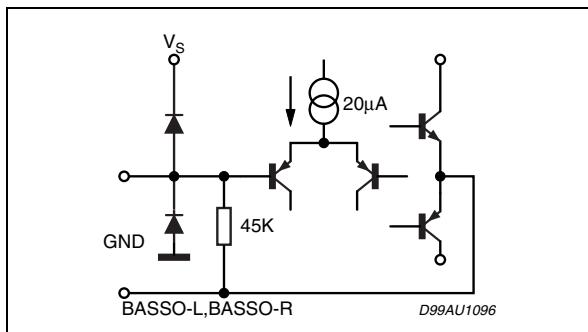

Figure 16. PINS: BASSO_L, BASSO_R

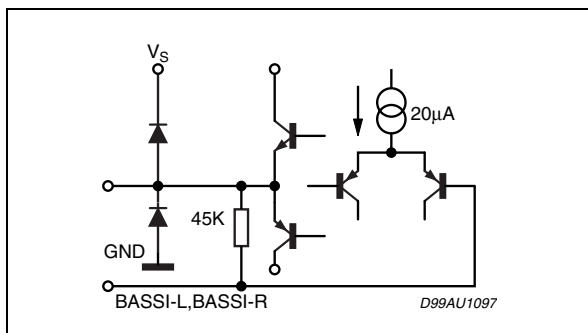

Figure 17. PIN: ALC

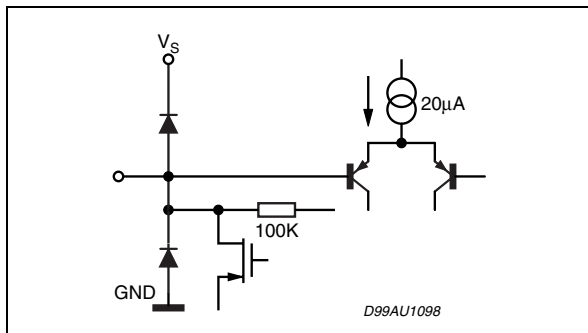
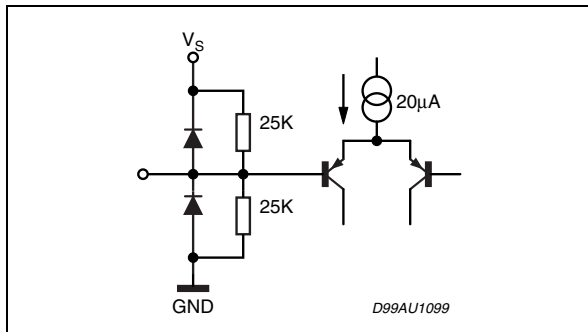

Figure 18. PIN: CREF



9 PACKAGE MECHANICAL DATA

In order to meet environmental requirements, ST offers these devices in different grades of ECOPACK[®] packages, depending on their level of environmental compliance. ECOPACK[®] specifications, grade definitions and product status are available at: www.st.com. ECOPACK[®] is an ST trademark.

Figure 19. SO28 Mechanical Data & Package Dimensions

DIM.	mm			inch		
	MIN.	TYP.	MAX.	MIN.	TYP.	MAX.
A			2.65			0.104
a1	0.1		0.3	0.004		0.012
b	0.35		0.49	0.014		0.019
b1	0.23		0.32	0.009		0.013
C		0.5			0.020	
c1	45° (typ.)					
D	17.7		18.1	0.697		0.713
E	10		10.65	0.394		0.419
e		1.27			0.050	
e3		16.51			0.65	
F	7.4		7.6	0.291		0.299
L	0.4		1.27	0.016		0.050
S	8° (max.)					

OUTLINE AND MECHANICAL DATA

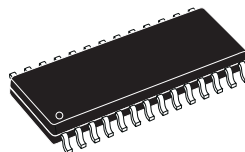

SO-28

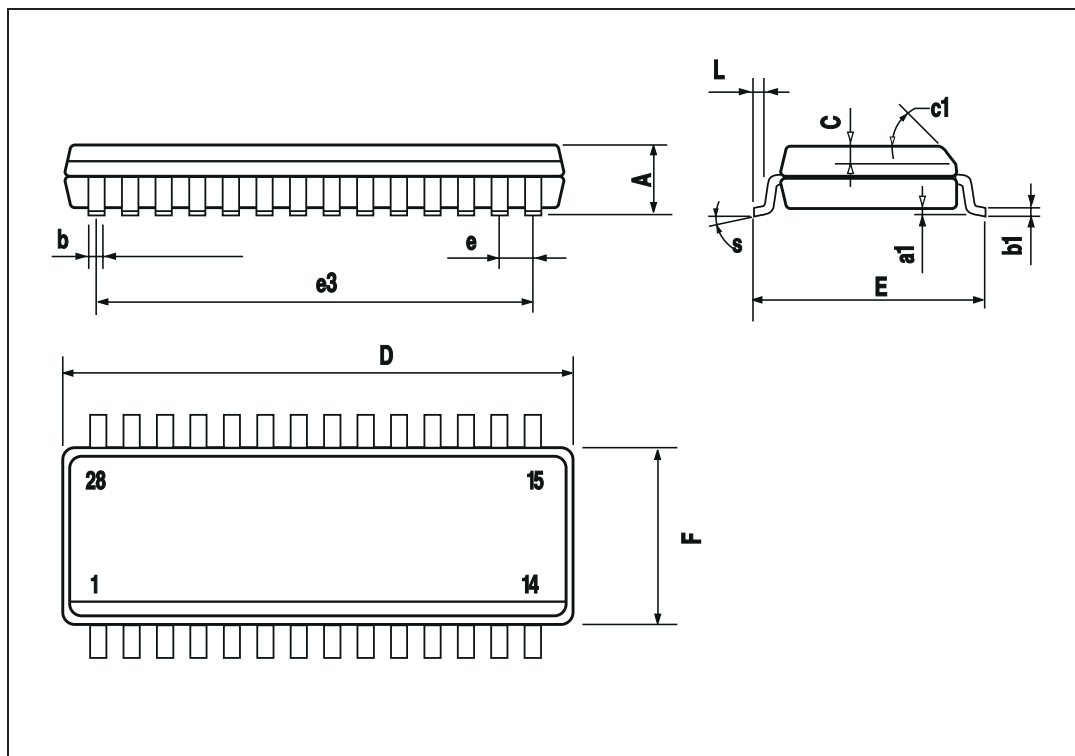

10 REVISION HISTORY

Table 16. Revision History

Date	Revision	Description of Changes
January 2004	1	First Issue in EDOCS DMS
June 2004	2	Changed the Style-sheet in compliance to the new "Corporate Technical Publications Design Guide"
March 2006	3	Updated figure 19 "SO28 Mechanical Data & Package Dimensions"
30-Apr-2010	4	Updated title and added environmental compliance statement for package

Please Read Carefully:

Information in this document is provided solely in connection with ST products. STMicroelectronics NV and its subsidiaries ("ST") reserve the right to make changes, corrections, modifications or improvements, to this document, and the products and services described herein at any time, without notice.

All ST products are sold pursuant to ST's terms and conditions of sale.

Purchasers are solely responsible for the choice, selection and use of the ST products and services described herein, and ST assumes no liability whatsoever relating to the choice, selection or use of the ST products and services described herein.

No license, express or implied, by estoppel or otherwise, to any intellectual property rights is granted under this document. If any part of this document refers to any third party products or services it shall not be deemed a license grant by ST for the use of such third party products or services, or any intellectual property contained therein or considered as a warranty covering the use in any manner whatsoever of such third party products or services or any intellectual property contained therein.

UNLESS OTHERWISE SET FORTH IN ST'S TERMS AND CONDITIONS OF SALE ST DISCLAIMS ANY EXPRESS OR IMPLIED WARRANTY WITH RESPECT TO THE USE AND/OR SALE OF ST PRODUCTS INCLUDING WITHOUT LIMITATION IMPLIED WARRANTIES OF MERCHANTABILITY, FITNESS FOR A PARTICULAR PURPOSE (AND THEIR EQUIVALENTS UNDER THE LAWS OF ANY JURISDICTION), OR INFRINGEMENT OF ANY PATENT, COPYRIGHT OR OTHER INTELLECTUAL PROPERTY RIGHT.

UNLESS EXPRESSLY APPROVED IN WRITING BY AN AUTHORIZED ST REPRESENTATIVE, ST PRODUCTS ARE NOT RECOMMENDED, AUTHORIZED OR WARRANTED FOR USE IN MILITARY, AIR CRAFT, SPACE, LIFE SAVING, OR LIFE SUSTAINING APPLICATIONS, NOR IN PRODUCTS OR SYSTEMS WHERE FAILURE OR MALFUNCTION MAY RESULT IN PERSONAL INJURY, DEATH, OR SEVERE PROPERTY OR ENVIRONMENTAL DAMAGE. ST PRODUCTS WHICH ARE NOT SPECIFIED AS "AUTOMOTIVE GRADE" MAY ONLY BE USED IN AUTOMOTIVE APPLICATIONS AT USER'S OWN RISK.

Resale of ST products with provisions different from the statements and/or technical features set forth in this document shall immediately void any warranty granted by ST for the ST product or service described herein and shall not create or extend in any manner whatsoever, any liability of ST.

ST and the ST logo are trademarks or registered trademarks of ST in various countries.

Information in this document supersedes and replaces all information previously supplied.

The ST logo is a registered trademark of STMicroelectronics. All other names are the property of their respective owners.

© 2010 STMicroelectronics - All rights reserved

STMicroelectronics group of companies

Australia - Belgium - Brazil - Canada - China - Czech Republic - Finland - France - Germany - Hong Kong - India - Israel - Italy - Japan - Malaysia - Malta - Morocco - Philippines - Singapore - Spain - Sweden - Switzerland - United Kingdom - United States of America

www.st.com