



Chipsmall Limited consists of a professional team with an average of over 10 year of expertise in the distribution of electronic components. Based in Hongkong, we have already established firm and mutual-benefit business relationships with customers from,Europe,America and south Asia,supplying obsolete and hard-to-find components to meet their specific needs.

With the principle of "Quality Parts,Customers Priority,Honest Operation,and Considerate Service",our business mainly focus on the distribution of electronic components. Line cards we deal with include Microchip,ALPS,ROHM,Xilinx,Pulse,ON,Everlight and Freescale. Main products comprise IC,Modules,Potentiometer,IC Socket,Relay,Connector.Our parts cover such applications as commercial,industrial, and automotives areas.

We are looking forward to setting up business relationship with you and hope to provide you with the best service and solution. Let us make a better world for our industry!



## Contact us

Tel: +86-755-8981 8866 Fax: +86-755-8427 6832

Email & Skype: info@chipsmall.com Web: www.chipsmall.com

Address: A1208, Overseas Decoration Building, #122 Zhenhua RD., Futian, Shenzhen, China





# TDA7490L

## 20W + 20W STEREO CLASS-D AMPLIFIER 40W MONO IN BTL

### 1 FEATURES

- 20W + 20W OUTPUT POWER:  
@  $R_L = 8\Omega/4\Omega$ ; THD = 10%
- HIGH EFFICIENCY
- WIDE SUPPLY VOLTAGE RANGE (FROM  $\pm 10$  TO  $\pm 25V$ )
- SPLIT SUPPLY, SINGLE SUPPLY OPERATION
- TURN OFF/ON POP FREE
- ST-BY AND MUTE FEATURES
- SHORT CIRCUIT PROTECTION ACROSS THE LOAD
- THERMAL OVERLOAD PROTECTION
- EXTERNALLY SYNCHRONIZABLE
- BRIDGE CONFIGURATION

Figure 1. Package



Table 1. Order Codes

Part Number	Package
TDA7490L	Flexiwatt 25

### 2 DESCRIPTION

The TDA7490L is a dual audio class D amplifier assembled in Flexiwatt 25 package; it is specially designed for high efficiency application mainly for TV and Home Stereo sets.

Figure 2. Test and Application Circuit. (Stereo Configuration)

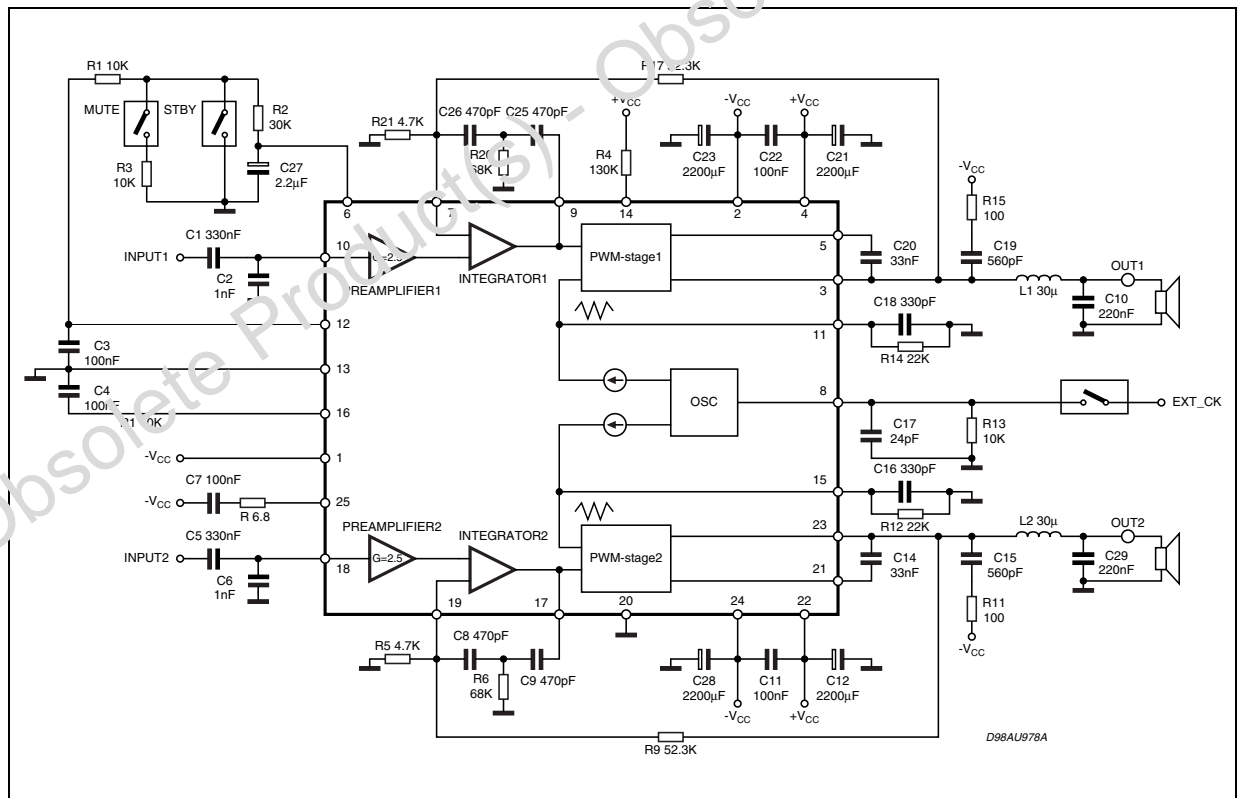

Figure 3. Test and Application Circuit. (Bridge Configuration)

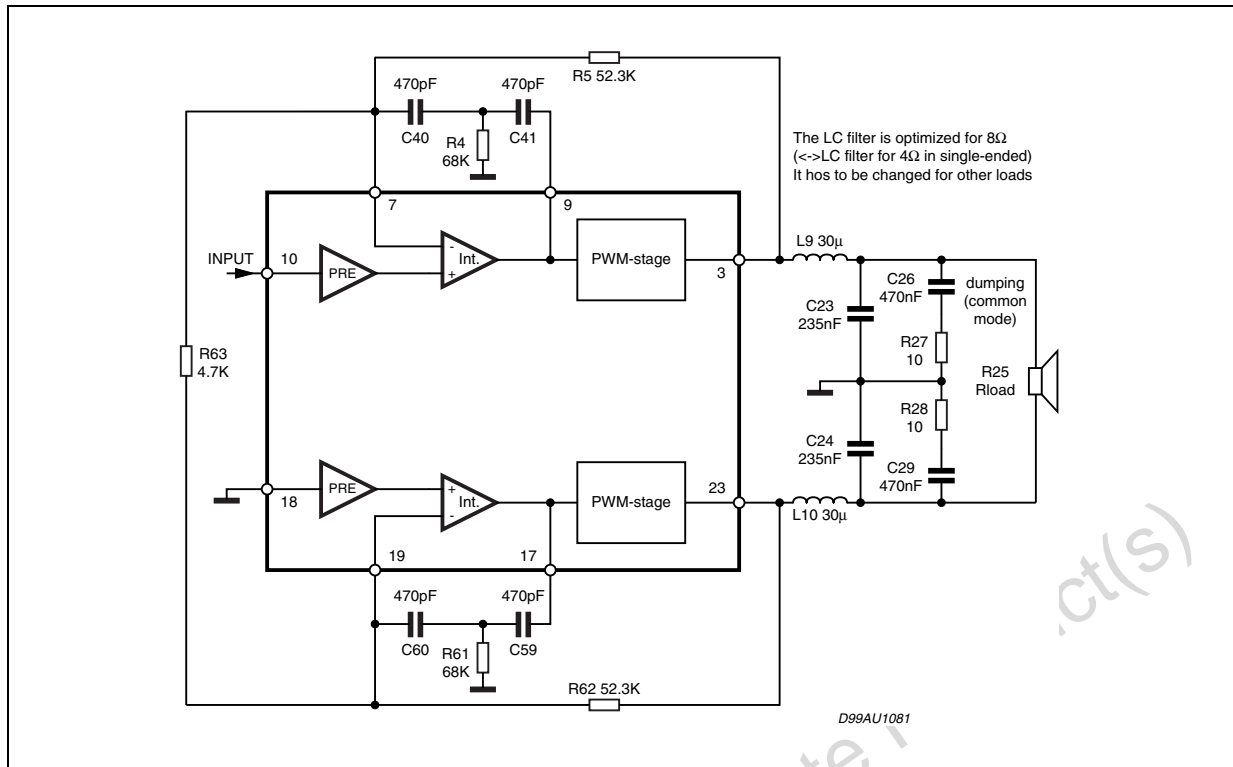

Table 2. Absolute Maximum Ratings

Symbol	Parameter	Value	Unit
V <sub>CC</sub>	DC Supply Voltage (no signal)	±30	V
P <sub>tot</sub>	Power Dissipation T <sub>case</sub> = 70°C	35	W
T <sub>stg</sub> , T <sub>j</sub>	Storage and Junction Temperature	-40 to 150	°C
T <sub>op</sub>	Operating Temperature Range	0 to 70	°C
V <sub>6,8,10,18</sub>	Maximum Voltage on pins # 6,8,10,18 referred to GND	±5	V

Table 3. Thermal Data

Symbol	Parameter	Value	Unit
R <sub>th j-case</sub>	Thermal Resistance Junction-case	Typ. 1	°C/W

Figure 4. Application in Supply Voltage

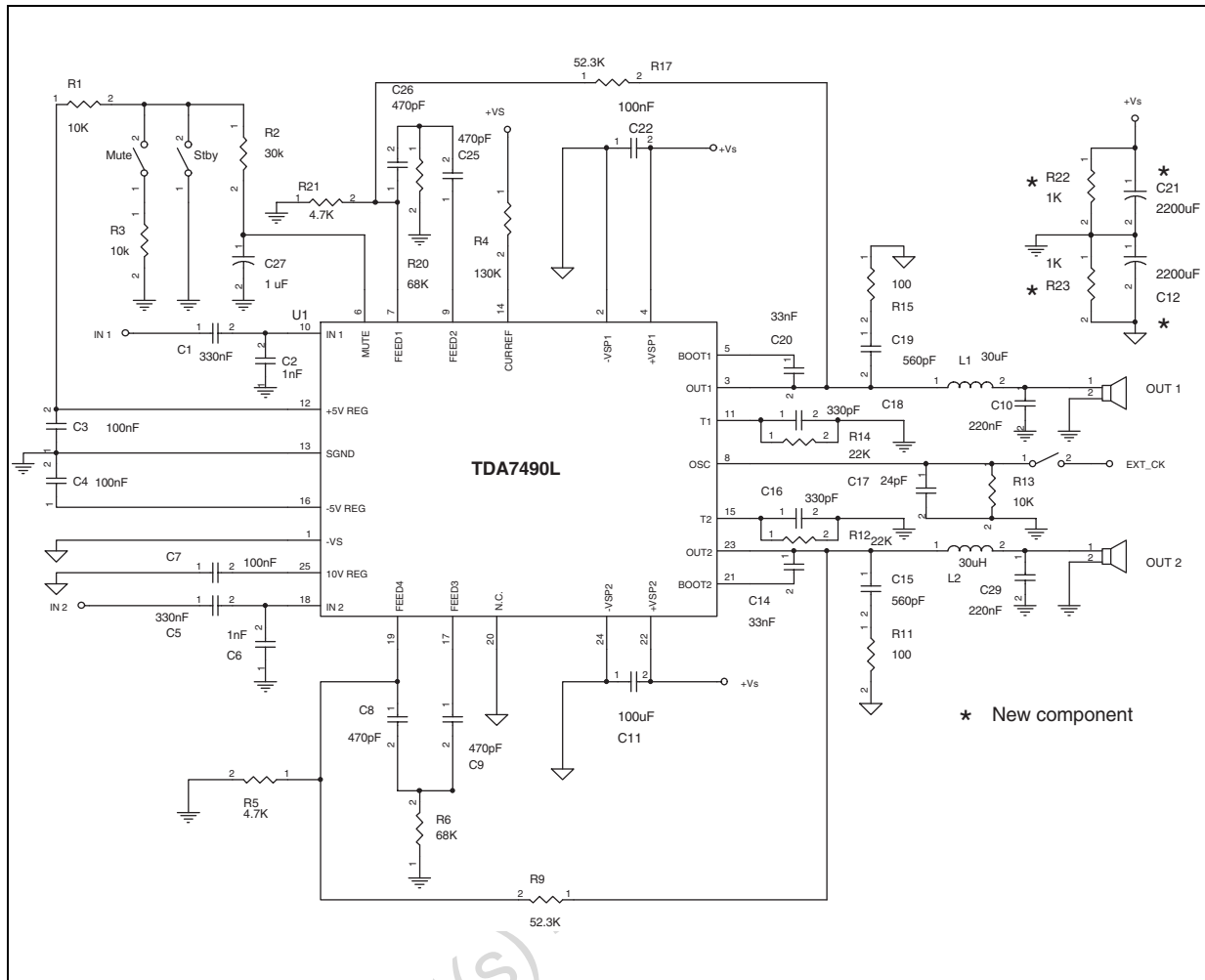

Obsolete Product(s)

Figure 5. Pin Connection

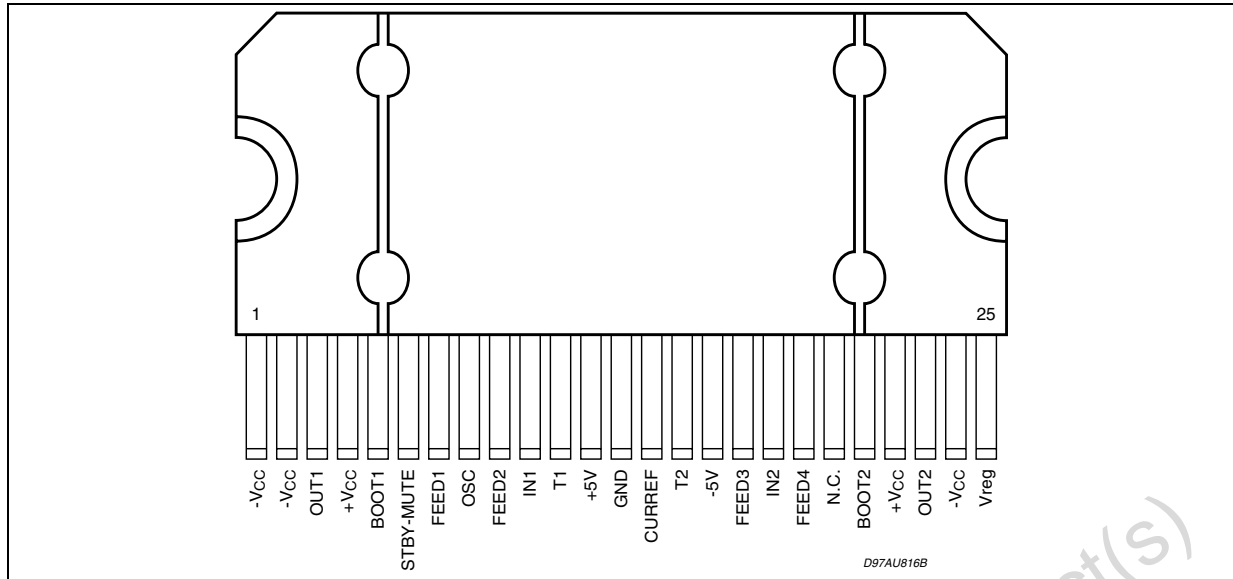

Table 4. Pin Description

Pin N°	Name	Function
1	-V <sub>CC</sub> sign/sub	Negative signal/substrate supply
2	-V <sub>CCpow1</sub>	Negative power supply CH1
3	out 1	PWM output of CH1
4	+V <sub>CCpow1</sub>	Positive power supply CH1
5	BOOT1	Bootstrap CH1
6	STBY-MUTE	Control State Pin
7	FEED1	Feedback pin 1 CH1
8	OSC	Master Oscillator Setting Freequency Pin (or external sync.)
9	FEED2	Feedback pin2 CH1
10	IN1	Input CH1
11	T1	Triangular waveform CH1
12	+5V	+5V regulator (only for internal purposes)
13	GND	Signal ground
14	CUREF	Setting current resistor
15	T2	Triangular waveform CH2
16	-5V	-5V regulator (only for internal purposes)
17	FEED3	Feedback pin1 CH2
18	IN2	Input CH2
19	FEED4	Feedback pin2 CH2
20	NC	Not connected
21	BOOT2	Bootstrap CH2
22	+V <sub>CCpow2</sub>	Positive power supply CH2
23	OUT2	PWM output of CH2
24	-V <sub>CCpow2</sub>	Negative power supply CH2
25	V <sub>reg</sub>	10V regulator

**Table 5. Electrical Characteristics**

(Refer to the test circuit,  $V_{CC} = \pm 19V$ ;  $R_L = 8\Omega$ ; Demod. filter  $L = 30\mu H$ ,  $C = 220nF$ ;  $f = 1KHz$ ;  $f_{sw} = 200kHz$ ;  $T_{amb} = 25^\circ C$  unless otherwise specified.)

Symbol	Parameter	Test Condition	Min.	Typ.	Max.	Unit
$V_S$	Supply Range		$\pm 10$		$\pm 25$	V
$I_q$	Total Quiescent Current	$R_L = \infty$ no LC filter		70	120	mA
$V_{OS}$	Output Offset Voltage		-150		+150	mV
$P_o$	Output Power	THD = 10% THD= 1%		20 16		W W
$P_{o(BTL)}$	Output Power in Bridge Configuration	$V_S = \pm 20V$ ; $R_L = 16\Omega$ THD = 10% THD=1%		40 32		W W
		$V_S = \pm 15.5V$ ; $R_L = 8\Omega$ THD = 10% THD=1%		40 32		W W
$P_o^{(1)}$	Output Power	$R_L = 4\Omega$ $V_{CC} = \pm 13.5V$ THD = 10% THD=1%		18 14.5		W W
$P_D$	Maximum Dissipated Power	$V_{CC} = \pm 19V$ ; $R_L = 8\Omega$ $P_o = 20W + 20W$ ; THD = 10%		5.6		W
$\eta$	Efficiency (%)	$P_o = 20W + 20W$		86		%
THD	Total Harmonic Distortion	$R_L = 8\Omega$ ; $P_o = 1 W$		0.1		%
$I_{max}$	Overcurrent Protection Threshold	$R_L = 0$		5		A
$T_j$	Thermal Shut-down Junction Temperature			150		$^\circ C$
$G_v$	Closed Loop Gain		29	30	31	dB
$\Delta G_v^{(3)}$	Gain Matching		-1		+1	dB
$e_N$	Total Input Noise $R_G = 50\Omega$	A Curve $f = 20Hz$ to $22KHz$		7		$\mu V$
				12		$\mu V$
$C_T$	Cross talk	$f = 1 KHz$ , $P_o = 1W$		55		dB
$R_i$	Input Resistance		20	30		k $\Omega$
SVR	Supply Voltage Rejection	$f = 100Hz$ ; $V_r = 0.5$		60		dB
$V_{rmax}$	Overvoltage Threshold <sup>(5)</sup>			55	60	V
$T_r, T_t$	Rising and Falling Time			50	70	ns
$R_{DSON}$	Power Transistor on Resistance			0.4	0.8	$\Omega$
$F_{sw}^{(4)}$	Switching Frequency Range		100	200	230	KHz
<b>MUTE &amp; STAND-BY FUNCTIONS</b>						
$V_{ST-BY}$	Stand-by range		0		0.7	V
$V_{MUTE}$	Mute Range		1.7		2.5	V
$V_{PLAY}$	Play Range		4		5	V
$A_{MUTE}$	Mute Attenuation		55	60		dB
$I_{qST-BY}$	Quiescent Current @ Stand-by			3	5	mA

\*:  $P_o$  = measured across the load using the following inductor: COIL58120 MPPA 2 (magnetics) TURNS=  $20\varnothing 1 mm$

(1)  $L = 15\mu H$ ,  $C = 470nF$

(3)  $\Delta G_v$  is intended with R2, R17, R5, R9 1% precision

(4)  $F_{sw} = 0.25 \cdot (1/(300ns + R13 \cdot (C17 + 76pF)) \cdot 0.85)$

(5)  $V_{RMAX} = (+V_{CC}) - (-V_{CC})$  when  $V_R \geq V_{RMAX}$  the device goes in Stand-By mode

Figure 6. P.C. Board and Component Layout of the Figs. 2, 3 (for Stereo and Bridge Compatible Configuration)

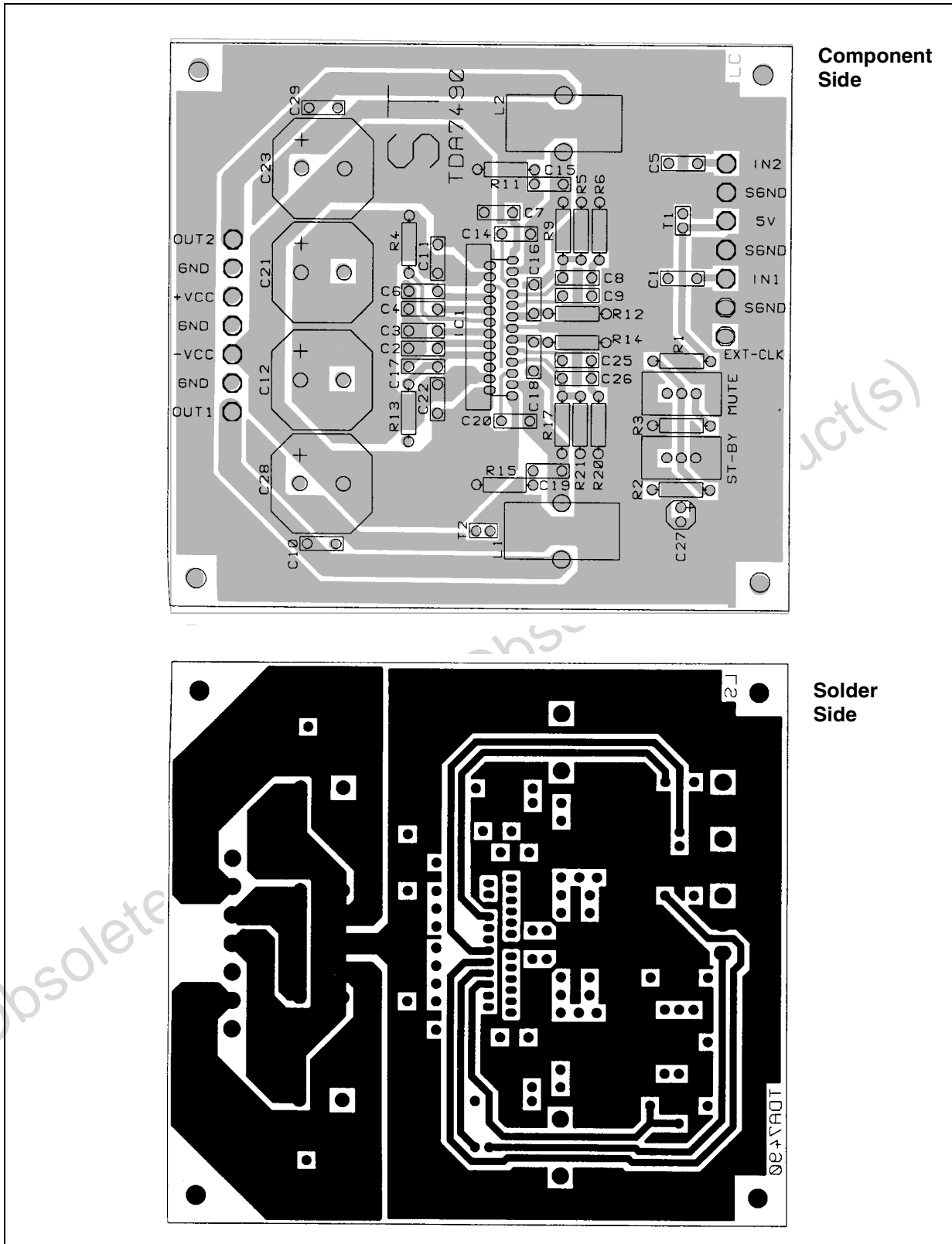

Obsolete

uct(s)

Figure 7. Distortion vs. Output Power

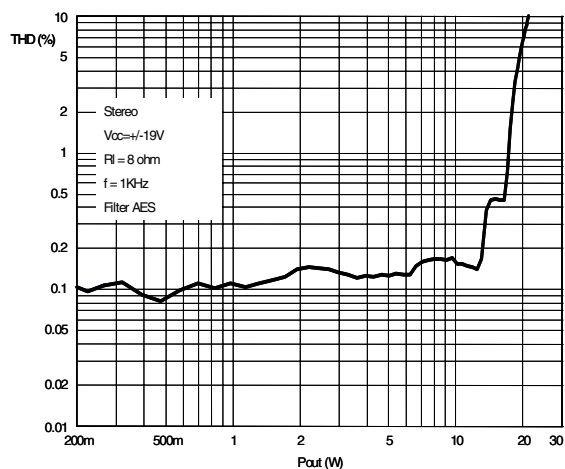

Figure 10. Frequency Response

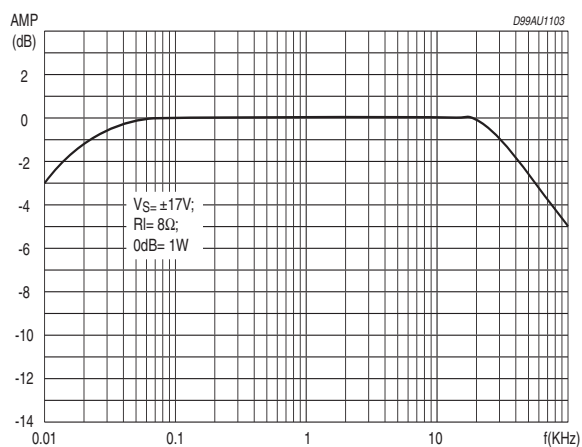

Figure 8. Distortion vs. Output Power

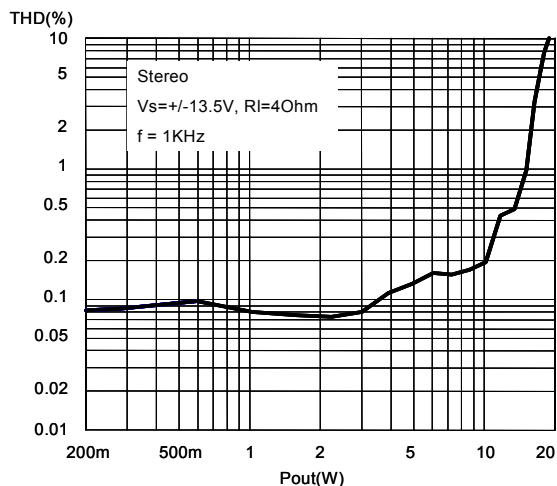

Figure 11. Power Dissipation vs. Output Power

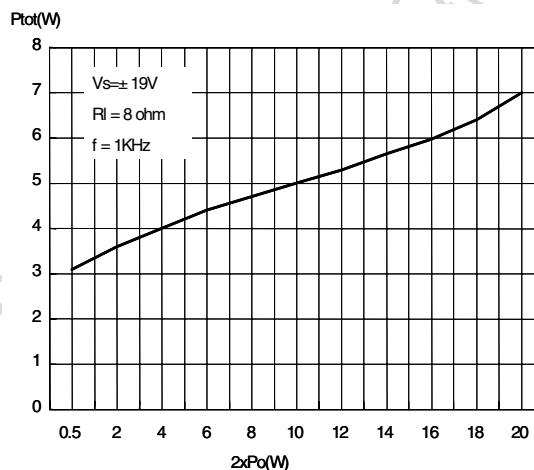

Figure 9. Crosstalk vs. Frequency

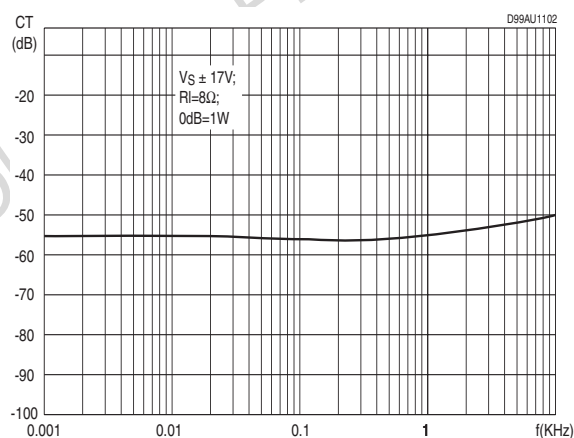

Figure 12. Distortion vs. Output Power in BTL

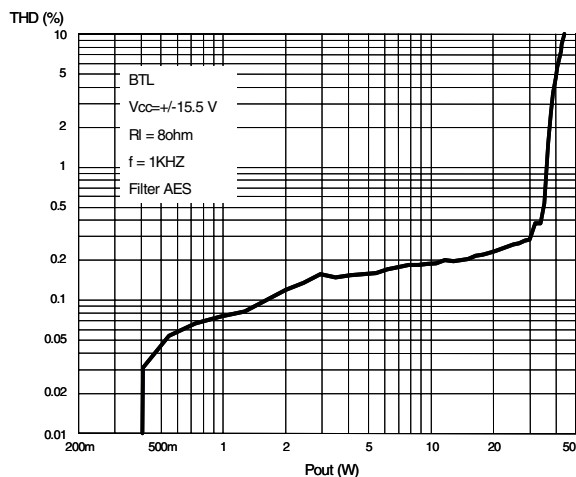



Figure 13. Distortion vs. Output Power in BTL

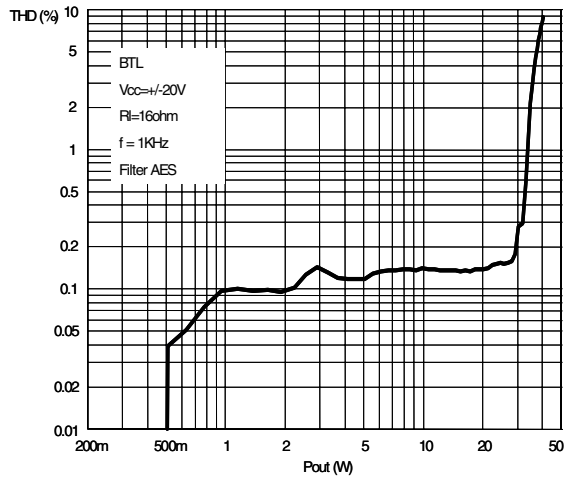
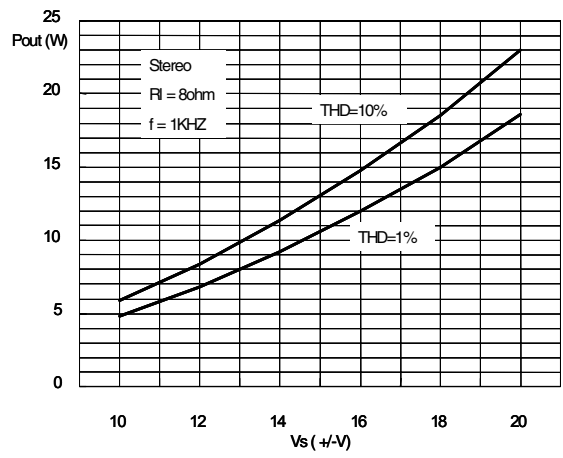

Figure 14. Pout vs Supply Voltage



Obsolete Product(s) - Obsolete Product(s)

Figure 15. Flexiwatt 25 Mechanical Data & Package Dimensions

DIM.	mm			inch		
	MIN.	TYP.	MAX.	MIN.	TYP.	MAX.
A	4.45	4.50	4.65	0.175	0.177	0.183
B	1.80	1.90	2.00	0.070	0.074	0.079
C		1.40			0.055	
D	0.75	0.90	1.05	0.029	0.035	0.041
E	0.37	0.39	0.42	0.014	0.015	0.016
F (1)			0.57			0.022
G	0.80	1.00	1.20	0.031	0.040	0.047
G1	23.75	24.00	24.25	0.935	0.945	0.955
H (2)	28.90	29.23	29.30	1.139	1.150	1.153
H1		17.00			0.669	
H2		12.80			0.503	
H3		0.80			0.031	
L (2)	22.07	22.47	22.87	0.869	0.884	0.904
L1	18.57	18.97	19.37	0.731	0.747	0.762
L2 (2)	15.50	15.70	15.90	0.610	0.618	0.626
L3	7.70	7.85	7.95	0.303	0.309	0.313
L4		5			0.197	
L5		3.5			0.138	
M	3.70	4.00	4.30	0.145	0.157	0.169
M1	3.60	4.00	4.40	0.142	0.157	0.173
N		2.20			0.086	
O		2			0.079	
R		1.70			0.067	
R1		0.5			0.02	
R2		0.3			0.12	
R3		1.25			0.049	
R4		0.50			0.019	
V					5° (T p.)	
V1					3° (Typ.)	
V2					20° (Typ.)	
V3					45° (Typ.)	

**OUTLINE AND MECHANICAL DATA**

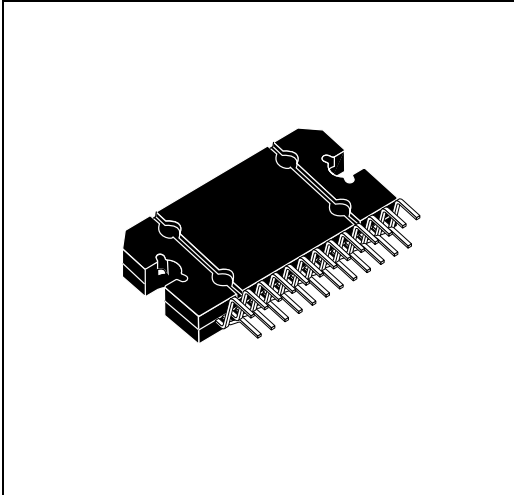

**Flexiwatt25 (vertical)**

(1): dam-bar protusion not included  
 (2): molding protusion included

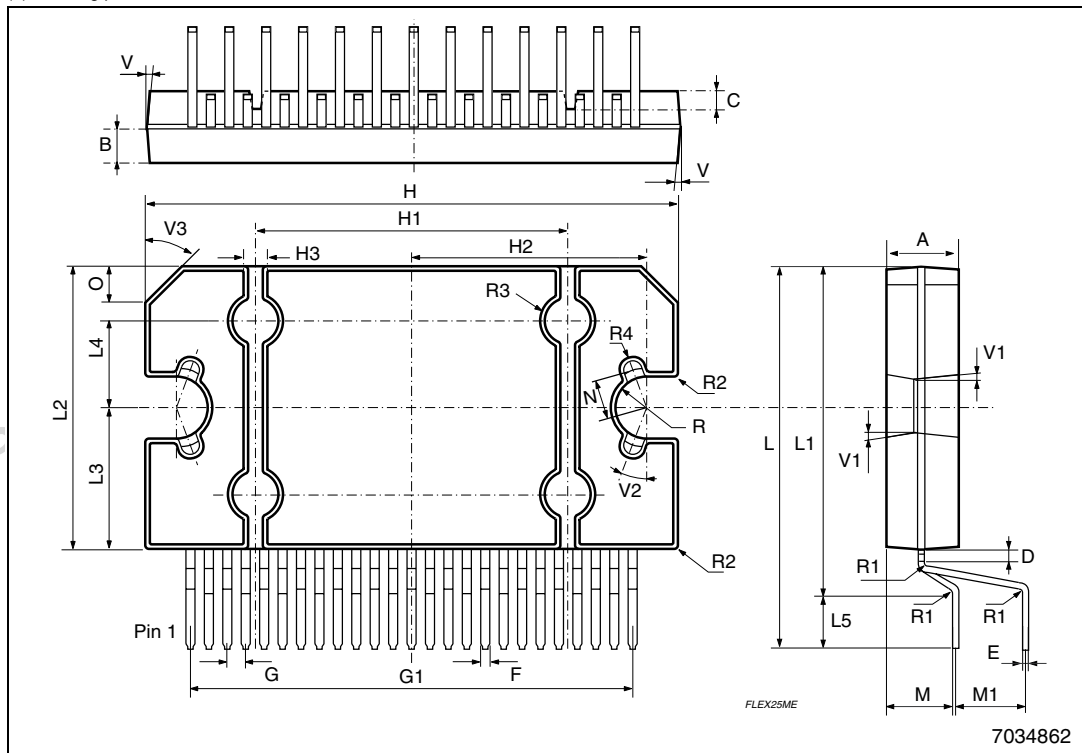

**Table 6. Revision History**

Date	Revision	Description of Changes
March 2001	1	First Issue
December 2005	2	Corrected the value of the inductance in the caption of the Table 5 "Electrical Characteristics".

Obsolete Product(s) - Obsolete Product(s)

Information furnished is believed to be accurate and reliable. However, STMicroelectronics assumes no responsibility for the consequences of use of such information nor for any infringement of patents or other rights of third parties which may result from its use. No license is granted by implication or otherwise under any patent or patent rights of STMicroelectronics. Specifications mentioned in this publication are subject to change without notice. This publication supersedes and replaces all information previously supplied. STMicroelectronics products are not authorized for use as critical components in life support devices or systems without express written approval of STMicroelectronics.

The ST logo is a registered trademark of STMicroelectronics.  
All other names are the property of their respective owners

© 2005 STMicroelectronics - All rights reserved

STMicroelectronics group of companies

Australia - Belgium - Brazil - Canada - China - Czech Republic - Finland - France - Germany - Hong Kong - India - Israel - Italy - Japan -  
Malaysia - Malta - Morocco - Singapore - Spain - Sweden - Switzerland - United Kingdom - United States of America

[www.st.com](http://www.st.com)