



Chipsmall Limited consists of a professional team with an average of over 10 year of expertise in the distribution of electronic components. Based in Hongkong, we have already established firm and mutual-benefit business relationships with customers from,Europe,America and south Asia,supplying obsolete and hard-to-find components to meet their specific needs.

With the principle of “Quality Parts,Customers Priority,Honest Operation,and Considerate Service”,our business mainly focus on the distribution of electronic components. Line cards we deal with include Microchip,ALPS,ROHM,Xilinx,Pulse,ON,Everlight and Freescale. Main products comprise IC,Modules,Potentiometer,IC Socket,Relay,Connector.Our parts cover such applications as commercial,industrial, and automotives areas.

We are looking forward to setting up business relationship with you and hope to provide you with the best service and solution. Let us make a better world for our industry!



Contact us

Tel: +86-755-8981 8866 Fax: +86-755-8427 6832

Email & Skype: info@chipsmall.com Web: www.chipsmall.com

Address: A1208, Overseas Decoration Building, #122 Zhenhua RD., Futian, Shenzhen, China





TDA7494S

10W AMPLIFIER

- 10W OUTPUT POWER $R_L = 8\Omega$,
@ THD = 10% $V_{CC} = 28V$
- ST-BY AND MUTE FUNCTIONS
- NO BOUCHEROT CELL
- NO ST-BY RC INPUT NETWORK
- SINGLE SUPPLY RANGING UP TO 35V
- SHORT CIRCUIT PROTECTION
- THERMAL OVERLOAD PROTECTION
- INTERNALLY FIXED GAIN
- SOFT CLIPPING
- LOW TURN-ON TURN-OFF POP NOISE
- MULTIWATT 15 PACKAGE

MULTIPOWER BI50II TECHNOLOGY

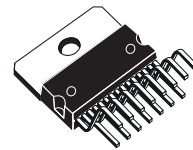

Multiwatt15

ORDERING NUMBER: TDA7494S

DESCRIPTION

The TDA7494S 10W is class AB power amplifier assembled in the @Multiwatt 15 package, spe-

cially designed for high quality sound, TV applica-

tions. Features of the TDA7494S include Stand-by and mute functions.

BLOCK AND APPLICATION DIAGRAM

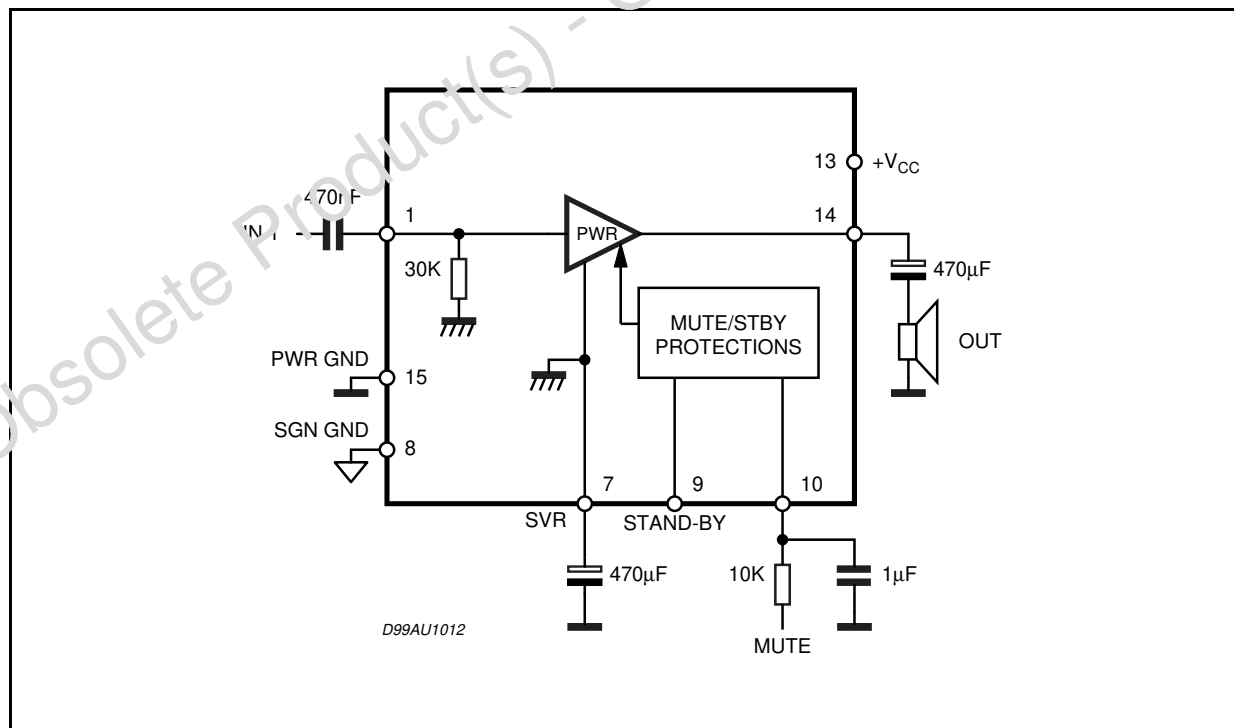

TDA7494S

ABSOLUTE MAXIMUM RATINGS

Symbol	Parameter	Value	Unit
V_S	DC Supply Voltage	40	V
V_{IN}	Maximum Input Voltage	8	V _{pp}
P_{tot}	Total Power Dissipation ($T_{amb} = 70^{\circ}C$)	16	W
T_{amb}	Ambient Operating Temperature Range (1)	-20 to +85	$^{\circ}C$
T_{stg}, T_j	Storage and Junction Temperature	-40 to 150	$^{\circ}C$

- (1) Operation between -20 to 85 $^{\circ}C$ guaranteed by correlation with 0 to 70 $^{\circ}C$.
 (2) Pin 3 is ESD sensitive (max. voltage $\pm 1.5KV$)

PIN CONNECTION

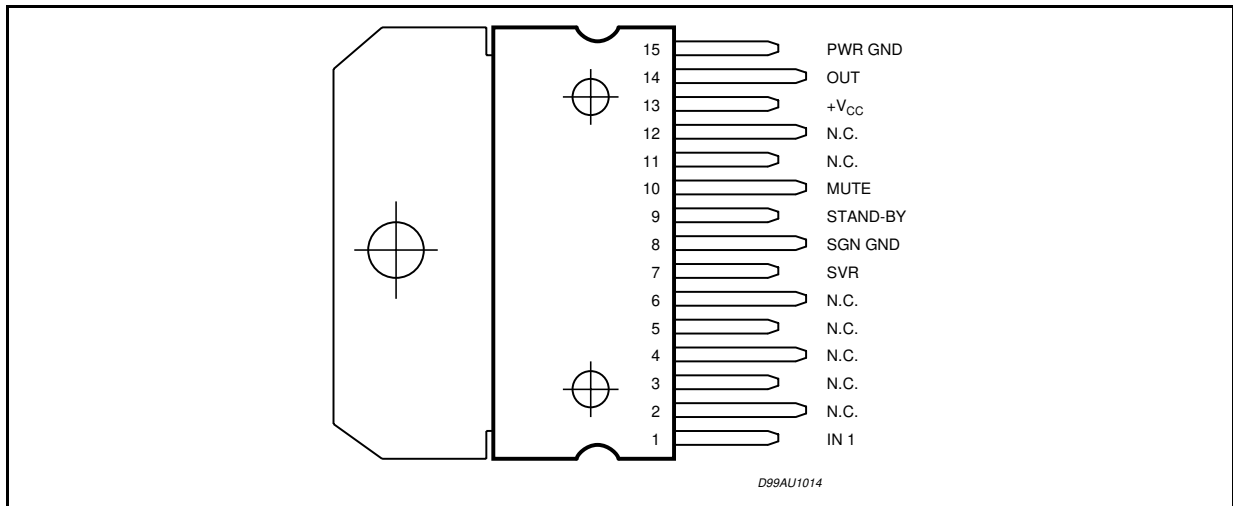

THERMAL DATA

Symbol	Parameter	Value	Unit
$R_{th\ j-case}$	Thermal Resistance Junction-case	Typ = 3.8 Max = 4.8	$^{\circ}C/W$
$R_{th\ j-amb}$	Thermal Resistance Junction-ambient	max 35	$^{\circ}C/W$

ELECTRICAL CHARACTERISTICS(Refer to the test circuit, $V_S = 21V$, $R_L = 8\Omega$; $R_g = 50\Omega$; $T_{amb} = 25^\circ C$; unless otherwise specified.)

Symbol	Parameter	Test Condition	Min.	Typ.	Max.	Unit
V_S	Supply Voltage Range		11		35	V
I_q	Total Quiescent Current			22	50	mA
DCV _{OS}	Output DC Offset Referred to SVR Potential	No Input Signal	-550		550	mV
V_o	Quiescent Output Voltage	$V_S = 18V$	7.8	9	10.2	V
		$V_S = 21V$	10	10.5	11	V
P_o	Output Power	THD = 10%; $V_{CC} = 28V$, $R_L = 8\Omega$ THD = 1%; $V_{CC} = 28V$	8 6	10 8		W
		THD = 10%; $V_{CC} = 21V$, THD = 1%; $V_{CC} = 21V$,	5 3.5	5.5 4		W
		THD = 10%; $V_{CC} = 21V$, $R_L = 4\Omega$ THD = 1%; $V_{CC} = 21V$,	5 3.9	6.6 5.5		W
		THD = 10%; $V_{CC} = 18V$, THD = 1%; $V_{CC} = 18V$	4.5 3.5	6 4.5		W
		THD = 10%; $V_{CC} = 18V$, $R_L = 8\Omega$ THD = 1%; $V_{CC} = 18V$	3.5 2.2	3.75 2.85		W W
		THD	Total Harmonic Distortion	$P_O = 1W$; $f = 1KHz$; $G_v = 26dB$		
I_{peak}	Output Peak Current	(internally limited)	1.4	1.9		A
T_{op}	Operating Temperature		0		70	$^\circ C$
V_{in}	Input Signal				2.8	V _{rms}
G_v	Closed Loop Gain		24.5	26	27.5	dB
BW				0.6		MHz
e_n	Total Output Noise	$f = 20Hz$ to 22KHz Play		30	50	μV
		$f = 20Hz$ to 22KHz Mute		30	50	μV
SR	Slew Rate		5	8		V/ μs
R_i	Input Resistance		22.5	30		K Ω
SVR	Supply Voltage Rejection	$f = 1kHz$; $C_{SVR} = 470\mu A$; $V_{RIP} = 1V_{RMS}$	36	43		dB
T_M	Thermal Muting			150		$^\circ C$
T_s	Thermal Shut-down			160		$^\circ C$
V_{ST-BY}	Stand-by threshold		2.3	2.5	2.7	V
V_{MUTE}	Mute Threshold		2.3	2.5	2.7	V
I_{qST-BY}	Quiescent Current @ Stand-by			0.6	1	mA
A_{MUTE}	Mute Attenuation		60	75		dB
$I_{stbyBIAS}$	Stand-by bias current	Stand by on; $V_{ST-BY} = 5V$; $V_{MUTE} = 5V$;		80	150	μA
		Play or Mute		2	20	μA
$I_{muteBIAS}$	Mute bias current	Mute		1.5	10	μA
		Play		0.5	5	μA

TDA7494S

Figure 1: Test and Application Circuit.

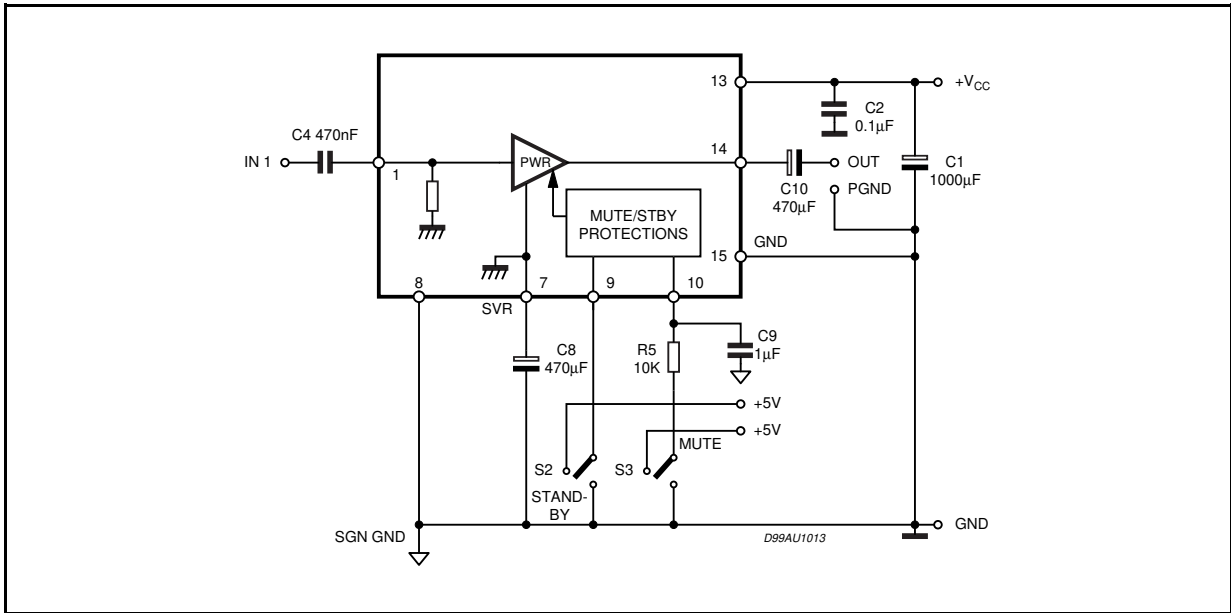
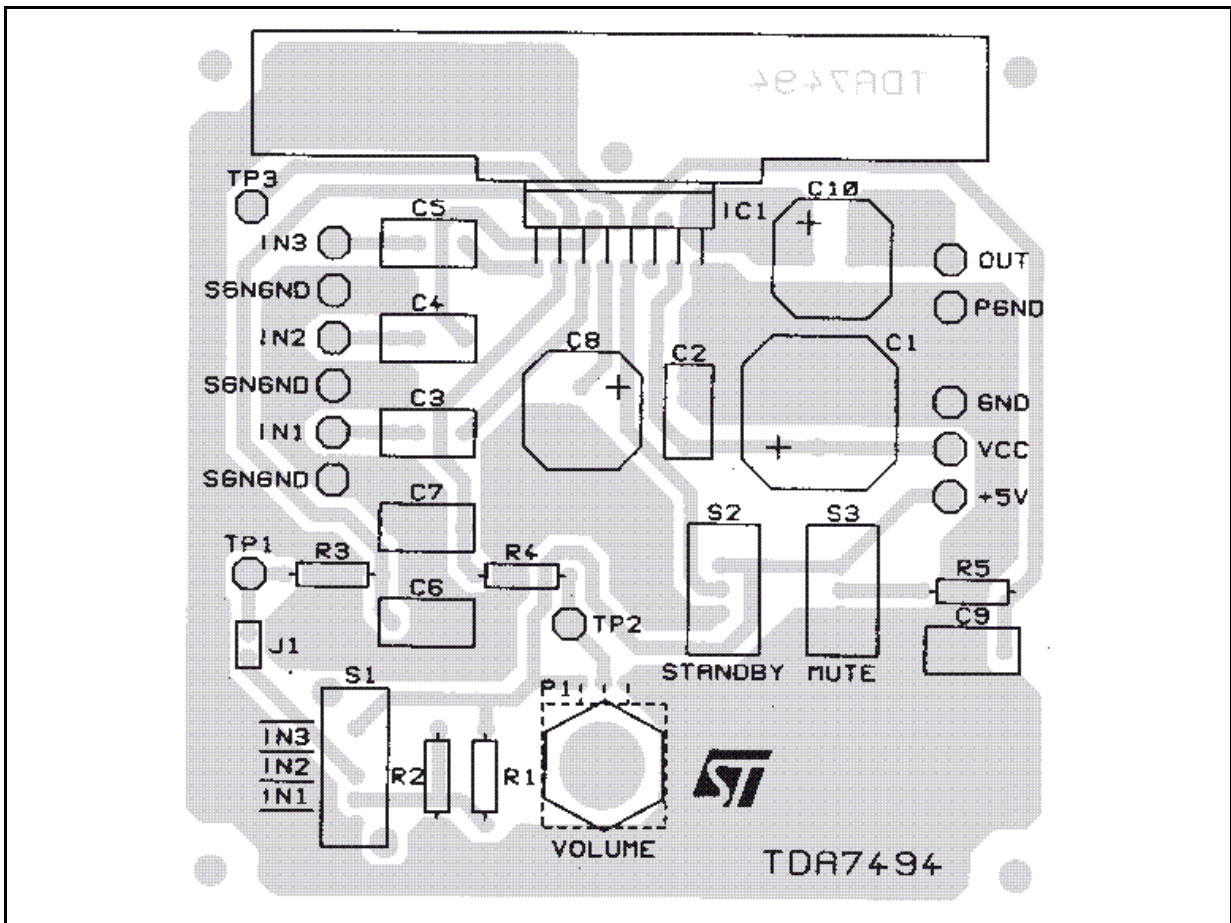

Figure 2: P.C.B. and component layout
 (Pin IN1 of relevant device must be connected to IN3 of TDA7494 Board position).



APPLICATION SUGGESTIONS

The recommended values of the external components are those shown on the application circuit of figure 1. Different values can be used; the following table can help the designer.

COMPONENT	SUGGESTION VALUE	PURPOSE	LARGER THAN SUGGESTION	SMALLER THAN SUGGESTION
R5	10K Ω	Mute time constant	Larger mute on/off time	Smaller mute on/off time
C1	1000 μ F	Supply voltage bypass		Danger of oscillation
C2	100nF	Supply voltage bypass		Danger of oscillation
C5	470nF	Input DC decoupling	Lower low frequency cutoff	Higher low frequency cutoff
C8	470 μ F	Ripple Rejection	Better SVR	Worse SVR
C9	1 μ F	Mute time constant	Larger mute on/off time	Smaller mute on/off time
C10	470 μ F	Output DC decoupling	Lower low frequency cutoff	Higher low frequency cutoff

TYPICAL CHARACTERISTICS: Refer to the Application Circuit of Fig.1 $V_S = 21V$; $R_L = 8\Omega$; $f = 1KHz$; $R_s = 8\Omega$; $T_{amb} = 25^\circ C$; $R_s = 50\Omega$; unless otherwise specified

Figure 3: Output Power vs Supply Voltage

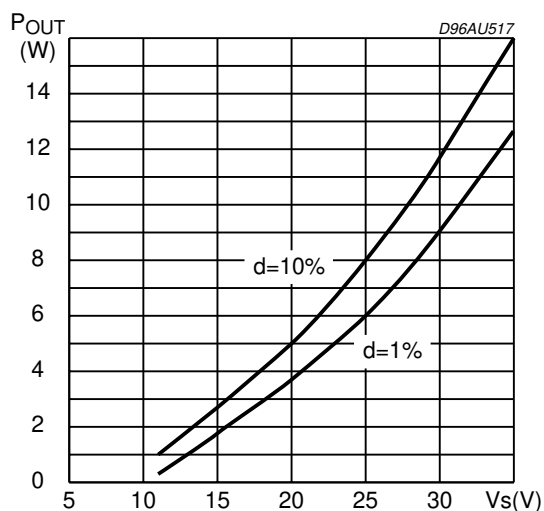

Figure 4: Distortion vs Output Power

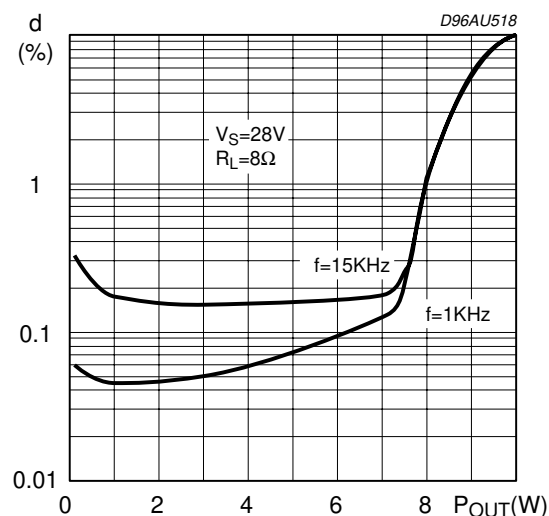

Figure 5: Output Power vs Supply Voltage

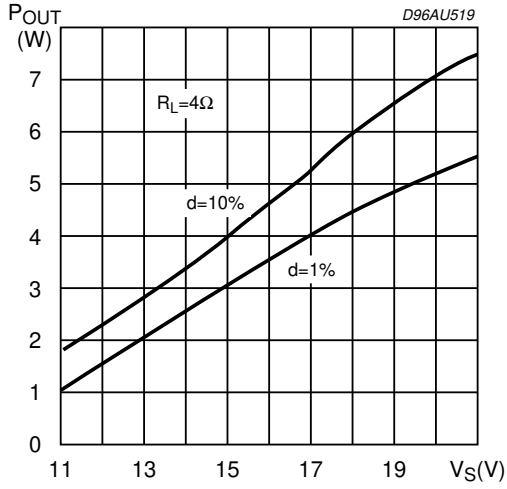

Figure 6: Distortion vs Output Power

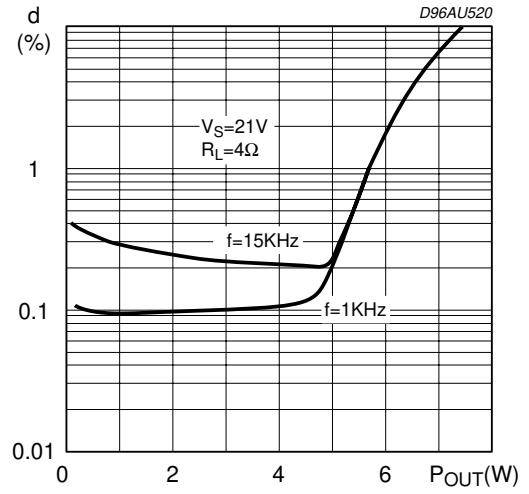

Figure 7: Distortion vs Frequency

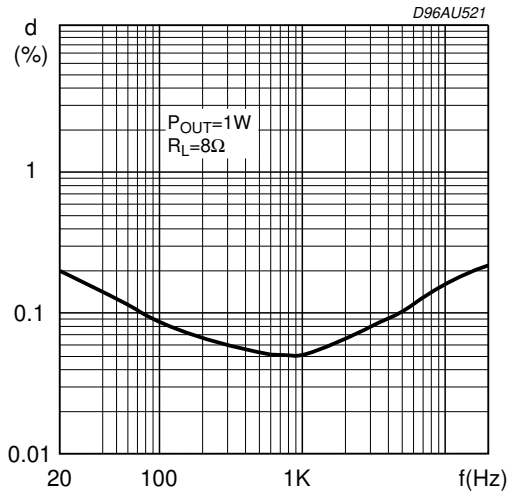

Figure 8: Distortion vs Frequency

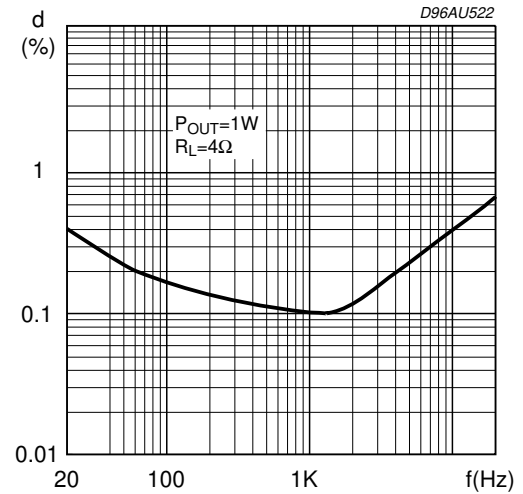

Figure 9: Quiescent Current vs Supply Voltage

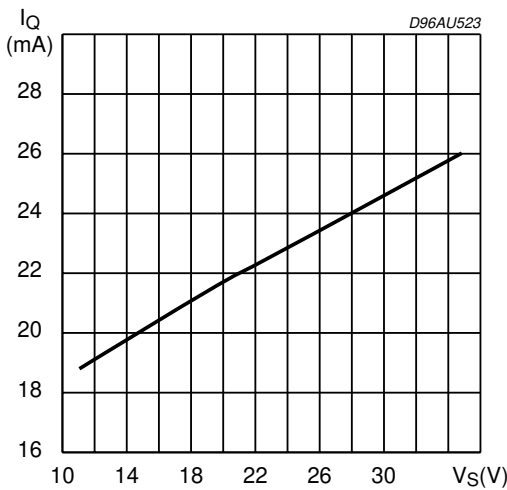

Figure 10: Quiescent Output Voltage vs Supply Voltage

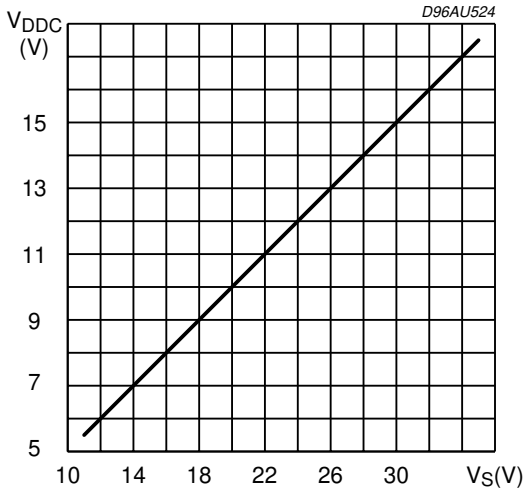

Figure 11: Stand-by Attenuation vs Vpin # 9

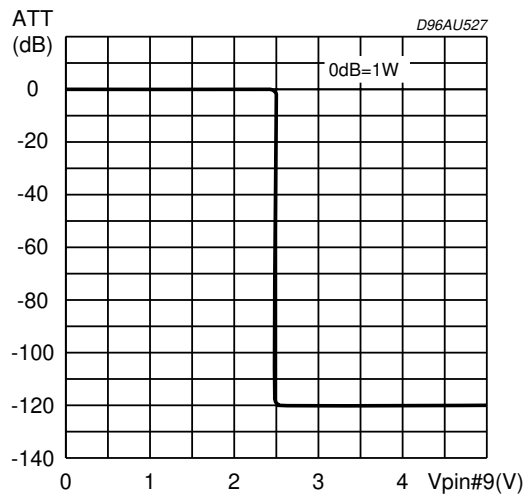

Figure 13: Power Dissipation vs Output Power

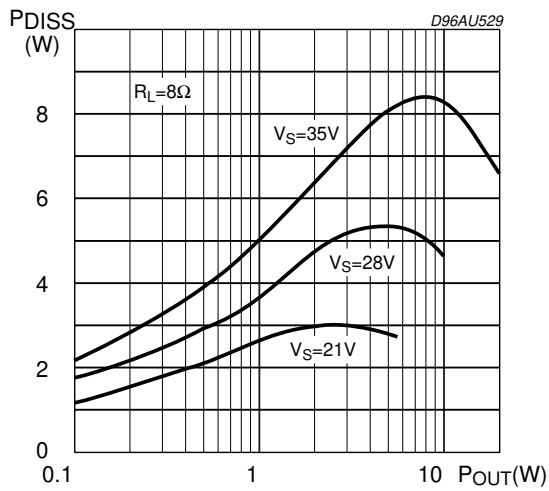

Figure 12: Mute Attenuation vs Vpin # 10

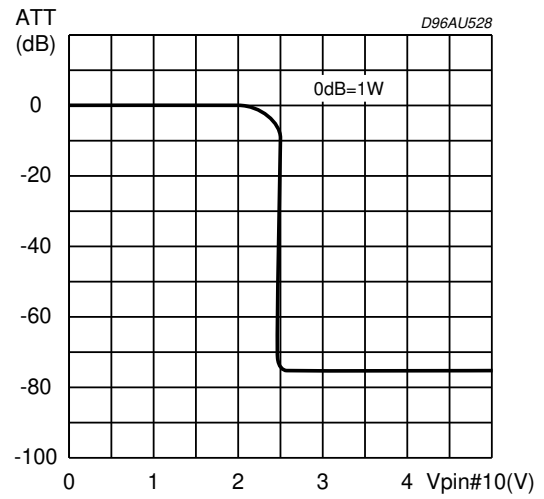
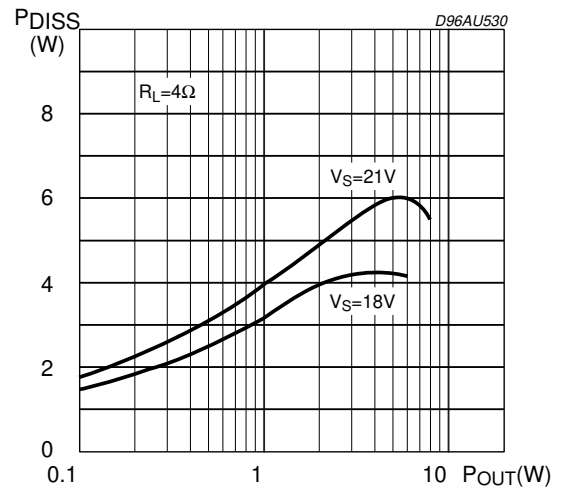

Figure 14: Power Dissipation vs Output Power



MUTE STAND-BY TRUTH TABLE

MUTE	ST-BY	OPERATING CONDITION
H	H	STANDBY
L	H	STANDBY
H	L	MUTE
L	L	PLAY

Turn ON/OFF Sequences (for optimising the POP performances)

A) USING MUTE AND STAND-BY FUNCTIONS

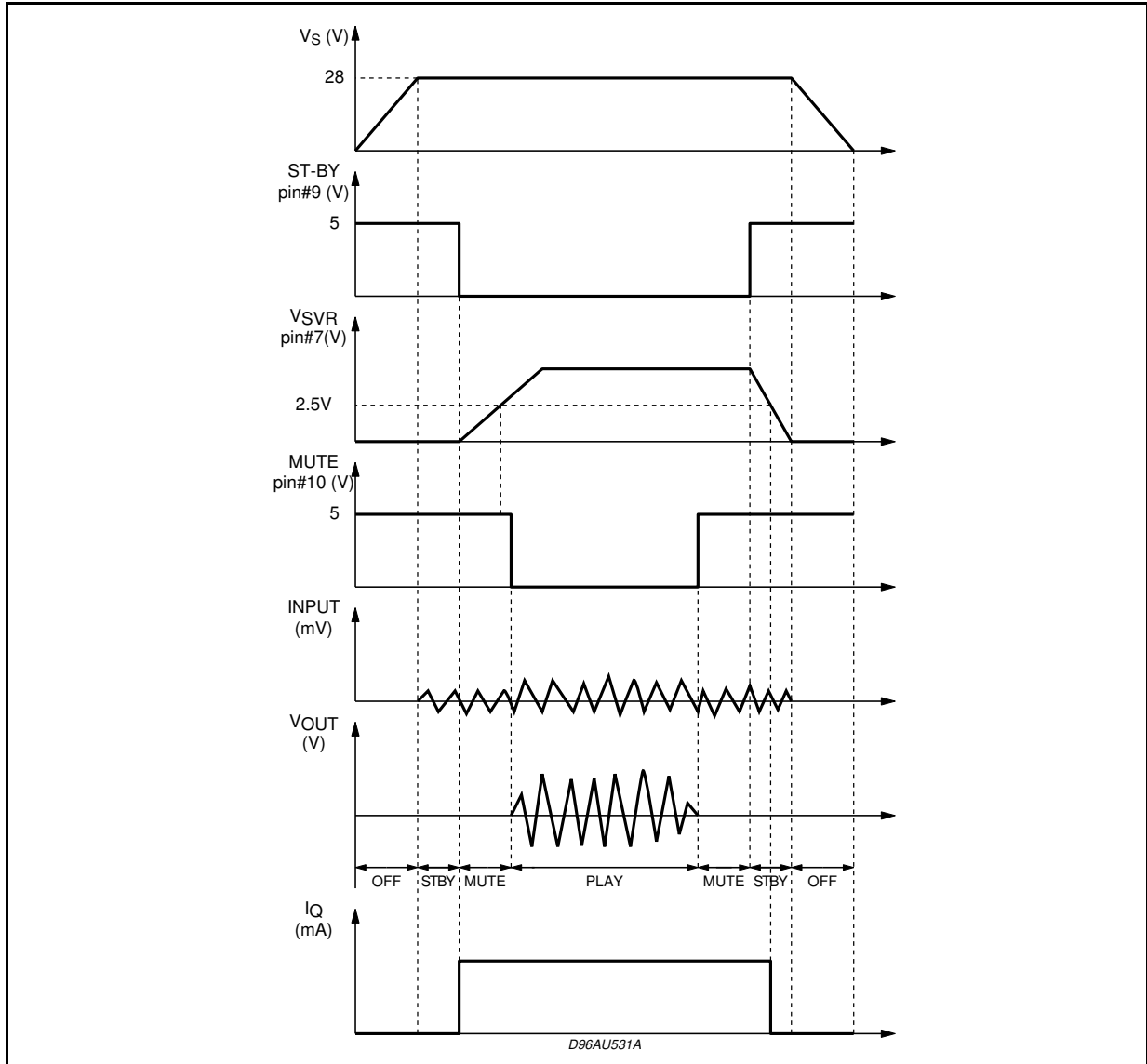

B) USING ONLY THE MUTE FUNCTION

To simplify the application, the stand-by pin can be connected directly to Ground.

During the ON/OFF transitions we recommend to respect the following conditions:

- At the turn-on the transition mute to play must be made when the SVR pin is higher than 2.5V
- At the turn-off the TDA7494S must be brought to mute from the play condition when the SVR pin is higher than 2.5V.

PINS: IN1

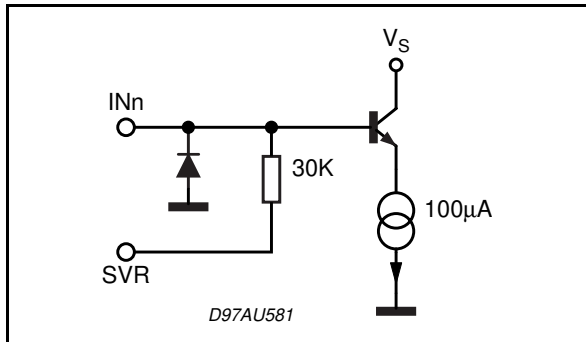

PIN: SVR

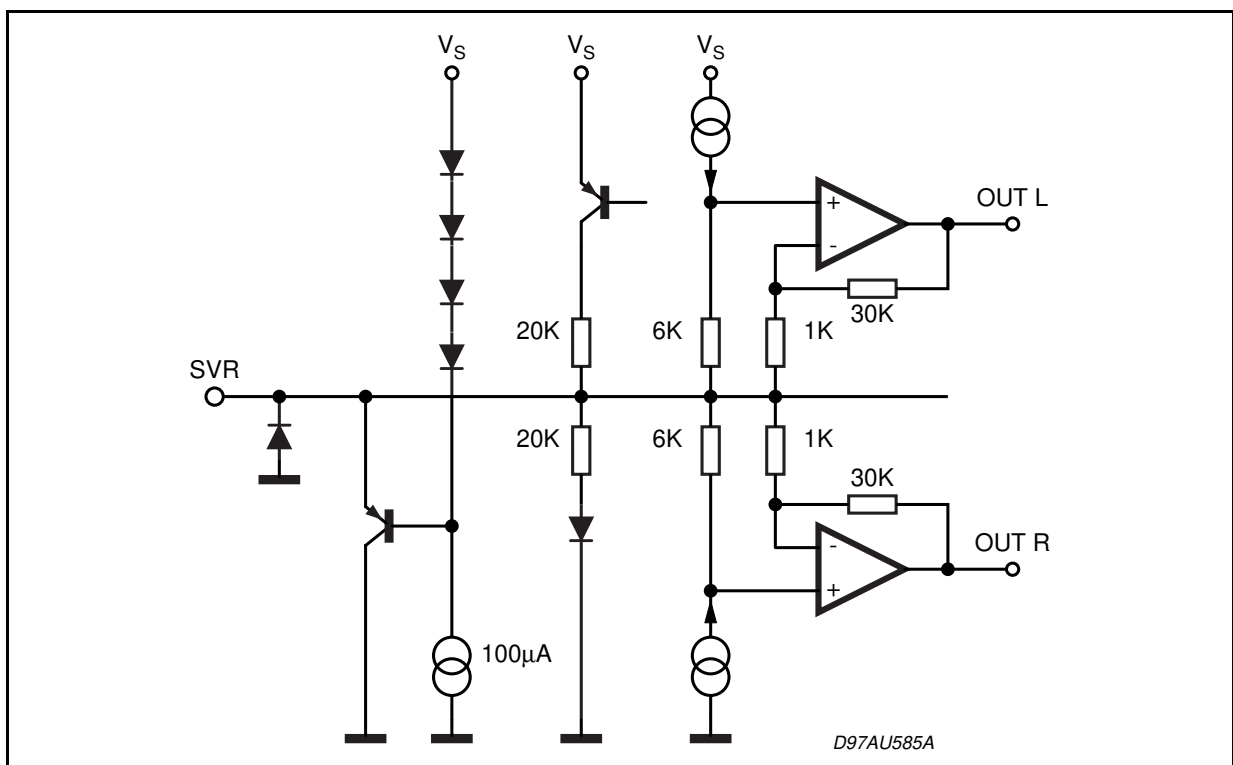

TDA7494S

PIN: ST-BY

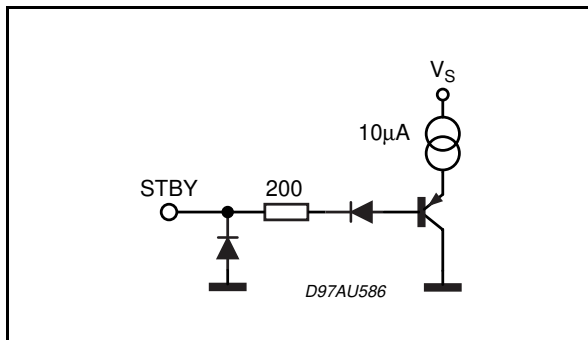

PIN: MUTE

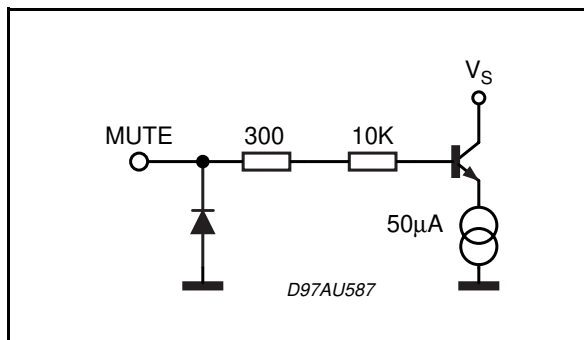

PIN: OUT

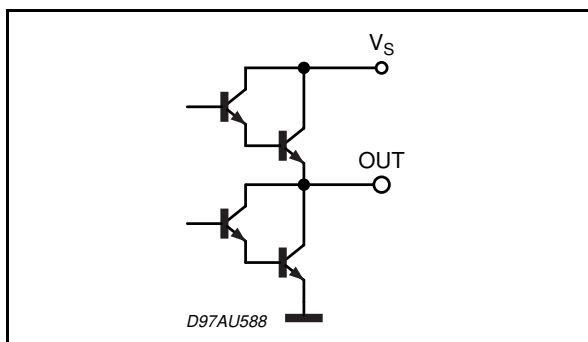

PINS: PW-GND, S-GND

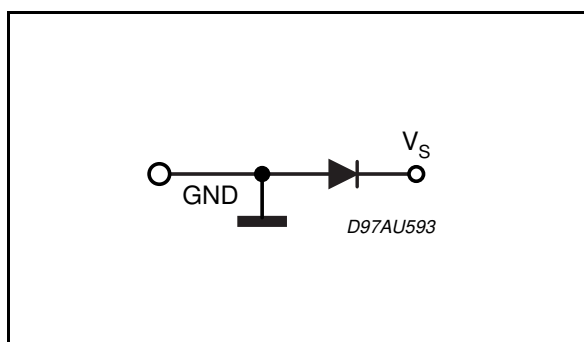

DIM.	mm			inch		
	MIN.	TYP.	MAX.	MIN.	TYP.	MAX.
A			5			0.197
B			2.65			0.104
C			1.6			0.063
D		1			0.039	
E	0.49		0.55	0.019		0.022
F	0.66		0.75	0.026		0.030
G	1.02	1.27	1.52	0.040	0.050	0.060
G1	17.53	17.78	18.03	0.690	0.700	0.710
H1	19.6			0.772		
H2			20.2			0.795
L	21.9	22.2	22.5	0.862	0.874	0.886
L1	21.7	22.1	22.5	0.854	0.870	0.886
L2	17.65		18.1	0.695		0.713
L3	17.25	17.5	17.75	0.679	0.689	0.699
L4	10.3	10.7	10.9	0.406	0.421	0.429
L7	2.65		2.9	0.104		0.114
M	4.25	4.55	4.85	0.167	0.179	0.191
M1	4.63	5.08	5.53	0.182	0.200	0.218
S	1.9		2.6	0.075		0.102
S1	1.9		2.6	0.075		0.102
Dia1	3.65		3.85	0.144		0.152

OUTLINE AND MECHANICAL DATA

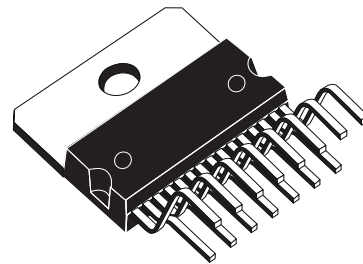

Multiwatt15 V

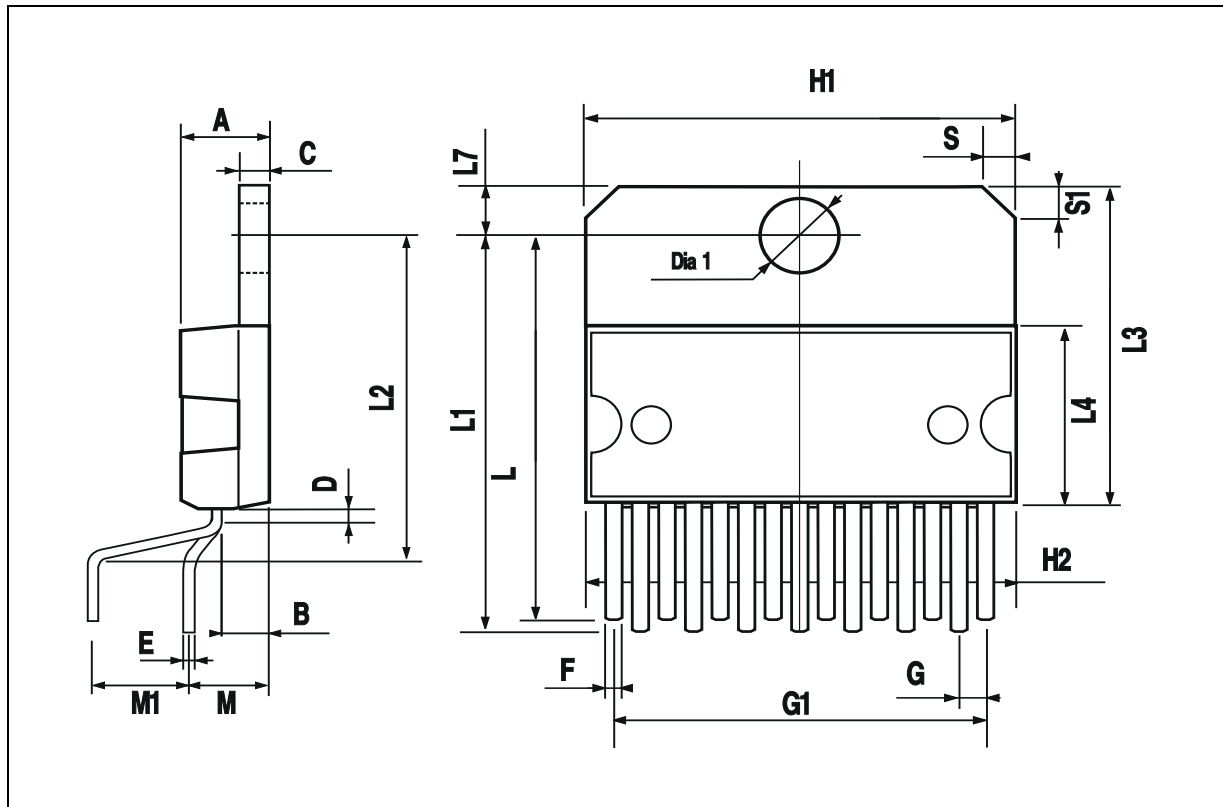

Information furnished is believed to be accurate and reliable. However, STMicroelectronics assumes no responsibility for the consequences of use of such information nor for any infringement of patents or other rights of third parties which may result from its use. No license is granted by implication or otherwise under any patent or patent rights of STMicroelectronics. Specification mentioned in this publication are subject to change without notice. This publication supersedes and replaces all information previously supplied. STMicroelectronics products are not authorized for use as critical components in life support devices or systems without express written approval of STMicroelectronics.

The ST logo is a registered trademark of STMicroelectronics

© 2000 STMicroelectronics – Printed in Italy – All Rights Reserved

STMicroelectronics GROUP OF COMPANIES

Australia - Brazil - China - Finland - France - Germany - Hong Kong - India - Italy - Japan - Malaysia - Malta - Morocco -
Singapore - Spain - Sweden - Switzerland - United Kingdom - U.S.A.

<http://www.st.com>