



Chipsmall Limited consists of a professional team with an average of over 10 year of expertise in the distribution of electronic components. Based in Hongkong, we have already established firm and mutual-benefit business relationships with customers from,Europe,America and south Asia,supplying obsolete and hard-to-find components to meet their specific needs.

With the principle of “Quality Parts,Customers Priority,Honest Operation,and Considerate Service”,our business mainly focus on the distribution of electronic components. Line cards we deal with include Microchip,ALPS,ROHM,Xilinx,Pulse,ON,Everlight and Freescale. Main products comprise IC,Modules,Potentiometer,IC Socket,Relay,Connector.Our parts cover such applications as commercial,industrial, and automotives areas.

We are looking forward to setting up business relationship with you and hope to provide you with the best service and solution. Let us make a better world for our industry!



## Contact us

Tel: +86-755-8981 8866 Fax: +86-755-8427 6832

Email & Skype: info@chipsmall.com Web: www.chipsmall.com

Address: A1208, Overseas Decoration Building, #122 Zhenhua RD., Futian, Shenzhen, China





## 11W+11W AMPLIFIER WITH DC VOLUME CONTROL

- 11+11W OUTPUT POWER  
 $R_L = 8\Omega @THD = 10\% V_{CC} = 28V$
- ST-BY AND MUTE FUNCTIONS
- LOW TURN-ON TURN-OFF POP NOISE
- LINEAR VOLUME CONTROL DC COUPLED WITH POWER OP. AMP.
- NO BOUCHEROT CELL
- NO ST-BY RC INPUT NETWORK
- SINGLE SUPPLY RANGING UP TO 35V
- SHORT CIRCUIT PROTECTION
- THERMAL OVERLOAD PROTECTION
- INTERNALLY FIXED GAIN
- SOFT CLIPPING
- VARIABLE OUTPUT AFTER VOLUME CONTROL CIRCUIT
- MULTIWATT 15 PACKAGE

### MULTIPOWER BI50II TECHNOLOGY

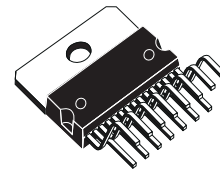

**MULTIWATT15V**

**ORDERING NUMBER: TDA7495**

### DESCRIPTION

The TDA7495 is a stereo 11+11W class AB power amplifier assembled in the Multiwatt 15 package,

specially designed for high quality sound, TV applications.

Features of the TDA7495 include linear volume control, Stand-by and mute functions.

### BLOCK AND APPLICATION DIAGRAM

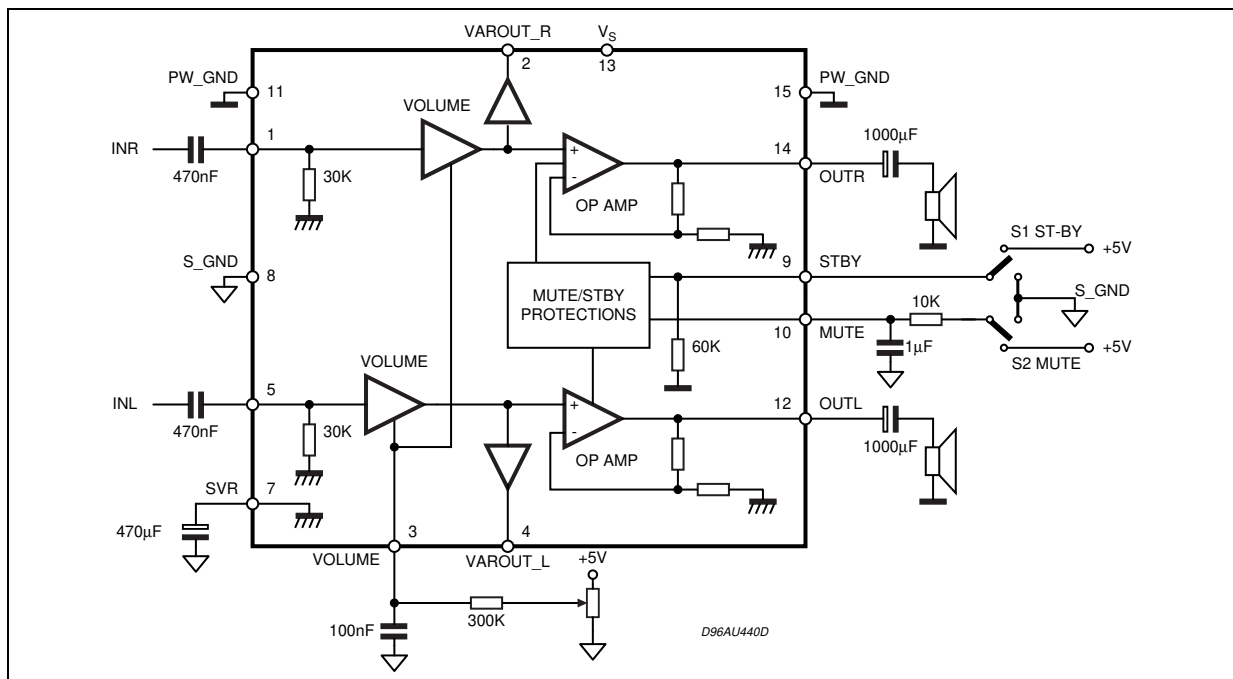

## TDA7495

### ABSOLUTE MAXIMUM RATINGS

Symbol	Parameter	Value	Unit
V <sub>S</sub>	DC Supply Voltage	35	V
V <sub>IN</sub>	Maximum Input Voltage	8	V <sub>pp</sub>
P <sub>tot</sub>	Total Power Dissipation (T <sub>amb</sub> = 70°C)	20	W
T <sub>amb</sub>	Ambient Operating Temperature <sup>(1)</sup>	-20 to 85	°C
T <sub>stg</sub> , T <sub>j</sub>	Storage and Junction Temperature	-40 to 150	°C
V <sub>3</sub>	Volume CTRL DC voltage	7	V

(1) Operation between -20 to 85 °C guaranteed by correlation with 0 to 70°C.

### PIN CONNECTION (Top view)

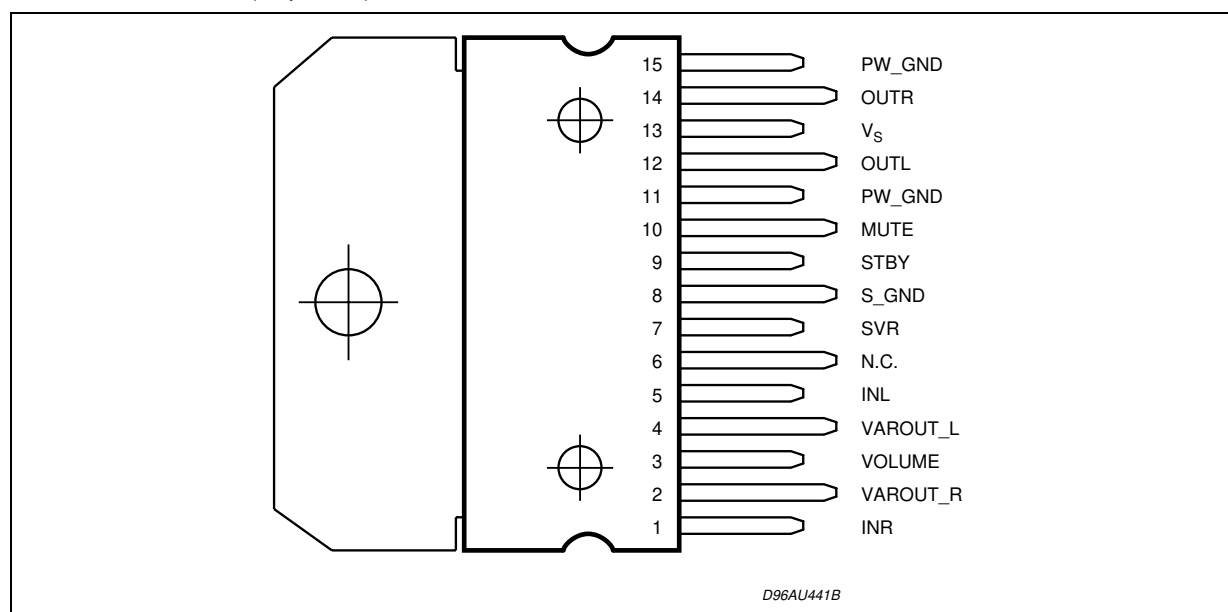

### THERMAL DATA

Symbol	Parameter	Value	Unit
R <sub>th j-case</sub>	Thermal Resistance Junction-case	Typ. = 2    Max. = 2.8	°C/W
R <sub>th j-amb</sub>	Thermal Resistance Junction-ambient	max    35	°C/W

**ELECTRICAL CHARACTERISTICS** (Refer to the test circuit  $V_S = 20V$ ;  $R_L = 8\Omega$ ,  $R_g = 50\Omega$ ,  $T_{amb} = 25^\circ C$ ).

Symbol	Parameter	Test Condition	Min.	Typ.	Max.	Unit
$V_S$	Supply Voltage Range		11		35	V
$I_q$	Total Quiescent Current			70	100	mA
DCVOS	Output DC Offset Referred to SVR Potential	No Input Signal	-650		650	mV
$V_O$	Quiescent Output Voltage			10		V
$P_O$	Output Power	THD = 10%; $R_L = 8\Omega$ ; $V_S = 28V$	9.5	11		W
		THD = 1%; $R_L = 8\Omega$ ; $V_S = 28V$	7.5	8		W
		THD = 10%; $R_L = 4\Omega$ ; $V_{CC} = 20V$	7	8		W
		THD = 1%; $R_L = 4\Omega$ ; $V_{CC} = 20V$	5	6		W
		THD = 10%; $R_L = 8\Omega$ ; $V_{CC} = 18V$	3.5	3.8		W
		THD = 1%; $R_L = 8\Omega$ ; $V_{CC} = 18V$	2.6	2.9		W
THD	Total Harmonic Distortion	$G_V = 30dB$ ; $P_O = 1W$ ; $f = 1KHz$ ;			0.4	%
$I_{peak}$	Output Peak Current	(internally limited)	1.7	2.4		A
$V_{in}$	Input Signal				2.8	V <sub>rms</sub>
$G_V$	Closed Loop Gain	Vol Ctrl > 4.5V	28.5	30	31.5	dB
$G_{VLine}$	Monitor Out Gain	Vol Ctrl > 4.5V; $Z_{load} > 30K\Omega$	-1.5	0	1.5	dB
$A_{Min} V_{OL}$	Attenuation at Minimum Volume	Vol Ctrl < 0.5V	80			dB
BW				0.6		MHz
$e_N$	Total Output Noise	$f = 20Hz$ to 22KHz Play, max volume		500	800	$\mu V$
		$f = 20Hz$ to 22KHz Play, max attenuation		100	250	$\mu V$
		$f = 20Hz$ to 22KHz Mute		60	150	$\mu V$
SR	Slew Rate		5	8		V/ $\mu s$
$R_i$	Input Resistance		22.5	30		K $\Omega$
$R_{Var Out}$	Variable Output Resistance			30	100	$\Omega$
$R_{load Var Out}$	Variable Output Load		2			K $\Omega$
SVR	Supply Voltage Rejection	$f = 1kHz$ ; max volume $C_{SVR} = 470\mu F$ ; $V_{RIP} = 1V_{rms}$	35	39		dB
		$f = 1kHz$ ; max attenuation $C_{SVR} = 470\mu F$ ; $V_{RIP} = 1V_{rms}$	55	65		dB
$T_M$	Thermal Muting			150		$^\circ C$
$T_s$	Thermal Shut-down			160		$^\circ C$
<b>MUTE STAND-BY &amp; INPUT SELECTION FUNCTIONS</b>						
$V_{ST-BY}$	Stand-by threshold		2.3	2.5	2.7	V
$V_{MUTE}$	Mute Threshold		2.3	2.5	2.7	V
$I_{qST-BY}$	Quiescent Current @ Stand-by			0.6	1	mA
$A_{MUTE}$	Mute Attenuation		50	65		dB
$I_{stbyBIAS}$	Stand-by bias current	Stand by on $V_{ST-BY} = 5V$ $V_{MUTE} = 5V$		80		$\mu A$
		Play or Mute	-20	-5		$\mu A$
$I_{muteBIAS}$	Mute bias current	Mute		1	5	$\mu A$
		Play		0.2	2	$\mu A$

Figure 1a. Application Circuit.

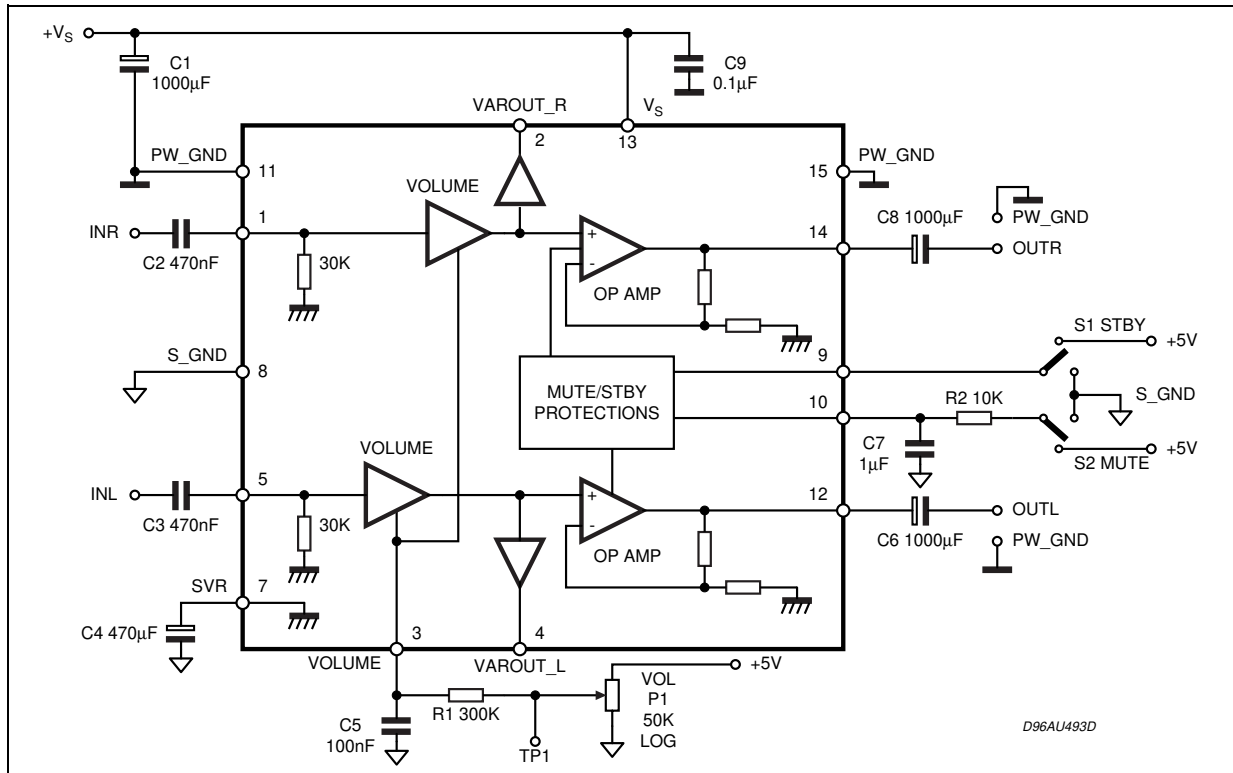
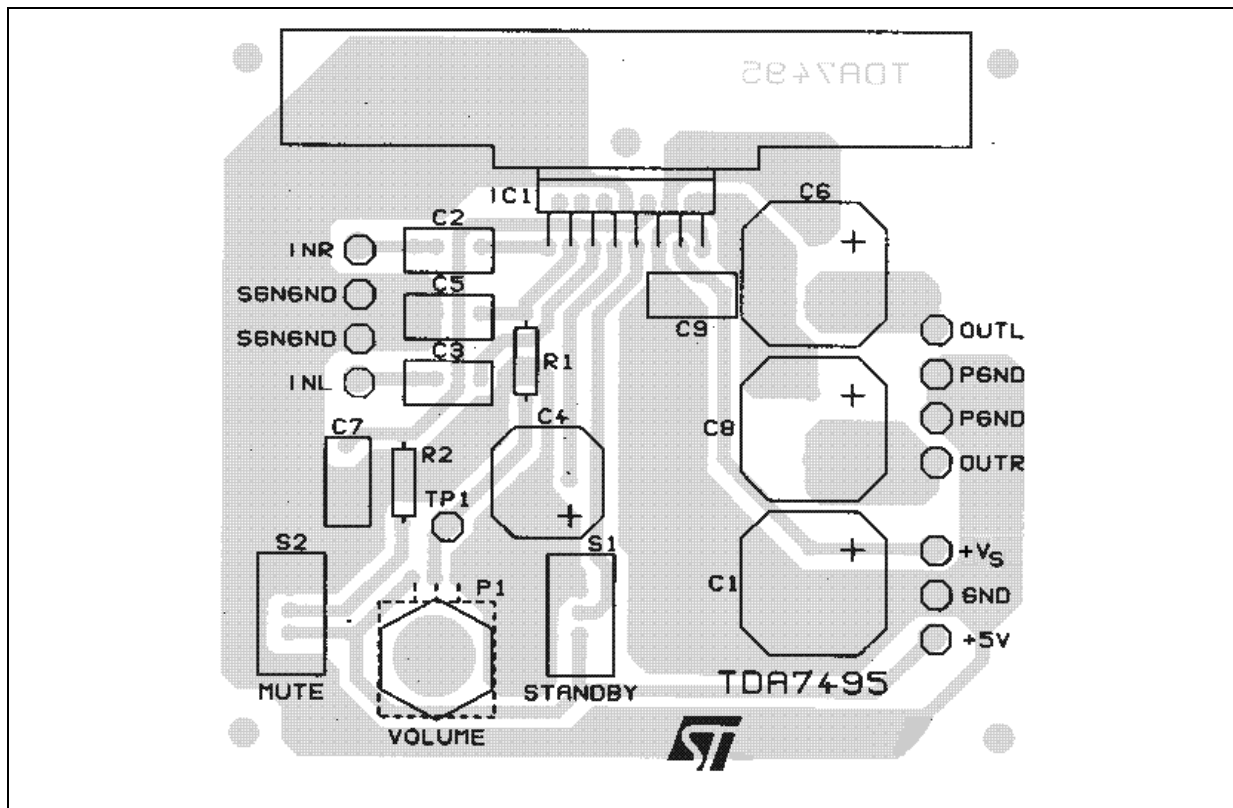

Figure 1b. P.C.B. and Component Layout.



## APPLICATION SUGGESTIONS

The recommended values of the external components are those shown on the application circuit of figure 1a. Different values can be used, the following table can help the designer.

COMPONENT	SUGGESTION VALUE	PURPOSE	LARGER THAN SUGGESTION	SMALLER THAN SUGGESTION
R1	300K	Volume control circuit	Larger volume regulation time	Smaller volume regulation time
R2	10K	Mute time constant	Larger mute on/off time	Smaller mute on/off time
P1	50K	Volume control circuit		
C1	1000 $\mu$ F	Supply voltage bypass		Danger of oscillation
C2	470nF	Input DC decoupling	Lower low frequency cutoff	Higher low frequency cutoff
C3	470nF	Input DC decoupling	Lower low frequency cutoff	Higher low frequency cutoff
C4	470 $\mu$ F	Ripple rejection	Better SVR	Worse SVR
C5	100nF	Volume control time constant	Larger volume regulation time	Smaller volume regulation time
C6	1000 $\mu$ F	Output DC decoupling	Lower low frequency cutoff	Higher low frequency cutoff
C7	1 $\mu$ F	Mute time constant	Larger mute on/off time	Smaller mute on/off time
C8	1000 $\mu$ F	Output DC decoupling	Lower low frequency cutoff	Higher low frequency cutoff
C9	100nF	Supply voltage bypass		Danger of oscillation

## TYPICAL CHARACTERISTICS:

Refer to the application circuit of fig.1A  $T_{amb} = 25^{\circ}\text{C}$ ;  $V_S = 20\text{V}$ ;  $R_L = 8\Omega$ ;  $F = 1\text{KHz}$ ;  $R_S = 50\Omega$ ; unless otherwise specified.

Figure 2. Output Power vs Supply Voltage

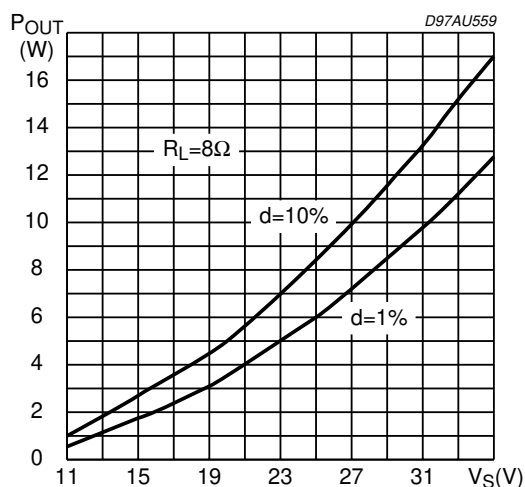

Figure 3. Distortion vs Output Power

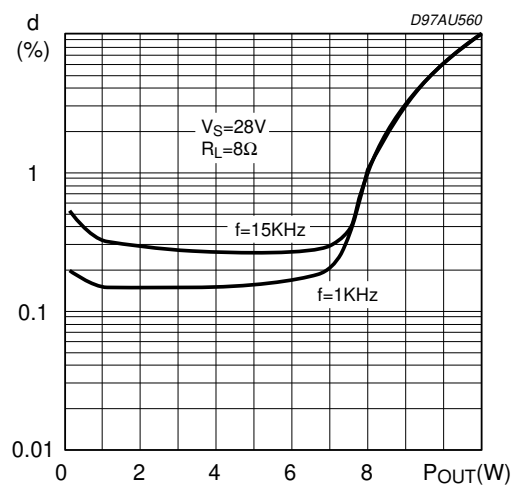

Figure 4. Output Power vs Supply Voltage

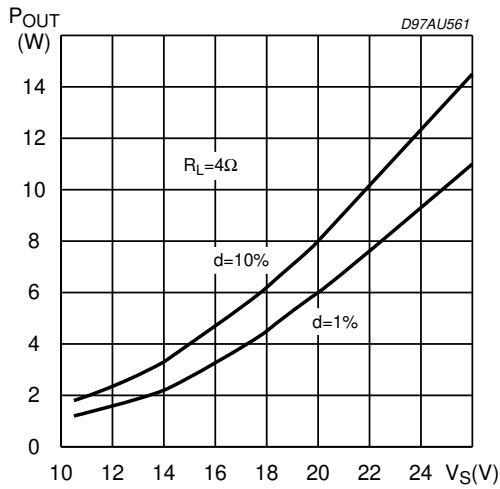

Figure 7. Supply Voltage vs Frequency

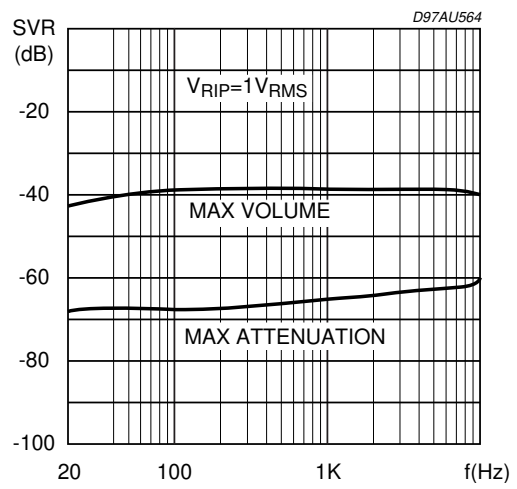

Figure 5. Distortion vs Output Power

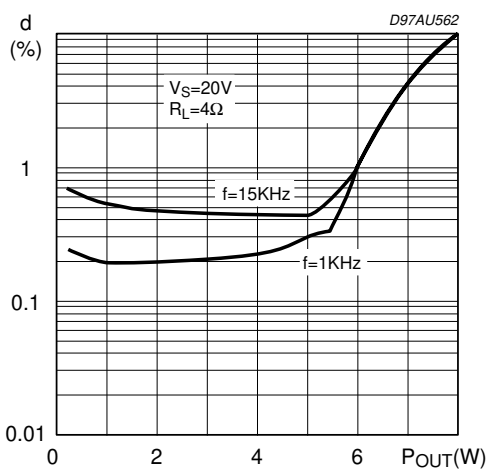

Figure 8. Stand-by Attenuation vs Vpin #9

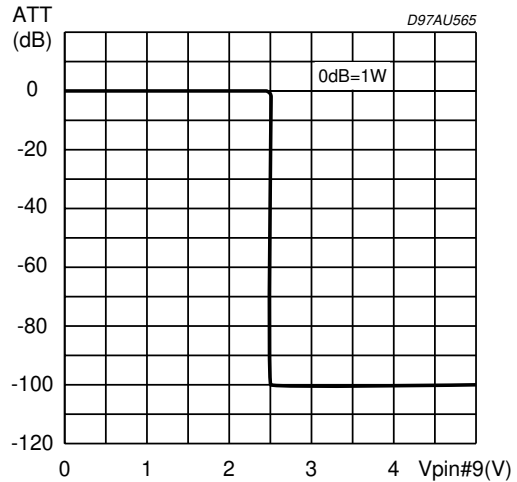

Figure 6. gain vs Volume Control (pin #3)

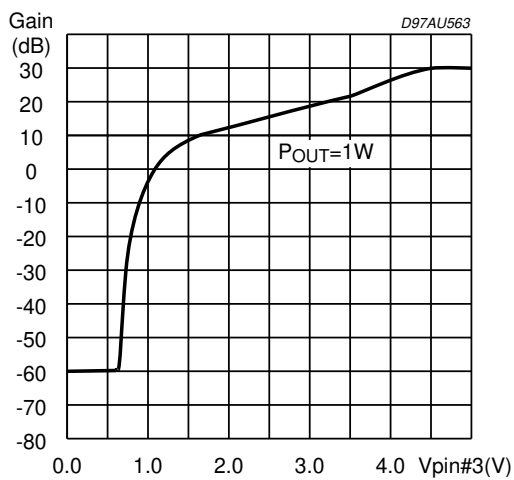

Figure 9. Mute Attenuation vs V pin #10

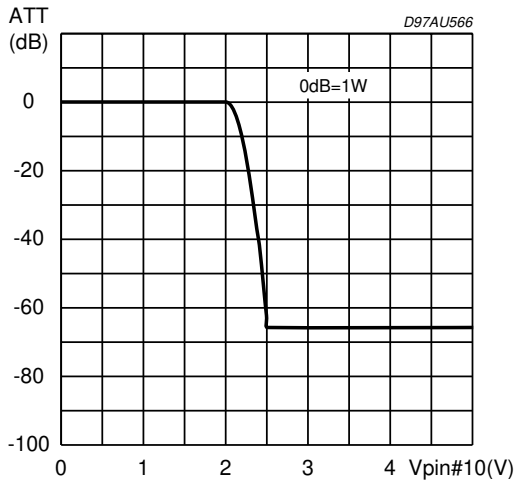

Figure 10. Power dissipation vs Output Power

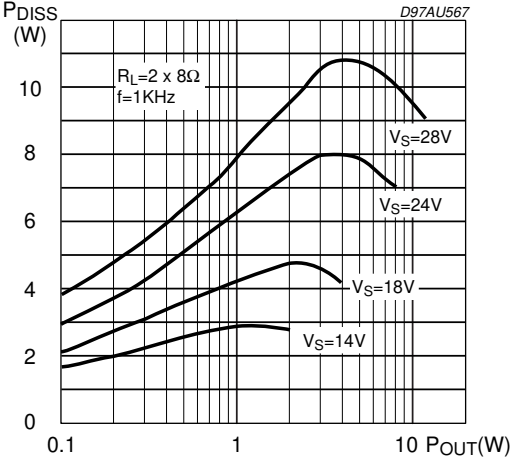
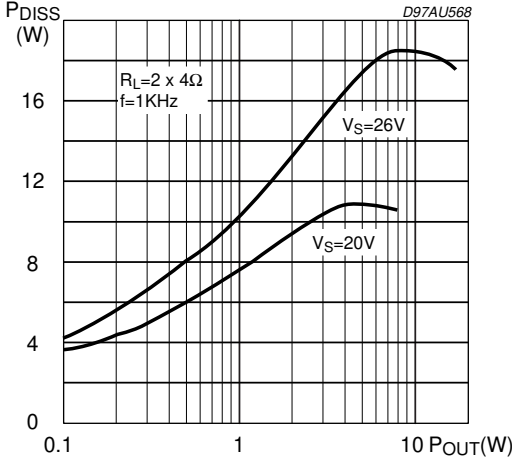

Figure 11. Power Dissipation vs Output Power





**MUTE STAND-BY TRUTH TABLE**

MUTE	ST-BY	OPERATING CONDITION
H	H	STANDBY
L	H	STANDBY
H	L	MUTE
L	L	PLAY

**Turn ON/OFF Sequences (for optimizing the POP performances)**

**A) USING MUTE AND STAND-BY FUNCTIONS**

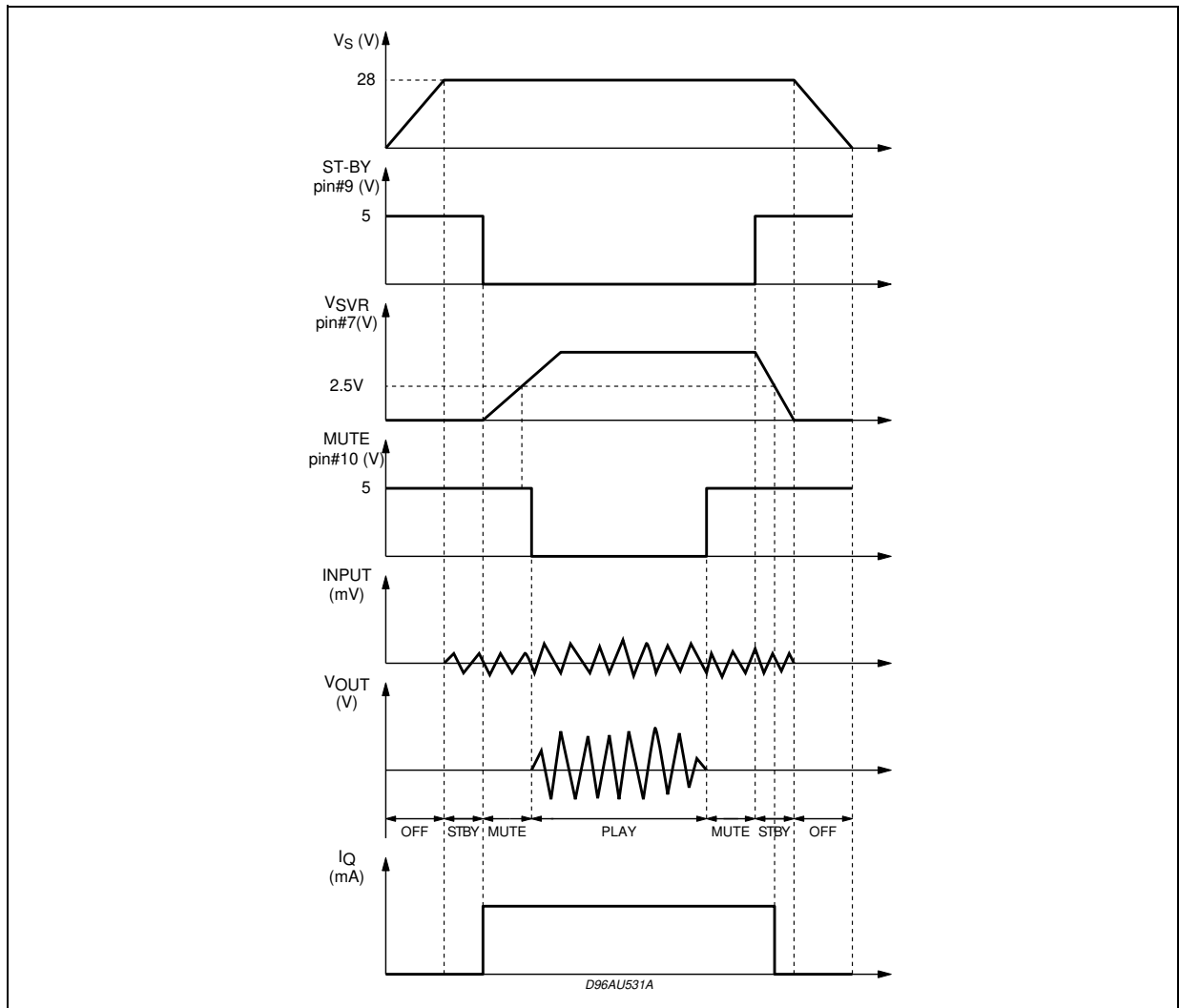

**B) USING ONLY THE MUTE FUNCTION**

To simplify the application, the stand-by pin can be connected directly to Ground.

During the ON/OFF transitions we recommend to respect the following conditions:

- At the turn-on the transition mute to play must be made when the SVR pin is higher than 2.5V
- At the turn-off the TDA7495 must be brought to mute from the play condition when the SVR pin is higher than 2.5V.

Figure 12. PINS: INL, INR

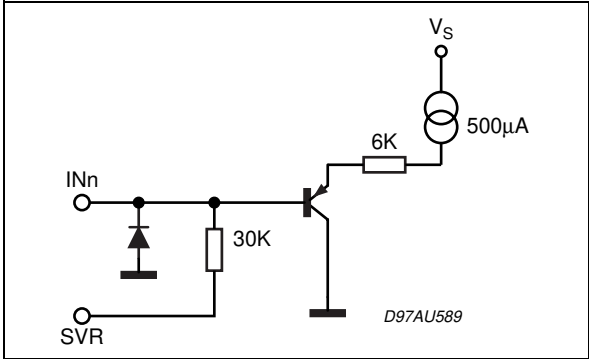

Figure 16. PINS: VAROUT-L, VAROUT-R

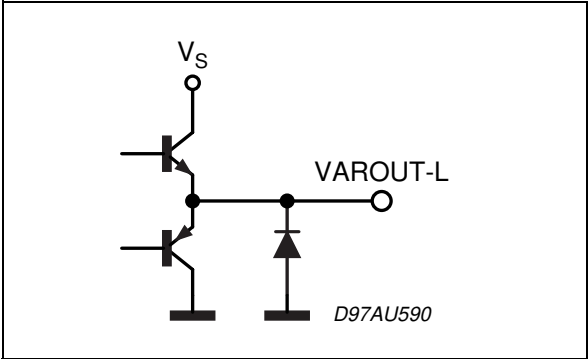

Figure 13. PIN: VOLUME

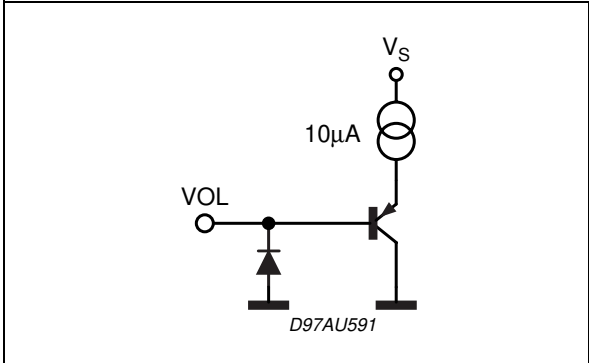

Figure 17. PIN: MUTE

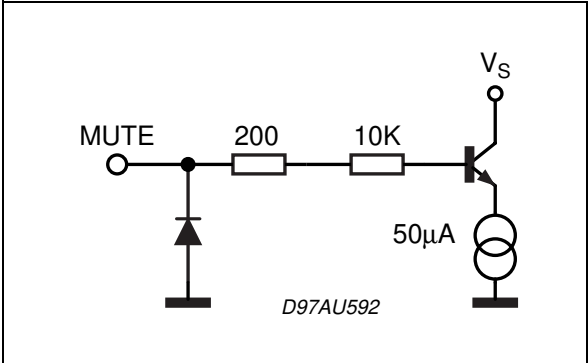

Figure 14. PINS: PW-GND, S-GND

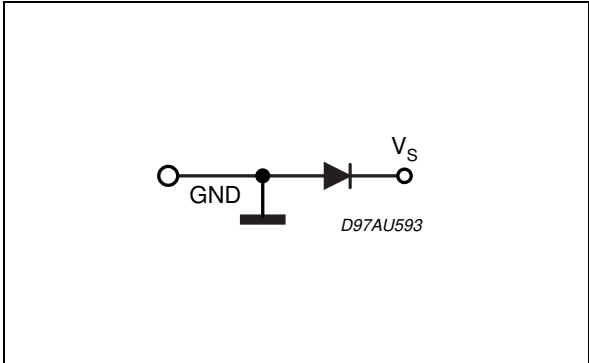

Figure 18. PINS: OUT R, OUT L

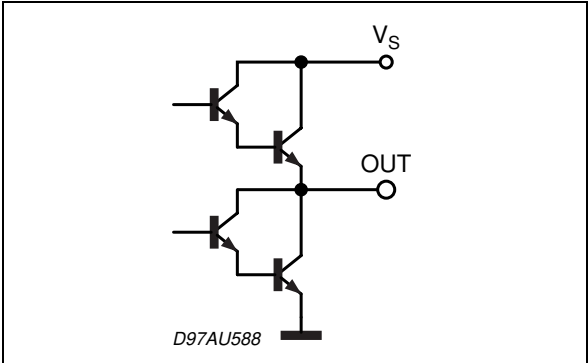

Figure 15. PIN: STBY

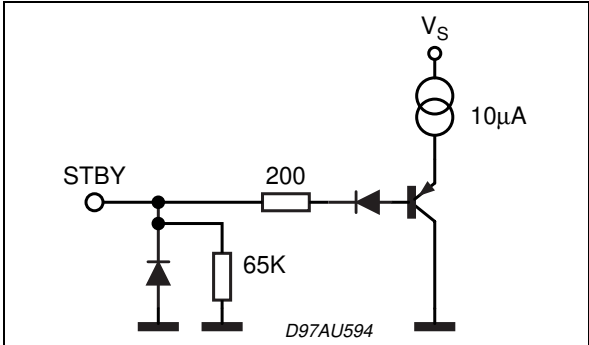
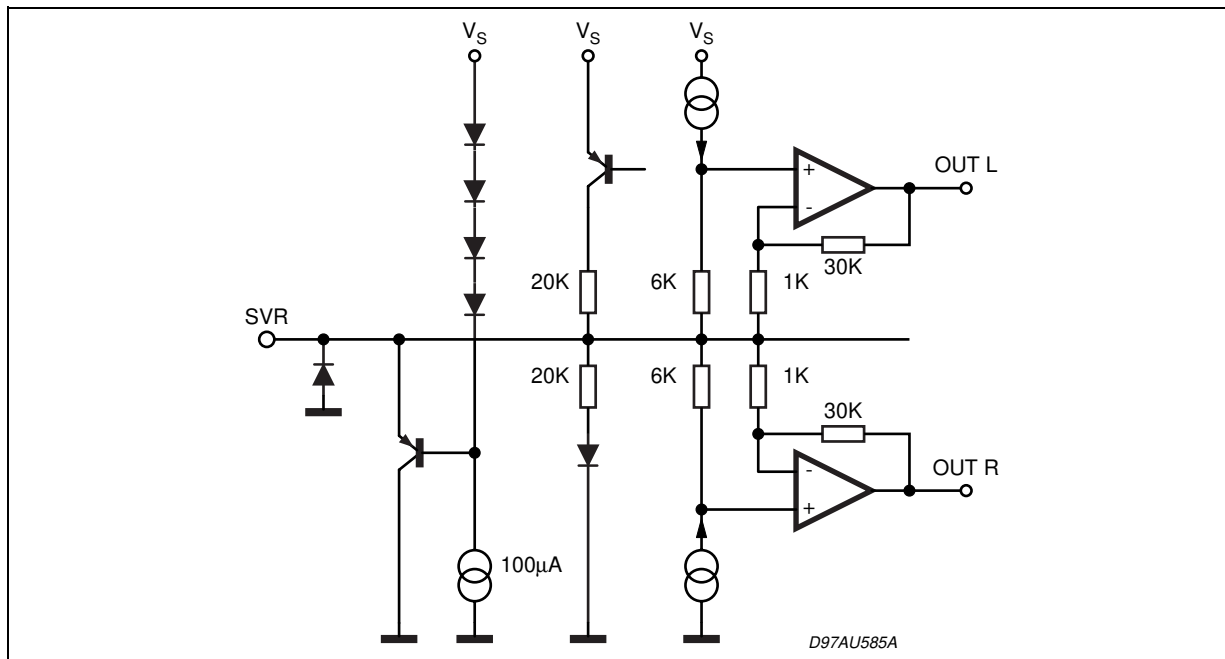
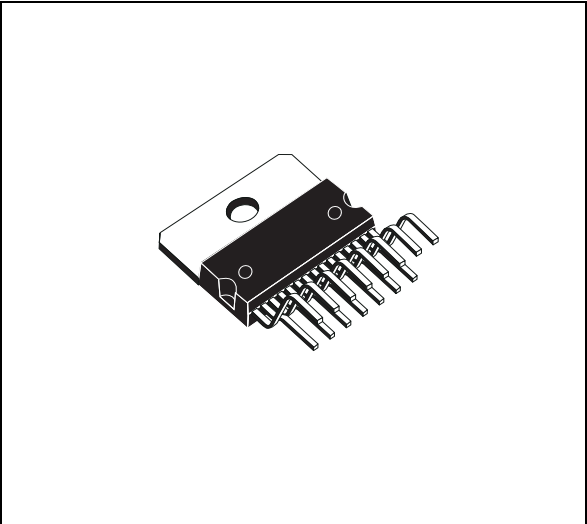

Figure 19. PIN: SVR



DIM.	mm			inch		
	MIN.	TYP.	MAX.	MIN.	TYP.	MAX.
A5						0.197
B			2.65			0.104
C			1.6			0.063
D		1			0.039	
E	0.49		0.55	0.019		0.022
F	0.66		0.75	0.026		0.030
G	1.02	1.27	1.52	0.040	0.050	0.060
G1	17.53	17.78	18.03	0.690	0.700	0.710
H1	19.6			0.772		
H2			20.2			0.795
L	21.9	22.2	22.5	0.862	0.874	0.886
L1	21.7	22.1	22.5	0.854	0.87	0.886
L2	17.65		18.1	0.695		0.713
L3	17.25	17.5	17.75	0.679	0.689	0.699
L4	10.3	10.7	10.9	0.406	0.421	0.429
L7	2.65		2.9	0.104		0.114
M	4.25	4.55	4.85	0.167	0.179	0.191
M1	4.73	5.08	5.43	0.186	0.200	0.214
S	1.9		2.6	0.075		0.102
S1	1.9		2.6	0.075		0.102
Dia1	3.65		3.85	0.144		0.152

**OUTLINE AND MECHANICAL DATA**



**Multiwatt15 (Vertical)**

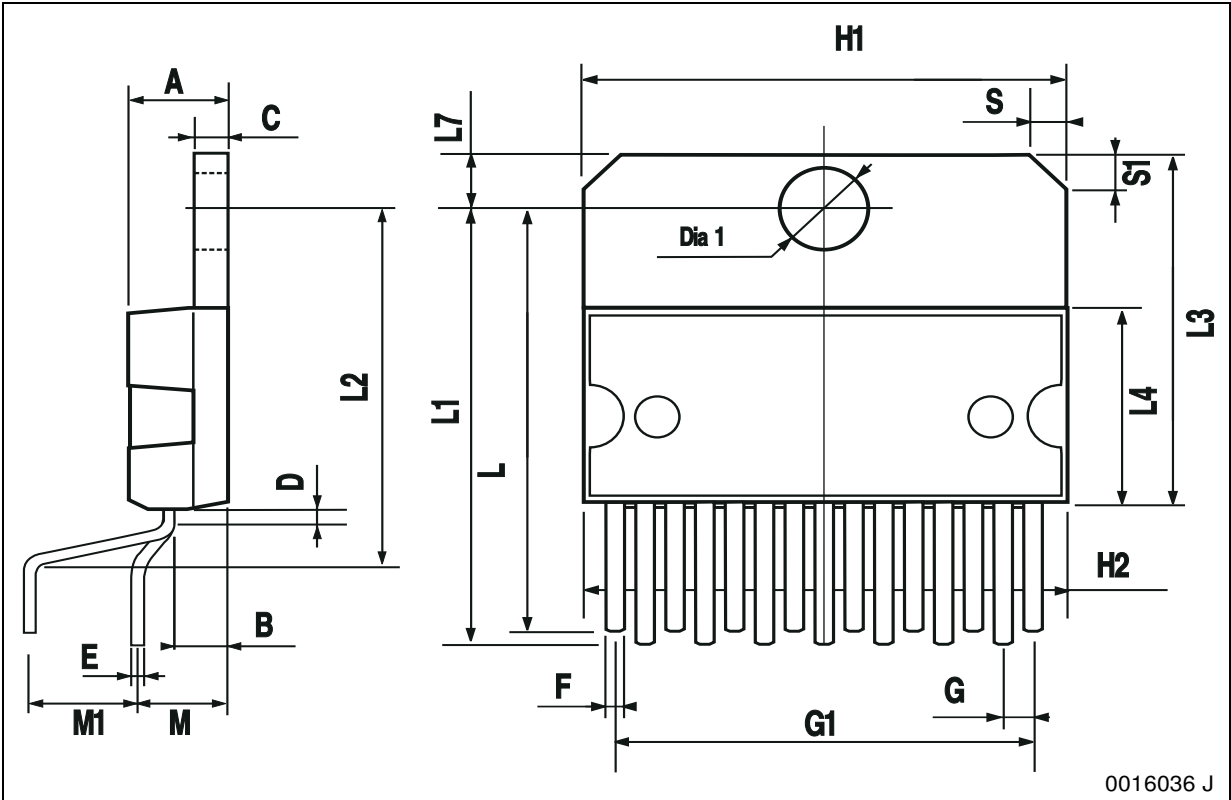

Information furnished is believed to be accurate and reliable. However, STMicroelectronics assumes no responsibility for the consequences of use of such information nor for any infringement of patents or other rights of third parties which may result from its use. No license is granted by implication or otherwise under any patent or patent rights of STMicroelectronics. Specifications mentioned in this publication are subject to change without notice. This publication supersedes and replaces all information previously supplied. STMicroelectronics products are not authorized for use as critical components in life support devices or systems without express written approval of STMicroelectronics.

The ST logo is a registered trademark of STMicroelectronics.  
All other names are the property of their respective owners

© 2003 STMicroelectronics - All rights reserved

**STMicroelectronics GROUP OF COMPANIES**

Australia - Belgium - Brazil - Canada - China - Czech Republic - Finland - France - Germany - Hong Kong - India - Israel - Italy - Japan -  
Malaysia - Malta - Morocco - Singapore - Spain - Sweden - Switzerland - United Kingdom - United States

[www.st.com](http://www.st.com)