



Chipsmall Limited consists of a professional team with an average of over 10 year of expertise in the distribution of electronic components. Based in Hongkong, we have already established firm and mutual-benefit business relationships with customers from,Europe,America and south Asia,supplying obsolete and hard-to-find components to meet their specific needs.

With the principle of “Quality Parts,Customers Priority,Honest Operation,and Considerate Service”,our business mainly focus on the distribution of electronic components. Line cards we deal with include Microchip,ALPS,ROHM,Xilinx,Pulse,ON,Everlight and Freescale. Main products comprise IC,Modules,Potentiometer,IC Socket,Relay,Connector.Our parts cover such applications as commercial,industrial, and automotives areas.

We are looking forward to setting up business relationship with you and hope to provide you with the best service and solution. Let us make a better world for our industry!



Contact us

Tel: +86-755-8981 8866 Fax: +86-755-8427 6832

Email & Skype: info@chipsmall.com Web: www.chipsmall.com

Address: A1208, Overseas Decoration Building, #122 Zhenhua RD., Futian, Shenzhen, China





TDA7495S

11W +11W AMPLIFIER

- 11+11W OUTPUT POWER
- $R_L = 8 \Omega$ @THD = 10% $V_{CC} = 28V$
- ST-BY AND MUTE FUNCTIONS
- LOW TURN-ON TURN-OFF POP NOISE
- NO BOUCHEROT CELL
- NO ST-BY RC INPUT NETWORK
- SINGLE SUPPLY RANGING UP TO 35V
- SHORT CIRCUIT PROTECTION
- THERMAL OVERLOAD PROTECTION
- INTERNALLY FIXED GAIN
- SOFT CLIPPING
- MULTIWATT 15 PACKAGE

MULTIPOWER BI50II TECHNOLOGY

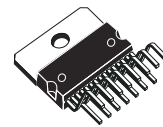

Multiwatt 15
ORDERING NUMBER: TDA7495S

DESCRIPTION

The TDA7495S is a stereo 11+11W class AB power amplifier assembled in the @ Multiwatt 15 package, specially designed for high quality sound, TV applications.

Features of the TDA7495S include linear Stand-by and mute functions.

BLOCK AND APPLICATION CIRCUIT

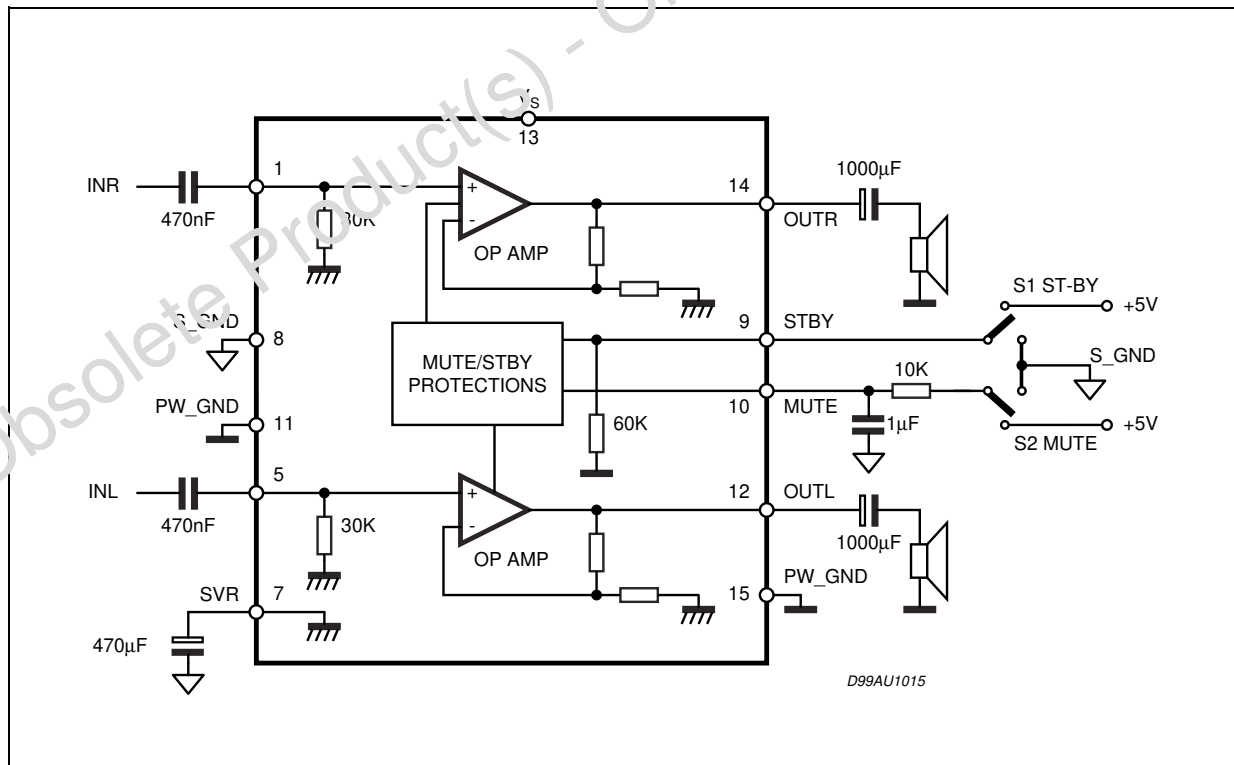

TDA7495S

ABSOLUTE MAXIMUM RATINGS

Symbol	Parameter	Value	Unit
V _S	DC Supply Voltage	40	V
V _{IN}	Maximum Input Voltage	8	V _{pp}
P _{tot}	Total Power Dissipation (T _{amb} = 70°C)	20	W
T _{amb}	Ambient Operating Temperature (1)	-20 to 85	°C
T _{stg} , T _J	Storage and Junction Temperature	-40 to 150	°C

(1) Operation between -20 to 85 °C guaranteed by correlation with 0 to 70°C.

PIN CONNECTION (top view)

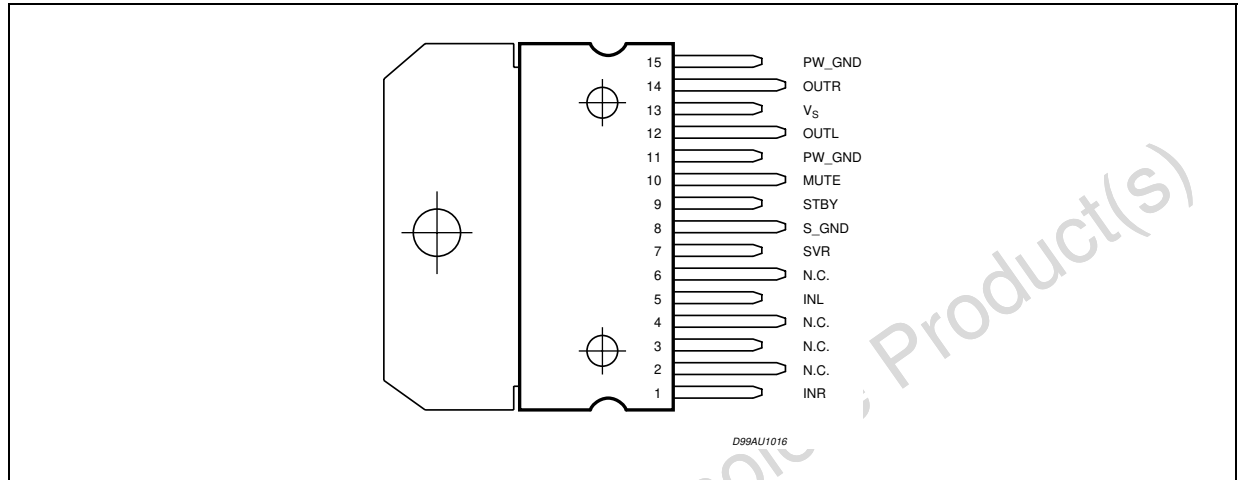

THERMAL DATA

Symbol	Parameter	Value	Unit
R _{th j-case}	Thermal Resistance junction-case	Typ. = 2; Max. = 2.8	°C/W
R _{th j-amb}	Thermal Resistance junction-ambient	max 35	°C/W

ELECTRICAL CHARACTERISTICS (Refer to the test circuit V_s = 20V; R_L = 8Ω, R_g = 50Ω, T_{amb} = 25°C)

Symbol	Parameter	Test Condition	Min.	Typ.	Max.	Unit
V _S	Supply Voltage Range		11		35	V
I _q	Total Quiescent Current			70	100	mA
DCV _{os}	Output DC Offset Referred to SVR Potential	No Input Signal	-750		750	mV
V _O	Quiescent Output Voltage		8.5	10	11.5	V
P _O	Output Power	THD = 10%; R _L = 8Ω; V _S = 28V	9.5	11		W
		THD = 1%; R _L = 8Ω; V _S = 28V	7.5	8.8		W
		THD = 10%; R _L = 4Ω; V _S = 20V	7	8.7		W
		THD = 1%; R _L = 4Ω; V _S = 20V	5	6.8		W
		THD = 10%; R _L = 8Ω; V _S = 18V	3.5	4		W
		THD = 1%; R _L = 8Ω; V _S = 18V	2.2	3.2		W

ELECTRICAL CHARACTERISTICS (Refer to the test circuit $V_s = 20V$; $R_L = 8\Omega$, $R_g = 50\Omega$, $T_{amb} = 25^\circ C$)

Symbol	Parameter	Test Condition	Min.	Typ.	Max.	Unit
THD	Total Harmonic Distortion	$G_v = 30dB$; $P_O = 1W$; $f = 1KHz$			0.4	%
I_{peak}	Output Peak Current	(internally limited)	1.7	2.4		A
V_{IN}	Input Signal				2.8	Vrms
G_v	Closed Loop Gain		28.5	30	31.5	dB
BW				0.6		MHz
e_N	Total Output Noise	$f = 20Hz$ to $22KHz$ PLAY,		500	800	μV
		$f = 20Hz$ to $22KHz$ MUTE		60	150	μV
SR	Slew Rate		5	8		V/ μs
R_i	Input Resistance		22.5	30		K Ω
SVR	Supply Voltage Rejection	$f = 1KHz$; max volume $C_{SVR} = 470\mu F$; $V_{RIP} = 1V_{rms}$	35	39		dB
		$f = 1KHz$; max attenuation $C_{SVR} = 470\mu F$; $V_{RIP} = 1V_{rms}$	55	65		dB
T_M	Thermal Muting			150		$^\circ C$
T_S	Thermal Shut-down			160		$^\circ C$
MUTE & INPUT SELECTION FUNCTIONS						
V_{ST-BY}	Stand-by ON Threshold		2.3	2.5	2.7	V
V_{MUTE}	Mute Threshold		2.3	2.5	2.7	V
I_{qST-BY}	Quiescent Current @ Stand-by			0.6	1	mA
A_{MUTE}	Mute Threshold		50	65		V
$I_{stbyBIAS}$	Stand-by bias current	Stand by ON: $V_{ST-BY} = 5V$; $V_{mute} = 5V$		80		μA
		Play or Mute	-20	-5		μA
$I_{muteBIAS}$	Mute Bias Current	Mute		1	5	μA
		Play		0.2	2	μA

TDA7495S

Figure 1. Application circuit

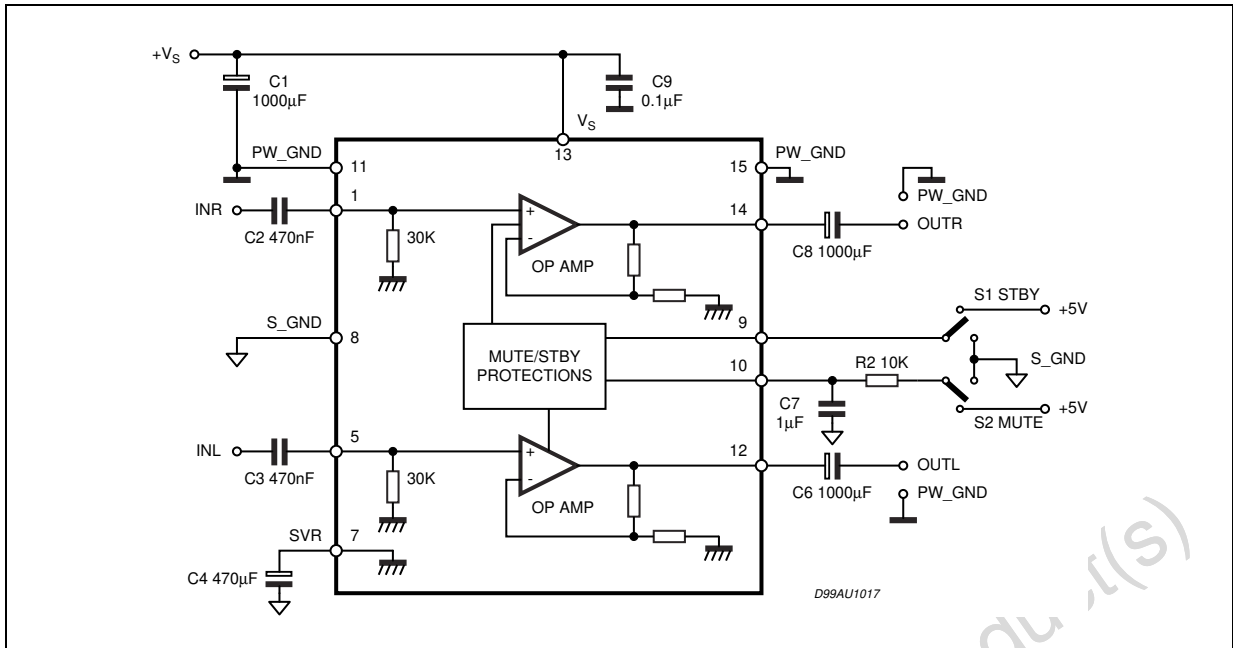
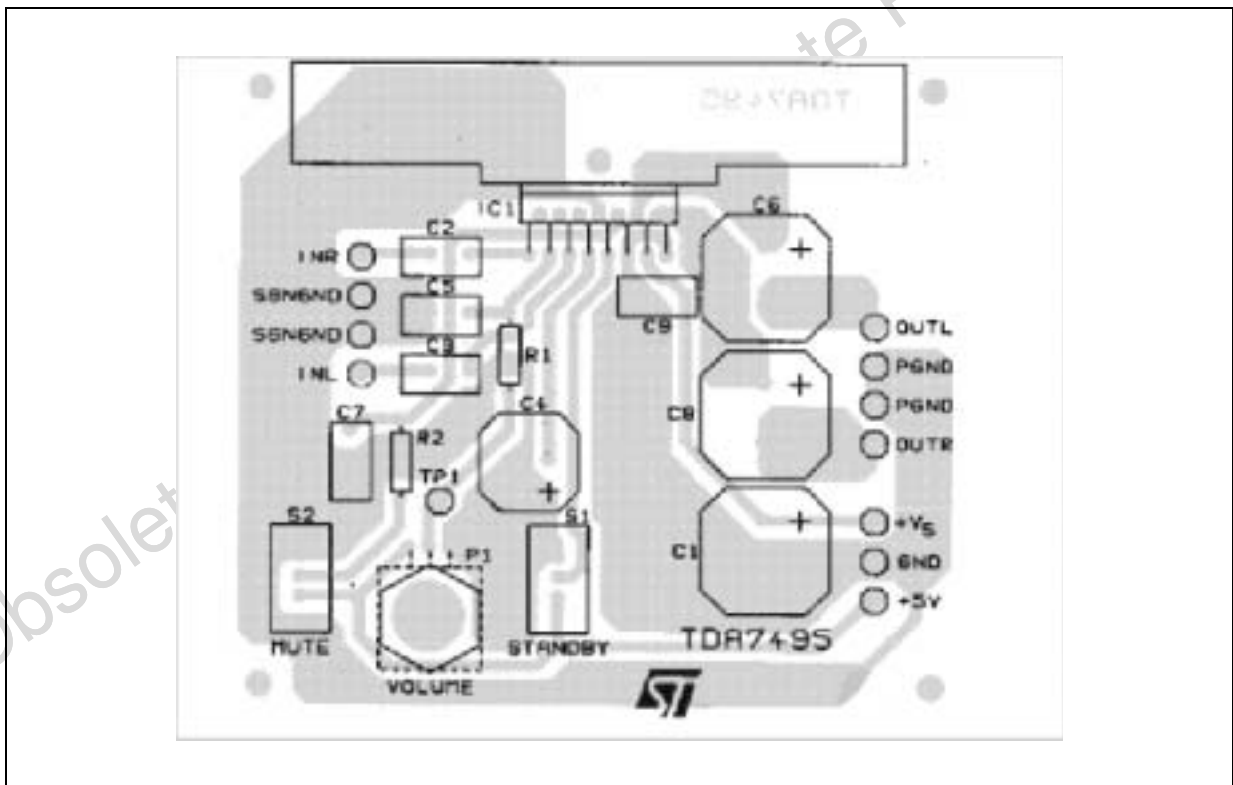

Figure 2. PCB and Component Layout



APPLICATION SUGGESTIONS

The recommended values of the external components are those shown on the application circuit of figure 1. Different values can be used, the following table can help the designer.

COMPONENT	SUGGESTION VALUE	PURPOSE	LARGER THAN SUGGESTION	SMALLER THAN SUGGESTION
R2	10K	Mute time constant	Larger mute on/off time	Smaller mute on/off time
C1	1000 μ F	Supply voltage bypass		Danger of oscillation
C2	470nF	Input DC decoupling	Lower low frequency cutoff	Higher low frequency cutoff
C3	470nF	Input DC decoupling	Lower low frequency cutoff	Higher low frequency cutoff
C4	470 μ F	Ripple rejection	Better SVR	Worse SVR
C6	1000 μ F	Output DC decoupling	Lower low frequency cutoff	Higher low frequency cutoff
C7	1 μ F	Mute time constant	Larger mute on/off time	Smaller mute on/off time
C8	1000 μ F	Output DC decoupling	Lower low frequency cutoff	Higher low frequency cutoff
C9	100nF	Supply voltage bypass		Danger of oscillation

TYPICAL CHARACTERISTICS:

Refer to the application circuit of fig.1A $T_{amb} = 25^{\circ}\text{C}$; $V_S = 20\text{V}$; $R_L = 8\Omega$; $f = 1\text{KHz}$; $R_S = 50\Omega$; unless otherwise specified.

Figure 3. Output Power vs Supply Voltage

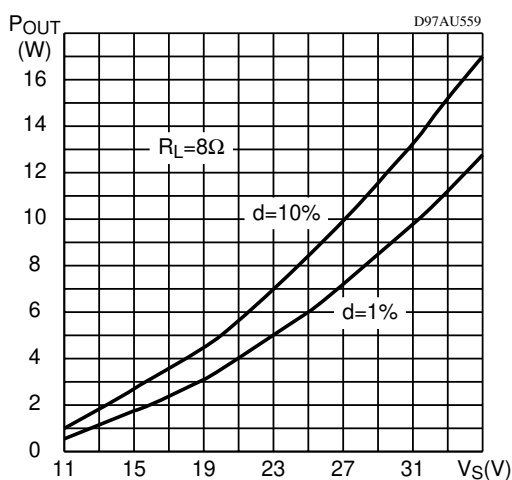

Figure 4. Distortion vs Output Power

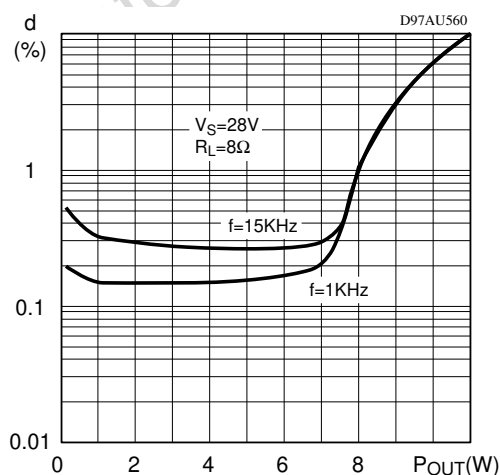

Figure 5. Output Power vs Supply Voltage

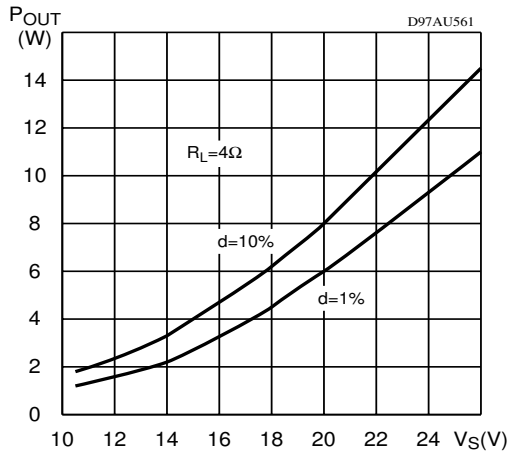

Figure 8. Mute Attenuation vs V pin #10

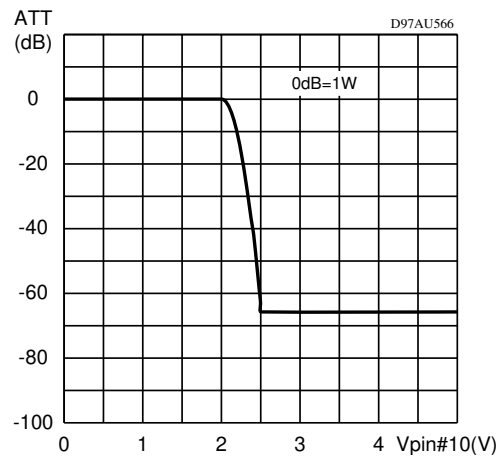

Figure 6. Distortion vs Output Power

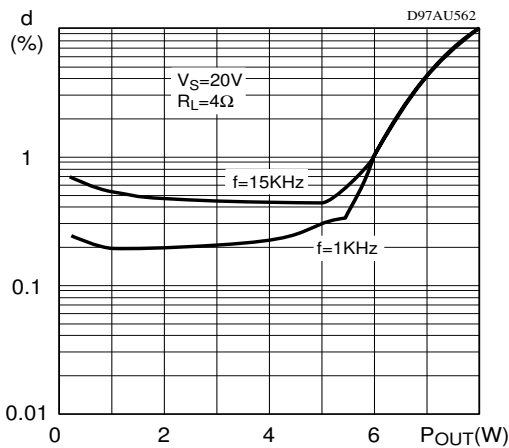

Figure 9. Power dissipation vs Output Power

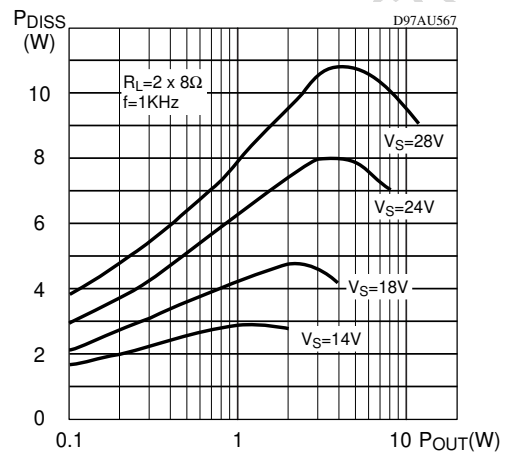

Figure 7. Stand-by Attenuation vs Vpin #9

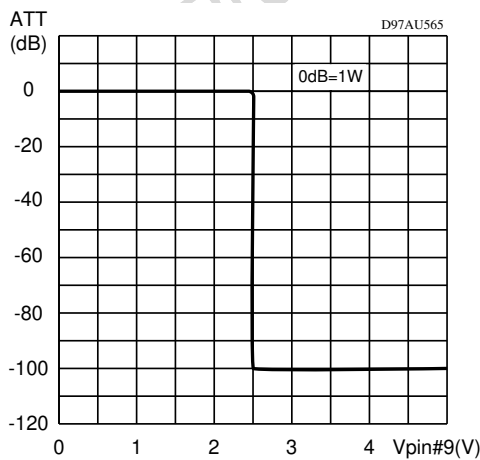
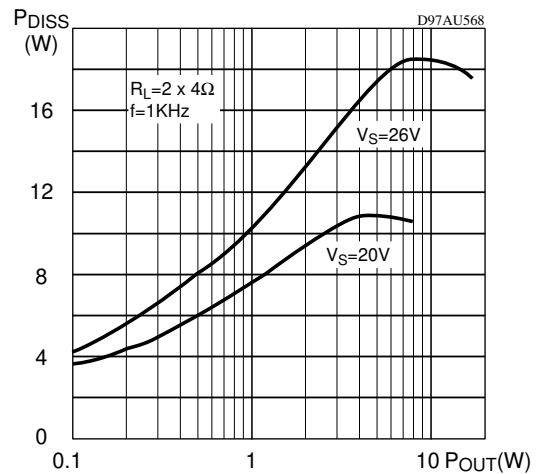
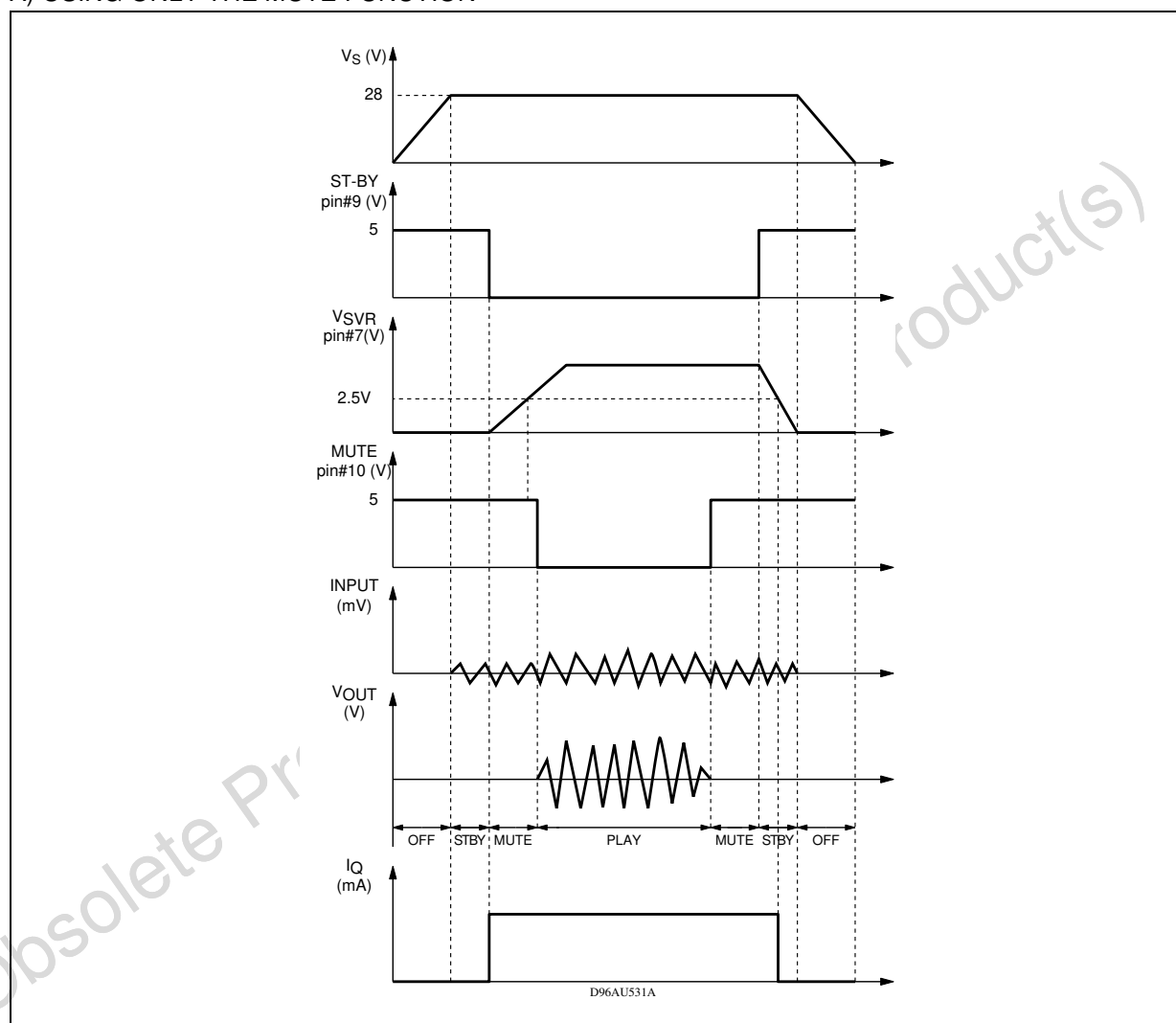

Figure 10. Power dissipation vs Output Power



MUTE STAND-BY TRUTH TABLE

MUTE	St-BY	OPERATING CONDITION
H	H	STAND-BY
L	H	STAND-BY
H	L	MUTE
L	L	PLAY

Turn ON/OFF Sequences (for optimizing the POP performances)**A) USING ONLY THE MUTE FUNCTION****B) USING ONLY THE MUTE FUNCTION**

To simplify the application, the stand-by pin can be connected directly to Ground. During the ON/OFF transitions it is recommended to respect the following conditions:

- At the turn-on the transition mute to play must be made when the SVR pin is higher than 2.5V
- At the turn-off the TDA7495S must be brought to mute from the play condition when the SVR pin is higher than 2.5V.

Figure 11. PINS: INL, INR

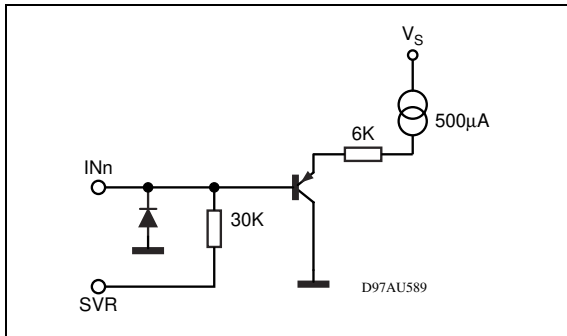

Figure 12. PINS: PW-GND, S-GND

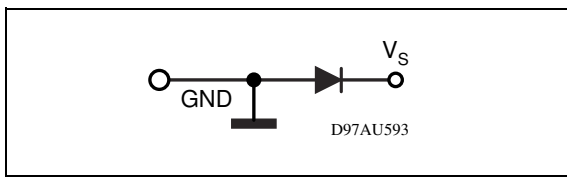

Figure 13. PIN: STBY

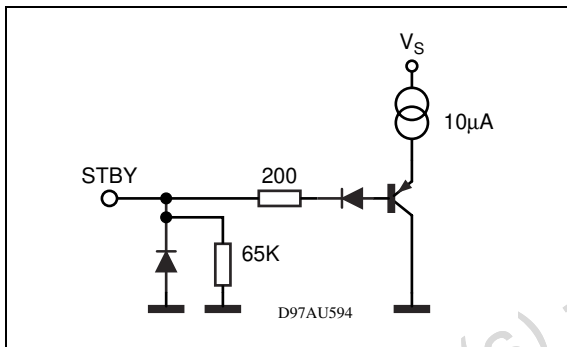

Figure 16. PIN: SVR

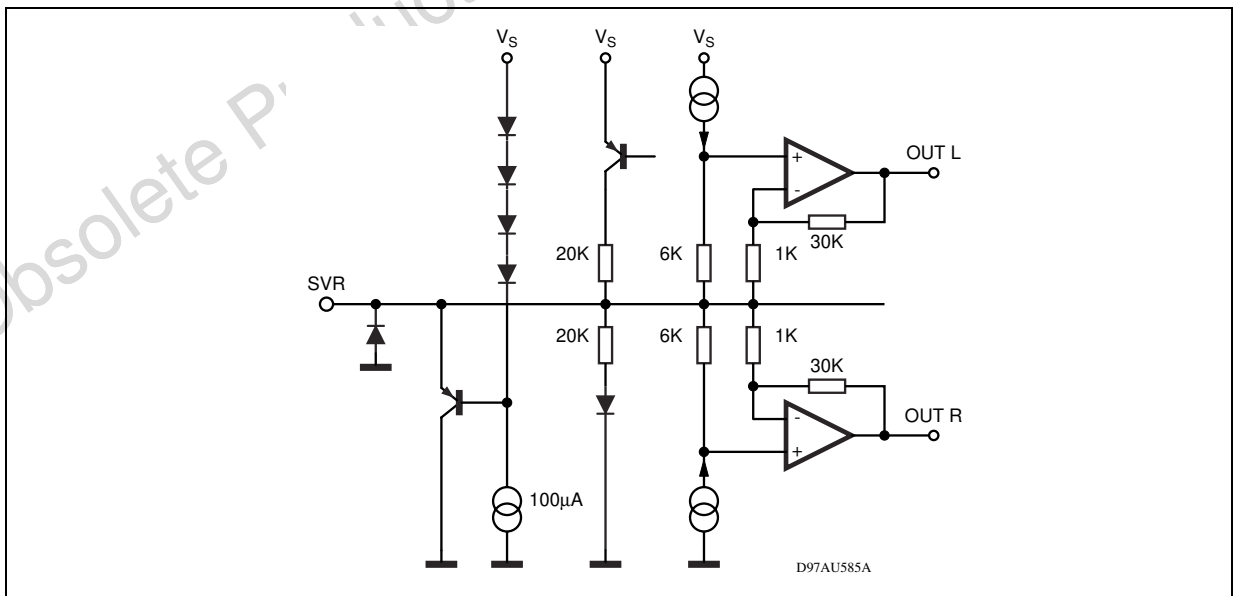

Figure 14. PIN :MUTE

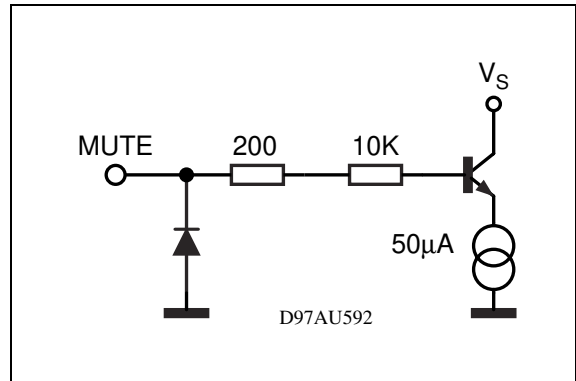
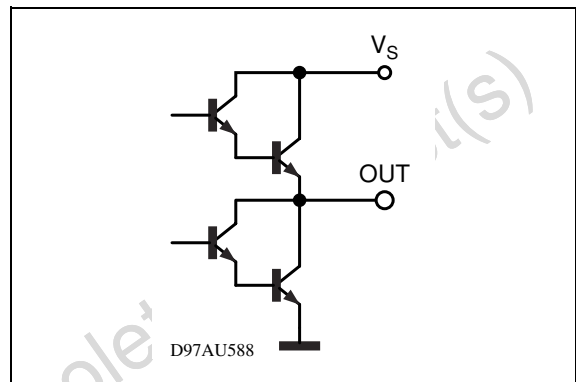
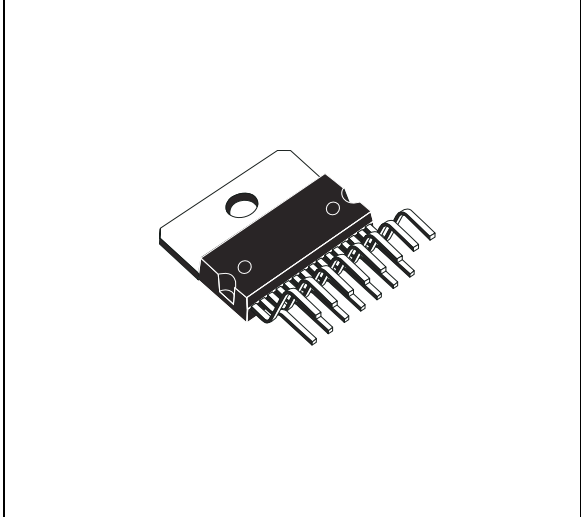

Figure 15. PINS: OUT R, OUT L



DIM.	mm			inch		
	MIN.	TYP.	MAX.	MIN.	TYP.	MAX.
A5						0.197
B			2.65			0.104
C			1.6			0.063
D		1			0.039	
E	0.49		0.55	0.019		0.022
F	0.66		0.75	0.026		0.030
G	1.02	1.27	1.52	0.040	0.050	0.060
G1	17.53	17.78	18.03	0.690	0.700	0.710
H1	19.6			0.772		
H2			20.2			0.795
L	21.9	22.2	22.5	0.862	0.874	0.886
L1	21.7	22.1	22.5	0.854	0.87	0.886
L2	17.65		18.1	0.695		0.713
L3	17.25	17.5	17.75	0.679	0.689	0.699
L4	10.3	10.7	10.9	0.406	0.421	0.429
L7	2.65		2.9	0.104		0.114
M	4.25	4.55	4.85	0.167	0.179	0.191
M1	4.73	5.08	5.43	0.186	0.200	0.214
S	1.9		2.6	0.075		0.102
S1	1.9		2.6	0.075		0.102
Dia1	3.65		3.85	0.144		0.152

OUTLINE AND MECHANICAL DATA



Multiwatt15 (Vertical)

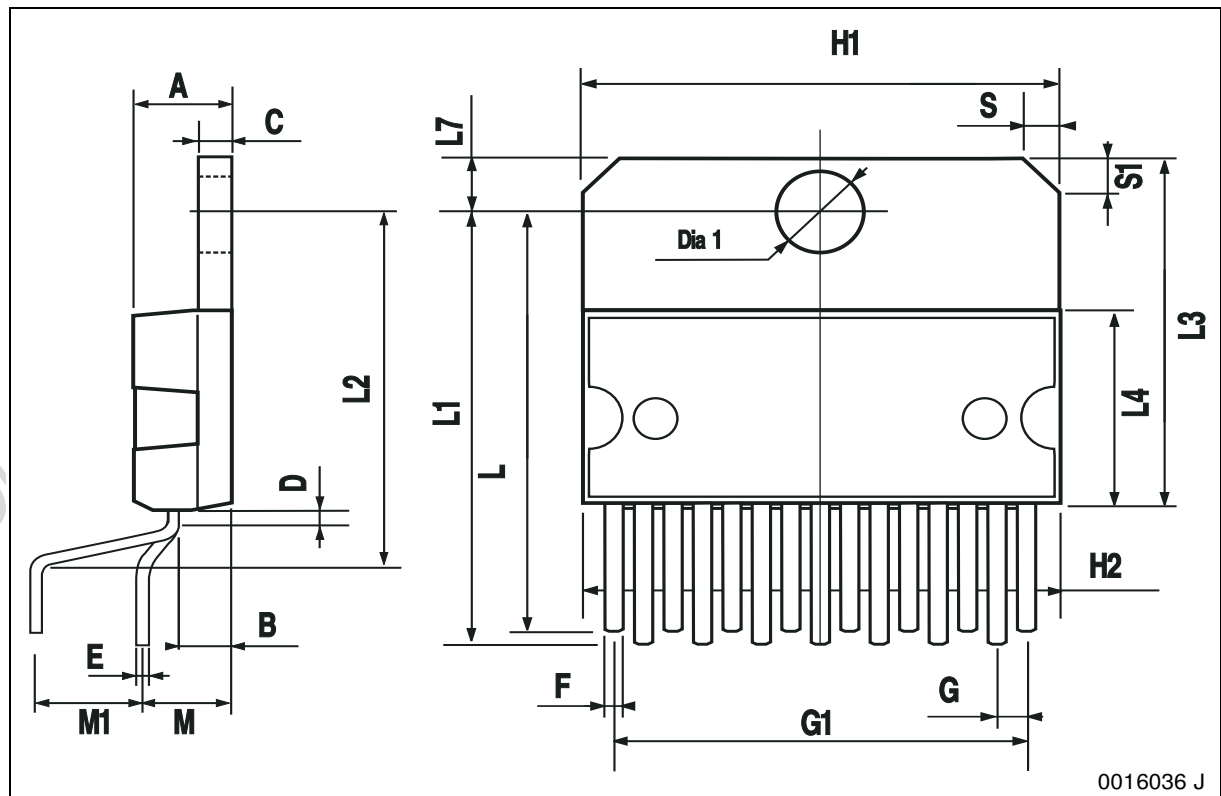

0016036 J

Information furnished is believed to be accurate and reliable. However, STMicroelectronics assumes no responsibility for the consequences of use of such information nor for any infringement of patents or other rights of third parties which may result from its use. No license is granted by implication or otherwise under any patent or patent rights of STMicroelectronics. Specifications mentioned in this publication are subject to change without notice. This publication supersedes and replaces all information previously supplied. STMicroelectronics products are not authorized for use as critical components in life support devices or systems without express written approval of STMicroelectronics.

The ST logo is a registered trademark of STMicroelectronics.
All other names are the property of their respective owners

© 2004 STMicroelectronics - All rights reserved

STMicroelectronics GROUP OF COMPANIES

Australia - Belgium - Brazil - Canada - China - Czech Republic - Finland - France - Germany - Hong Kong - India - Israel - Italy - Japan -
Malaysia - Malta - Morocco - Singapore - Spain - Sweden - Switzerland - United Kingdom - United States

www.st.com