



Chipsmall Limited consists of a professional team with an average of over 10 year of expertise in the distribution of electronic components. Based in Hongkong, we have already established firm and mutual-benefit business relationships with customers from,Europe,America and south Asia,supplying obsolete and hard-to-find components to meet their specific needs.

With the principle of "Quality Parts,Customers Priority,Honest Operation,and Considerate Service",our business mainly focus on the distribution of electronic components. Line cards we deal with include Microchip,ALPS,ROHM,Xilinx,Pulse,ON,Everlight and Freescale. Main products comprise IC,Modules,Potentiometer,IC Socket,Relay,Connector.Our parts cover such applications as commercial,industrial, and automotives areas.

We are looking forward to setting up business relationship with you and hope to provide you with the best service and solution. Let us make a better world for our industry!



Contact us

Tel: +86-755-8981 8866 Fax: +86-755-8427 6832

Email & Skype: info@chipsmall.com Web: www.chipsmall.com

Address: A1208, Overseas Decoration Building, #122 Zhenhua RD., Futian, Shenzhen, China



Delta/sigma cascade 20 bit stereo DAC

Features

- 20-bit resolution single ended output
- Analog reconstruction third order Chebyshev filter
- I²S input data format
- On chip PLL
- System clock: 64 Fs
- 2 output channels
- 0.9 VRMS single ended output dynamic
- 3.3 V power supply
- Reset
- Sampling rate 36 kHz to 48 kHz

Description

The TDA7535 is a stereo, digital-to-analog converter designed for audio applications, including digital interpolation filter, a third order multi-bit Delta-Sigma DAC, a third order Chebyshev's reconstruction filter and a differential to single ended output converter. This device is fabricated in highly advanced CMOS, where high speed precision analog circuits are combined with high density logic circuits. The TDA7535, according to standard audio converters, can accept any I²S data format.



The TDA7535 is available in SO14 package. The total power consumption is less than 75 mW.

TDA7535 is suitable for a wide variety of applications where high performance are required. Its low cost and single 3.3 V power supply make it ideal for several applications, such as CD players, MPEG audio, MIDI applications, CD-ROM drives, CD-Interactive, digital radio applications and so on. An evaluation board is available to perform measurement and to make listening tests.

Table 1. Device summary

Order code	Package	Packing
TDA7535	SO14	Tube
TDA7535013TR	SO14	Tape and reel

Contents

1	Block diagram and pin description	3
2	Electrical specification	4
2.1	Absolute maximum ratings	4
2.2	Thermal data	4
2.3	Recommended DC operating conditions	4
2.4	Power consumption	5
2.5	General interface electrical characteristics	5
2.6	Low voltage CMOS interface DC electrical characteristics	5
2.7	DAC electrical characteristics	6
3	I²S interface	7
4	Application circuit	9
5	Package information	10
6	Revision history	11

Obsolete Product(s) - Obsolete Product(s)

1 Block diagram and pin description

Figure 1. Block diagram

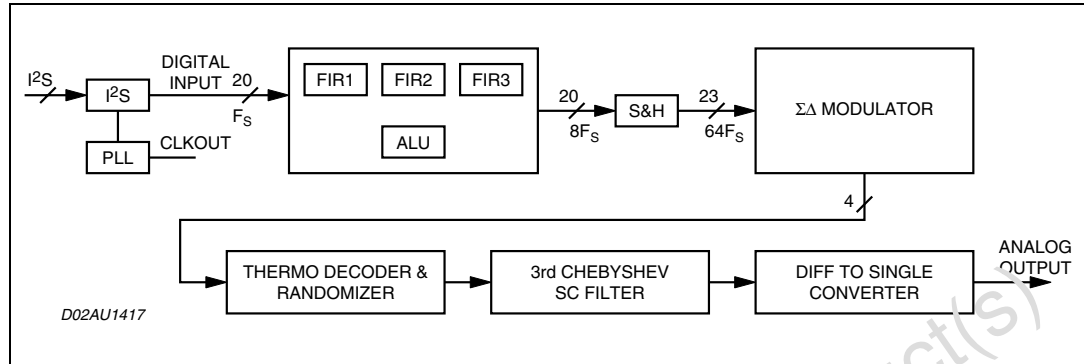

Figure 2. Pin connection (top view)

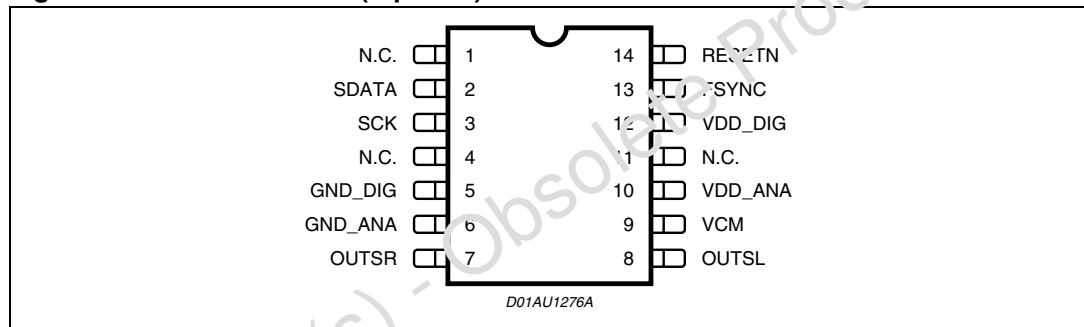

Table 2. Pin function

Pin #	Pin name	Input/output power	Description
1	N.C.	-	-
2	SDATA	I	I2S digital data input
3	SCK	I	I2S clock input
4	N.C.	-	-
5	GND_DIG	P	Digital ground
6	GND_ANA	P	Analog ground
7	OUTSR	O	Right channel single ended output
8	OUTSL	O	Left channel single ended output
9	VCM	P	Reference 1.65 V externally filtered
10	VDD_ANA	P	Analog 3.3 V supply
11	N.C.	-	-
12	VDD_DIG	P	Digital 3.3 V-supply
13	FSYNC	I	I2S Left-right channel selector
14	RESETN	I	Reset (active low)

2 Electrical specification

2.1 Absolute maximum ratings

Table 3. Absolute maximum ratings

Symbol	Parameter		Value	Unit
V _{DD} V _{CC}	Power supplies	Digital	-0.5 to +4.6	V
		Analog	-0.5 to +4.6	V
V _{aio}	Analog input and output voltage		-0.5 to (V _{CC} +0.5)	V
V _{dio}	Digital input and output voltage		-0.5 to (V _{DD} +0.5)	V
V _{di5}	Digital input voltage (5 V tolerant)		-0.5 to 6.5	V
T _j	Operating junction temperature range		-40 to 125	°C
T _{stg}	Storage temperature		-55 to 150	°C

Warning: Operation at or beyond these limits may result in permanent damage to the device. Normal operation is not guaranteed at these extremes.

2.2 Thermal data

Table 4. Thermal data

Symbol	Parameter	Value	Unit
R _{th j-amb}	Thermal resistance junction to ambient ⁽¹⁾	85	°C/W

1. In still air.

2.3 Recommended DC operating conditions

Table 5. Recommended DC operating conditions

Symbol	Parameter	Test condition	Min.	Typ.	Max.	Unit
V _{DD}	3.3 V digital power supply voltage		3.15	3.3	3.45	V
V _{CC}	3.3 V analog power supply voltage		3.15	3.3	3.45	V

2.4 Power consumption

Table 6. Power consumption

Symbol	Parameter	Test condition	Min.	Typ.	Max.	Unit
I_{dd}	Total maximum current	Power supply @ 3.3 V and $T_j = 125\text{ }^\circ\text{C}$		21.5	25	mA

2.5 General interface electrical characteristics

Table 7. General interface electrical characteristics

Symbol	Parameter	Test condition	Min.	Typ.	Max.	Unit
I_{il}	Low level input current without pull-up device	$V_i = 0\text{ V}^{(1)}$			1	μA
I_{ih}	High level input current without pull-up device	$V_i = V_{dd}^{(1)}$			1	μA
$I_{latchup}$	I/O latch-up current	$V < 0\text{ V}, V > V_{dd}$	200			mA
V_{esd}	Electrostatic protection	Leakage, $1\text{ }\mu\text{A}^{(2)}$	2000			V

1. The leakage currents are generally very small, $<1\text{ nA}$. The value given here, $1\text{ }\mu\text{A}$ is the maximum that can occur after an Electrostatic Stress on the pin.
2. Human body model.

2.6 Low voltage CMOS interface DC electrical characteristics

Table 8. Low voltage CMOS interface DC electrical characteristics

Symbol	Parameter	Test Condition	Min.	Typ.	Max.	Unit
V_{il}	Low Level Input Voltage				$0.2 \cdot V_d$	V
V_{ih}	High Level Input Voltage		$0.8 \cdot V_d$			V
V_{hyst}	Schmitt trigger hysteresis		0.8			V

2.7 DAC electrical characteristics

Table 9. DAC electrical characteristics

$V_{dd} = 3.3\text{ V}$; $T_{amb} = 25\text{ °C}$; Input signal frequency = sinus wave generated by audio precision Sys.2; Input signal amplitude (see notes); Noise integration bandwidth = 20 Hz to 22 kHz (A- weighted)

Parameter	Test condition	Min.	Typ.	Max.	Unit
Noise + distortion ⁽¹⁾	@ 0 dB		89		dB
	@ -6 dBb		94		dB
	@ -40 dB		96		dB
	@ -60 dB		96		dB
Total harmonic distortion	see note ⁽²⁾	70 ⁽³⁾	94		dB
Dynamic range	see note ⁽⁴⁾	84 ⁽⁵⁾	96		dB
Crosstalk	see note ⁽⁶⁾		-95		dB
Full scale output voltage	$V_{dd} = 3.15\text{ to }3.45\text{ V}$ Full scale input	0.8	0.9	1.0	Vrms
Input sampling rate		36		48	kHz
Passband ripple			0.12		dB
Stopband	@ 3dB	21.53		24.80	kHz
	@ 90dB				
	44.1kHz sampling rate				
Interchannel gain mismatch			0.05	0.1	dB

1. It is the ratio between the maximum input signal and the integration of the in-band noise after deducing the power of signal fundamental. It depends on the input signal amplitude. In this case 0dB means full scale digital, 1 kHz frequency used.
2. It is the ratio of the rms value of the signal fundamental component at 0 dB (full scale digital) to the rms value of all of the harmonic components in the band.
3. By correlation to beuch results. ATE limits are 60 dB.
4. Measured using the SNR at -60dB input signal, with 60dB added to compensate for small input signal.
5. By correlation to beuch results. ATE limits are 80 dB.
6. Left channel on with 0dB/1kHz input signal, Right channel on with DC input signal.

3 I²S interface

Figure 3. I²S interface diagram

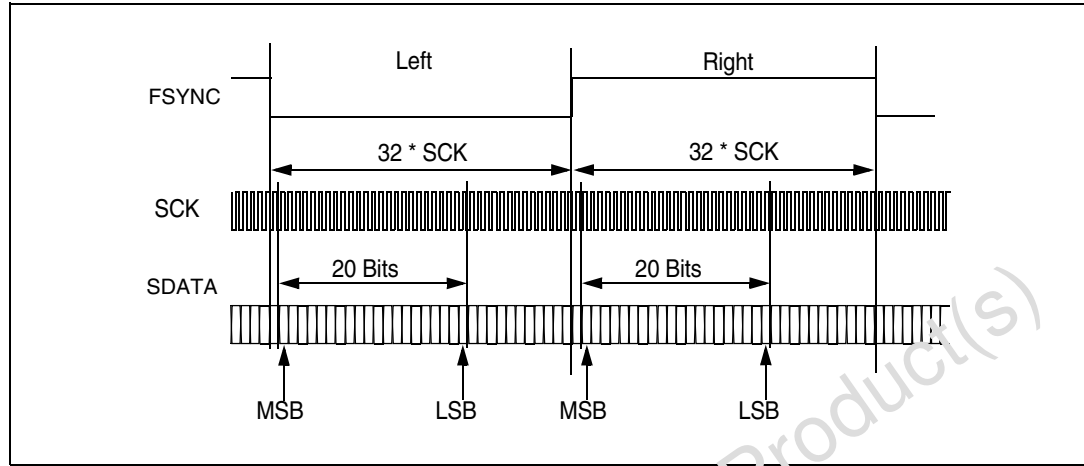

Figure 4. I²S timings

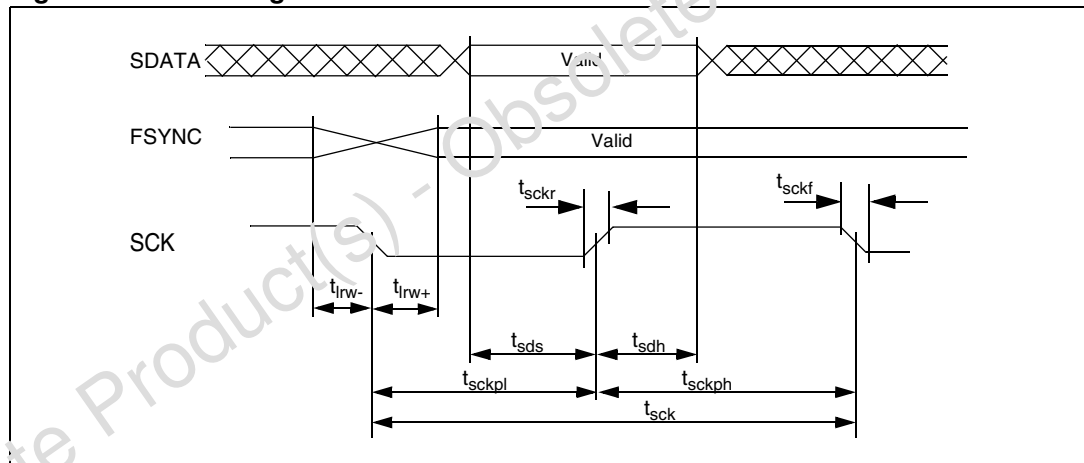

Table 10. Timing characteristics

Timing	Description	Min.	Max.	Unit
t _{sck}	Clock cycle ⁽¹⁾	1/(64*Fs) - 150ps _{RMS}	1/(64*Fs) + 150ps _{RMS}	ns
t _{sckpl}	SCK phase low	0.5*t _{sck} - 1%	0.5*t _{sck} + 1%	ns
t _{sckph}	SCK phase high	0.5*t _{sck} - 1%	0.5*t _{sck} + 1%	ns
t _{lrw-}	FSYNC switching time window before SCK falling edge ⁽²⁾	0	0.125*t _{sck} -10	ns
t _{lrw+}	FSYNC switching time window after SCK falling edge ⁽²⁾	0	0.125*t _{sck} -10	ns
t _{sds}	SDATA setup time	60		ns
t _{sdh}	SDATA hold time	30		ns

Table 10. Timing characteristics (continued)

Timing	Description	Min.	Max.	Unit
t _{sckr}	SCK rise time		22	ns
t _{sckf}	SCK fall time		20	ns

1. SCK clock defines the Fs, being the Sample Rate. This input clock needs a jitter below ~212ps_{RMS}.
2. FSYNC switches inside the time window as specified w.r.t. to falling edge of SCK.

Figure 5. Power up and reset sequence

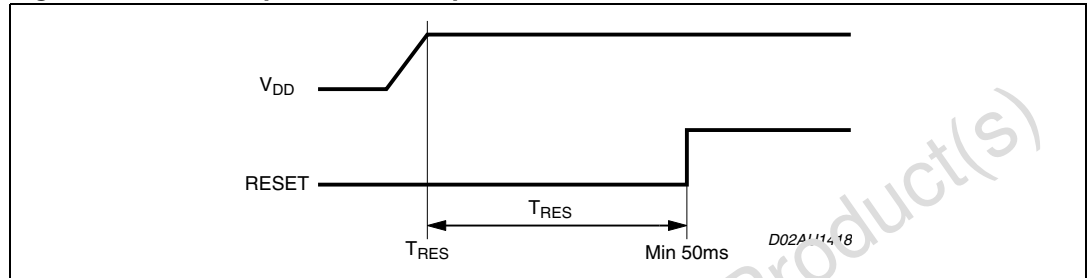
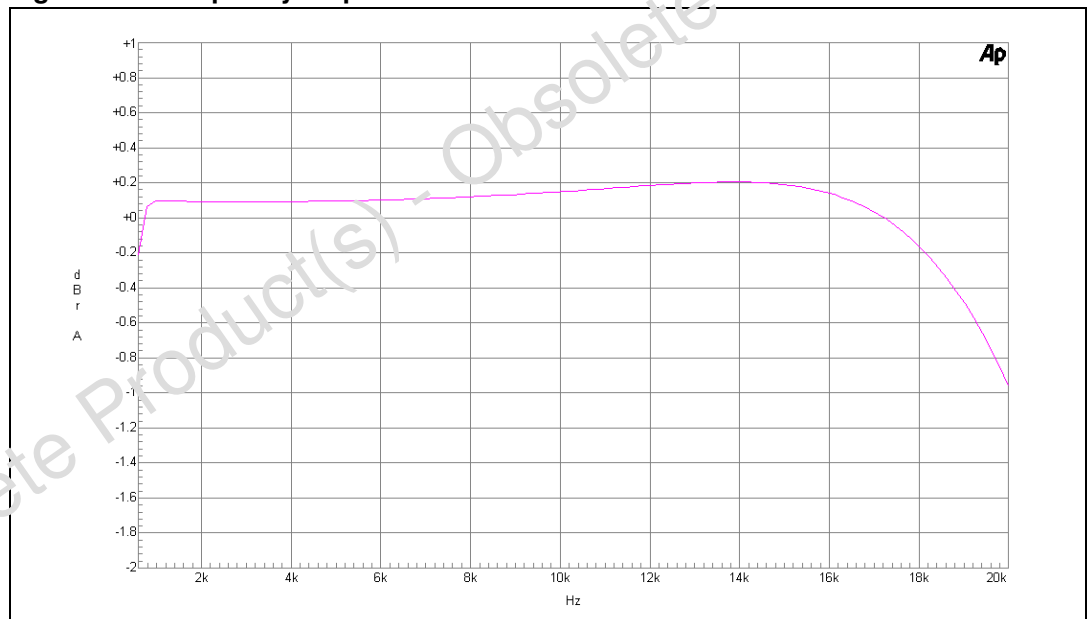
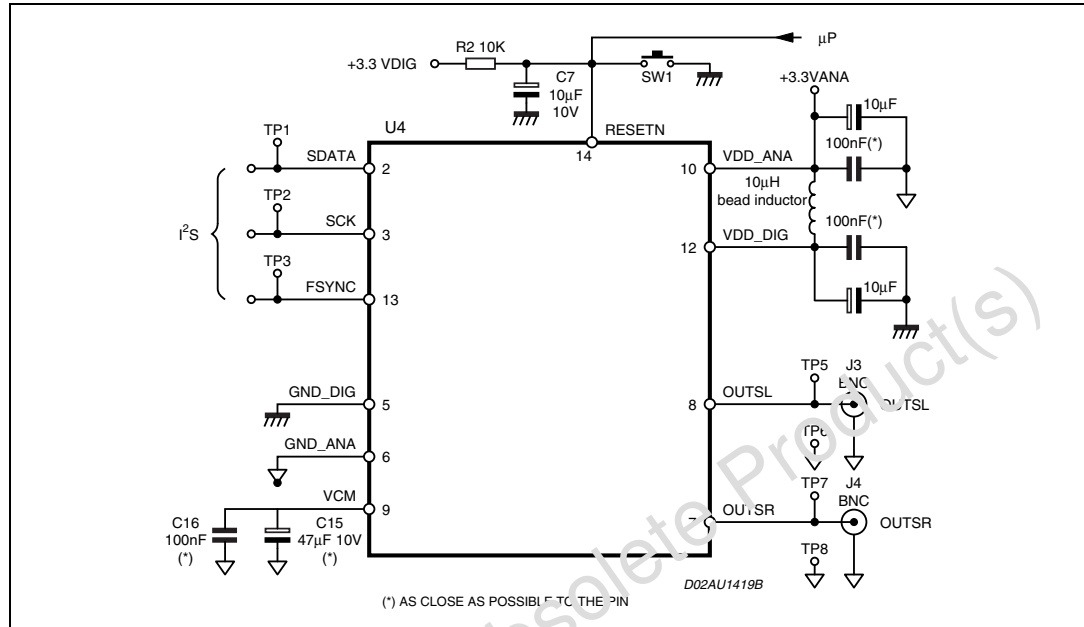

Figure 6. Frequency response



4 Application circuit

Figure 7. Application circuit



5 Package information

In order to meet environmental requirements, ST offers these devices in different grades of ECOPACK® packages, depending on their level of environmental compliance. ECOPACK® specifications, grade definitions and product status are available at: www.st.com.

ECOPACK® is an ST trademark.

Figure 8. SO14 mechanical data and package dimensions

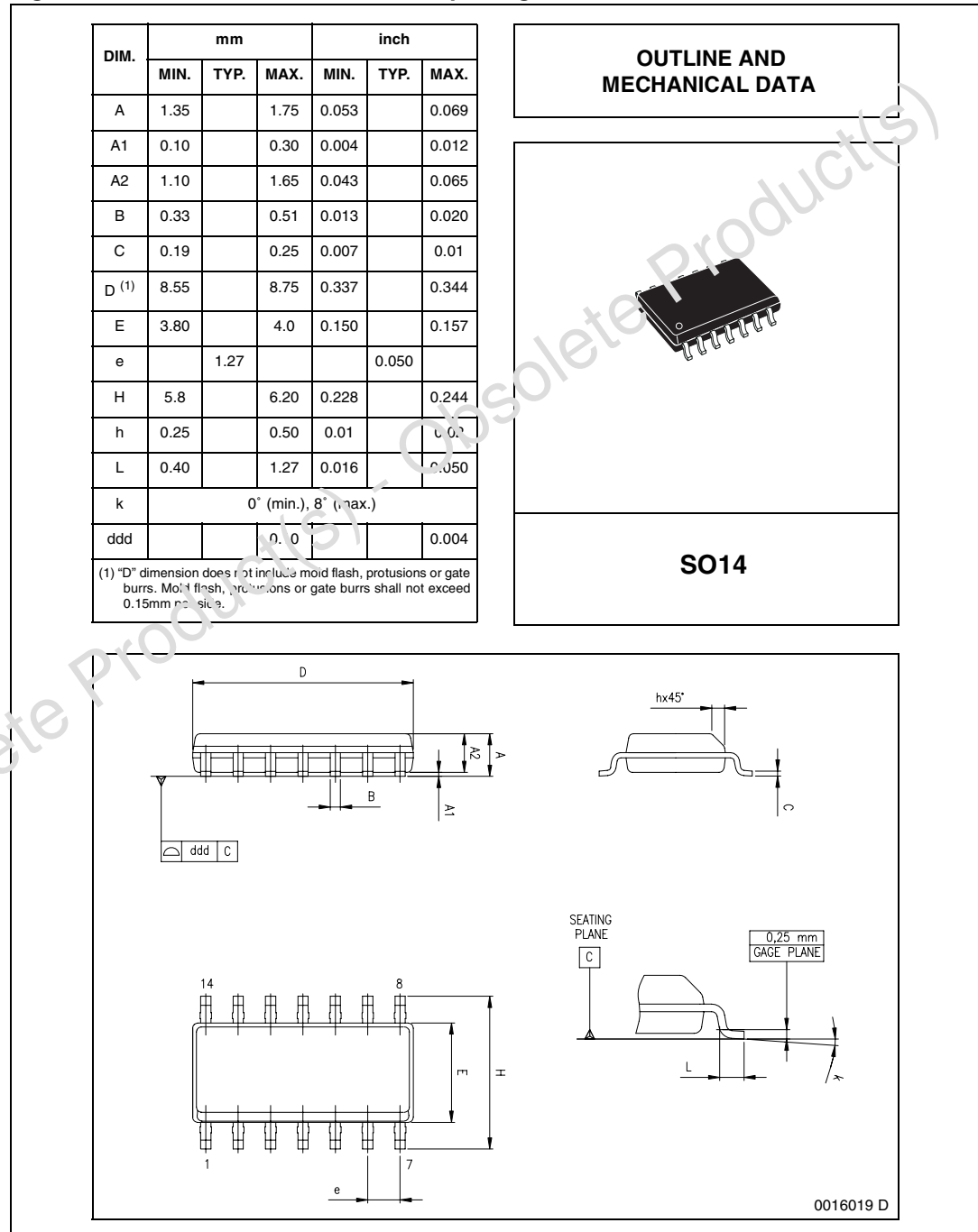

6 Revision history

Table 11. Document revision history

Date	Revision	Changes
13-Dec- 2003	5	Initial release.
21-Dec- 2005	6	Update electrical characteristics. Add revision history table.
03-Feb-2006	7	Updated max. value of t_{sckr} and t_{sckt} parameter on page 5/9.
06-Feb-2009	8	Document reformatted. Updated Section 5: Package information on page 10 .

Please Read Carefully:

Information in this document is provided solely in connection with ST products. STMicroelectronics NV and its subsidiaries ("ST") reserve the right to make changes, corrections, modifications or improvements, to this document, and the products and services described herein at any time, without notice.

All ST products are sold pursuant to ST's terms and conditions of sale.

Purchasers are solely responsible for the choice, selection and use of the ST products and services described herein, and ST assumes no liability whatsoever relating to the choice, selection or use of the ST products and services described herein.

No license, express or implied, by estoppel or otherwise, to any intellectual property rights is granted under this document. If any part of this document refers to any third party products or services it shall not be deemed a license grant by ST for the use of such third party products or services, or any intellectual property contained therein or considered as a warranty covering the use in any manner whatsoever of such third party products or services or any intellectual property contained therein.

UNLESS OTHERWISE SET FORTH IN ST'S TERMS AND CONDITIONS OF SALE ST DISCLAIMS ANY EXPRESS OR IMPLIED WARRANTY WITH RESPECT TO THE USE AND/OR SALE OF ST PRODUCTS INCLUDING WITHOUT LIMITATION IMPLIED WARRANTIES OF MERCHANTABILITY, FITNESS FOR A PARTICULAR PURPOSE (AND THEIR EQUIVALENTS UNDER THE LAWS OF ANY JURISDICTION), OR INFRINGEMENT OF ANY PATENT, COPYRIGHT OR OTHER INTELLECTUAL PROPERTY RIGHT.

UNLESS EXPRESSLY APPROVED IN WRITING BY AN AUTHORIZED ST REPRESENTATIVE, ST PRODUCTS ARE NOT RECOMMENDED, AUTHORIZED OR WARRANTED FOR USE IN MILITARY, AIR CRAFT, SPACE, LIFE SAVING, OR LIFE SUSTAINING APPLICATIONS, NOR IN PRODUCTS OR SYSTEMS WHERE FAILURE OR MALFUNCTION MAY RESULT IN PERSONAL INJURY, DEATH, OR SEVERE PROPERTY OR ENVIRONMENTAL DAMAGE. ST PRODUCTS WHICH ARE NOT SPECIFIED AS "AUTOMOTIVE GRADE" MAY ONLY BE USED IN AUTOMOTIVE APPLICATIONS AT USER'S OWN RISK.

Resale of ST products with provisions different from the statements and/or technical features set forth in this document shall immediately void any warranty granted by ST for the ST product or service described herein and shall not create or extend in any manner whatsoever, any liability of ST.

ST and the ST logo are trademarks or registered trademarks of ST in various countries.

Information in this document supersedes and replaces all information previously supplied.

The ST logo is a registered trademark of STMicroelectronics. All other names are the property of their respective owners.

© 2009 STMicroelectronics - All rights reserved

STMicroelectronics group of companies

Australia - Belgium - Brazil - Canada - China - Czech Republic - Finland - France - Germany - Hong Kong - India - Israel - Italy - Japan - Malaysia - Malta - Morocco - Singapore - Spain - Sweden - Switzerland - United Kingdom - United States of America

www.st.com