



Chipsmall Limited consists of a professional team with an average of over 10 year of expertise in the distribution of electronic components. Based in Hongkong, we have already established firm and mutual-benefit business relationships with customers from,Europe,America and south Asia,supplying obsolete and hard-to-find components to meet their specific needs.

With the principle of "Quality Parts,Customers Priority,Honest Operation,and Considerate Service",our business mainly focus on the distribution of electronic components. Line cards we deal with include Microchip,ALPS,ROHM,Xilinx,Pulse,ON,Everlight and Freescale. Main products comprise IC,Modules,Potentiometer,IC Socket,Relay,Connector.Our parts cover such applications as commercial,industrial, and automotives areas.

We are looking forward to setting up business relationship with you and hope to provide you with the best service and solution. Let us make a better world for our industry!



## Contact us

Tel: +86-755-8981 8866 Fax: +86-755-8427 6832

Email & Skype: info@chipsmall.com Web: www.chipsmall.com

Address: A1208, Overseas Decoration Building, #122 Zhenhua RD., Futian, Shenzhen, China



## 3 band car audio processor

### Features

- Input multiplexer
  - QD1: quasi-differential stereo inputs
  - SE1: stereo single-ended input
  - SE2: stereo single-ended input
  - SE3: stereo single-ended input
  - FD1 / SE4+SE5: 1 full-differential input or 2 stereo single-ended inputs
- Loudness
  - 2<sup>nd</sup> order frequency response
  - Programmable center frequency (400 Hz / 800 Hz / 2400 Hz)
  - 15 dB with 1 dB steps
  - Selectable high frequency boost
  - Selectable flat-mode (constant attenuation)
- Volume
  - +23 dB to -31 dB with 1 dB step resolution
  - Soft-step control with programmable blend times
- Bass
  - 2<sup>nd</sup> order frequency response
  - Center frequency programmable in 4 steps (60 Hz / 80 Hz / 100 Hz / 200 Hz)
  - Q programmable 1.0/1.25/1.5/2.0
  - DC gain programmable
  - -15 dB to 15 dB range with 1 dB resolution
- Middle
  - 2<sup>nd</sup> order frequency response
  - Center frequency programmable in 4 steps (500 Hz / 1 kHz / 1.5 kHz / 2.5 kHz)
  - Q programmable 0.75/1.0/1.25
  - -15 dB to 15 dB range with 1 dB resolution
- Treble
  - 2<sup>nd</sup> order frequency response (10 kHz / 12.5 kHz / 15 kHz / 17.5 kHz)
  - Center frequency programmable in 4 steps (10 kHz / 12.5 kHz / 15 kHz / 17.5 kHz)
  - -15 dB to 15 dB with 1 dB resolution

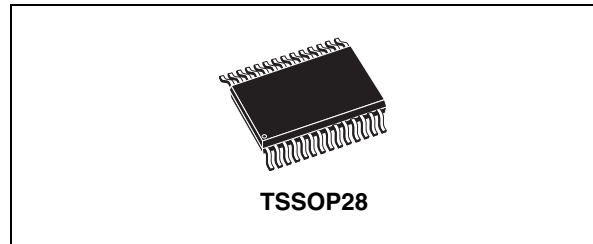

- Speaker
  - 4 independent soft step speaker controls
  - +15 dB to -79 dB with 1 dB steps
  - Direct mute
- Subwoofer
  - 2<sup>nd</sup> order low pass filter with programmable cut off frequency (55 Hz / 85 Hz / 120 Hz / 160 Hz)
  - 2 independent soft step level control, +15 dB to -79 dB with 1 dB steps
- Mute functions
  - Direct mute
  - Digitally controlled SoftMute with 4 programmable mute-times (0.48 ms/0.96 ms/8 ms/16 ms)
- Offset detection
  - Offset voltage detection circuit for on-board power amplifier failure diagnosis

### Description

The TDA7718N is a high performance signal processor specifically designed for car radio applications. The device includes a high performance audioprocessor with fully integrated audio filters and new Soft Step architecture. The digital control allows programming in a wide range of filter characteristics.

**Table 1. Device summary**

| Order code | Package | Packing       |
|------------|---------|---------------|
| TDA7718N   | TSSOP28 | Tube          |
| TDA7718NTR | TSSOP28 | Tape and reel |

# Contents

- 1      Block circuit diagram ..... 6**
- 2      Pin connection and pin description ..... 7**
  - 2.1 Pin connection ..... 7
  - 2.2 Pin description ..... 7
- 3      Electrical specifications ..... 9**
  - 3.1 Thermal data ..... 9
  - 3.2 Absolute maximum ratings ..... 9
  - 3.3 Electrical characteristics ..... 9
- 4      Description of the audioprocessor ..... 13**
  - 4.1 Input stages ..... 13
    - 4.1.1 Quasi-differential stereo input (QD1) ..... 13
    - 4.1.2 Single-ended stereo input (SE1, SE2, SE3) ..... 13
    - 4.1.3 Full-differential stereo input or single-ended input (FD1/QD2/SE4+SE5) 13
  - 4.2 Loudness ..... 15
    - 4.2.1 Loudness attenuation ..... 15
    - 4.2.2 Peak frequency ..... 15
    - 4.2.3 High frequency boost ..... 16
    - 4.2.4 Flat mode ..... 16
  - 4.3 SoftMute ..... 17
  - 4.4 SoftStep volume ..... 17
  - 4.5 Bass ..... 18
    - 4.5.1 Bass attenuation ..... 18
    - 4.5.2 Bass center frequency ..... 18
    - 4.5.3 Quality factors ..... 19
    - 4.5.4 DC mode ..... 19
  - 4.6 Middle ..... 20
    - 4.6.1 Middle attenuation ..... 20
    - 4.6.2 Middle center frequency ..... 20
    - 4.6.3 Quality factors ..... 21
  - 4.7 Treble ..... 21

---

|          |   |           |
|----------|---|-----------|
| 4.7.1    | Treble attenuation .....                              | 21        |
| 4.7.2    | Center frequency .....                                | 22        |
| 4.8      | Subwoofer filter .....                                | 22        |
| 4.9      | Softstep control .....                                | 23        |
| 4.10     | DC offset detector .....                              | 23        |
| 4.11     | Audioprocessor testing .....                          | 25        |
| <b>5</b> | <b>I<sup>2</sup>C bus specification .....</b>         | <b>26</b> |
| 5.1      | Interface protocol .....                              | 26        |
| 5.2      | I <sup>2</sup> C bus electrical characteristics ..... | 26        |
| 5.2.1    | Receive mode .....                                    | 27        |
| 5.2.2    | Transmission mode .....                               | 27        |
| 5.2.3    | Reset condition .....                                 | 27        |
| 5.3      | Data byte specification .....                         | 29        |
| <b>6</b> | <b>Package information .....</b>                      | <b>38</b> |
| <b>7</b> | <b>Revision history .....</b>                         | <b>39</b> |



## List of tables

|           |   |    |
|-----------|---|----|
| Table 1.  | Device summary . . . . .                                    | 1  |
| Table 2.  | Pin description . . . . .                                   | 7  |
| Table 3.  | Thermal data . . . . .                                      | 9  |
| Table 4.  | Absolute maximum ratings . . . . .                          | 9  |
| Table 5.  | Electrical characteristics . . . . .                        | 9  |
| Table 6.  | I <sup>2</sup> C bus electrical characteristics . . . . .   | 26 |
| Table 7.  | Subaddress (receive mode) . . . . .                         | 28 |
| Table 8.  | Main selector (0) . . . . .                                 | 29 |
| Table 9.  | Soft mute / others (4) . . . . .                            | 30 |
| Table 10. | SoftStep I (5) . . . . .                                    | 31 |
| Table 11. | SoftStep II / DC detector (6) . . . . .                     | 32 |
| Table 12. | Loudness (7) . . . . .                                      | 33 |
| Table 13. | Volume / output gain (8) . . . . .                          | 33 |
| Table 14. | Treble filter (9) . . . . .                                 | 34 |
| Table 15. | Middle filter (10) . . . . .                                | 34 |
| Table 16. | Bass filter (11) . . . . .                                  | 35 |
| Table 17. | Subwoofer / middle / bass (12) . . . . .                    | 35 |
| Table 18. | Speaker attenuation (FL/FR/RL/RR/SWL/SWR) (13-18) . . . . . | 36 |
| Table 19. | Testing audio processor 1 (19) . . . . .                    | 36 |
| Table 20. | Testing audio processor 2 (20) . . . . .                    | 37 |
| Table 21. | Testing audio processor 3 (21) . . . . .                    | 37 |
| Table 22. | Document revision history . . . . .                         | 39 |

## List of figures

|            |   |    |
|------------|---|----|
| Figure 1.  | Block circuit diagram. . . . .                                  | 6  |
| Figure 2.  | Pin connection (top view) . . . . .                             | 7  |
| Figure 3.  | FD / QD / SE block diagram . . . . .                            | 14 |
| Figure 4.  | Loudness attenuation @ $f_P = 400$ Hz. . . . .                  | 15 |
| Figure 5.  | Loudness center frequencies @ attn. = 15 dB. . . . .            | 15 |
| Figure 6.  | Loudness attenuation, $f_C = 2.4$ kHz. . . . .                  | 16 |
| Figure 7.  | SoftMute timing. . . . .  | 17 |
| Figure 8.  | Bass control @ $f_C = 80$ Hz, $Q = 1$ . . . . .                 | 18 |
| Figure 9.  | Bass center frequencies @ gain = 14 dB, $Q = 1$ . . . . .       | 18 |
| Figure 10. | Bass quality factors @ gain = 14 dB, $f_C = 80$ Hz . . . . .    | 19 |
| Figure 11. | Bass normal and DC mode @ gain = 14 dB, $f_C = 80$ Hz . . . . . | 19 |
| Figure 12. | Middle control @ $f_C = 1$ kHz, $Q = 1$ . . . . .               | 20 |
| Figure 13. | Middle center frequencies @ gain = 14 dB, $Q = 1$ . . . . .     | 20 |
| Figure 14. | Middle quality factors @ gain = 14 dB, $f_C = 1$ kHz . . . . .  | 21 |
| Figure 15. | Treble control @ $f_C = 17.5$ kHz. . . . .                      | 21 |
| Figure 16. | Treble center frequencies @ gain = 14 dB. . . . .               | 22 |
| Figure 17. | Subwoofer cut frequencies . . . . .                             | 22 |
| Figure 18. | DC offset detection circuit (simplified) . . . . .              | 24 |
| Figure 19. | Test circuit . . . . .  | 25 |
| Figure 20. | I <sup>2</sup> C bus interface protocol . . . . .               | 26 |
| Figure 21. | I <sup>2</sup> C bus data . . . . .                             | 27 |
| Figure 22. | TSSOP28 mechanical data and package dimensions . . . . .        | 38 |

# 1 Block circuit diagram

Figure 1. Block circuit diagram

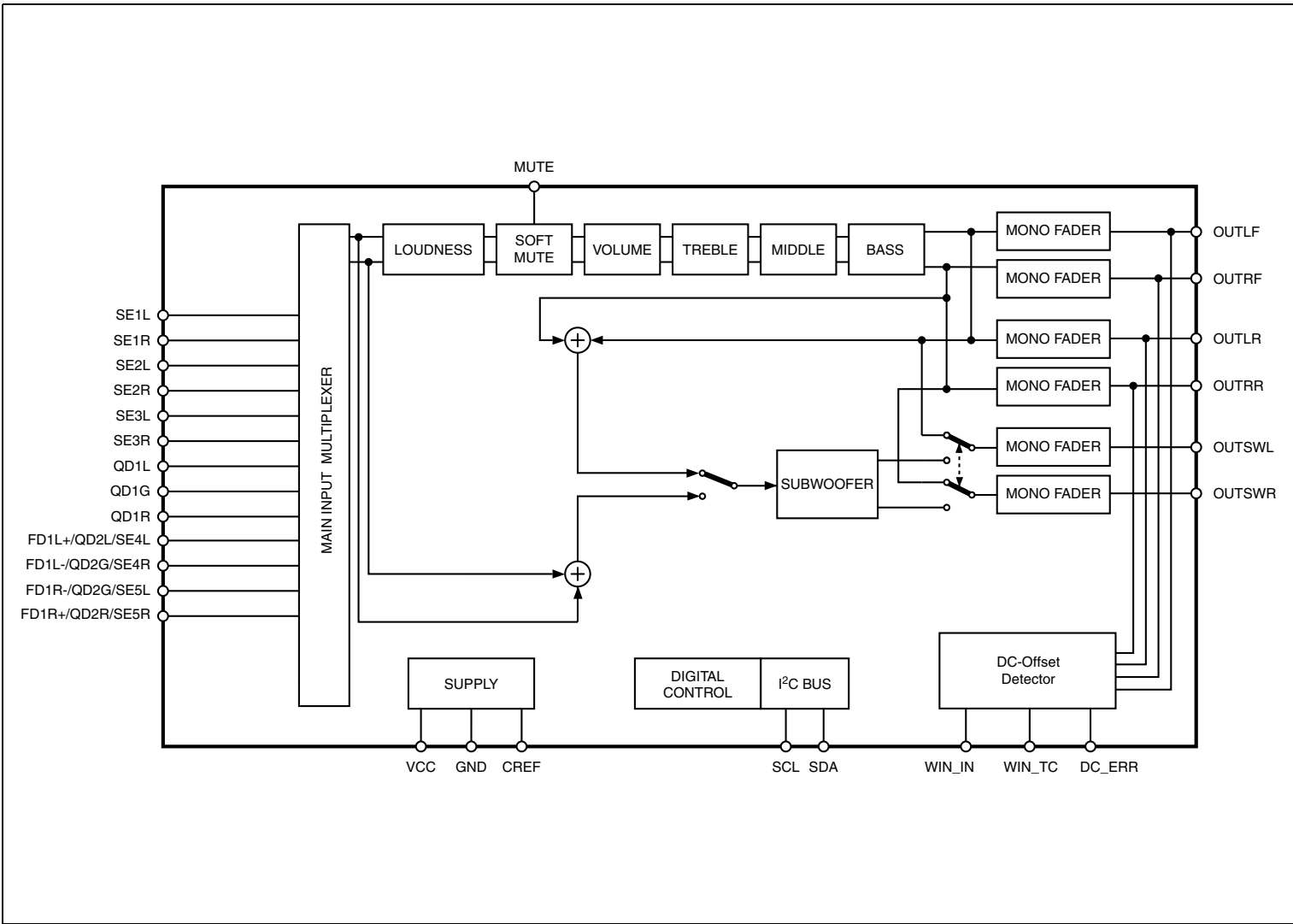

## 2 Pin connection and pin description

### 2.1 Pin connection

Figure 2. Pin connection (top view)

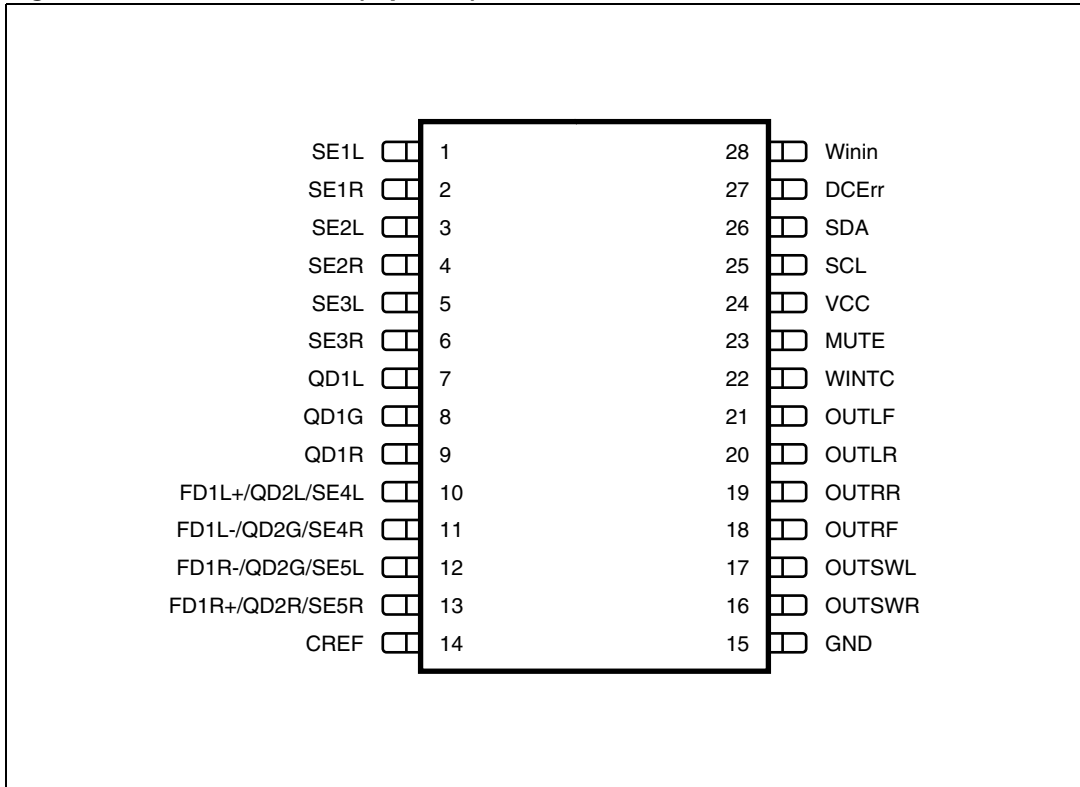

### 2.2 Pin description

Table 2. Pin description

| No. | Pin name        | Description  | I/O |
|-----|-----------------|--|-----|
| 1   | SE1L            | Single-end input left  | I   |
| 2   | SE1R            | Single-end input right   | I   |
| 3   | SE2L            | Single-end input left  | I   |
| 4   | SE2R            | Single-end input right   | I   |
| 5   | SE3L            | Single-end input left  | I   |
| 6   | SE3R            | Single-end input right   | I   |
| 7   | QD1L            | quasi-differential stereo inputs left  | I   |
| 8   | QD1G            | quasi-differential stereo inputs common  | I   |
| 9   | QD1R            | quasi-differential stereo inputs right   | I   |
| 10  | FD1L+/QD2L/SE4L | Full differential + input left or quasi-differential left or single-end input left | I   |



Table 2. Pin description (continued)

| No. | Pin name        | Description   | I/O |
|-----|-----------------|---|-----|
| 11  | FD1L-/QD2G/SE4R | Full differential - input left or quasi-differential ground or single-end input right | I   |
| 12  | FD1R-/QD2G/SE5L | Full differential - input right or quasi-differential ground or single-end input left | I   |
| 13  | FD1R+/QD2R/SE5R | Full differential + input right or quasi-differential right or single-end input right | I   |
| 14  | CREF            | Reference capacitor   | O   |
| 15  | GND             | Ground  | S   |
| 16  | OUTSWR          | Subwoofer right output  | O   |
| 17  | OUTSWL          | Subwoofer left output   | O   |
| 18  | OUTRF           | Front right output  | O   |
| 19  | OUTRR           | Rear right output   | O   |
| 20  | OUTLR           | Rear left output  | O   |
| 21  | OUTLF           | Front left output   | O   |
| 22  | WinTC           | DC offset detector filter output  | O   |
| 23  | MUTE            | External mute pin   | I   |
| 24  | VCC             | Supply  | S   |
| 25  | SCL             | I <sup>2</sup> C bus clock  | I   |
| 26  | SDA             | I <sup>2</sup> C bus data   | I/O |
| 27  | DC_ERR          | DC offset detector output   | O   |
| 28  | WIN_IN          | DC offset detector input  | I   |

## 3 Electrical specifications

### 3.1 Thermal data

Table 3. Thermal data

| Symbol          | Description                            | Value | Unit |
|-----------------|--|-------|------|
| $R_{th-j\ amb}$ | Thermal resistance junction-to-ambient | 114   | °C/W |

### 3.2 Absolute maximum ratings

Table 4. Absolute maximum ratings

| Symbol        | Parameter                             | Value      | Unit |
|---------------|---------------------------------------|------------|------|
| $V_S$         | Operating supply voltage              | 10.5       | V    |
| $V_{in\_max}$ | Maximum voltage for signal input pins | 7          | V    |
| $T_{amb}$     | Operating ambient temperature         | -40 to 85  | °C   |
| $T_{stg}$     | Storage temperature range             | -55 to 150 | °C   |

### 3.3 Electrical characteristics

$V_S = 8.5\text{ V}$ ;  $T_{amb} = 25\text{ °C}$ ;  $R_L = 10\text{ k}\Omega$ ; all gains = 0 dB;  $f = 1\text{ kHz}$ ; unless otherwise specified

Table 5. Electrical characteristics

| Symbol                            | Parameter                                   | Test condition                              | Min. | Typ. | Max. | Unit          |
|-----------------------------------|---|---|------|------|------|---------------|
| <b>Supply</b>                     |   |   |      |      |      |               |
| $V_S$                             | Supply voltage                              | -   | 7.5  | 8.5  | 10   | V             |
| $I_S$                             | Supply current                              | -   | 23   | 29   | 35   | mA            |
| <b>Input selector</b>             |   |   |      |      |      |               |
| $R_{in}$                          | Input resistance                            | All single ended inputs                     | 70   | 100  | 130  | k $\Omega$    |
| $V_{CL}$                          | Clipping level                              | Input gain = 0 dB                           | 2    | -    | -    | $V_{RMS}$     |
| $S_{IN}$                          | Input separation                            | -   | -    | 95   | -    | dB            |
| <b>Differential stereo inputs</b> |   |   |      |      |      |               |
| $R_{in}$                          | Input resistance                            | Differential                                | 70   | 100  | -    | k $\Omega$    |
| CMRR                              | Common mode rejection ratio for main source | $V_{CM} = 1\text{ V}_{RMS}$ @ 1 kHz         | 44   | 60   | -    | dB            |
|                                   |   | $V_{CM} = 1\text{ V}_{RMS}$ @ 10 kHz        | 44   | 60   | -    | dB            |
| $e_{No}$                          | Output noise @ speaker outputs              | 20 Hz - 20 kHz, A-weighted; all stages 0 dB | -    | 12   | 22   | $\mu\text{V}$ |

**Table 5. Electrical characteristics (continued)**

| Symbol                  | Parameter                 | Test condition              | Min.      | Typ.      | Max.      | Unit       |
|-------------------------|---------------------------|-----------------------------|-----------|-----------|-----------|------------|
| <b>Loudness control</b> |                           |                             |           |           |           |            |
| $A_{MAX}$               | Max attenuation           | -                           | 14        | 15        | 16        | dB         |
| $A_{STEP}$              | Step resolution           | -                           | 0.5       | 1         | 1.5       | dB         |
| $f_{Peak}$              | Peak frequency            | $f_{P1}$                    | -         | 400       | -         | Hz         |
|                         |                           | $f_{P2}$                    | -         | 800       | -         | Hz         |
|                         |                           | $f_{P3}$                    | -         | 2400      | -         | Hz         |
| <b>Volume control</b>   |                           |                             |           |           |           |            |
| $G_{MAX}$               | Max gain                  | -                           | 22        | 23        | 24        | dB         |
| $A_{MAX}$               | Max attenuation           | -                           | -         | -31       | -30       | dB         |
| $A_{STEP}$              | Step resolution           | -                           | 0.5       | 1         | 1.5       | dB         |
| $E_A$                   | Attenuation set error     | -                           | -0.75     | 0         | +0.75     | dB         |
| $E_T$                   | Tracking error            | -                           | -         | -         | 2         | dB         |
| $V_{DC}$                | DC steps                  | Adjacent attenuation steps  | -3        | 0.1       | 3         | mV         |
|                         |                           | From 0 dB to $G_{MIN}$      | -5        | 0.5       | 5         | mV         |
| <b>Soft mute</b>        |                           |                             |           |           |           |            |
| $A_{MUTE}$              | Mute attenuation          | -                           | 80        | 100       | -         | dB         |
| $T_D$                   | Delay time                | T1                          | 0.35      | 0.48      | 0.65      | ms         |
|                         |                           | T2                          | 0.7       | 0.96      | 1.3       | ms         |
|                         |                           | T3                          | 5.6       | 7.6       | 9.6       | ms         |
|                         |                           | T4                          | 12.3      | 15.3      | 18.3      | ms         |
| $V_{TH\ Low}$           | Low threshold for SM pin  | -                           | -         | -         | 1         | V          |
| $V_{TH\ High}$          | High threshold for SM pin | -                           | 2.5       | -         | -         | V          |
| $R_{PU}$                | Internal pull-up resistor | -                           | 32        | 45        | 58        | k $\Omega$ |
| $V_{PU}$                | Internal pull-up voltage  | -                           | 3         | 3.3       | 3.6       | V          |
| <b>Bass control</b>     |                           |                             |           |           |           |            |
| $F_c$                   | Center frequency          | $f_{C1}$                    | -         | 60        | -         | Hz         |
|                         |                           | $f_{C2}$                    | -         | 80        | -         | Hz         |
|                         |                           | $f_{C3}$                    | -         | 100       | -         | Hz         |
|                         |                           | $f_{C4}$                    | -         | 200       | -         | Hz         |
| $Q_{BASS}$              | Quality factor            | $Q_1$                       | -         | 1         | -         | -          |
|                         |                           | $Q_2$                       | -         | 1.25      | -         | -          |
|                         |                           | $Q_3$                       | -         | 1.5       | -         | -          |
|                         |                           | $Q_4$                       | -         | 2         | -         | -          |
| $C_{RANGE}$             | Control range             | -                           | $\pm 14$  | $\pm 15$  | $\pm 16$  | dB         |
| $A_{STEP}$              | Step resolution           | -                           | 0.5       | 1         | 1.5       | dB         |
| $DC_{GAIN}$             | Bass-DC-gain              | DC = off                    | -1        | 0         | +1        | dB         |
|                         |                           | DC = on, gain = $\pm 15$ dB | $\pm 4.3$ | $\pm 4.7$ | $\pm 5.1$ | dB         |

Table 5. Electrical characteristics (continued)

| Symbol                     | Parameter                | Test condition             | Min. | Typ. | Max. | Unit             |
|----------------------------|--------------------------|----------------------------|------|------|------|------------------|
| <b>Middle control</b>      |                          |                            |      |      |      |                  |
| C <sub>RANGE</sub>         | Control range            | -                          | ±14  | ±15  | ±16  | dB               |
| A <sub>STEP</sub>          | Step resolution          | -                          | 0.5  | 1    | 1.5  | dB               |
| f <sub>c</sub>             | Center frequency         | f <sub>C1</sub>            | -    | 500  | -    | Hz               |
|                            |                          | f <sub>C2</sub>            | -    | 1    | -    | kHz              |
|                            |                          | f <sub>C3</sub>            | -    | 1.5  | -    | kHz              |
|                            |                          | f <sub>C4</sub>            | -    | 2.5  | -    | kHz              |
| Q <sub>MIDDLE</sub>        | Quality factor           | Q <sub>1</sub>             | -    | 0.75 | -    | -                |
|                            |                          | Q <sub>2</sub>             | -    | 1    | -    | -                |
|                            |                          | Q <sub>3</sub>             | -    | 1.25 | -    | -                |
| <b>Treble control</b>      |                          |                            |      |      |      |                  |
| C <sub>RANGE</sub>         | Clipping level           | -                          | ±14  | ±15  | ±16  | dB               |
| A <sub>STEP</sub>          | Step resolution          | -                          | 0.5  | 1    | 1.5  | dB               |
| f <sub>c</sub>             | Center frequency         | f <sub>C1</sub>            | -    | 10   | -    | kHz              |
|                            |                          | f <sub>C2</sub>            | -    | 12.5 | -    | kHz              |
|                            |                          | f <sub>C3</sub>            | -    | 15   | -    | kHz              |
|                            |                          | f <sub>C4</sub>            | -    | 17.5 | -    | kHz              |
| <b>Speaker attenuators</b> |                          |                            |      |      |      |                  |
| G <sub>MAX</sub>           | Max gain                 | -                          | 14   | 15   | 16   | dB               |
| A <sub>MAX</sub>           | Max attenuation          | -                          | -    | -79  | -74  | dB               |
| A <sub>STEP</sub>          | Step resolution          | -                          | 0.5  | 1    | 1.5  | dB               |
| A <sub>MUTE</sub>          | Mute attenuation         | -                          | 80   | 90   | -    | dB               |
| E <sub>E</sub>             | Attenuation set error    | -                          | -    | -    | 2    | dB               |
| V <sub>DC</sub>            | DC steps                 | Adjacent attenuation steps | -    | 0.1  | 5    | mV               |
| <b>Audio outputs</b>       |                          |                            |      |      |      |                  |
| V <sub>CL</sub>            | Clipping level           | d = 0.3 %; byte8_D6=1      | 2    | -    | -    | V <sub>RMS</sub> |
|                            |                          | d = 1 %; byte8_D6=0        | 2.2  | -    | -    | V <sub>RMS</sub> |
| R <sub>OUT</sub>           | Output impedance         | -                          | -    | 30   | 100  | Ω                |
| R <sub>L</sub>             | Output load resistance   | -                          | 2    | -    | -    | kΩ               |
| C <sub>L</sub>             | Output load capacitor    | -                          | -    | -    | 10   | nF               |
| V <sub>DC</sub>            | DC voltage level         | -                          | 3.8  | 4.0  | 4.2  | V                |
| <b>Subwoofer lowpass</b>   |                          |                            |      |      |      |                  |
| f <sub>LP</sub>            | Lowpass corner frequency | f <sub>LP1</sub>           | -    | 55   | -    | Hz               |
|                            |                          | f <sub>LP2</sub>           | -    | 85   | -    | Hz               |
|                            |                          | f <sub>LP3</sub>           | -    | 120  | -    | Hz               |
|                            |                          | f <sub>LP4</sub>           | -    | 160  | -    | Hz               |

Table 5. Electrical characteristics (continued)

| Symbol                             | Parameter                     | Test condition                                 | Min. | Typ. | Max. | Unit |
|------------------------------------|-------------------------------|--|------|------|------|------|
| <b>DC offset detection circuit</b> |                               |  |      |      |      |      |
| $V_{th}$                           | Zero comp. window size        | V1   | ±10  | ±25  | ±40  | mV   |
|                                    |                               | V2   | ±30  | ±50  | ±70  | mV   |
|                                    |                               | V3   | ±50  | ±75  | ±100 | mV   |
|                                    |                               | V4   | ±70  | ±100 | ±130 | mV   |
| $t_{sp}$                           | Max rejected spike length     | -  | 2    | 11   | 30   | µs   |
|                                    |                               | -  | 5    | 22   | 50   | µs   |
|                                    |                               | -  | 10   | 33   | 70   | µs   |
|                                    |                               | -  | 15   | 44   | 90   | µs   |
| $I_{CHDCerr}$                      | DCErr charge current          | -  | 2    | 5    | 8    | µA   |
| $I_{DISDCerr}$                     | DCErr discharge current       | -  | 4    | 5    | 9    | mA   |
| $V_{OutH}$                         | DCErr high voltage            | -  | 3    | 3.3  | 3.6  | V    |
| $V_{OutL}$                         | DCErr low voltage             | -  | -    | 100  | 300  | mV   |
| <b>General</b>                     |                               |  |      |      |      |      |
| $e_{NO}$                           | Output noise                  | BW=20 Hz to 20 kHz A-Weighted, all gain = 0 dB | -    | 12   | 22   | µV   |
|                                    |                               | BW=20 Hz - 20 kHz A-Weighted, Output muted     | -    | 7    | 12   | µV   |
| S/N                                | Signal to noise ratio         | all gain = 0 dB, A-weighted; $V_o = 2 V_{RMS}$ | 98   | 104  | -    | dB   |
| D                                  | Distortion                    | $V_{IN} = 1 V_{RMS}$ ; all stages 0 dB         | -    | 0.01 | 0.1  | %    |
| $S_C$                              | Channel separation left/right | -  | -    | 90   | -    | dB   |

## 4 Description of the audioprocessor

### 4.1 Input stages

One quasi-differential stereo input, one full-differential stereo input and maximum five single-ended inputs are available.

#### 4.1.1 Quasi-differential stereo input (QD1)

The QD input is implemented as a buffered quasi-differential stereo stage with 100 k $\Omega$  input-impedance at each input. There is -3 dB attenuation at QD input stage.

#### 4.1.2 Single-ended stereo input (SE1, SE2, SE3)

The input-impedance at each input is 100 k $\Omega$  and the attenuation is fixed to -3 dB for incoming signals.

#### 4.1.3 Full-differential stereo input or single-ended input (FD1/QD2/SE4+SE5)

This device provides a full-differential stereo input stage (FD1) or 2<sup>nd</sup> quasi-differential stereo input stage. The full differential is a buffered full-differential stereo stage with 100 k $\Omega$  input-impedance at each input. When using as QD2 application, it needs to connect the two QD2G pins together from external and the input impedance at QDG becomes 50 k $\Omega$ . This stage can be also configured as 2 single-ended stereo input stages (SE4 and SE5). The configuration is done with the input selector control bits and the selection of FD1 and QD2 is controlled by a separate bit. There is -3 dB attenuation at the input stage. [Figure 3](#) shows the block diagram of this input stage.



Figure 3. FD / QD / SE block diagram

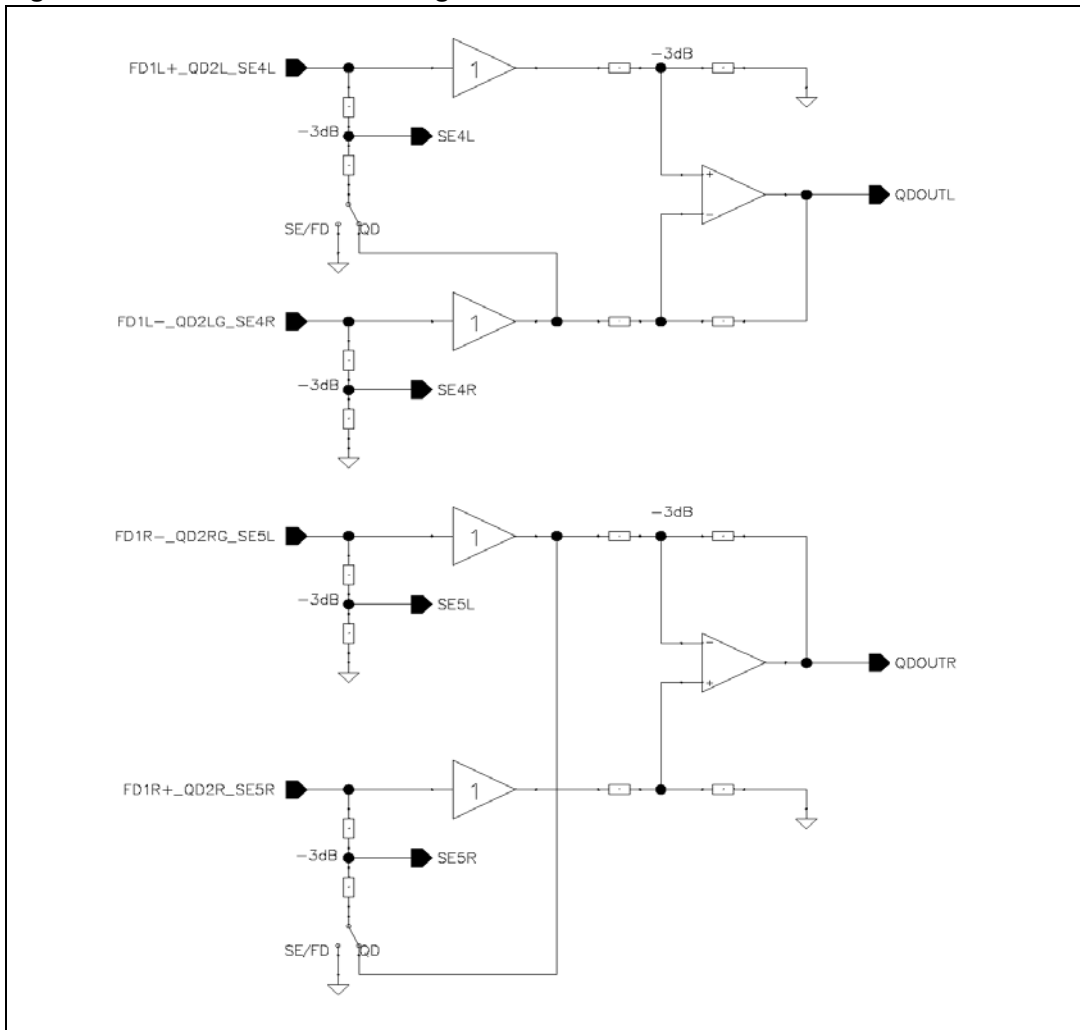

## 4.2 Loudness

There are four parameters programmable in the loudness stage.

### 4.2.1 Loudness attenuation

*Figure 4* shows the attenuation as a function of frequency at  $f_p = 400$  Hz.

**Figure 4. Loudness attenuation @  $f_p = 400$  Hz.**

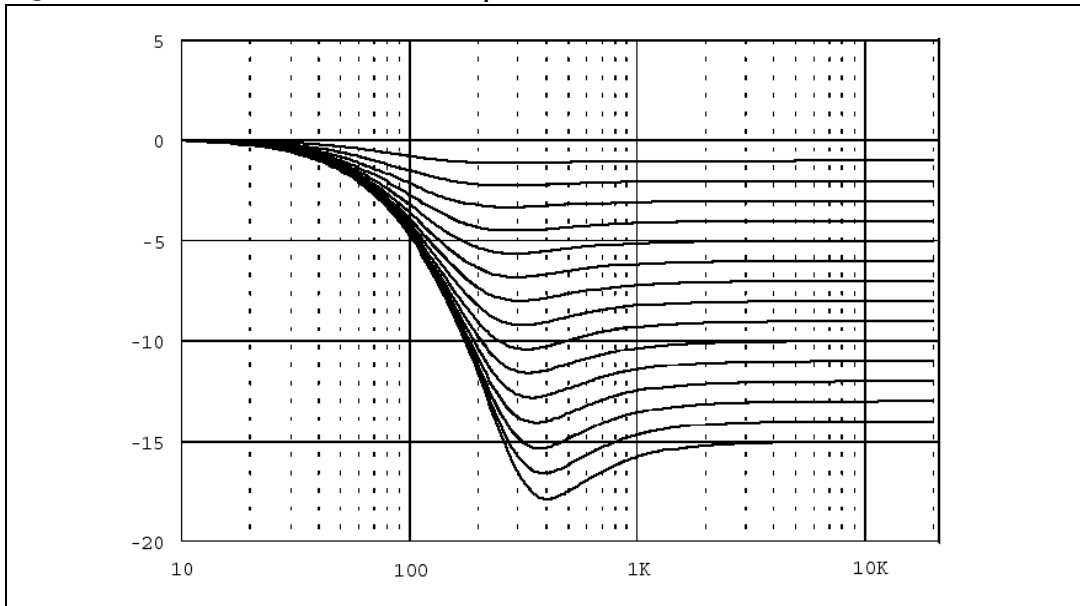

### 4.2.2 Peak frequency

*Figure 5* shows the four possible peak-frequencies at 400, 800 and 2400 Hz.

**Figure 5. Loudness center frequencies @ attn. = 15 dB.**

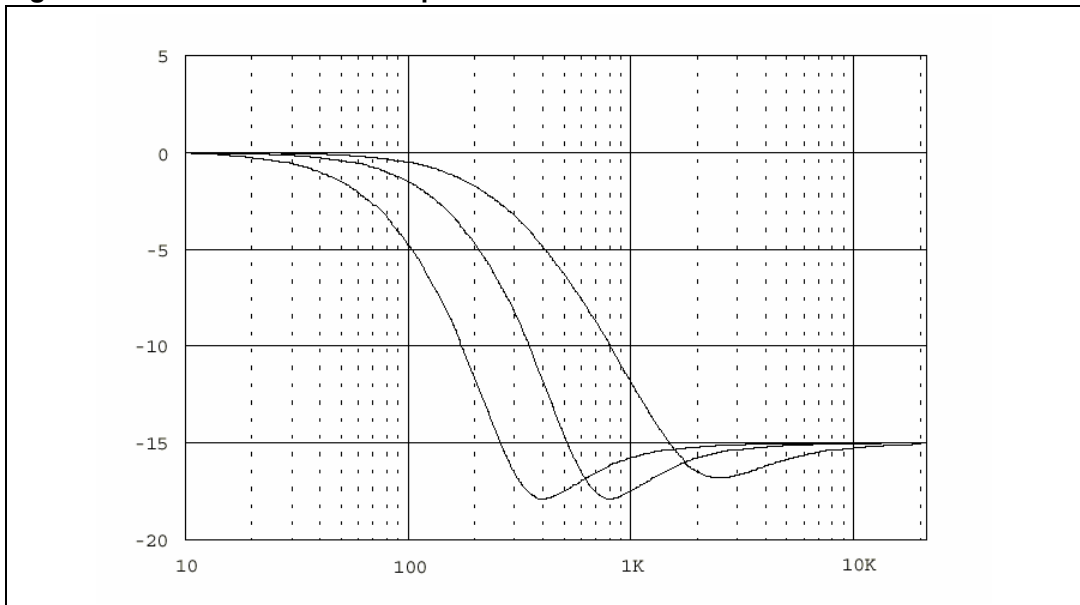

### 4.2.3 High frequency boost

*Figure 6* shows the different Loudness shapes in low and high frequency boost.

**Figure 6.** Loudness attenuation,  $f_c = 2.4$  kHz

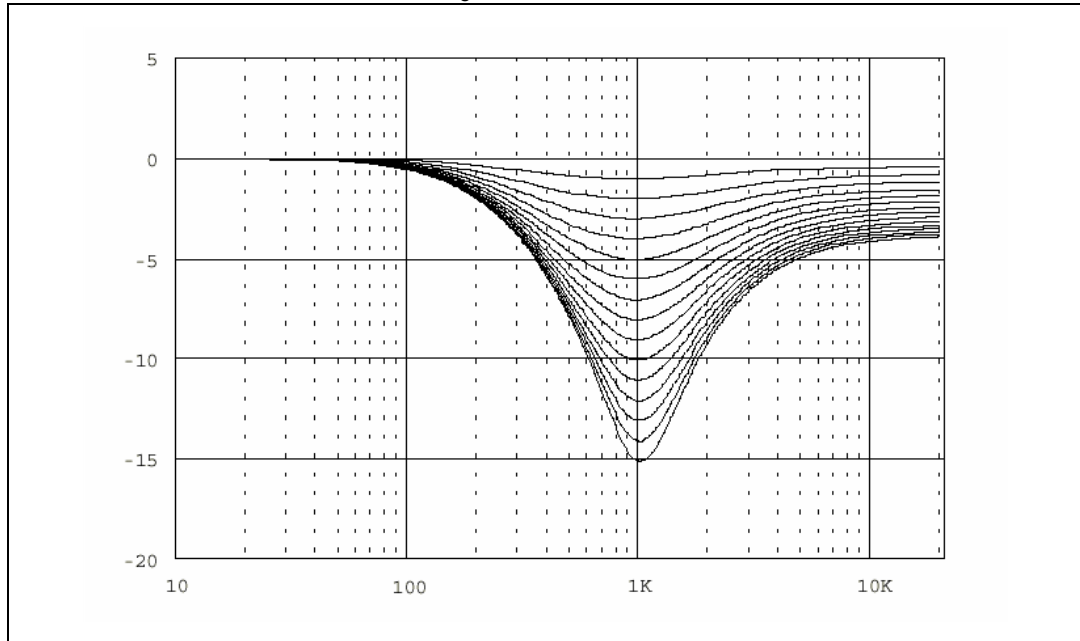

### 4.2.4 Flat mode

In flat mode the loudness stage works as a 0 dB to -15 dB attenuator.

### 4.3 SoftMute

The digitally controlled SoftMute stage allows muting/demuting the signal with a I<sup>2</sup>C bus programmable slope. The mute process can either be activated by the SoftMute pin or by the I<sup>2</sup>C bus. This slope is realized in a special S-shaped curve to mute slow in the critical regions (see [Figure 7](#)).

For timing purposes the bit 0 of the I<sup>2</sup>C bus output register is set to 1 from the start of muting until the end of demuting.

**Figure 7. SoftMute timing**

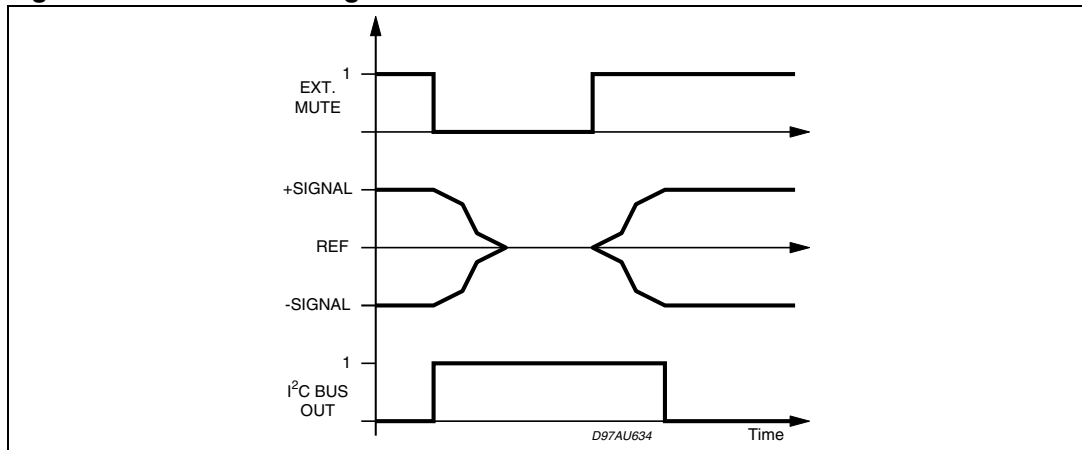

*Note:* Please notice that a started mute-action is always terminated and could not be interrupted by a change of the mute –signal.

### 4.4 SoftStep volume

When the volume-level is changed audible clicks could appear at the output. The root cause of those clicks could either be a DC-offset before the volume-stage or the sudden change of the envelope of the audio signal. With the SoftStep-feature both kinds of clicks could be reduced to a minimum and are no more audible. The blend-time from one step to the next is programmable as 5 ms or 10 ms. The SoftStep control is described in detail in [Chapter 4.9](#).

## 4.5 Bass

There are four parameters programmable in the bass stage:

### 4.5.1 Bass attenuation

Figure 8 shows the attenuation as a function of frequency at a center frequency of 80 Hz.

Figure 8. Bass control @  $f_c = 80$  Hz,  $Q = 1$

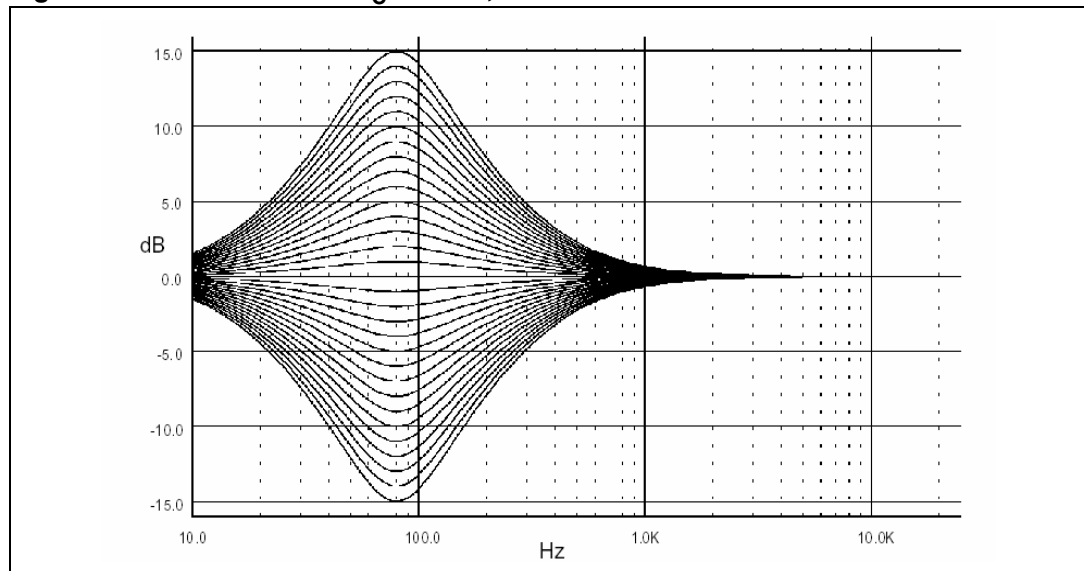

### 4.5.2 Bass center frequency

Figure 9 shows the four possible center frequencies 60, 80, 100 and 200 Hz.

Figure 9. Bass center frequencies @ gain = 14 dB,  $Q = 1$

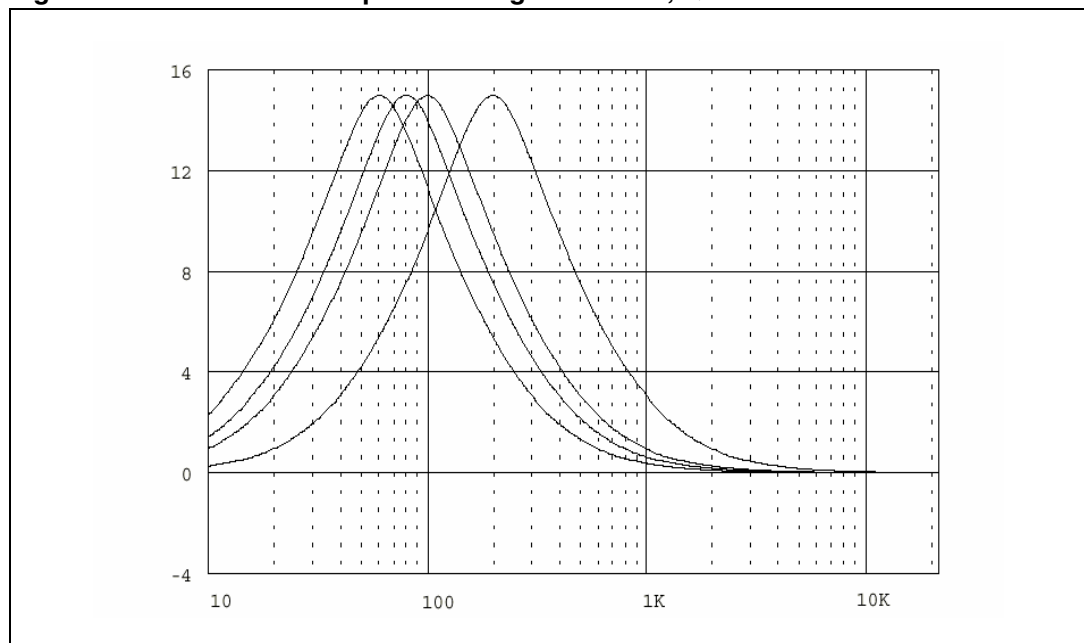

### 4.5.3 Quality factors

Figure 10 shows the four possible quality factors 1, 1.25, 1.5 and 2.

**Figure 10. Bass quality factors @ gain = 14 dB,  $f_C = 80$  Hz**

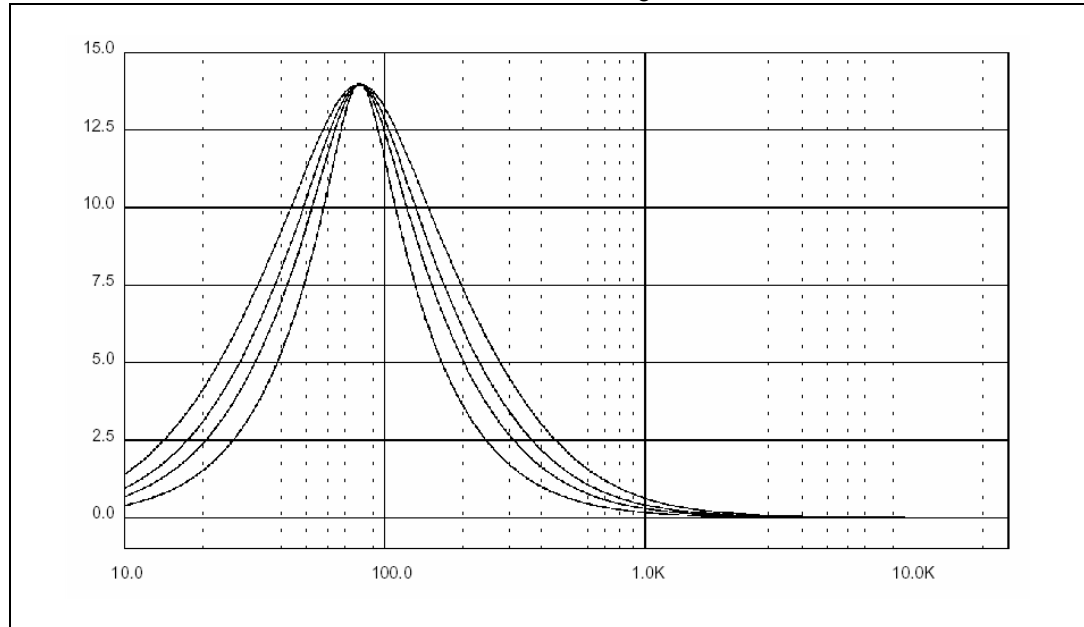

### 4.5.4 DC mode

In this mode the DC-gain is increased by 4.4 dB. In addition the programmed center frequency and quality factor is decreased by 25 % which can be used to reach alternative center frequencies or quality factors.

**Figure 11. Bass normal and DC mode @ gain = 14 dB,  $f_C = 80$  Hz**

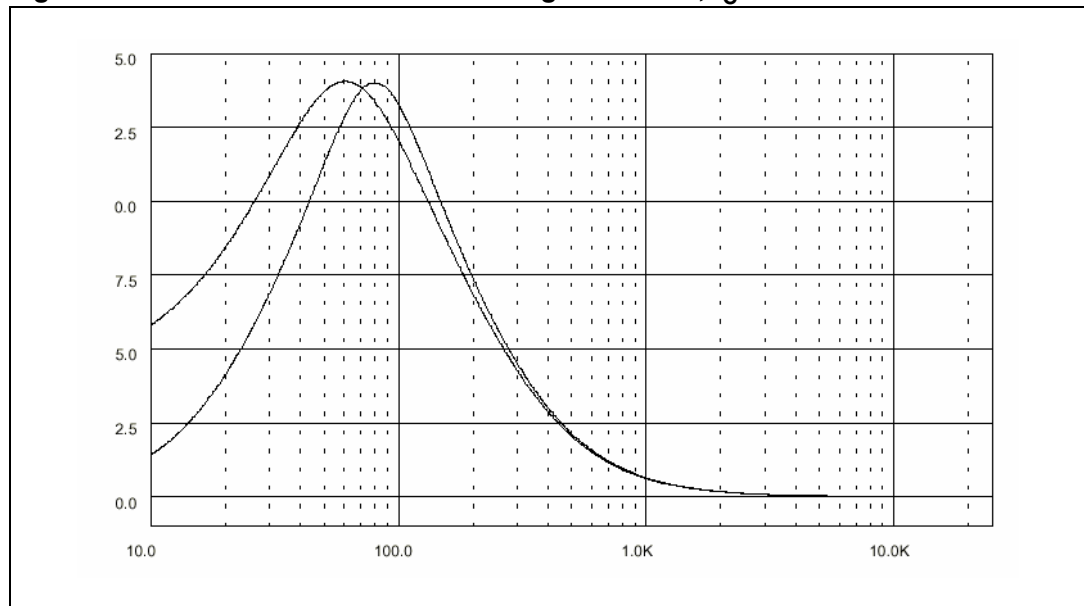

1. The center frequency, Q and DC-mode can be set fully independently.



## 4.6 Middle

There are three parameters programmable in the middle stage:

### 4.6.1 Middle attenuation

Figure 12 shows the attenuation as a function of frequency at a center frequency of 1 kHz.

Figure 12. Middle control @  $f_C = 1 \text{ kHz}$ ,  $Q = 1$

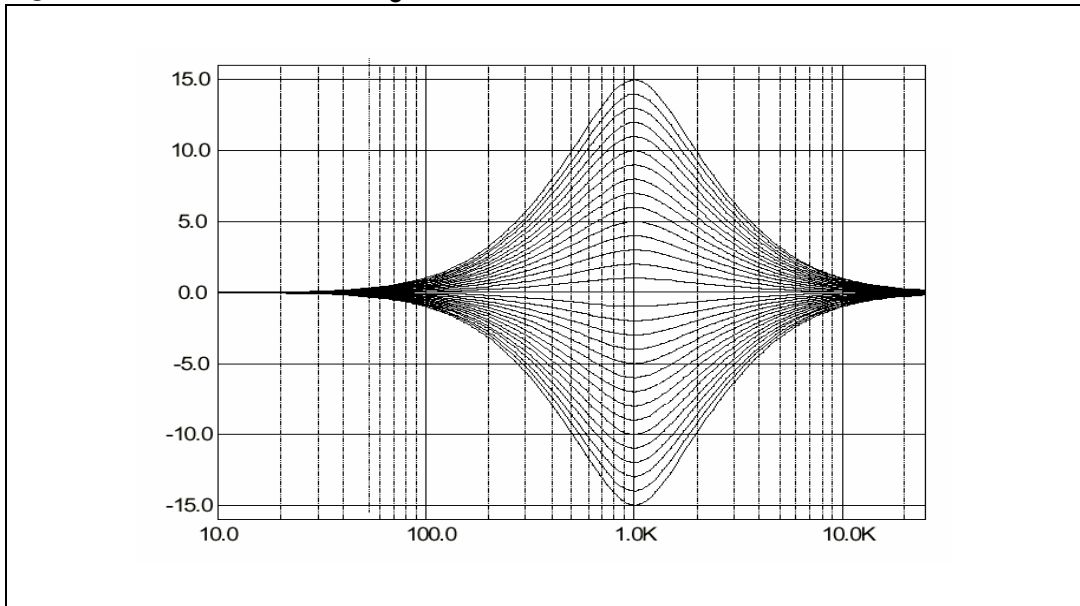

### 4.6.2 Middle center frequency

Figure 13 shows the four possible center frequencies 500 Hz, 1 kHz, 1.5 kHz and 2.5 kHz.

Figure 13. Middle center frequencies @ gain = 14 dB,  $Q = 1$

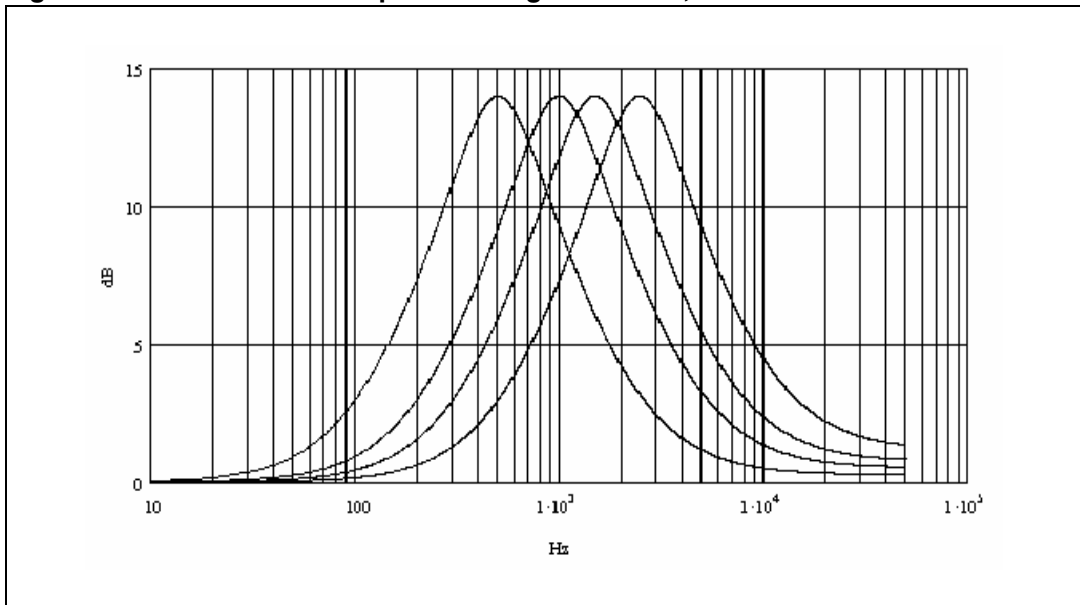

### 4.6.3 Quality factors

Figure 14 shows the three possible quality factors 0.75, 1 and 1.25.

Figure 14. Middle quality factors @ gain = 14 dB,  $f_C = 1$  kHz

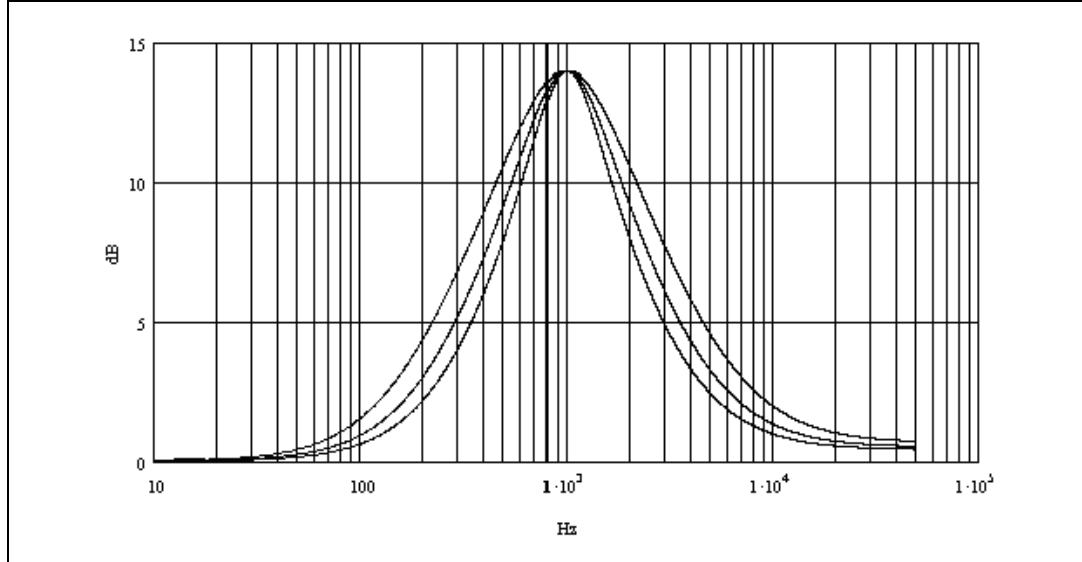

## 4.7 Treble

There are two parameters programmable in the treble stage:

### 4.7.1 Treble attenuation

Figure 15 shows the attenuation as a function of frequency at a center frequency of 17.5 kHz.

Figure 15. Treble control @  $f_C = 17.5$  kHz.

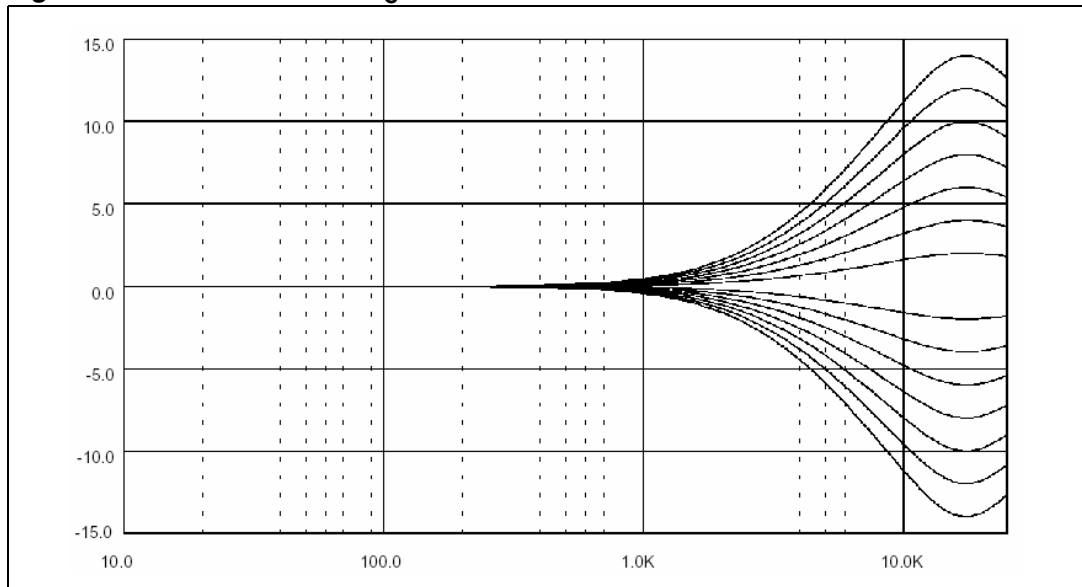

### 4.7.2 Center frequency

Figure 16 shows the four possible center frequencies 10 k, 12.5 k, 15 k and 17.5 kHz.

Figure 16. Treble center frequencies @ gain = 14 dB

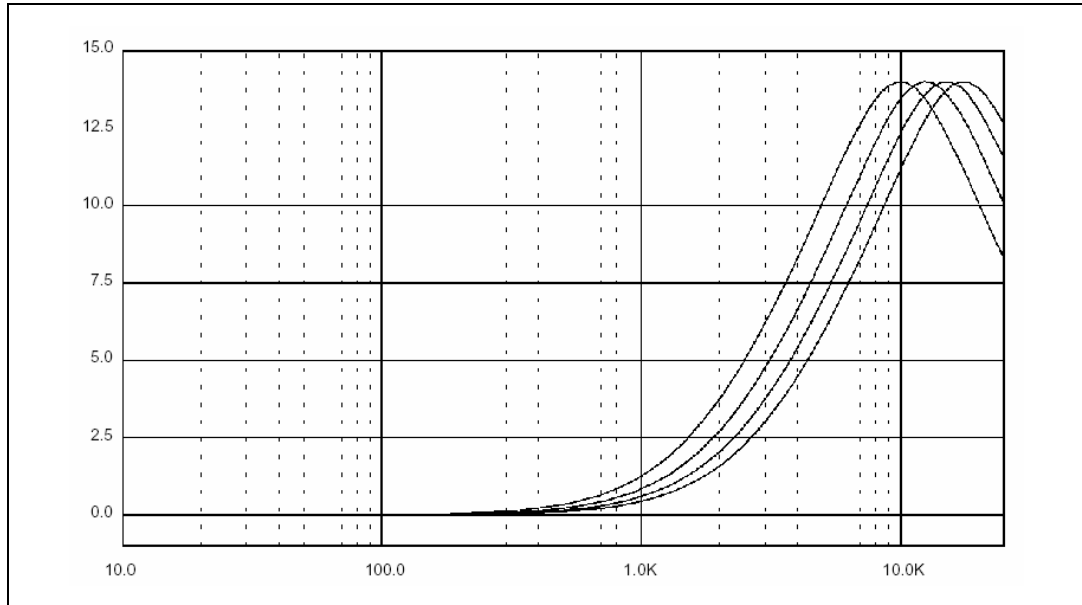

### 4.8 Subwoofer filter

The subwoofer lowpass filter has Butterworth characteristics with programmable cut-off frequency (55 Hz / 85 Hz / 120 Hz / 160 Hz). The output phase can be selected between 0 deg and 180 deg. The input of subwoofer takes signal from bass filter output or output of input mux.

Figure 17. Subwoofer cut frequencies

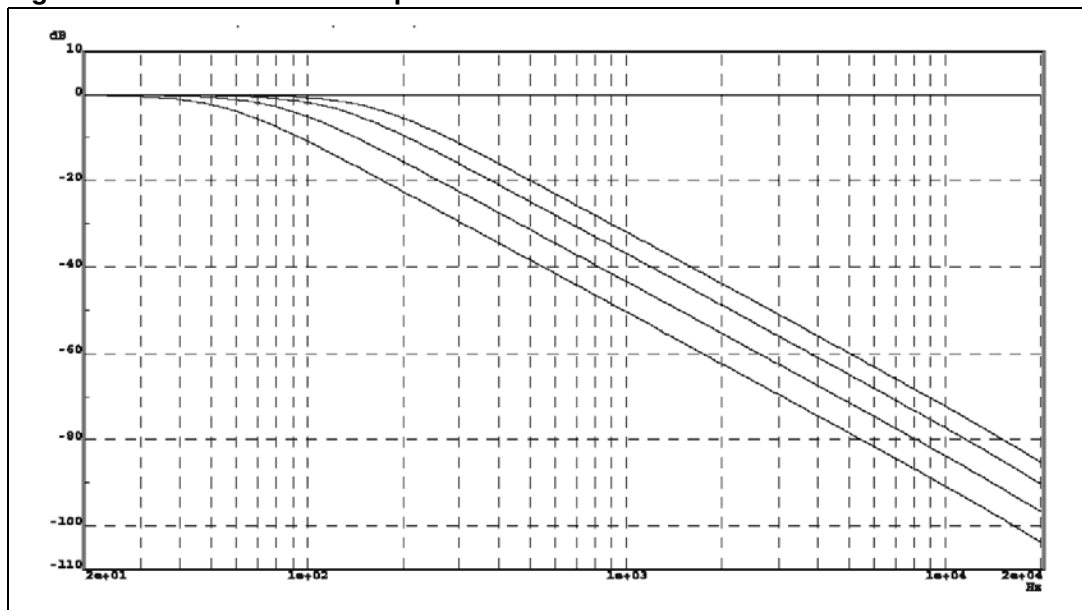

## 4.9 Softstep control

In this device, the softstep function is available for volume, speaker, loudness, treble, middle and bass block. With softstep function, the audible noise of DC offset or the sudden change of signal can be avoided when adjusting gain setting of the block.

For each block, the softstep function is controlled by softstep on/off control bit in the control table. The softstep transient time selection (5 ms or 10 ms) is common for all blocks and it is controlled by softstep time control bit. The softstep operation of all blocks has a common centralized control. In this case, a new softstep operation can not be started before the completion previous softstep.

There are two different modes to activate the softstep operation. The softstep operation can be started right after I<sup>2</sup>C data sending, or the softstep can be activated in parallel after data sending of several different blocks. The two modes are controlled by the 'act bit' (it is normally bit7 of the byte.) of each byte. When act bit is '0', which means action, the softstep is activated right after the date byte is sent. When the act bit is '1', which means wait, the block goes to wait for softstep status. In this case, the block will wait for some other block to activate the operation. The softstep operation of all blocks in wait status will be done together with the block which activate the softstep. With this mode, all specific blocks can do the softstep in parallel. This avoids waiting when the softstep is operated one by one.

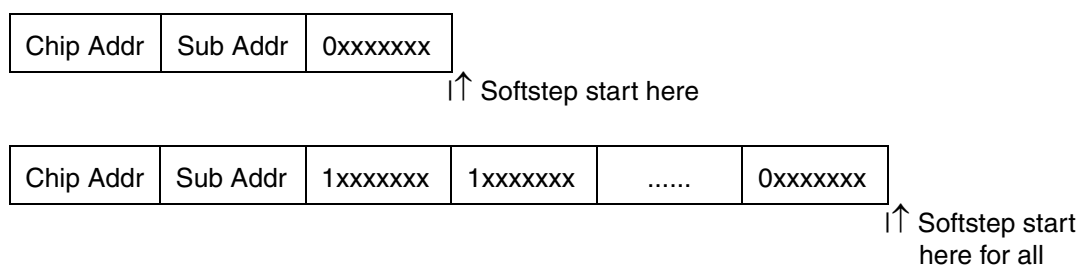

## 4.10 DC offset detector

Using the DC offset detection circuit ([Figure 18](#)) an offset voltage difference between the audio power amplifier and the APR's Front and Rear outputs can be detected, preventing serious damage to the loudspeakers. The circuit compares whether the signal crosses the zero level inside the audio power at the same time as in the speaker cell. The output of the zero-window-comparator of the power amplifier must be connected with the WinIn-input of the APR. The WinIn-input has an internal pull-up resistor connected to 5.5 V. It is recommended to drive this pin with open-collector outputs only.

To compensate for errors at low frequencies the WinTC-pin are implemented, with external capacitors introducing the same delay  $\tau = 7.5 \text{ k}\Omega * C_{\text{ext}}$  as the AC-coupling between the APR and the power amplifier introduces. For the zero window comparators, the time constant for spike rejection as well as the threshold are programmable.

For electrical characteristics see [Chapter 3 on page 9](#).

A low-active DC-offset error signal appears at the DCErr output if the next conditions are both true:

- a) Front and rear outputs are inside zero crossing windows.
- b) The Input voltage VWinIn is logic low whenever at least one output of the power amplifier is outside the zero crossing windows.

After power-on, the external attached capacitor is rapidly charged (fast-charge) to overcome a false indication.

Figure 18. DC offset detection circuit (simplified)

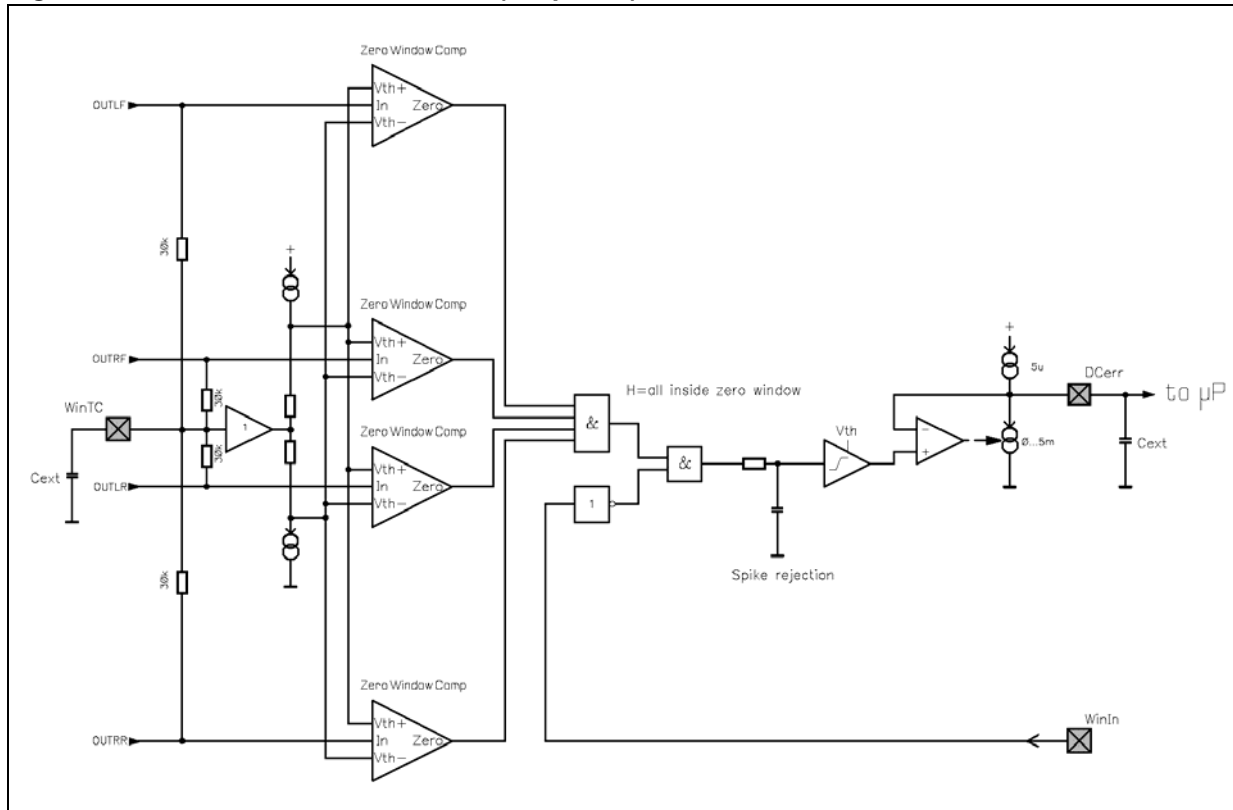

### 4.11 Audioprocessor testing

In the test mode, which can be activated by setting bit D7 of the I<sup>2</sup>C subaddress byte and bit D0 of the testing audioprocessor byte, several internal signals are available at the SE1L pin. In this mode, the input resistance of 100 kΩ is disconnected from the pin. Internal signals available for testing are listed in the data-byte specification.

Figure 19. Test circuit

