



Chipsmall Limited consists of a professional team with an average of over 10 year of expertise in the distribution of electronic components. Based in Hongkong, we have already established firm and mutual-benefit business relationships with customers from,Europe,America and south Asia,supplying obsolete and hard-to-find components to meet their specific needs.

With the principle of “Quality Parts,Customers Priority,Honest Operation,and Considerate Service”,our business mainly focus on the distribution of electronic components. Line cards we deal with include Microchip,ALPS,ROHM,Xilinx,Pulse,ON,Everlight and Freescale. Main products comprise IC,Modules,Potentiometer,IC Socket,Relay,Connector.Our parts cover such applications as commercial,industrial, and automotives areas.

We are looking forward to setting up business relationship with you and hope to provide you with the best service and solution. Let us make a better world for our industry!



## Contact us

Tel: +86-755-8981 8866 Fax: +86-755-8427 6832

Email & Skype: info@chipsmall.com Web: www.chipsmall.com

Address: A1208, Overseas Decoration Building, #122 Zhenhua RD., Futian, Shenzhen, China



# TDA8931

Power comparator 1 × 20 W

Rev. 01 — 14 January 2004

Preliminary data sheet

## 1. General description

The TDA8931 is a switching power stage for high efficiency class-D audio power amplifier systems.

It contains a Single-Ended (SE) power stage, drive logic, protection control logic, a full differential input comparator and a HVP charger to charge the SE capacitor. With this amplifier a compact 1 × 20 W closed loop self-oscillating digital amplifier system can be built. The TDA8931 has a high efficiency so that a heat sink is not required up to 20 W (RMS). The system operates on an asymmetrical and a symmetrical supply voltage.

## 2. Features

- High efficiency
- Operating voltage asymmetrical from 12 V to 35 V
- Operating voltage symmetrical from  $\pm 6$  V to  $\pm 17.5$  V
- Thermally protected
- No heat sink required
- Charger for single-ended capacitor
- No pop sound

## 3. Applications

- Flat panel television sets
- Flat panel monitors
- Multimedia systems
- Wireless speakers
- Micro systems

## 4. Quick reference data

Table 1: Quick reference data

Symbol	Parameter	Conditions	Min	Typ	Max	Unit
<b>General</b>						
$V_P$	operating supply voltage	asymmetrical	12	22	35	V
		symmetrical	$\pm 6$	$\pm 11$	$\pm 17.5$	V
$I_q$	quiescent current	Operating mode; $V_P = 22$ V	-	20	30	mA
$I_{stb}$	standby current	Standby mode; $V_P = 22$ V	-	10	15	mA
$I_{sleep}$	sleep current	Sleep mode; $V_P = 22$ V	-	100	200	$\mu$ A

**PHILIPS**

Table 1: Quick reference data ...continued

Symbol	Parameter	Conditions	Min	Typ	Max	Unit
$\eta$	efficiency	$P_o = 15 \text{ W}; V_p = 30 \text{ V};$ $R_L = 8 \Omega$	89	91	-	%
<b>SE channel</b>						
$P_o$	maximum output power	$R_L = 4 \Omega; \text{THD} = 10 \%$				
		$V_p = 26 \text{ V}$	21	22	-	W
		$V_p = 22 \text{ V}$	15	16	-	W
		$R_L = 8 \Omega; \text{THD} = 10 \%$				
		$V_p = 30 \text{ V}$	15	16	-	W

## 5. Ordering information

Table 2: Ordering information

Type number	Package		
	Name	Description	Version
TDA8931T	SO20	plastic small outline package; 20 leads; body width 7.5 mm	SOT163-1

6. Block diagram

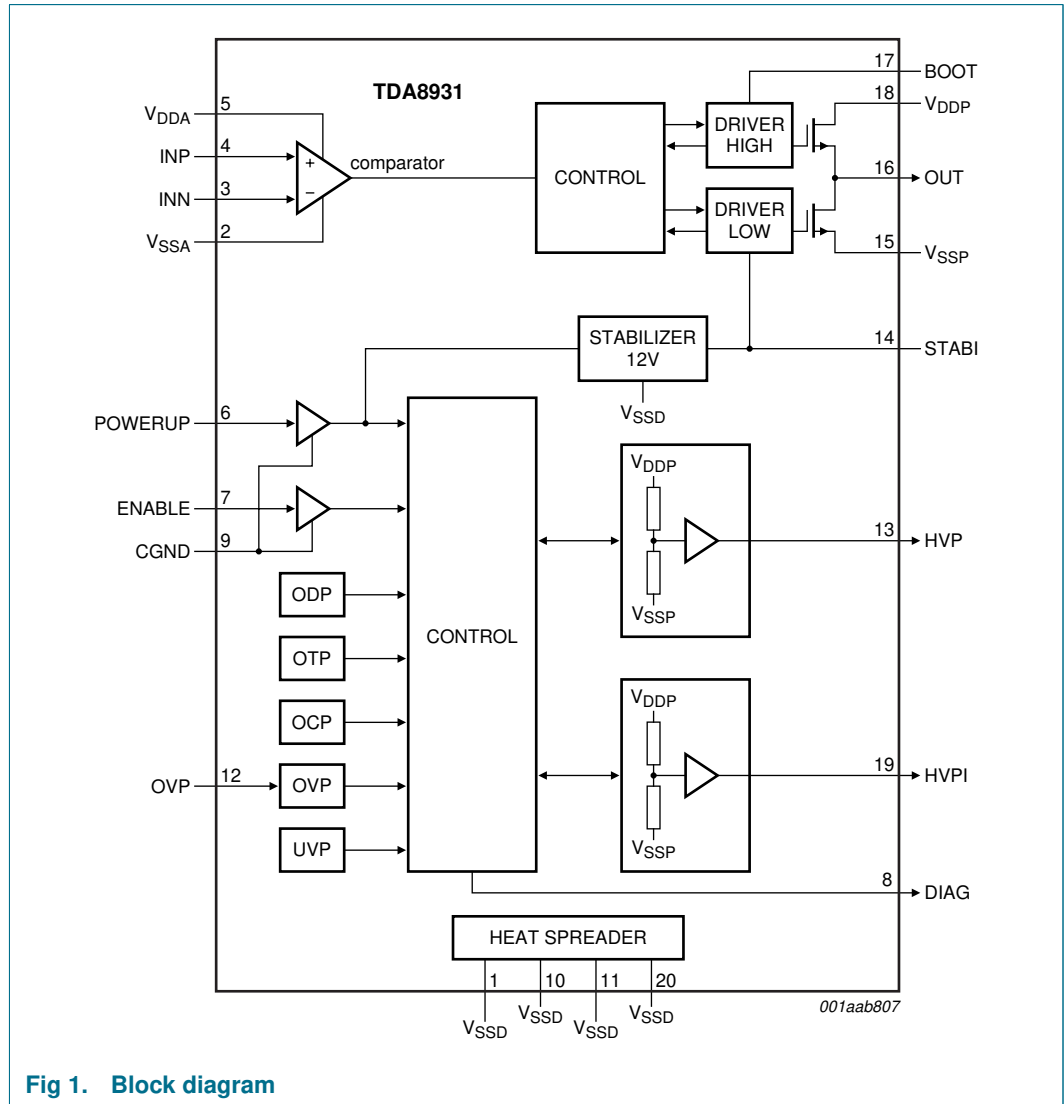

Fig 1. Block diagram

## 7. Pinning information

### 7.1 Pinning

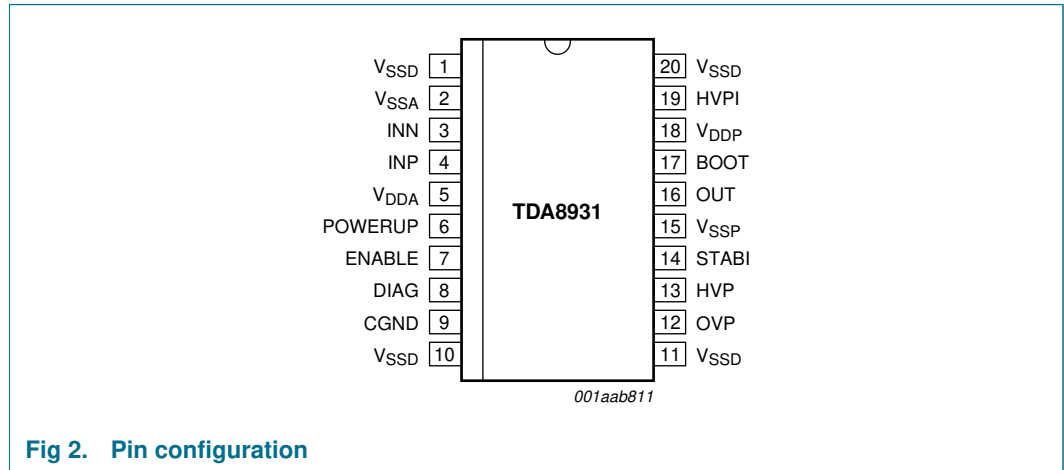

Fig 2. Pin configuration

### 7.2 Pin description

Table 3: Pin description

Symbol	Pin	Description
V <sub>SSD</sub>	1	negative digital supply voltage; heat spreader
V <sub>SSA</sub>	2	negative analog supply voltage
INN	3	inverting input
INP	4	non inverting input
V <sub>DDA</sub>	5	positive analog supply voltage
POWERUP	6	power-up input
ENABLE	7	enable input
DIAG	8	diagnostic output
CGND	9	control ground; reference ground for pins POWERUP, ENABLE and DIAG
V <sub>SSD</sub>	10	negative digital supply voltage; heat spreader
V <sub>SSD</sub>	11	negative digital supply voltage; heat spreader
OVP	12	overvoltage protection reference input
HVP	13	half supply voltage output for charging SE capacitor
STABI	14	decoupling of internal stabilizer
V <sub>SSP</sub>	15	negative power supply voltage
OUT	16	PWM output
BOOT	17	bootstrap capacitor connection
V <sub>DDP</sub>	18	positive power supply voltage
HVPI	19	half supply voltage output for reference voltage of input circuitry
V <sub>SSD</sub>	20	negative digital supply voltage; heat spreader

## 8. Functional description

### 8.1 General

The TDA8931 is a switching power stage for high efficiency class-D audio power amplifier systems. It contains a Single-Ended (SE) power stage, drive logic, protection control logic, a full differential input comparator and a HVP charger to charge the SE capacitor (see [Figure 1](#)). With this amplifier a compact 1 × 20 W closed loop self-oscillating digital amplifier system can be built. A second order low-pass filter converts the PWM output signal into an analog audio signal across the speaker.

### 8.2 Interfacing

The operating modes of the TDA8931 can be controlled by pins POWERUP and ENABLE. Both pins refer to pin CGND. The device has three modes:

- Sleep mode
- Standby mode
- Operating mode

When pin POWERUP = LOW, the power comparator is in Sleep mode, independent of the signal on pin ENABLE. In Sleep mode the SE capacitor charger will be discharged.

When pin POWERUP = HIGH and pin ENABLE = LOW the device is in Standby mode. In Standby mode the device is DC biased and the SE capacitor will be charged and the output is floating.

When both pins POWERUP and ENABLE are HIGH, the device is in Operating mode. A level at pin POWERUP greater than 11 V can also enter the Operating mode, independent of the level on pin ENABLE (see [Table 4](#)).

**Remark:** The switch-on sequence is important. First pin POWERUP = HIGH, then pin ENABLE = HIGH.

**Table 4: Interfacing**

Voltage on pin		Mode
POWERUP	ENABLE	
< 0.8 V	-	Sleep
3 V to 7 V	< 0.8 V	Standby
	> 3 V	Operating
> 11 V	-	Operating

### 8.3 Input comparator

The input comparator has a full differential input and is optimized for low noise and low offset. This results in maximum flexibility in the application.

### 8.4 Half supply voltage input reference (pin HVPI)

When the device is in Standby mode, the external capacitor C6 (see [Figure 5](#)) will be charged until it reaches the half of the supply voltage. This pin charges capacitor C6 within 0.5 seconds.

Pin HVPI will be on its final level of  $0.5V_P$  before the device starts switching. This results into a plop-noise free start-up behavior.

### 8.5 Half supply voltage capacitor charger (pin HVP)

When the device is in Standby mode, the SE capacitor C15 (see [Figure 5](#)) will be charged until it reaches the half of the supply voltage. This current charges capacitor C15 within 0.5 seconds when a capacitor of 1000  $\mu\text{F}$  is used. When the voltage on pin HVP has reached the level of  $0.5V_P$  it releases pin ENABLE for external use.

When the device is in Operating mode, pin HVP is switched to floating to minimize dissipation.

When the supply voltage drops, capacitor C15 is discharged and the device is switched off to avoid plop noise.

### 8.6 Protections

Overtemperature, overcurrent, overvoltage and undervoltage sensors are included in the TDA8931. When one of these sensors exceeds its threshold level the output power stage is switched off and the output stage becomes floating. After 1.5  $\mu\text{s}$  the device will try to restart. When the fault condition is removed the output stage is switched on.

Table 5: Overview protections

Protection		Output pin DIAG	Remark
Symbol	Condition		
OTP	$T_j > 150\text{ }^\circ\text{C}$	LOW [1]	self recovering when fault is removed
OCP	$I_O > I_{OCP}$		
OVP	$V_P > V_{P(OVP)fix}$		
UVP	$V_P < V_{P(UVP)}$		
ODP	$I_O > I_{OCP}$ and $T_j > 140\text{ }^\circ\text{C}$	LOW	recovering by switching pin POWERUP: first to Sleep mode and then to Standby mode recovering by removing supply voltage

[1] Pin DIAG = LOW for minimal 1.5  $\mu\text{s}$ .

#### 8.6.1 Overtemperature protection (OTP)

If the junction temperature  $T_j$  exceeds the threshold level of approximately  $150\text{ }^\circ\text{C}$  then the device will shut down immediately. The device will start switching again when the temperature drops.

#### 8.6.2 Overcurrent protection (OCP)

If the output current exceeds the maximum output current threshold level (e.g. when the loudspeaker terminals are short-circuited it will be detected by the current protection) the device will shut-down.

#### 8.6.3 Overvoltage protection (OVP)

When the supply voltage applied to the TDA8931 exceeds the maximum supply voltage threshold level the device will shut down. The supply voltage on which the device stops operating is determined by two external resistors R1 and R2.

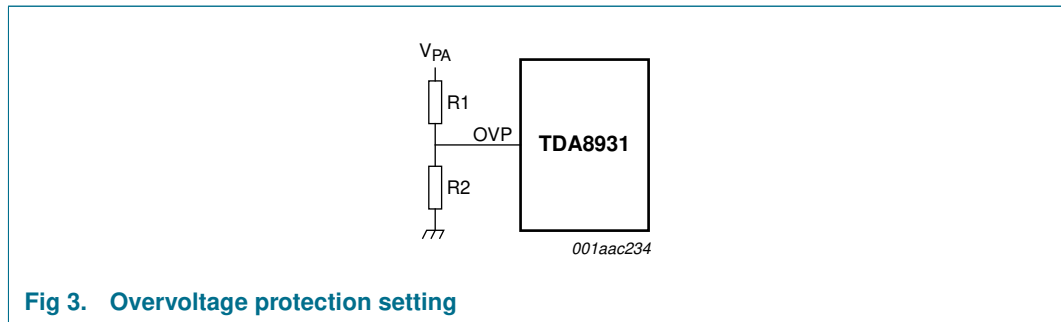

Fig 3. Overvoltage protection setting

The overvoltage protection level can be determined by the formula:

$$V_{P(OVP)} = \frac{R1 + R2}{R2} \times V_{OVP} \quad (1)$$

Where:

$V_{P(OVP)}$  = overvoltage protection level of supply voltage

R1 = external resistor

R2 = external resistor

$V_{OVP}$  = 1.27 V reference voltage.

**Example:** The TDA8931 has to shut down at 24 V. When we choose R2 = 10 kΩ, then R1 has to be 178 kΩ and  $V_{P(OVP)}$  becomes 24 V.

**Remark:** When pin OVP is connected to  $V_{SSD}$  the  $V_{P(OVP)fix}$  level is used.

### 8.6.4 Undervoltage protection (UVP)

When the supply voltage applied to the TDA8931 drops below the minimum supply voltage threshold level the device is internally set to Standby mode.

### 8.6.5 Supply voltage drop protection

When the TDA8931T is switched off with the supply, it will be switched off before it reaches the voltage on pin HVP. This prevents switch-off pop noise. This function is not self recovering. The TDA8931T can be recovered by switching to Sleep mode or by removing the supply voltage.

### 8.6.6 Overdissipation protection (ODP)

In case of a short-circuit across the speaker the dissipation is minimized by the ODP. When the OCP and the OTP are on the same time activated, an over dissipation is defined. The device is set to Sleep mode and is not self-recovering. When pin POWERUP = 0 V or the supply voltage is removed, the device is recovered.



9. Internal circuitry

Table 6: Internal circuitry

Pin	Symbol	Equivalent circuit
1, 10, 11, 20	V <sub>SSD</sub>	<p>001aab815</p>
2	V <sub>SSA</sub>	<p>001aab817</p>
3, 4	INN, INP	<p>001aab816</p>
5	V <sub>DDA</sub>	<p>001aab818</p>
6	POWERUP	<p>001aab819</p>

Table 6: Internal circuitry ...continued

Pin	Symbol	Equivalent circuit
7	ENABLE	
8	DIAG	
9	CGND	
12	OVP	
13	HVP	
14	STABI	

Table 6: Internal circuitry ...continued

Pin	Symbol	Equivalent circuit
15	$V_{SSP}$	<p>001aab826</p>
16	OUT	
18	$V_{DDP}$	
17	BOOT	<p>001aab827</p>
19	HVPI	<p>001aab828</p>

## 10. Limiting values

**Table 7: Limiting values**

In accordance with the Absolute Maximum Rating System (IEC 60134).

Symbol	Parameter	Conditions	Min	Max	Unit
V <sub>P</sub>	operating supply voltage	asymmetrical	12	40	V
		symmetrical	±6	±20	V
V <sub>ENABLE</sub>	maximum voltage on pin ENABLE		-	14	V
V <sub>OVP</sub>	maximum voltage on pin OVP		-	14	V
V <sub>n</sub>	voltage on all other pins		V <sub>SS</sub> - 0.3	V <sub>DD</sub> + 0.3	V
I <sub>ORM</sub>	repetitive peak output current		-	8	A
P <sub>d(max)</sub>	maximum power dissipation		-	2.5	W
T <sub>j</sub>	junction temperature		-	150	°C
T <sub>stg</sub>	storage temperature		-55	+150	°C
T <sub>amb</sub>	ambient temperature		-40	+85	°C

## 11. Thermal characteristics

**Table 8: Thermal characteristics**

Symbol	Parameter	Conditions	Typ	Unit
R <sub>th(j-a)</sub>	thermal resistance junction to ambient	in free air	[1] 24	K/W
R <sub>th(j-p)</sub>	thermal resistance junction to pin	in free air	[2] 16	K/W
R <sub>th(j-c)</sub>	thermal resistance junction to case	in free air	[3] 3	K/W

[1] Measured in the application board.

[2] V<sub>p</sub> = 22 V; R<sub>L</sub> = 4 Ω; V<sub>ripple</sub> = 2 V (p-p); f<sub>ripple</sub> = 100 Hz with feed-forward network (470 kΩ and 15 nF).

[3] Strongly depending on where you measure on the case.

## 12. Static characteristics

**Table 9: Characteristics**

V<sub>P</sub> = 22 V; T<sub>amb</sub> = 25 °C; f<sub>carrier</sub> = 290 kHz; unless otherwise specified.

Symbol	Parameter	Conditions	Min	Typ	Max	Unit
<b>Supply voltage</b>						
V <sub>P</sub>	operating supply voltage	V <sub>P</sub> = V <sub>DDP</sub> - V <sub>SSP</sub>				
		asymmetrical	12	22	35	V
		symmetrical	±6	±11	±17.5	V
I <sub>q</sub>	quiescent current	with load; filter and snubbers connected	-	20	30	mA
I <sub>stb</sub>	standby current	Standby mode; SE capacitor charged	-	10	15	mA
I <sub>sleep</sub>	sleep current	Sleep mode	-	100	200	µA

**Table 9: Characteristics ...continued** $V_P = 22\text{ V}$ ;  $T_{amb} = 25\text{ °C}$ ;  $f_{carrier} = 290\text{ kHz}$ ; unless otherwise specified.

Symbol	Parameter	Conditions	Min	Typ	Max	Unit
<b>Power-up input: pin POWERUP</b>						
$V_{IL}$	LOW-level input voltage	with respect to CGND	-	-	0.8	V
$V_{IH}$	HIGH-level input voltage	with respect to CGND				
		Standby mode	3	-	7	V
		Operating mode	11	-	$V_P$	V
$V_{hys}$	hysteresis voltage		-	0.5	-	V
$I_I$	input current	$V_I = 5\text{ V}$	-	30	40	$\mu\text{A}$
<b>Enable input: pin ENABLE</b>						
$V_{IL}$	LOW-level input voltage	with respect to CGND	-	-	0.8	V
$V_{IH}$	HIGH-level input voltage	with respect to CGND	[1] 3	-	12	V
$V_{hys}$	hysteresis voltage		-	0.3	-	V
$I_I$	input current	$V_I = 5\text{ V}$	-	30	40	$\mu\text{A}$
<b>Internal stabilizer output: pin STABI</b>						
$V_O$	output voltage	with respect to $V_{SSD}$	11	12	14	V
<b>Comparator full differential input stage: pins INP and INN</b>						
$V_{off(i)(eq)}$	equivalent input offset voltage		-	-	10	mV
$V_{n(i)(eq)}$	equivalent input RMS-noise voltage	$20\text{ Hz} < f_i < 20\text{ kHz}$	-	-	15	mV
$V_{i(cm)}$	common mode input voltage		$V_{SSA} + 4$	-	$V_{DDA} - 5$	V
$I_{i(bias)}$	bias input current		-	24	60	nA
<b>Half supply voltage output for input circuitry: pin HVPI</b>						
$V_{HVPI}$	output voltage on pin HVPI	Standby and Operating mode	$0.5V_P - 0.25$	$0.5V_P$	$0.5V_P + 0.25$	V
<b>Half supply voltage output to charge SE capacitor: pin HVP</b>						
$V_{HVP}$	output voltage on pin HVP	Standby mode	$0.5V_P - 0.25$	$0.5V_P$	$0.5V_P + 0.25$	V
$I_{charge}$	charge current of HVP capacitor		20	45	-	mA
<b>Overtemperature protection (OTP)</b>						
$T_{OTP}$	overtemperature protection level		150	155	-	$^{\circ}\text{C}$
<b>Overvoltage protection (OVP)</b>						
$V_{P(OVP)fix}$	fixed OVP threshold level	level internal fixed	35	37.5	40	V
$V_{OVP}$	adjustable OVP level		[2] 1.19	1.27	1.35	V
<b>Undervoltage protection (UVP)</b>						
$V_{P(min)}$	protection level minimum supply voltage		10	11	12	V
<b>Overcurrent protection (OCP)</b>						
$I_{OCP}$	overcurrent protection level		3.3	4.0	-	A

[1]  $V_{IH}$  on pin ENABLE must not exceed  $V_{DDA}$ .[2] The overvoltage protection can be controlled external (see [Section 8.6.3](#)).

### 13. Dynamic characteristics

**Table 10: Characteristics**
 $V_P = 22\text{ V}$ ;  $T_{amb} = 25\text{ °C}$ ;  $R_L = 4\ \Omega$ ; unless otherwise specified.

Symbol	Parameter	Conditions	Min	Typ	Max	Unit	
<b>Amplifier; SE channel</b>							
$P_{O(max)}$	maximum output power	$R_L = 4\ \Omega$ ; THD = 10 %	[1]				
		$V_P = 26\text{ V}$	21	22	-	W	
		$V_P = 22\text{ V}$	15	16	-	W	
		$R_L = 8\ \Omega$ ; THD = 10 %					
		$V_P = 30\text{ V}$	15	16	-	W	
THD	total harmonic distortion	$P_O = 1\text{ W}$ , $f_i = 1\text{ kHz}$	[1]	-	0.02	0.1	%
$V_{n(o)}$	noise output voltage	Operating mode; inputs shorted; gain = 20 dB, AES17 brick wall filter	[1]	-	128	150	$\mu\text{V}$
$G_{v(range)}$	gain adjust range		[1]	14	20	26	dB
$\eta$	efficiency	$P_O = 15\text{ W}$					
		$V_P = 22\text{ V}$ ; $R_L = 4\ \Omega$	[1]	87	89	-	%
		$V_P = 30\text{ V}$ ; $R_L = 8\ \Omega$	[1]	89	91	-	%
<b>PWM output: pin OUT (see Figure 4)</b>							
$t_r$	output voltage rise time		-	20	-	ns	
$t_f$	output voltage fall time		-	20	-	ns	
$t_{dead}$	dead time		-	0	-	ns	
$t_{r(LH)}$	response time of transition from LOW-to-HIGH	$V_{i(dif)} = 70\text{ mV}$	-	120	-	ns	
		$V_{i(dif)} = 3.3\text{ V}$	-	100	-	ns	
$t_{r(HL)}$	response time of transition from HIGH-to-LOW	$V_{i(dif)} = 70\text{ mV}$	-	120	-	ns	
		$V_{i(dif)} = 3.3\text{ V}$	-	100	-	ns	
$t_{W(min)}$	minimum pulse width		-	150	-	ns	
$R_{DSon}$	drain-source on-state resistance of output transistor		-	0.22	0.3	$\Omega$	

[1] Measured in the application board.

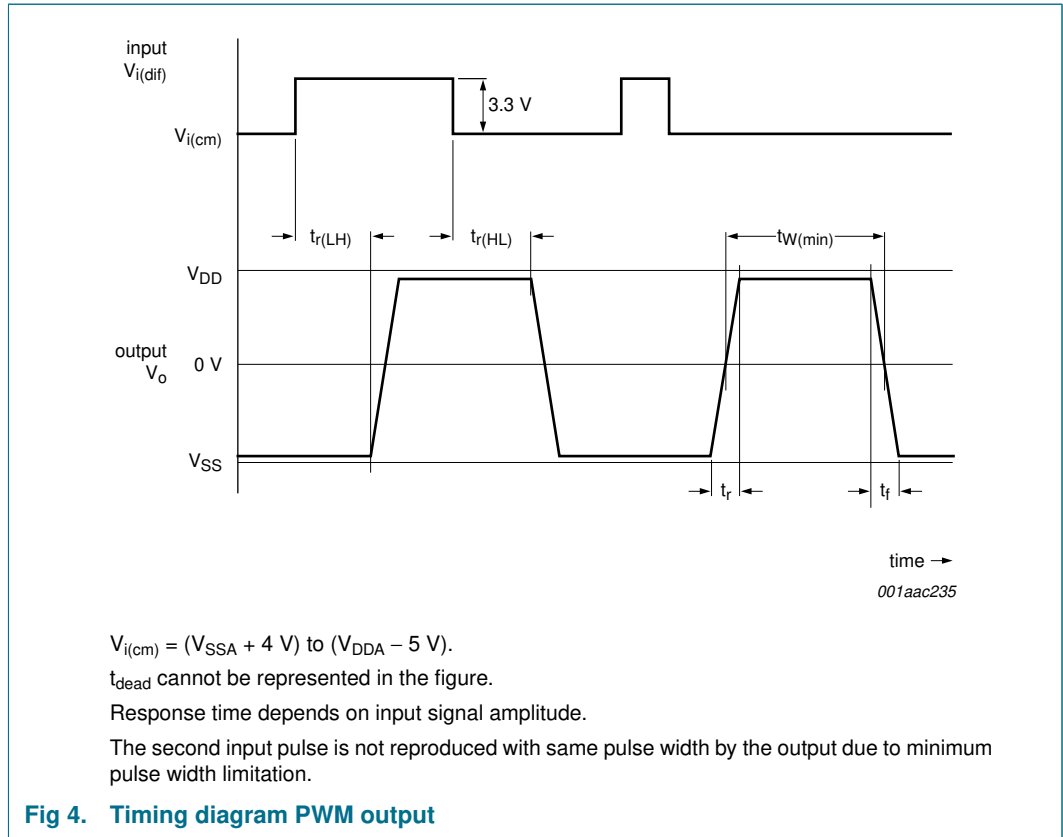

14. Application information

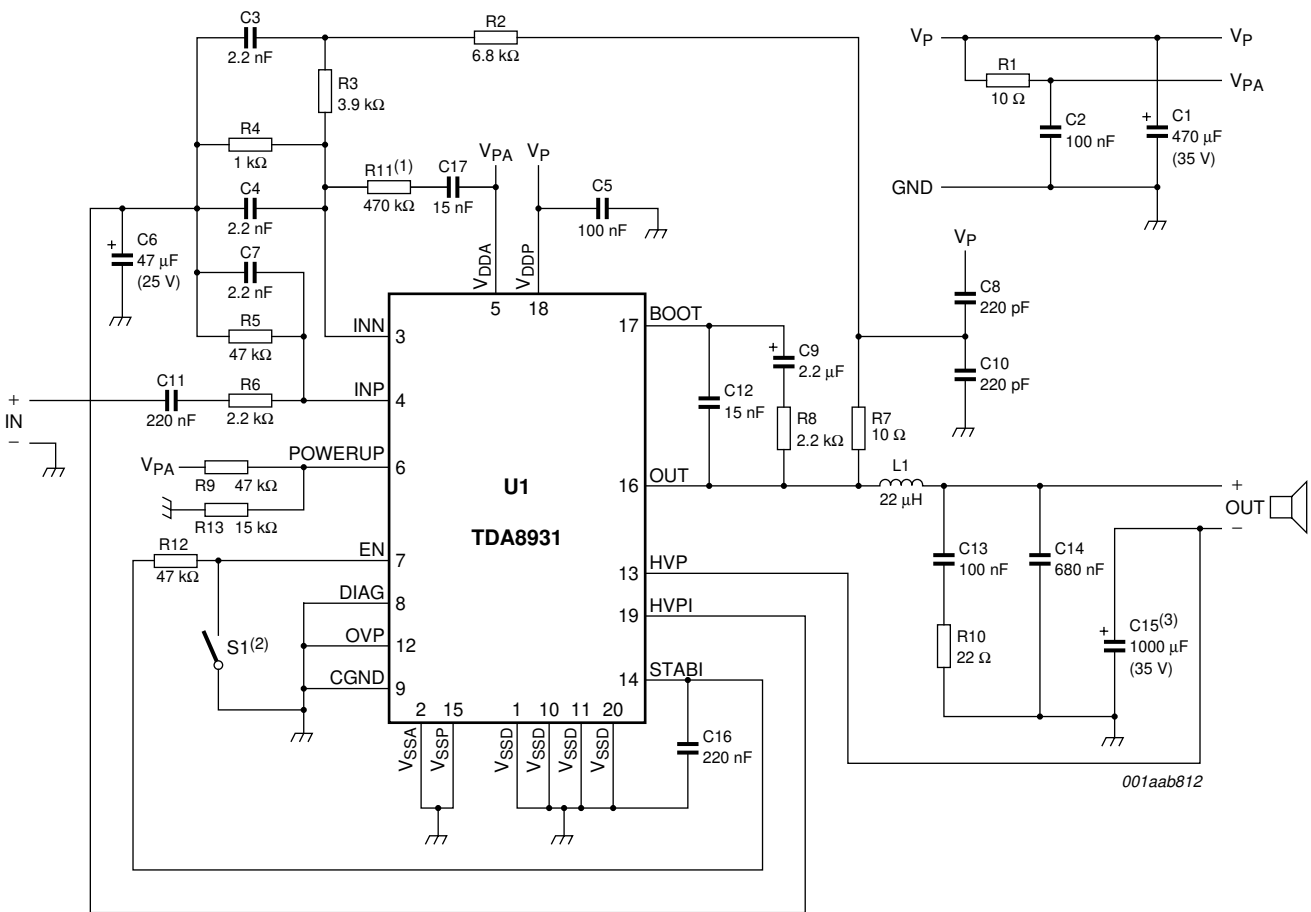

- (1) Optional feed forward network to improve SVRR.
- (2) Standby mode: S1 = closed; Operating mode: S1 = open.
- (3) The low frequency gain is determined by the capacitor in series with the speaker. The cut-off frequency with a 4 Ω speaker and C15 = 1000 μF is 40 Hz.

Fig 5. Typical application diagram with TDA8931 supplied from an asymmetrical supply



Table 11: Bill of material

Item	Part	Description
C1	470 $\mu$ F/35 V	general purpose
C2	100 nF	SMD 0805
C3	2.2 nF	SMD 0805
C4	2.2 nF	SMD 0805
C5	100 nF	SMD 0805
C6	47 $\mu$ F/25 V	general purpose
C7	2.2 nF	SMD 0805
C8	220 pF	SMD 0805
C9	2.2 $\mu$ F/16 V	general purpose
C10	220 pF	SMD 0805
C11	220 nF	SMD 1206
C12	15 nF	SMD 0805
C13	100 nF	SMD 0805
C14	680 nF	MKT
C15	1000 $\mu$ F/35 V	general purpose
C16	220 nF	SMD 1206
C17	15 nF	SMD 0805
R1	10 $\Omega$	SMD 1206
R2	6.8 k $\Omega$	SMD 0805
R3	3.9 k $\Omega$	SMD 0805
R4	1 k $\Omega$	SMD 0805
R5	47 k $\Omega$	SMD 0805
R6	2.2 k $\Omega$	SMD 0805
R7	10 $\Omega$	SMD 1206
R8	2.2 k $\Omega$	SMD 0805
R9	47 k $\Omega$	SMD 0805
R10	22 $\Omega$	SMD 2512
R11	470 k $\Omega$	SMD 0805
R12	47 k $\Omega$	SMD 0805
R13	15 k $\Omega$	SMD 0805
L1	22 $\mu$ H	TOKO 11RHBP A7503CY-220M
U1	TDA8931	SO20

### 14.1 Output power estimation

The output power, just before clipping, can be estimated using the following equation:

$$P_{o(1\%)} = \frac{\left( \frac{R_L}{R_L + R_{DSon} + R_{coil} + R_{ESR}} \times V_P \right)^2}{8 \times R_L} \tag{2}$$

Where:

$P_{o(1\%)}$  = output power just before clipping at THD = 1 %

$R_L$  = load impedance

$R_{DSon}$  = on-resistance power switch

$R_{coil}$  = series resistance output coil

$R_{ESR}$  = ESR of the single-ended capacitor

$V_P$  = supply voltage ( $V_{DDP} - V_{SSP}$ )

**Example:** Substituting  $R_L = 4 \Omega$ ,  $R_{DSon} = 0.22 \Omega$  (at  $T_j = 25 \text{ }^\circ\text{C}$ ),  $R_{coil} = 0.045 \Omega$ ,  $R_{ESR} = 0.06 \Omega$  and  $V_P = 22 \text{ V}$  results in output power  $P_o = 12.9 \text{ W}$ .

The output power at THD = 10 % can be estimated by:

$$P_{o(10\%)} = 1.25 \times P_{o(1\%)} \tag{3}$$

Figure 6 shows the estimated output power as a function of the supply voltage for different load impedances.

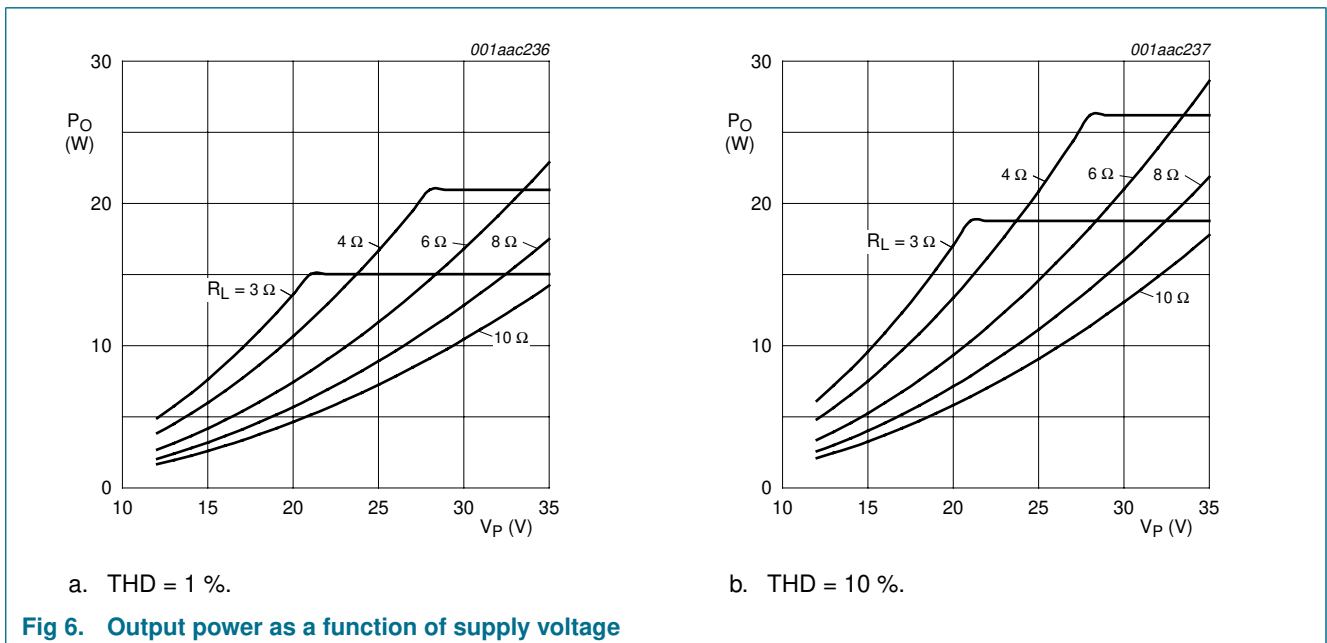

## 14.2 Output current limiting

The output current is limited by the OCP with a threshold level of 3.3 A (minimum). During normal operation the output current should not exceed this threshold level, otherwise the output signal is distorted. The peak output current should stay below 3.3 A and can be estimated using the following equation:

$$I_O \leq \frac{V_P}{2 \times (R_{DSon} + R_L + R_{coil} + R_{ESR})} \leq 3.3 \quad (4)$$

Where:

$I_O$  = output current in the load in

$V_P$  = supply voltage ( $V_{DDP} - V_{SSP}$ )

$R_{DSon}$  = on-resistance power switch

$R_L$  = load impedance

$R_{coil}$  = series resistance output coil

$R_{ESR}$  = ESR of the single-ended capacitor

**Example:** With a 4 Ω load the OCP will be triggered below a supply voltage of 28 V. This will result in an absolute maximum output power of  $P_o = 26$  W at THD = 10 %.

## 14.3 Low pass filter considerations

For a flat frequency response (second order Butterworth filter) it is necessary to change the LC-filter components (L1 and C14) according to the speaker impedance. [Table 12](#) shows the required components values in case of a 4 W, 6 W or 8 W speaker impedance.

**Table 12: Filter components values**

Speaker impedance (Ω)	L1 value (μH)	C14 value (nF)
4	22	680
6	33	470
8	47	330

## 14.4 Thermal behavior (printed-circuit board considerations)

The SO20 package of the TDA8931T has special thermal corner leads, significantly increasing the power capability (reducing  $R_{th}$ ). The corner leads (pins 1, 10, 11 and 20) should be attached to a copper area ( $V_{SS}$ ) on the PCB for cooling.

The typical thermal resistance  $R_{th(j-a)}$  of the TDA8931T is 24 K/W (free air and natural convection) when soldered on a double sided FR4 PCB with 35 μm copper layer and cooling area of approximately of 28 cm<sup>2</sup>.

**14.4.1 Thermal layout including vias**

The bottom side of the double-sided PCB is used to place the SMD components including the TDA8931T and the majority of the signal tracks. The topside is used to place the leaded components.

The remaining area on both top and bottom layer are filled with ground plane for a proper cooling. In this way it is possible to have a cooling area available of about:

- 40 % of the PCB area on the bottom (60 % for signal tracks and SMD components)
- 90 % of the PCB area on the top (10 % for signal tracks)

The PCB area required for a typical mono amplifier is 21.5 cm<sup>2</sup> resulting in a cooling area of about 28 cm<sup>2</sup>. Thermal vias should be placed close to corner leads for a proper heat flow to the top layer of the PCB. [Figure 7](#) is showing the thermal vias indicated as black dots and [Figure 8](#) is showing the heat flow to the copper area on the top layer.

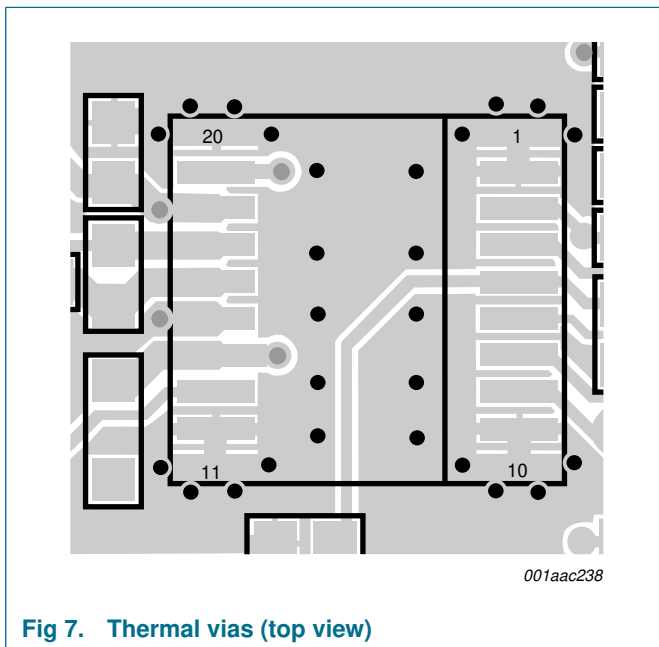

Fig 7. Thermal vias (top view)

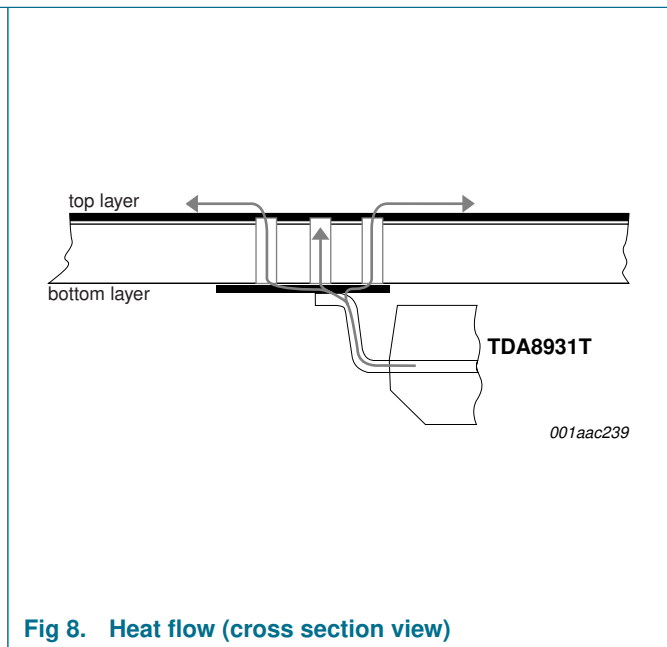

Fig 8. Heat flow (cross section view)

**14.4.2 Thermal considerations**

To estimate the maximum junction temperature, the following equation can be used:

$$T_{j(max)} = T_{amb} + R_{th(j-a)} \times P_d \tag{5}$$

Where:

T<sub>amb</sub> = ambient temperature

P<sub>d</sub> = power dissipation in the TDA8931T

R<sub>th(j-a)</sub> = thermal resistance from junction to ambient (24 K/W)

To estimate the power dissipation, the following equation can be used:

$$P_d = P_o \times \left( \frac{1}{\eta} - 1 \right) \tag{6}$$

Where:

$P_d$  = power dissipation

$P_o$  = RMS output power (W)

$\eta$  = efficiency of total application (0.91 for  $R_L = 8 \Omega$  and 0.89 for  $R_L = 4 \Omega$ )

The derating curves of the dissipated power as a function of ambient temperature for several values of  $R_{th(j-a)}$  are illustrated in [Figure 9](#). A maximum junction temperature  $T_j = 150 \text{ }^\circ\text{C}$  is taken into account.

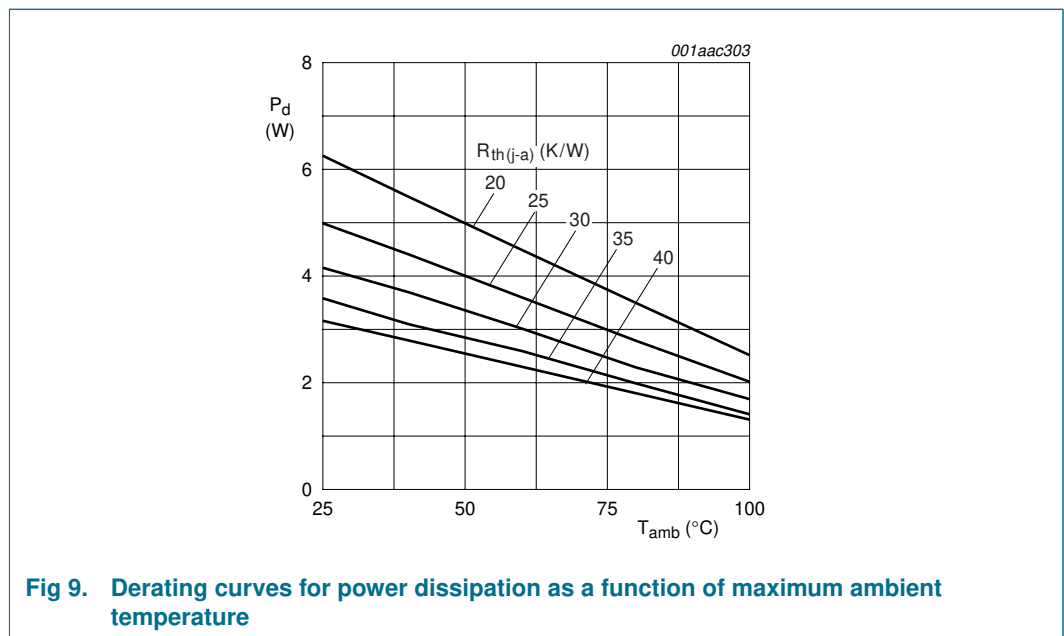

**Fig 9. Derating curves for power dissipation as a function of maximum ambient temperature**

**Example:** TDA8931T mono amplifier, with substituting  $P_o = 1 \times 20 \text{ W}$ ,  $R_{th(j-a)} = 24 \text{ K/W}$ ,  $P_d = 2.47 \text{ W}$  results in a junction temperature  $T_{j(max)} = 119 \text{ }^\circ\text{C}$ .

For this example the estimated maximum junction temperature at a high ambient temperature of  $60 \text{ }^\circ\text{C}$  for a mono amplifier driving  $4 \Omega$  speaker impedance stays below the OTP threshold level of  $150 \text{ }^\circ\text{C}$ .

## 14.5 Measured performance figures of mono amplifier with TDA8931

Table 13: Characteristics

$V_P = 22\text{ V}$ ;  $R_L = 4\ \Omega$ ,  $f_i = 1\text{ kHz}$ ; inverted input signal;  $T_{amb} = 25\text{ }^\circ\text{C}$  unless otherwise specified.

Symbol	Parameter	Conditions	Min	Typ	Max	Unit
$V_P$	operating supply voltage		[1] 12	22	35	V
$P_o$	output power	$V_P = 26\text{ V}$ ; $R_L = 4\ \Omega$				
		THD+N = 10 %	-	22	-	W
		THD+N = 1 %	-	20	-	W
		$V_P = 22\text{ V}$ ; $R_L = 4\ \Omega$				
		THD+N = 10 %	-	16.0	-	W
		THD+N = 1 %	-	12.0	-	W
		$V_P = 30\text{ V}$ ; $R_L = 8\ \Omega$				
		THD+N = 10 %	-	16.0	-	W
THD+N	total harmonic distortion-plus-noise	$P_o = 1\text{ W}$ ; AES17 brick wall filter				
		$V_p = 22\text{ V}$ ; $R_L = 4\ \Omega$	-	0.02	-	%
		$V_p = 30\text{ V}$ ; $R_L = 8\ \Omega$	-	0.02	-	%
$\eta$	efficiency	$P_o = 15\text{ W}$				
		$V_p = 22\text{ V}$ ; $R_L = 4\ \Omega$	-	89	-	%
		$V_p = 30\text{ V}$ ; $R_L = 8\ \Omega$	-	91	-	%
$G_v$	closed loop gain	$V_i = 100\text{ mV (RMS)}$ ; $f_i = 1\text{ kHz}$	-	20	-	dB
$V_{n(o)}$	noise output voltage	inputs shorted; AES17 brick wall filter	-	128	-	$\mu\text{V}$
S/N	signal-to-noise ratio	unwanted; with respect to $V_o = 10\text{ V (RMS)}$	-	98	-	dB
B	band width	-3 dB low; LF cut-off point depends on value of SE capacitances	-	40	-	Hz
		-3 dB high	-	45000	-	Hz
SVRR	supply voltage ripple rejection	$V_p = 22\text{ V}$ ; $R_L = 4\ \Omega$ ; $V_{\text{ripple}} = 2\text{ V (p-p)}$ ; $f_{\text{ripple}} = 100\text{ Hz}$ with feed forward network (470 k $\Omega$ and 15 nF)	45	48	-	dB
$f_c$	idle carrier frequency		-	290	-	kHz

[1] Operates down to UVP threshold level and operates up to OVP threshold level.

14.6 Curves measured in typical application

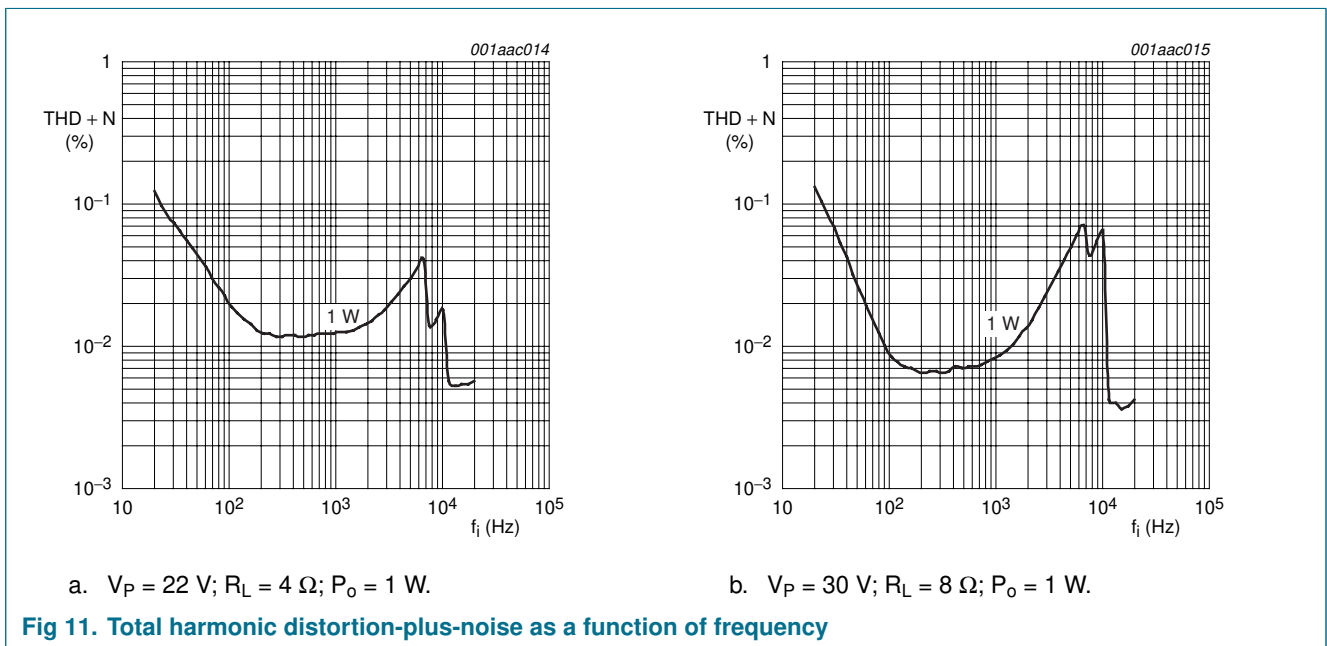
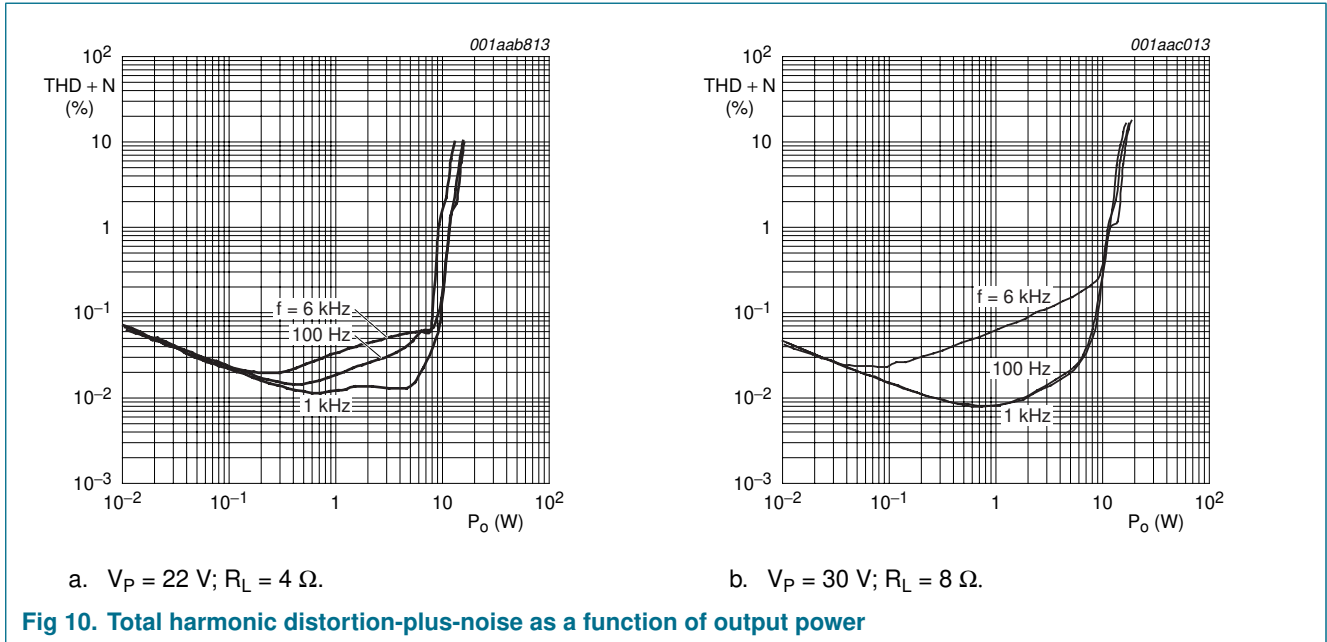

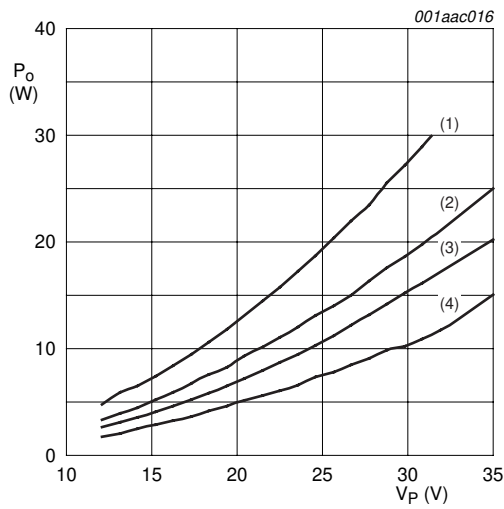

- (1)  $R_L = 4 \Omega$ ; THD = 10 %.
  - (2)  $R_L = 4 \Omega$ ; THD = 0.5 %.
  - (3)  $R_L = 8 \Omega$ ; THD = 10 %.
  - (4)  $R_L = 8 \Omega$ ; THD = 0.5 %.
- Conditions:  $f_i = 1 \text{ kHz}$ .

Fig 12. Output power as a function of supply voltage

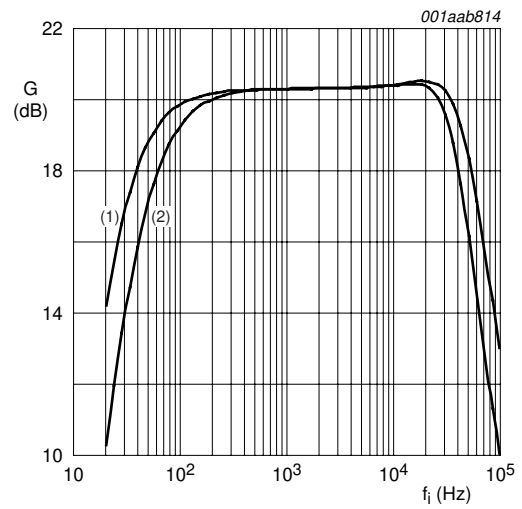

- (1)  $R_L = 8 \Omega$ .
  - (2)  $R_L = 4 \Omega$ .
- Conditions:  $V_p = 22 \text{ V}$ ;  $V_i = 100 \text{ mV}$ .

Fig 13. Gain as a function of frequency

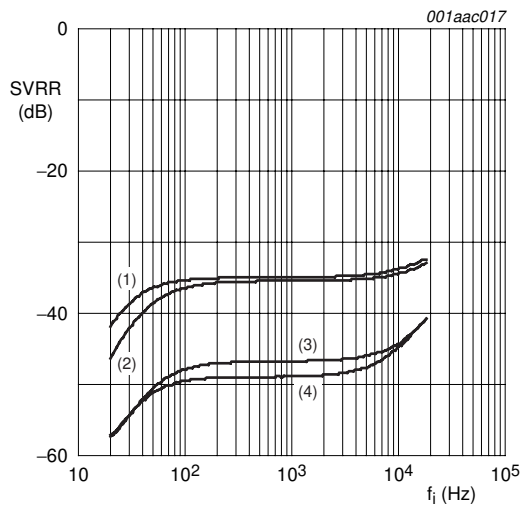

- (1)  $R_L = 8 \Omega$ .
  - (2)  $R_L = 4 \Omega$ .
  - (3)  $R_L = 4 \Omega$  with feed forward network  $470 \text{ k}\Omega / 15 \text{ nF}$ .
  - (4)  $R_L = 8 \Omega$  with feed forward network  $470 \text{ k}\Omega / 15 \text{ nF}$ .
- Conditions:  $V_{\text{ripple}} = 2 \text{ V}$  (p-p).

Fig 14. SVRR as a function of frequency

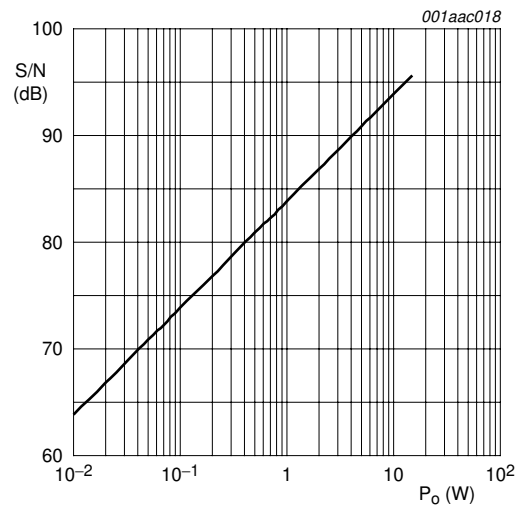

- Conditions:  $V_p = 22 \text{ V}$ ;  $R_L = 4 \Omega$ ; including AES 20 kHz filter.

Fig 15. Signal-to-noise ratio as a function of output power



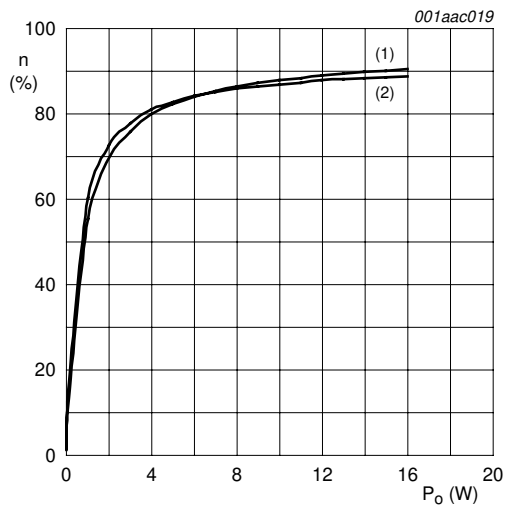

(1)  $V_P = 30\text{ V}; R_L = 8\ \Omega$ .  
 (2)  $V_P = 22\text{ V}; R_L = 4\ \Omega$ .  
 Conditions:  $f_i = 1\text{ kHz}$ .

Fig 16. Efficiency as a function of total output power

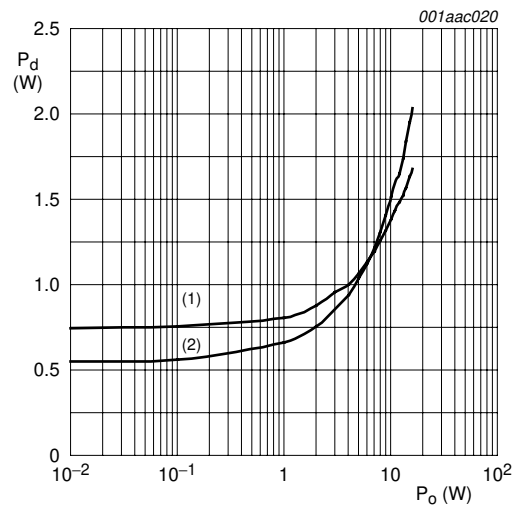

(1)  $V_P = 30\text{ V}; R_L = 8\ \Omega$ .  
 (2)  $V_P = 22\text{ V}; R_L = 4\ \Omega$ .  
 Conditions:  $f_i = 1\text{ kHz}$ .

Fig 17. Power dissipation as a function of total output power

## 15. Test information

**Remark:** Only valid if the TDA8931 is used as an audio amplifier.

### 15.1 Quality information

The *General Quality Specification for Integrated Circuits, SNW-FQ-611* is applicable.

16. Package outline

SO20: plastic small outline package; 20 leads; body width 7.5 mm

SOT163-1

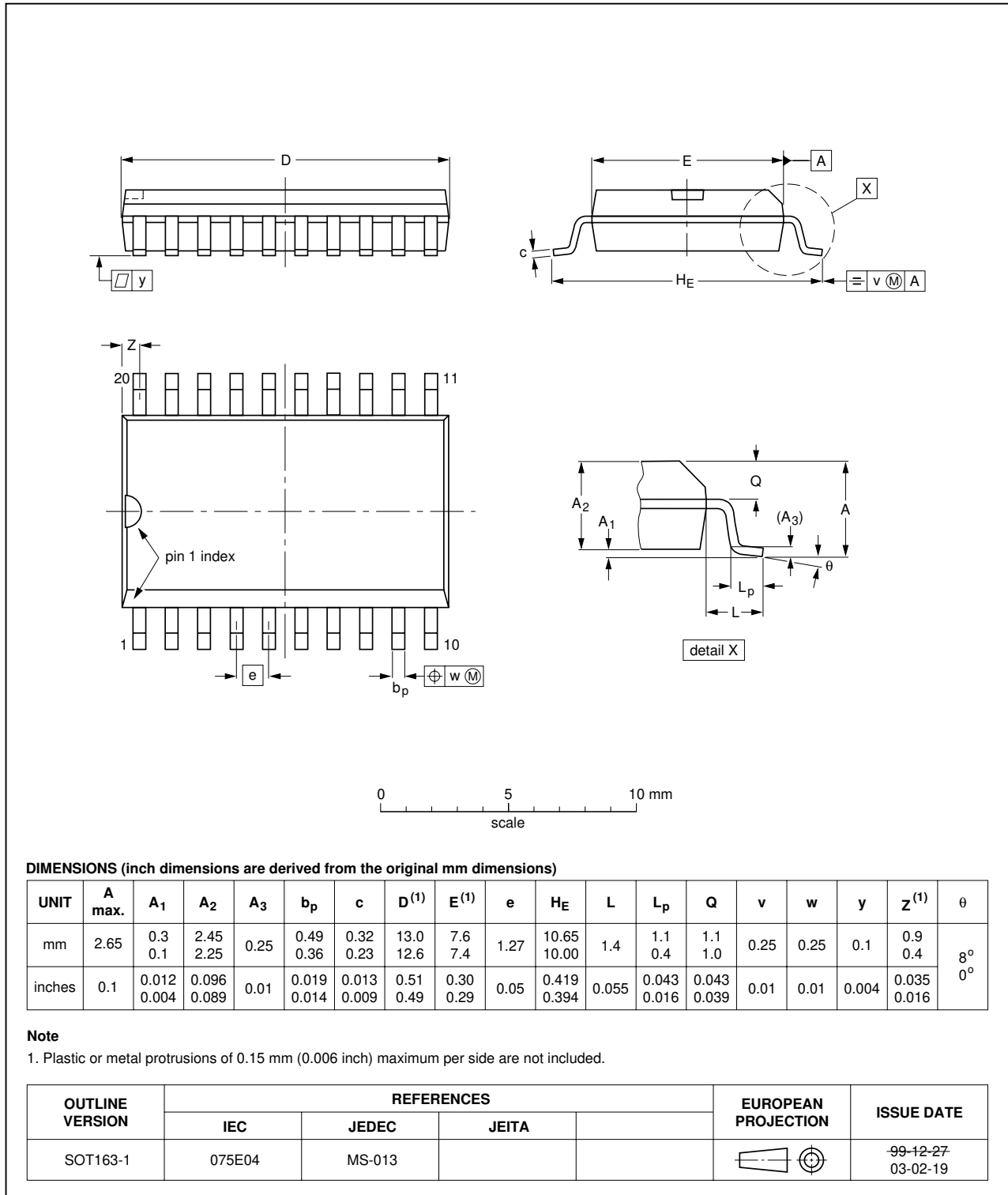

Fig 18. Package outline SOT163-1 (SO20)