



Chipsmall Limited consists of a professional team with an average of over 10 year of expertise in the distribution of electronic components. Based in Hongkong, we have already established firm and mutual-benefit business relationships with customers from,Europe,America and south Asia,supplying obsolete and hard-to-find components to meet their specific needs.

With the principle of "Quality Parts,Customers Priority,Honest Operation,and Considerate Service",our business mainly focus on the distribution of electronic components. Line cards we deal with include Microchip,ALPS,ROHM,Xilinx,Pulse,ON,Everlight and Freescale. Main products comprise IC,Modules,Potentiometer,IC Socket,Relay,Connector.Our parts cover such applications as commercial,industrial, and automotives areas.

We are looking forward to setting up business relationship with you and hope to provide you with the best service and solution. Let us make a better world for our industry!



Contact us

Tel: +86-755-8981 8866 Fax: +86-755-8427 6832

Email & Skype: info@chipsmall.com Web: www.chipsmall.com

Address: A1208, Overseas Decoration Building, #122 Zhenhua RD., Futian, Shenzhen, China



DATA SHEET

TDA9830

TV sound AM-demodulator and
audio source switch

Product specification
File under Integrated Circuits, IC02

June 1994

TV sound AM-demodulator and audio source switch

TDA9830

FEATURES

- Adjustment free wideband synchronous AM demodulator
- Audio source-mute switch (low noise)
- Audio level according EN50049
- 5 to 8 V power supply or 12 V alternative
- Low power consumption.

GENERAL DESCRIPTION

The TDA9830, a monolithic integrated circuit, is designed for AM-sound demodulation used in L- and L'-standard. The IC provides an audio source selector and also mute switch.

QUICK REFERENCE DATA

SYMBOL	PARAMETER	MIN.	TYP.	MAX.	UNIT
V ₁₄	positive supply voltage	4.5	5.0	8.8	V
V ₁₁	supply voltage (alternative)	10.8	12.0	13.2	V
I _{14,11}	supply current	24	30	36	mA
V ₁₋₁₆	IF sensitivity (RMS value) (for -3 dB AF-signal)	-	60	100	μV
G _v	gain control	60	66	-	dB
V ₆	AF output signal (m = 54%) (RMS value)	400	500	600	mV
V ₆	S/N ratio acc. CCIR468-3 (IF-signal 10 mV _{RMS})	47	53	-	dB
V _{7,9}	AF input signal (for THD < 1.5%) (RMS value)	-	-	1.2	V
V ₈	crosstalk and mute attenuation	80	90	-	dB
T _{amb}	operating ambient temperature	0	-	+70	°C

ORDERING INFORMATION

EXTENDED TYPE NUMBER	PACKAGE			
	PINS	PIN POSITION	MATERIAL	CODE
TDA9830	16	DIL	plastic	SOT38GG ⁽¹⁾
TDA9830T	16	SO	plastic	SOT109 ⁽²⁾

Note

1. SOT38-1; 1996 November 20.
2. SOT109-1; 1996 November 20.

TV sound AM-demodulator and audio source switch

TDA9830

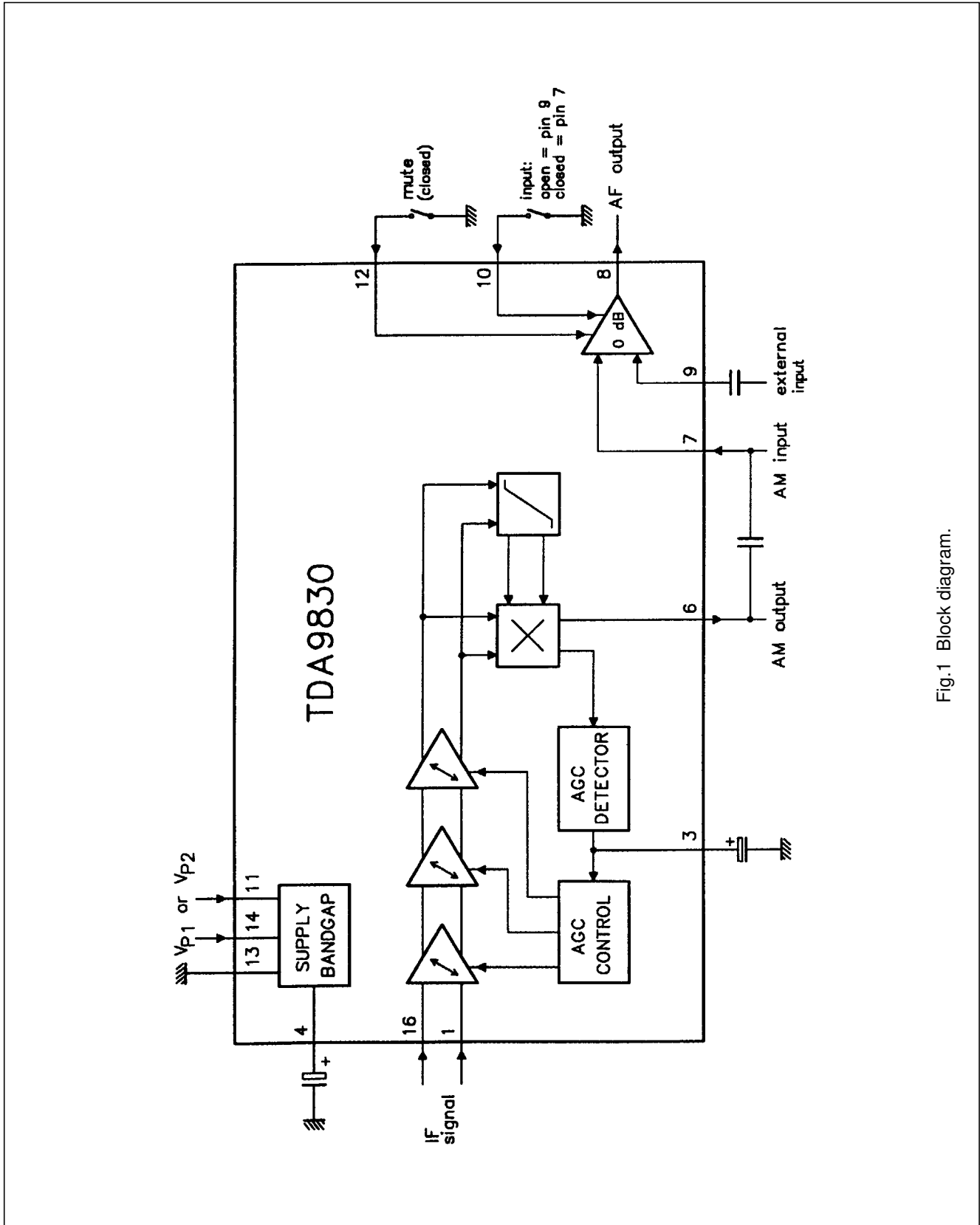

Fig.1 Block diagram.

TV sound AM-demodulator and audio source switch

TDA9830

PINNING

SYMBOL	PIN	DESCRIPTION
IFIN	1	sound IF differential input signal
n.c.	2	not connected
C _{AGC}	3	AGC capacitor
C _{REF}	4	REF voltage filtering capacitor
n.c.	5	not connected
AMOUT	6	AM demodulator output
AMIN	7	input signal (from AM) to audio switch
AFOUT	8	output signal from audio switch
EXTIN	9	input signal (from external) to audio switch
SWITCH	10	switch input select control
V _{p2}	11	supply voltage +12 V (alternative)
MUTE	12	mute control
GND	13	ground (0 V)
V _{p1}	14	supply voltage +5 to +8 V
n.c.	15	not connected
IFIN	16	sound IF differential input signal

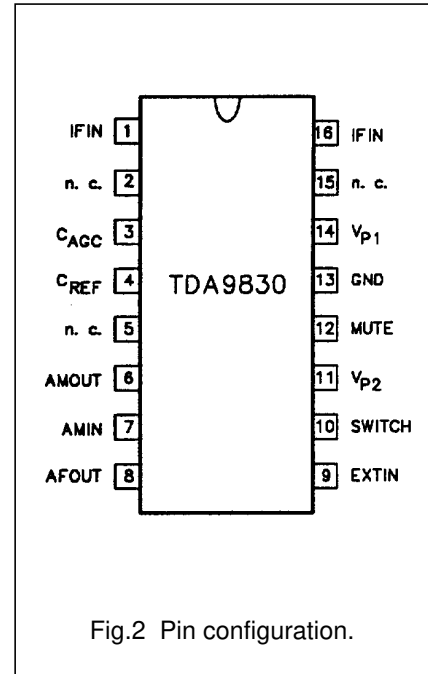

Fig.2 Pin configuration.

FUNCTIONAL DESCRIPTION

Sound IF input

The sound IF amplifier consists of three AC-coupled differential amplifier stages each with approximately 20 dB gain. At the output of each stage is a multiplier for gain controlling (\rightarrow current distribution gain control). The overall control range is approximately -6 to $+60$ dB and the frequency response (-3 dB) of the IF amplifier is approximately 6 to 70 MHz. The steepness of gain control is approximately 10 mV/dB.

IF AGC

The automatic gain control voltage to maintain the AM demodulator output signal at a constant level is generated by a mean level detector. This AGC-detector charges and discharges the capacitor at pin 3 controlled by the output signal of the AM-demodulator compared to an internal reference voltage. The

maximum charge/discharge current is approximately 5 μ A. This value in combination with the value of the AGC capacitor and the AGC steepness determines the lower cut-off audio frequency and the THD-figure at low modulation frequency of the whole AM-demodulator. Therefore a large time constant has to be chosen which leads to slow AGC reaction at IF level change. To speed up the AGC in case of IF signal jump from low to high level, there is an additional comparator built in, which can provide additional discharge current from the AGC capacitor up to 5 mA in a case of overloading the AM demodulator by the internal IF signal.

AM-demodulator

The IF amplifier output signal is fed to a limiting amplifier (two stages) and to a multiplier circuit. However the limiter output signal (which is not any more AM modulated) is also fed to the multiplier, which provides AM

demodulation (in phase demodulation). After lowpass filtering ($f_g \approx 400$ kHz) for carrier rejection and buffering, the demodulator output signal is present at pin 6. The AM demodulator operates over a wide frequency range, so that in combination with the frequency response of the IF amplifier applications in a frequency range from approximately 6 MHz up to 70 MHz are possible.

Audio switch

This circuit is an operational amplifier with three input stages and internal feedback network determining gain (0 dB) and frequency response ($f_g \approx 700$ kHz). Two of the input stages are connected to pin 7 and pin 9, the third input stage to an internal reference voltage. Controlled by the switching pins 10 and 12, one of the three input stages can be activated and a choice made between two different AF signals or mute state. The selected signal is present at

TV sound AM-demodulator and audio source switch

TDA9830

pin 8. The decoupling capacitors at the input pins are needed, because the internally generated bias voltage for the input stages must not be influenced by the application in order to avoid DC-plop in case of switching.

The AM demodulator output is designed to provide almost the same DC voltage as the input bias voltage of the audio switch. But there may be spread between both voltages.

Therefore it is possible to connect pin 6 directly to pin 7 (without a decoupling capacitor), but in this event the DC-plop for switching can increase up to 100 mV.

Reference circuit

This circuit is a band gap stabilizer in combination with a voltage regulation amplifier, which provides an internal reference voltage of about 3.6 V nearly independent from supply voltage and temperature. This reference voltage is filtered by the capacitor at pin 4 in order to reduce noise. It is used as a reference to generate all important voltages and currents of the circuit.

For application in 12 V power supply concepts, there is an internal voltage divider in combination with a

Darlington transistor in order to reduce the supply voltage for all IC function blocks to approximately 6 V. This is necessary because of use of modern high frequency IC technology, where most of the used integrated components are only allowed to operate at maximum 9 V supply voltage.

LIMITING VALUES

In accordance with the Absolute Maximum Rating System (IEC134).

SYMBOL	PARAMETER	MIN.	MAX.	UNIT
V_{14-13}	supply voltage V_{P1}	-0.5	+8.9	V
V_{11-13}	supply voltage V_{P2}	-0.5	+13.3	V
$V_{10, 12-13}$	switching voltage	-0.5	$V_P + 0.5$	V
T_{amb}	operating ambient temperature	0	+70	°C
T_{stg}	storage temperature	-25	+150	°C

Note to the limiting values

- To avoid an inadmissible increase of ambient temperature, it is not allowed to short-circuit pin 11 for more than 10 seconds to ground.

THERMAL RESISTANCE

SYMBOL	PARAMETER	THERMAL RESISTANCE
$R_{th j-a}$	from junction to ambient in free air SOT38 SOT109	74 K/W 100 K/W

TV sound AM-demodulator and audio source switch

TDA9830

CHARACTERISTICS

$V_{P1} = 5.0$ V at pin 14; $T_{amb} = +25$ °C; sound carrier $f_{SC} = 32.4$ MHz modulated with $f = 1$ kHz and modulation depth $m = 54\%$. IF input signal (sound carrier): V_{1-16} 10 mV_{RMS}; unless otherwise specified.

SYMBOL	PARAMETER	CONDITIONS	MIN.	TYP.	MAX.	UNIT
V_{14-13}	positive supply voltage V_{P1}	note 1	4.5	5.0	8.8	V
V_{11-13}	positive supply voltage V_{P2}	note 1	10.8	12.0	13.2	V
I_{11}/I_{14}	current consumption		24	30	36	mA
IF amplifier and gain control						
R_{1-16}	input resistance		1.75	2.2	2.65	k Ω
C_{1-16}	input capacitance		1.0	1.5	2.2	pF
V_{1-16}	minimum IF input signal (RMS value)	note 2	–	60	100	μ V
V_{1-16}	maximum IF input signal (RMS value)	note 3	70	120	–	mV
G_v	gain control		60	66	–	dB
I_3	maximum AGC charging/discharging current		3.5	5	7	μ A
I_3	fast AGC discharging current		–	–	5	mA
$V_3 - V_{13}$	gain control voltage ($G_{min} - G_{max}$)		1.5	–	2.8	V
B	–3 dB IF bandwidth	upper cut-off frequency	50	70	–	MHz
		lower cut-off frequency	–	6	10	MHz
$V_{1/16-13}$	DC potential		–	1.7	–	V
AM-Demodulator						
V_{6-13}	AF output signal (RMS value)		400	500	600	mV
B	–3 dB AF bandwidth	upper cut-off frequency	100	–	–	kHz
		lower cut-off frequency; note 7	–	–	20	Hz
V_{6-13}	THD		–	0.8	2	%
V_{6-13}	S/N (weighted acc. CCIR 468-3)		47	53	–	dB
V_{6-13}	DC potential		2.00	2.15	2.30	V
R_6	output resistance (emitter follower with 0.5 mA bias current)		–	300	–	Ω
I_{6abs}	allowable AC output current		–	–	0.3	mA
I_6	allowable DC output current		–	–	–0.5	mA
Audio-switch						
$V_{7,9-13}$	AF-input-signal for THD < 1.5% (RMS value)		–	–	1.2	V
V_{8-13}	S/N ratio of audio switch (in accordance with CCIR 468-3)	reference signal at pin 7/9 is 0.5 V _{RMS}	70	80	–	dB
B	–3 dB AF bandwidth	upper limit	100	–	–	kHz
V_{8-13}	THD at 1 V _{RMS} input signal at pin 7 or 9		–	0.1	1.0	%

TV sound AM-demodulator and audio source switch

TDA9830

SYMBOL	PARAMETER	CONDITIONS	MIN.	TYP.	MAX.	UNIT
V_{8-13}	crosstalk and mute attenuation	20 Hz to 20 kHz	80	90	–	dB
$V_{7,8,9-13}$	DC-potential		2.00	2.15	2.30	V
$R_{7,9-13}$	input resistance		40	50	60	k Ω
$G_{7,9-8}$	gain of audio switch		–0.5	0	+0.5	dB
V_{10-13}	audio switching voltage to activate pin 7		0	–	0.8	V
V_{10-13}	audio switching voltage to activate pin 9	note 4	1.5	–	V_P	V
V_{12-13}	input voltage for MUTE-ON		0	–	0.8	V
	input voltage for MUTE-OFF	note 4	1.5	–	V_P	V
$I_{10, 12}$	output current of switching-pins at $V_{10, 12-13} = 0$ V		–110	–145	–185	μ A
V_{8-13}	DC-plop at AF output pin with switching from internal to external audio signal or to mute-state or vice-versa	note 5	–	5	10	mV
R_8	output resistance		70	100	150	Ω
Ripple rejection note 6						
RR	AF signal output: $\alpha_{RR} = V_{\text{ripple on } V_P} / V_{\text{ripple on } V_{\text{out}}}$		26	30	–	dB
	AF signal output with AF signal from external source		40	44	–	dB

Notes to the characteristics

- In the power supply voltage range $V_{P1} = 5.0$ V up to 8.0 V the performance will not change essentially. With power supply from $V_{P2} = 12.0$ V the performance will be comparable with the performance at $V_{P1} = 5.0$ V up to 8.0 V. The unused power supply pin must be not connected.
- Start of gain control (low IF input signal) at –3 dB AF signal reduction at pin 6.
- End of gain control (high IF input signal) at +1 dB AF signal expansion at pin 6.
- This state is also valid for pin left open-circuit.
- If a DC-plop of about maximum 100 mV is acceptable when switching from internal to external audio-signal or from internal to mute state or vice versa, the capacitor between pin 6 and 7 can be omitted and pin 6 can be connected to pin 7.
- Measured with $V_{\text{ripple}} = 200$ mV_(p-p) at 70 Hz superimposed on supply voltage V_P .
- Dependent on value of AGC capacitor.

TV sound AM-demodulator and audio source switch

TDA9830

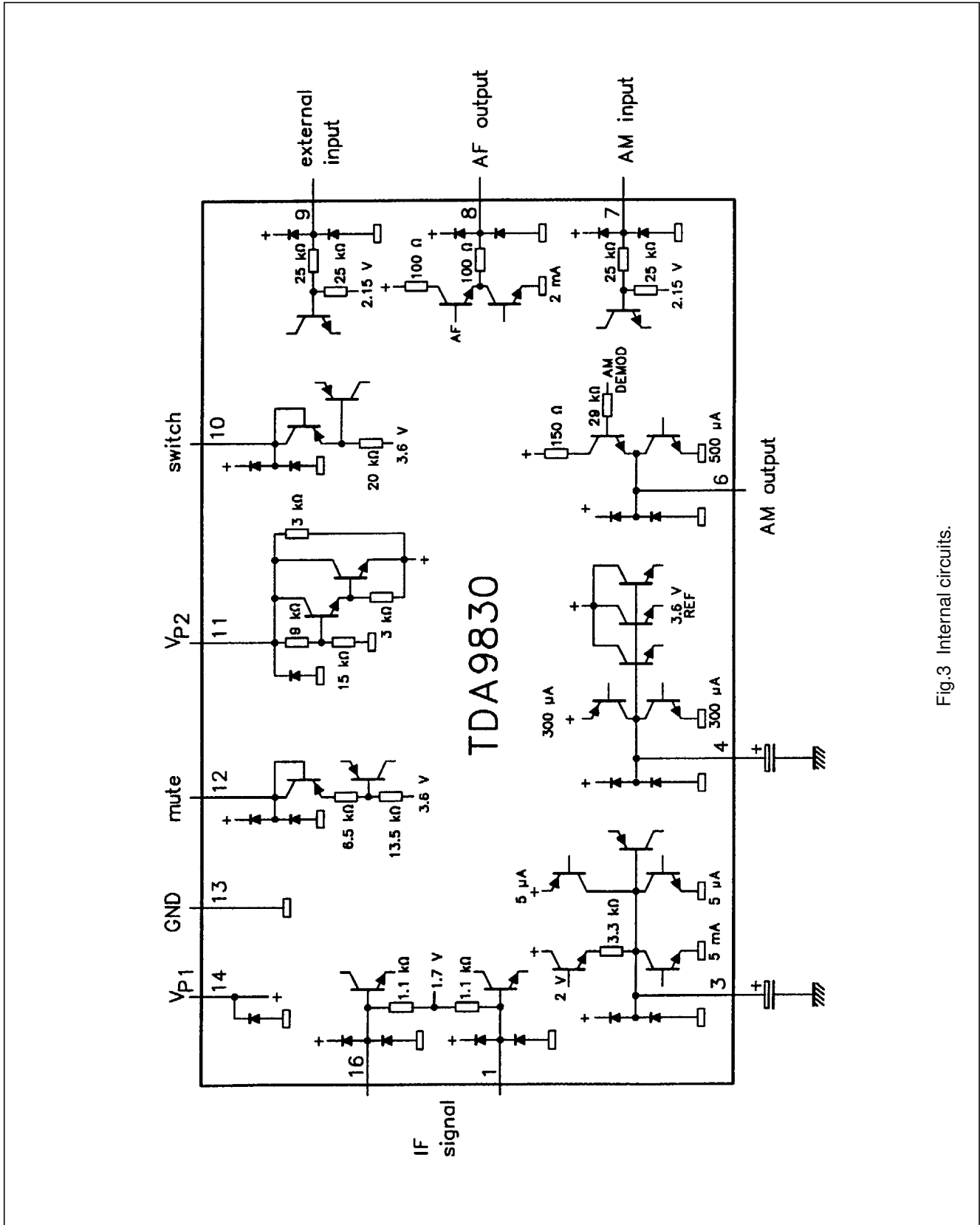
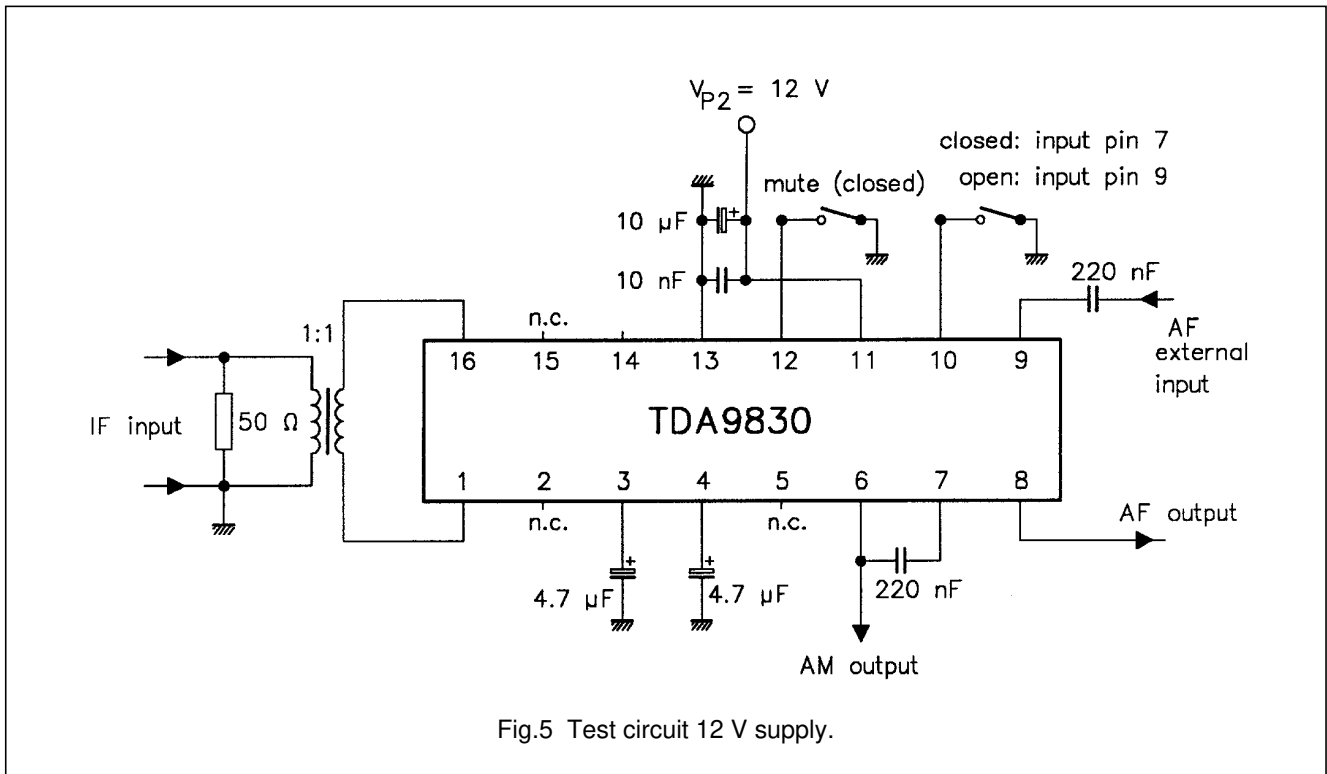
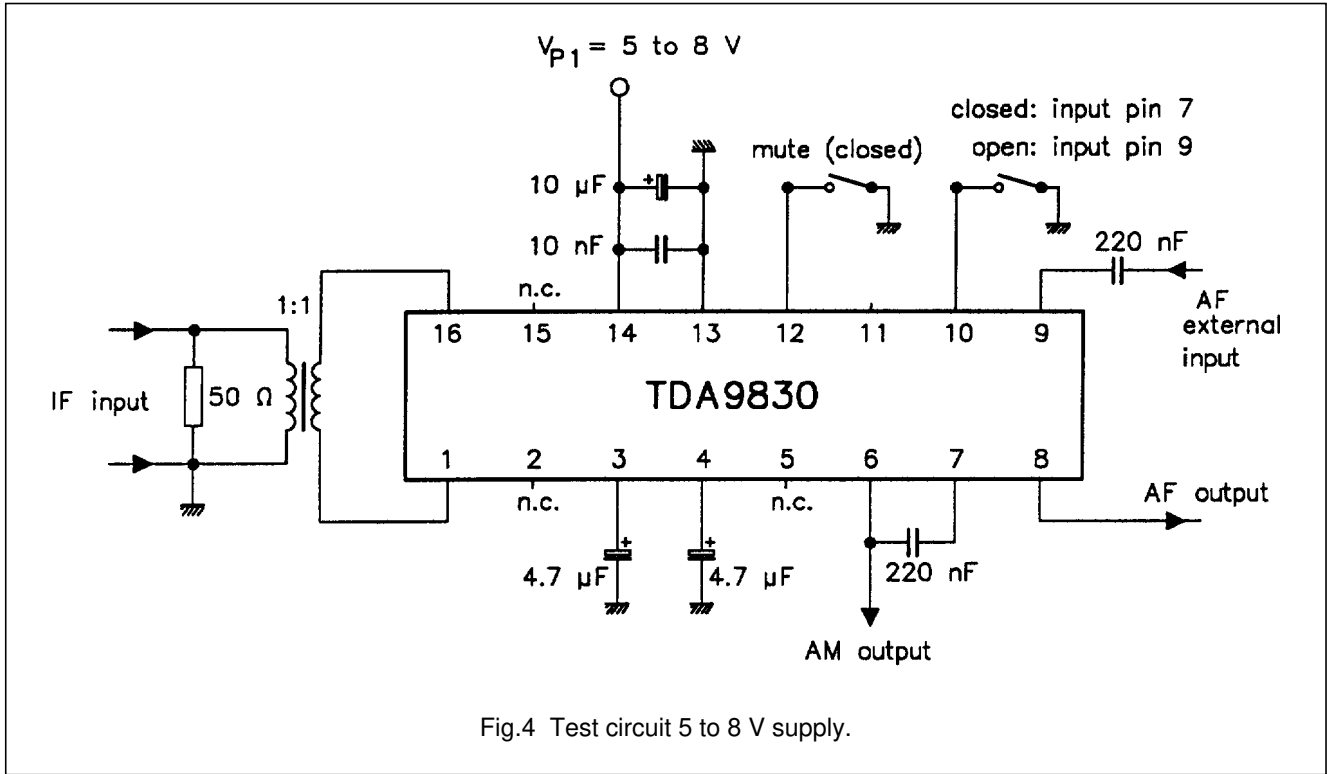

Fig.3 Internal circuits.

TV sound AM-demodulator and audio source switch

TDA9830



TV sound AM-demodulator and audio source switch

TDA9830

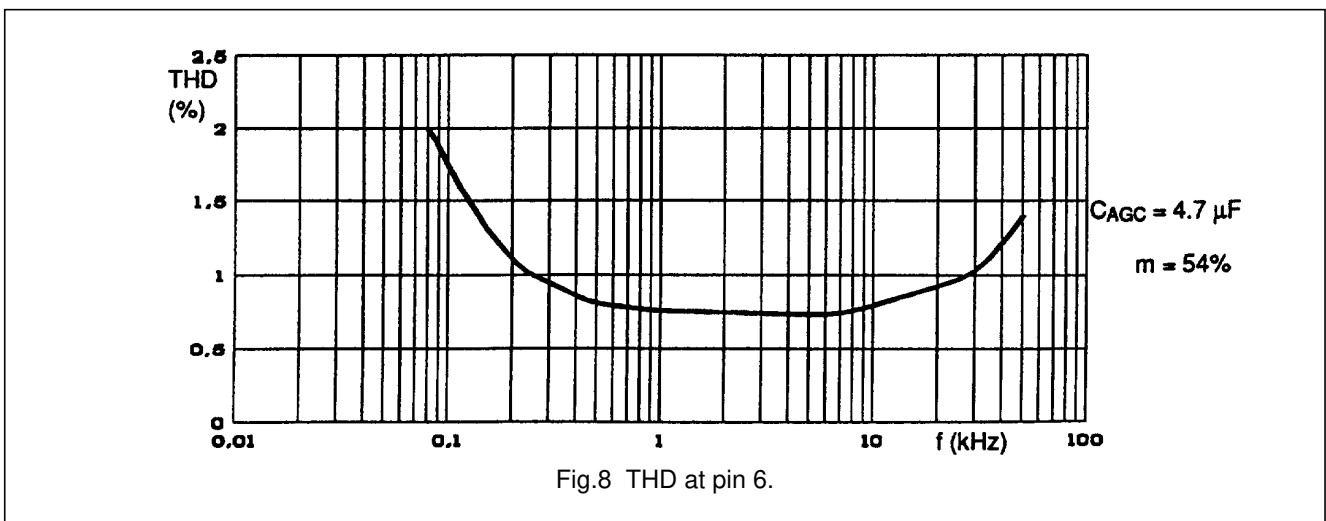
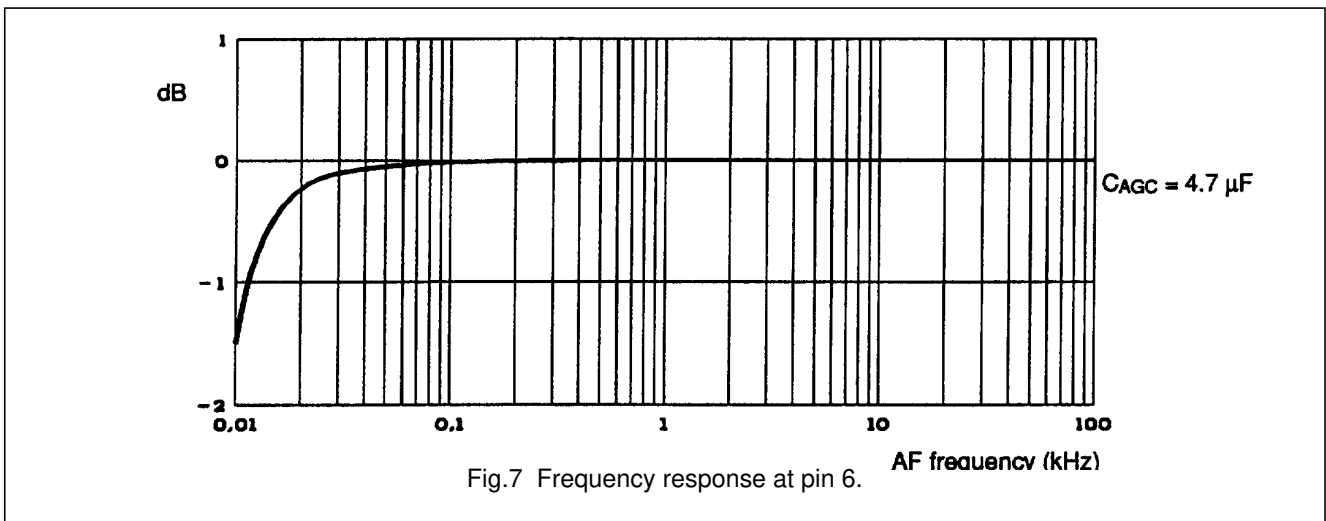
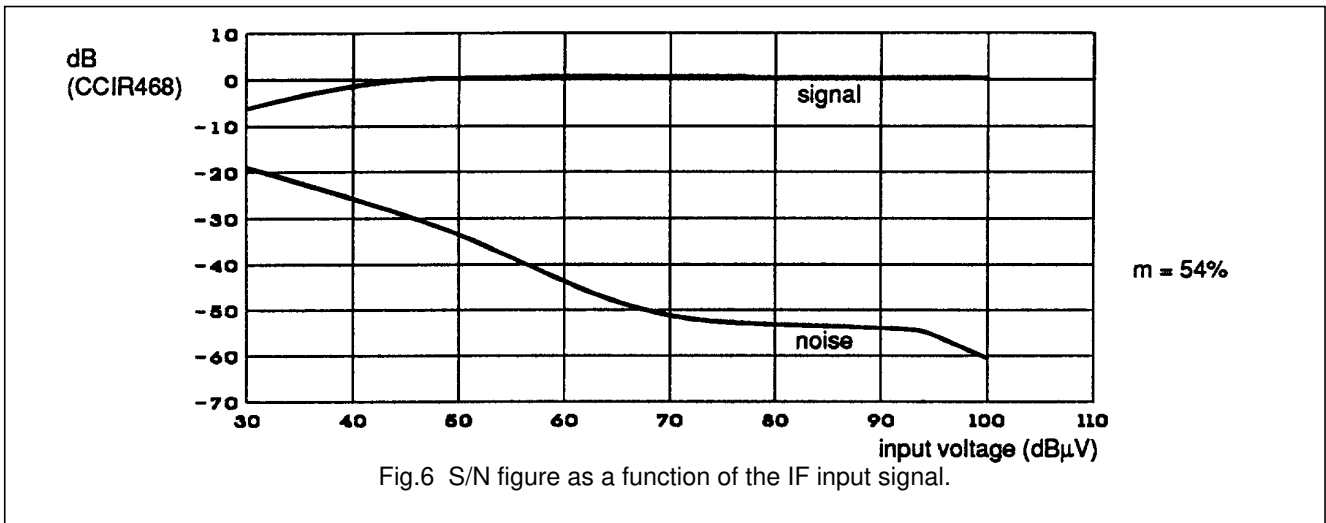

TV sound AM-demodulator and audio source switch

TDA9830

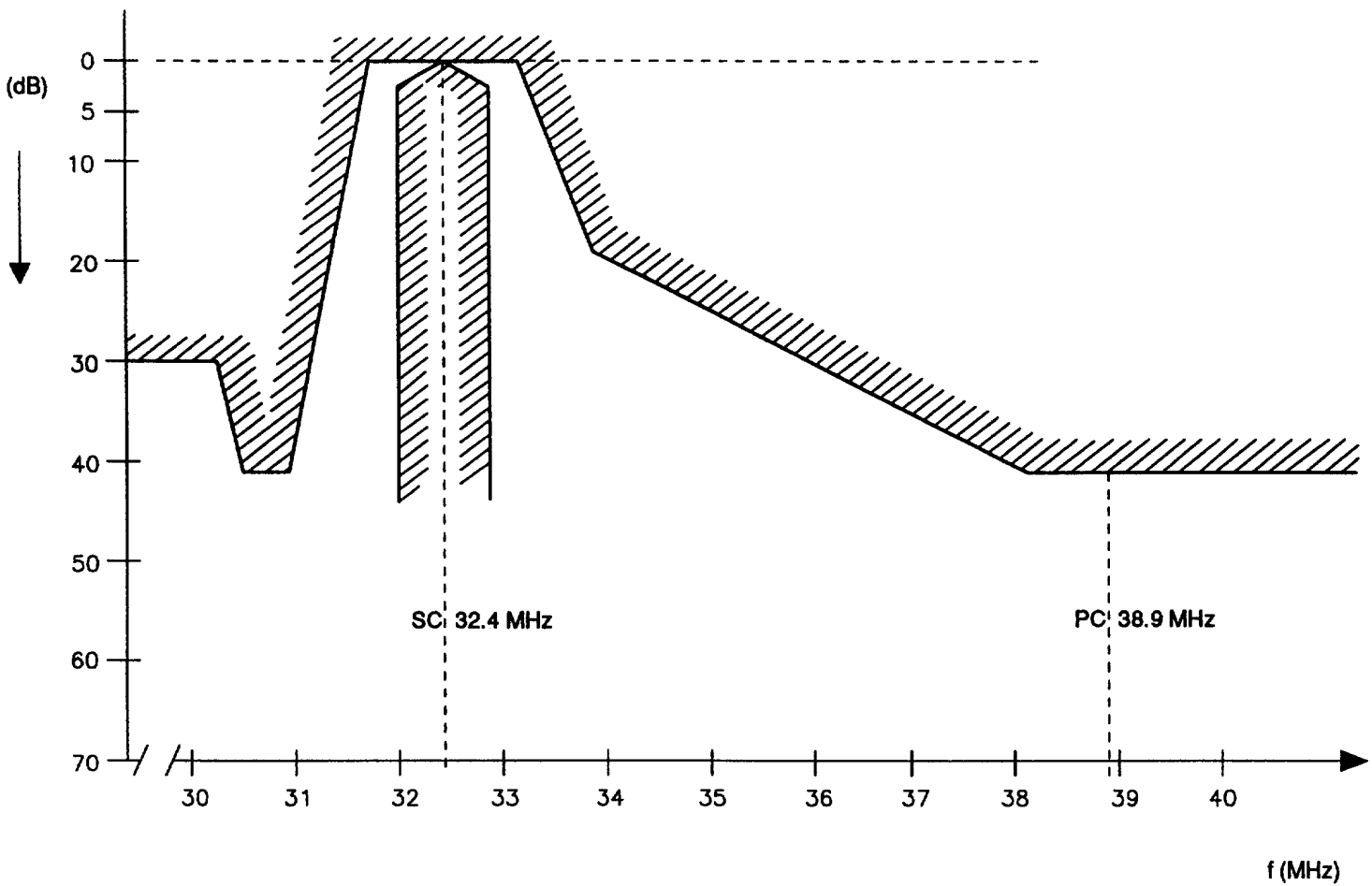

Fig.9 Proposed tolerance scheme IF filter for standard L.

With an IF filter according to this proposal, the video buzz suppression on the audio output is better than 50 dB (in accordance with CCIR468-3, $m = 54\%$) for the worst case video modulation with 6 kHz sinewave black-to-white.

TV sound AM-demodulator and audio source switch

TDA9830

PACKAGE OUTLINES

DIP16: plastic dual in-line package; 16 leads (300 mil); long body

SOT38-1

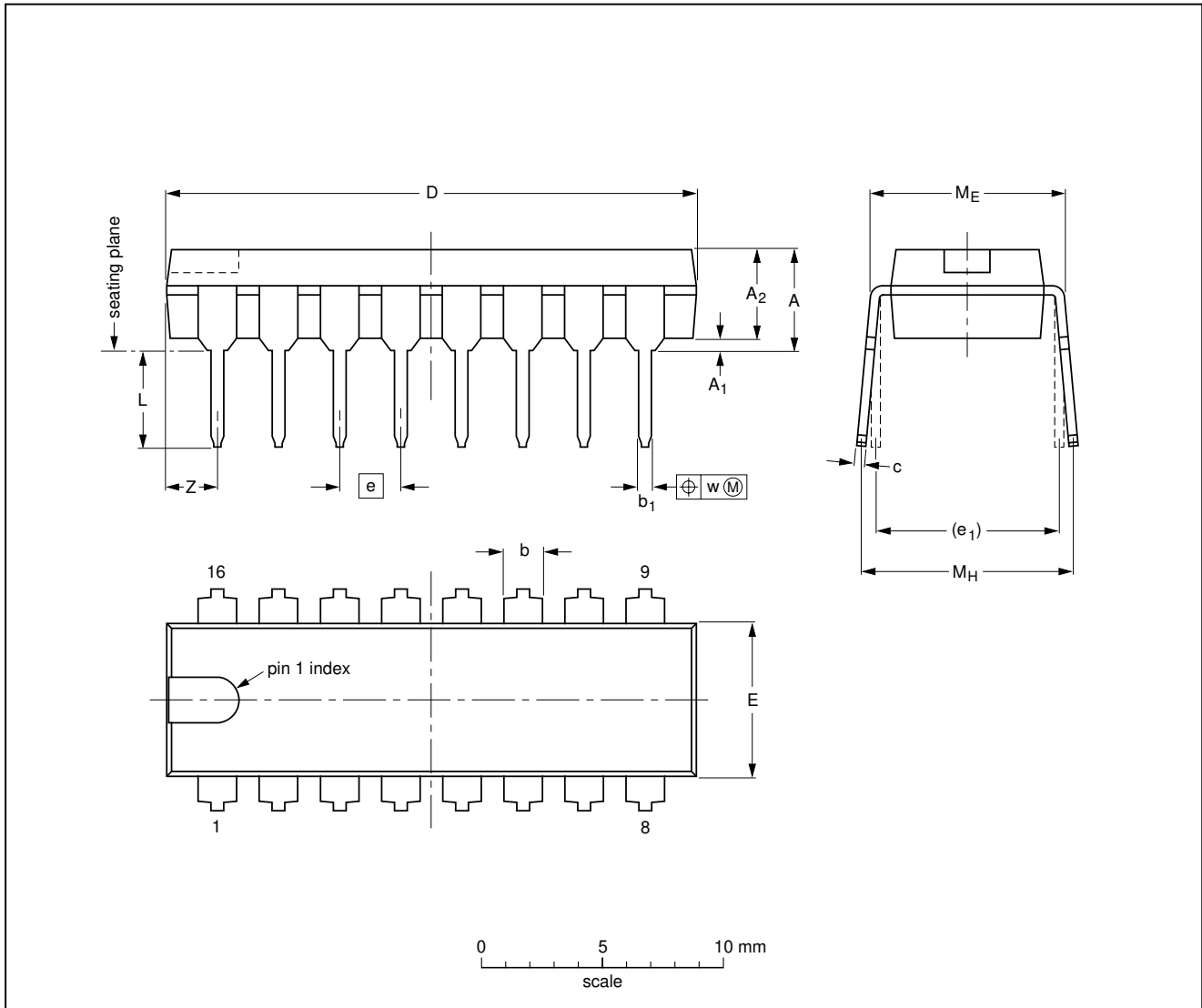

DIMENSIONS (inch dimensions are derived from the original mm dimensions)

UNIT	A max.	A ₁ min.	A ₂ max.	b	b ₁	c	D ⁽¹⁾	E ⁽¹⁾	e	e ₁	L	M _E	M _H	w	Z ⁽¹⁾ max.
mm	4.7	0.51	3.7	1.40 1.14	0.53 0.38	0.32 0.23	21.8 21.4	6.48 6.20	2.54	7.62	3.9 3.4	8.25 7.80	9.5 8.3	0.254	2.2
inches	0.19	0.020	0.15	0.055 0.045	0.021 0.015	0.013 0.009	0.86 0.84	0.26 0.24	0.10	0.30	0.15 0.13	0.32 0.31	0.37 0.33	0.01	0.087

Note

1. Plastic or metal protrusions of 0.25 mm maximum per side are not included.

OUTLINE VERSION	REFERENCES				EUROPEAN PROJECTION	ISSUE DATE
	IEC	JEDEC	EIAJ			
SOT38-1	050G09	MO-001AE				92-10-02 95-01-19

TV sound AM-demodulator and audio source switch

TDA9830

SO16: plastic small outline package; 16 leads; body width 3.9 mm

SOT109-1

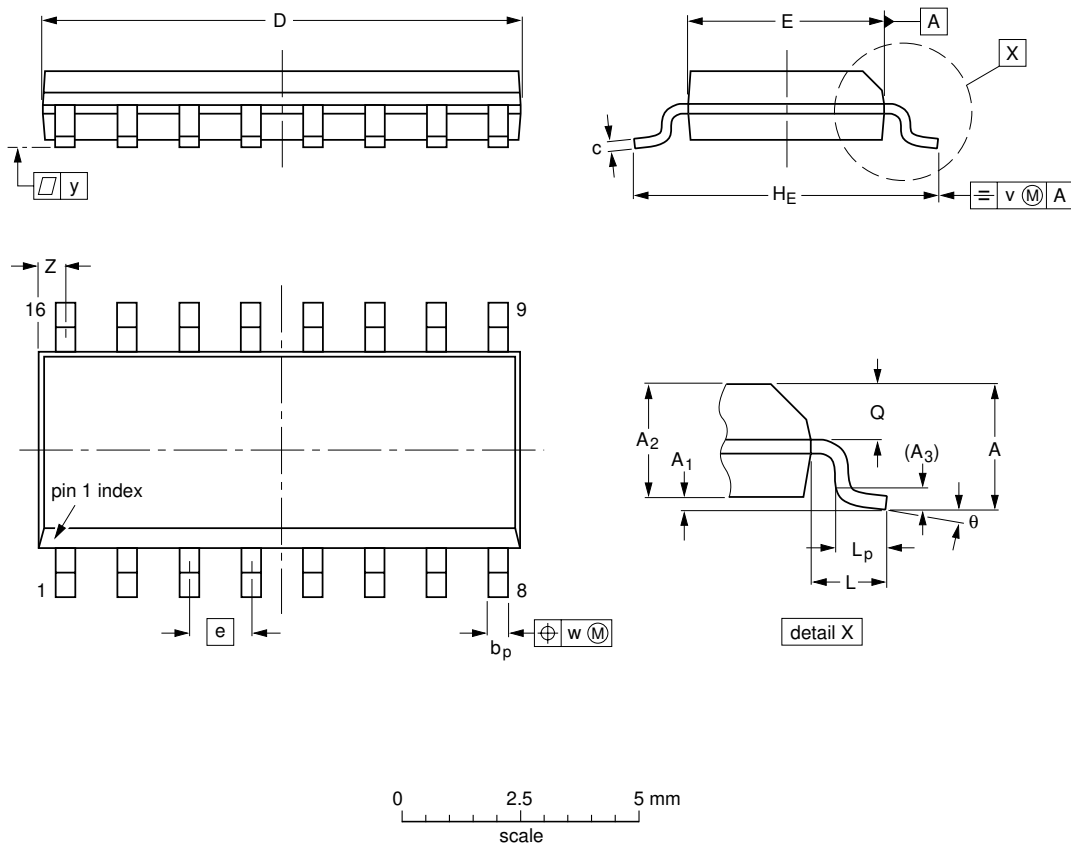

DIMENSIONS (inch dimensions are derived from the original mm dimensions)

UNIT	A max.	A ₁	A ₂	A ₃	b _p	c	D ⁽¹⁾	E ⁽¹⁾	e	H _E	L	L _p	Q	v	w	y	Z ⁽¹⁾	θ
mm	1.75	0.25 0.10	1.45 1.25	0.25	0.49 0.36	0.25 0.19	10.0 9.8	4.0 3.8	1.27	6.2 5.8	1.05	1.0 0.4	0.7 0.6	0.25	0.25	0.1	0.7 0.3	8° 0°
inches	0.069	0.010 0.004	0.057 0.049	0.01	0.019 0.014	0.0100 0.0075	0.39 0.38	0.16 0.15	0.050	0.244 0.228	0.041	0.039 0.016	0.028 0.020	0.01	0.01	0.004	0.028 0.012	

Note

1. Plastic or metal protrusions of 0.15 mm maximum per side are not included.

OUTLINE VERSION	REFERENCES				EUROPEAN PROJECTION	ISSUE DATE
	IEC	JEDEC	EIAJ			
SOT109-1	076E07S	MS-012AC				95-01-23 97-05-22

TV sound AM-demodulator and audio source switch

TDA9830

SOLDERING**Introduction**

There is no soldering method that is ideal for all IC packages. Wave soldering is often preferred when through-hole and surface mounted components are mixed on one printed-circuit board. However, wave soldering is not always suitable for surface mounted ICs, or for printed-circuits with high population densities. In these situations reflow soldering is often used.

This text gives a very brief insight to a complex technology. A more in-depth account of soldering ICs can be found in our *"IC Package Databook"* (order code 9398 652 90011).

DIP**SOLDERING BY DIPPING OR BY WAVE**

The maximum permissible temperature of the solder is 260 °C; solder at this temperature must not be in contact with the joint for more than 5 seconds. The total contact time of successive solder waves must not exceed 5 seconds.

The device may be mounted up to the seating plane, but the temperature of the plastic body must not exceed the specified maximum storage temperature ($T_{stg\ max}$). If the printed-circuit board has been pre-heated, forced cooling may be necessary immediately after soldering to keep the temperature within the permissible limit.

REPAIRING SOLDERED JOINTS

Apply a low voltage soldering iron (less than 24 V) to the lead(s) of the package, below the seating plane or not more than 2 mm above it. If the temperature of the soldering iron bit is less than 300 °C it may remain in contact for up to 10 seconds. If the bit temperature is between 300 and 400 °C, contact may be up to 5 seconds.

SO**REFLOW SOLDERING**

Reflow soldering techniques are suitable for all SO packages.

Reflow soldering requires solder paste (a suspension of fine solder particles, flux and binding agent) to be applied

to the printed-circuit board by screen printing, stencilling or pressure-syringe dispensing before package placement.

Several techniques exist for reflowing; for example, thermal conduction by heated belt. Dwell times vary between 50 and 300 seconds depending on heating method. Typical reflow temperatures range from 215 to 250 °C.

Preheating is necessary to dry the paste and evaporate the binding agent. Preheating duration: 45 minutes at 45 °C.

WAVE SOLDERING

Wave soldering techniques can be used for all SO packages if the following conditions are observed:

- A double-wave (a turbulent wave with high upward pressure followed by a smooth laminar wave) soldering technique should be used.
- The longitudinal axis of the package footprint must be parallel to the solder flow.
- The package footprint must incorporate solder thieves at the downstream end.

During placement and before soldering, the package must be fixed with a droplet of adhesive. The adhesive can be applied by screen printing, pin transfer or syringe dispensing. The package can be soldered after the adhesive is cured.

Maximum permissible solder temperature is 260 °C, and maximum duration of package immersion in solder is 10 seconds, if cooled to less than 150 °C within 6 seconds. Typical dwell time is 4 seconds at 250 °C.

A mildly-activated flux will eliminate the need for removal of corrosive residues in most applications.

REPAIRING SOLDERED JOINTS

Fix the component by first soldering two diagonally-opposite end leads. Use only a low voltage soldering iron (less than 24 V) applied to the flat part of the lead. Contact time must be limited to 10 seconds at up to 300 °C. When using a dedicated tool, all other leads can be soldered in one operation within 2 to 5 seconds between 270 and 320 °C.

TV sound AM-demodulator and audio source switch

TDA9830

DEFINITIONS

Data sheet status	
Objective specification	This data sheet contains target or goal specifications for product development.
Preliminary specification	This data sheet contains preliminary data; supplementary data may be published later.
Product specification	This data sheet contains final product specifications.
Limiting values	
Limiting values given are in accordance with the Absolute Maximum Rating System (IEC 134). Stress above one or more of the limiting values may cause permanent damage to the device. These are stress ratings only and operation of the device at these or at any other conditions above those given in the Characteristics sections of the specification is not implied. Exposure to limiting values for extended periods may affect device reliability.	
Application information	
Where application information is given, it is advisory and does not form part of the specification.	

LIFE SUPPORT APPLICATIONS

These products are not designed for use in life support appliances, devices, or systems where malfunction of these products can reasonably be expected to result in personal injury. Philips customers using or selling these products for use in such applications do so at their own risk and agree to fully indemnify Philips for any damages resulting from such improper use or sale.