



Chipsmall Limited consists of a professional team with an average of over 10 year of expertise in the distribution of electronic components. Based in Hongkong, we have already established firm and mutual-benefit business relationships with customers from,Europe,America and south Asia,supplying obsolete and hard-to-find components to meet their specific needs.

With the principle of “Quality Parts,Customers Priority,Honest Operation,and Considerate Service”,our business mainly focus on the distribution of electronic components. Line cards we deal with include Microchip,ALPS,ROHM,Xilinx,Pulse,ON,Everlight and Freescale. Main products comprise IC,Modules,Potentiometer,IC Socket,Relay,Connector.Our parts cover such applications as commercial,industrial, and automotives areas.

We are looking forward to setting up business relationship with you and hope to provide you with the best service and solution. Let us make a better world for our industry!



Contact us

Tel: +86-755-8981 8866 Fax: +86-755-8427 6832

Email & Skype: info@chipsmall.com Web: www.chipsmall.com

Address: A1208, Overseas Decoration Building, #122 Zhenhua RD., Futian, Shenzhen, China





TDF8546

I²C-bus controlled 4 × 45 W best efficiency amplifier

Rev. 8 — 27 September 2013

Product short data sheet

1. General description

The TDF8546 is one of a new generation of complementary quad Bridge-Tied Load (BTL) audio power amplifiers intended for automotive applications. It has a best efficiency mode with full I²C-bus controlled diagnostics, including start-up diagnostics. The TDF8546 can operate at a battery voltage as low as 6 V making this amplifier suitable for stop/start-car operation.

The new best efficiency principle uses a patented switch technique which reduces switching distortion. To reduce power dissipation, the new best efficiency principle uses the audio information on all four channels instead of only the front or rear signals. Dissipation is more than 65 % less than standard BTL when used for front and rear correlated audio signals. Dissipation is 35 % less than standard BTL when used for uncorrelated (delayed) audio signals between front and rear. It is 17 % less for uncorrelated audio signals when the front or rear information is used.

The amplifier uses a complementary DMOS output stage in a Silicon-On-Insulator (SOI) based BCD process. The DMOS output stage ensures a high-power output signal with perfect sound quality. The SOI-based BCD process ensures a robust amplifier, where latch-up cannot occur, with good separation between the four independent channels, with every component isolated and without substrate currents.

2. Features and benefits

- Stop/start-car prepared: keeps operating without audible disturbance during engine start at a battery voltage as low as 6 V
- New best efficiency mode with patented low switching distortion
- Extreme best efficiency mode (uses information from 4 channels) with 17 % less dissipation for uncorrelated signals compared to 2-channel best efficiency mode.
- Operates in either legacy (non-I²C-bus) or I²C-bus modes (3.3 V and 5 V compliant)
- Four hardware-programmable I²C-bus addresses
- Can drive 2 Ω and 4 Ω loads
- Speaker fault detection
- Start-up diagnostics with load detection: open, short, present; filtered for door-slam and chatter relays
- AC load (tweeter) detection with low and high current mode
- Gain select after start-up without audible disturbance
- Independent selectable soft mute of front and rear channels
- Programmable gain (26 dB and 16 dB), independently programmable for the front and rear channels



- Line driver mode supports engine start at a battery voltage as low as 6 V (16 dB and mid-tap voltage $0.25 \times V_P$)
- Programmable clip detect: 2 %, 5 % or 10 %
- Programmable thermal pre-warning
- Pin STB can be programmed/multiplexed with second-clip detect
- Clip information of each channel can be directed separately to pin DIAG or pin STB
- Independent enabling of thermal-, clip- or load fault information (short across the load or to V_P or to ground) on pin DIAG
- Loss-of-ground and open V_P safe (minimum series resistance required)
- All amplifier outputs short-circuit proof to ground, supply voltage and across the load (channel independent)
- All pins short-circuit proof to ground
- Temperature controlled gain reduction to prevent audio holes at high junction temperatures
- Programmable low battery voltage detection to enable 7.5 V or 6 V minimum battery voltage operation
- Overvoltage protection (load-dump safe up to $V_P = 50$ V) with overvoltage pre-warning at 16 V
- Offset detection

3. Quick reference data

Table 1. Quick reference data

Symbol	Parameter	Conditions	Min	Typ	Max	Unit
$V_{P(oper)}$	operating supply voltage	$R_L = 4 \Omega$	6	14.4	18	V
I_q	quiescent current	no load	-	260	350	mA
		no load; $V_P = 7$ V	-	190	-	mA
P_o	output power	$R_L = 4 \Omega$; $V_P = 14.4$ V; maximum power; $V_i = 2$ V RMS square wave	37	40	-	W
		$R_L = 4 \Omega$; $V_P = 15.2$ V; maximum power; $V_i = 2$ V RMS square wave	41	45	-	W
		$R_L = 4 \Omega$; $V_P = 14.4$ V; THD = 0.5 %	18	20	-	W
		$R_L = 4 \Omega$; $V_P = 14.4$ V; THD = 10 %	23	25	-	W
		$R_L = 2 \Omega$; $V_P = 14.4$ V; THD = 10 %	40	44	-	W
		$R_L = 2 \Omega$; $V_P = 14.4$ V; maximum power; $V_i = 2$ V RMS square wave	58	64	-	W
THD	total harmonic distortion	$P_o = 1$ W to 12 W; $f_i = 1$ kHz; $R_L = 4 \Omega$; BTL mode	-	0.01	0.1	%
		$P_o = 4$ W; $f_i = 1$ kHz; $R_L = 4 \Omega$; best efficiency mode	-	0.03	-	%
$V_{n(o)}$	output noise voltage	filter 20 Hz to 22 kHz; $R_S = 1$ k Ω				
		amplifier mode	-	43	65	μ V
		line driver mode	-	25	33	μ V

4. Ordering information

Table 2. Ordering information

Type number	Package		
	Name	Description	Version
TDF8546J	DBS27P	plastic DIL-bent-SIL (special bent) power package; 27 leads (lead length 6.8 mm)	SOT827-1
TDF8546TH	HSOP36	plastic, heatsink small outline package; 36 leads; low stand-off height	SOT851-1
TDF8546JS	DBSMS27P	plastic dual bent surface mounted SIL power package; 27 leads	SOT1154-1

5. Pinning information

5.1 Pinning

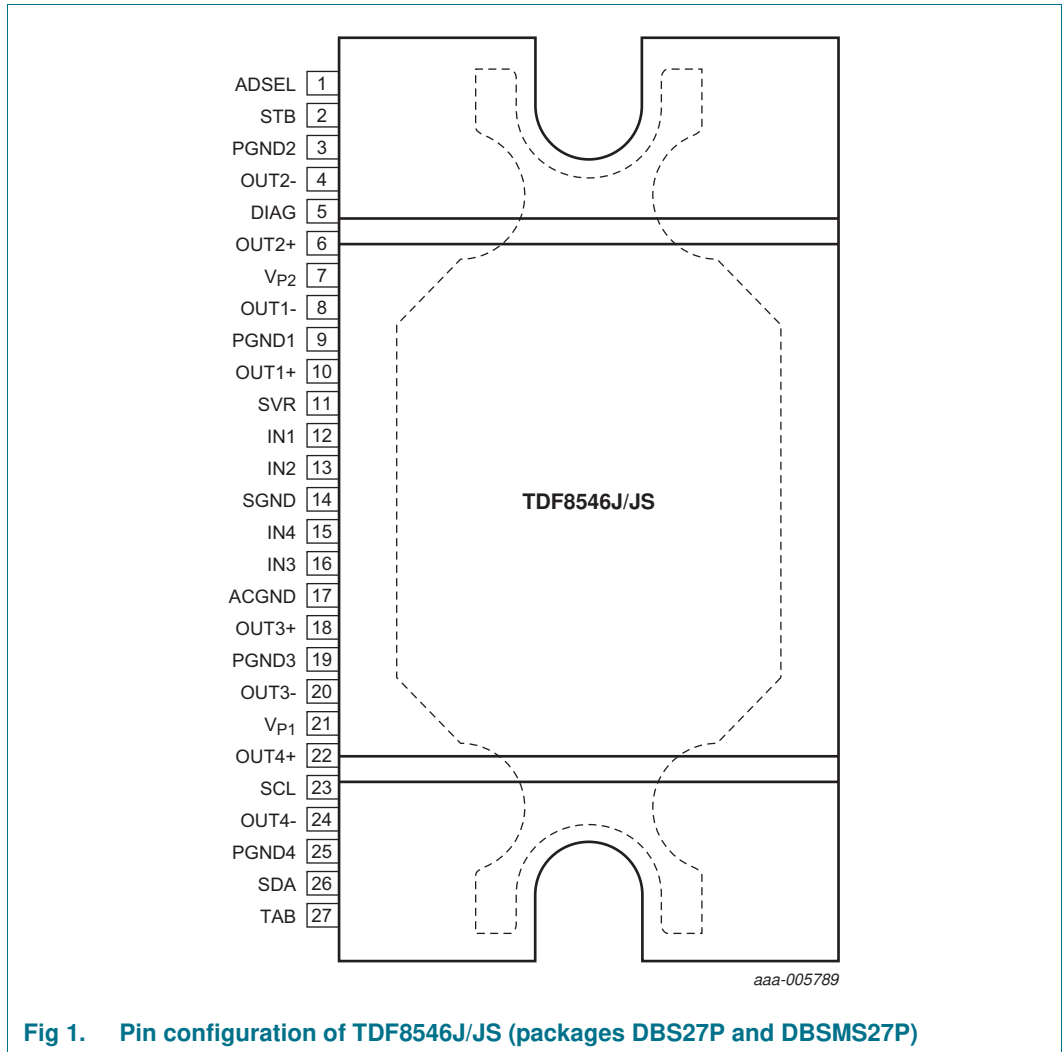

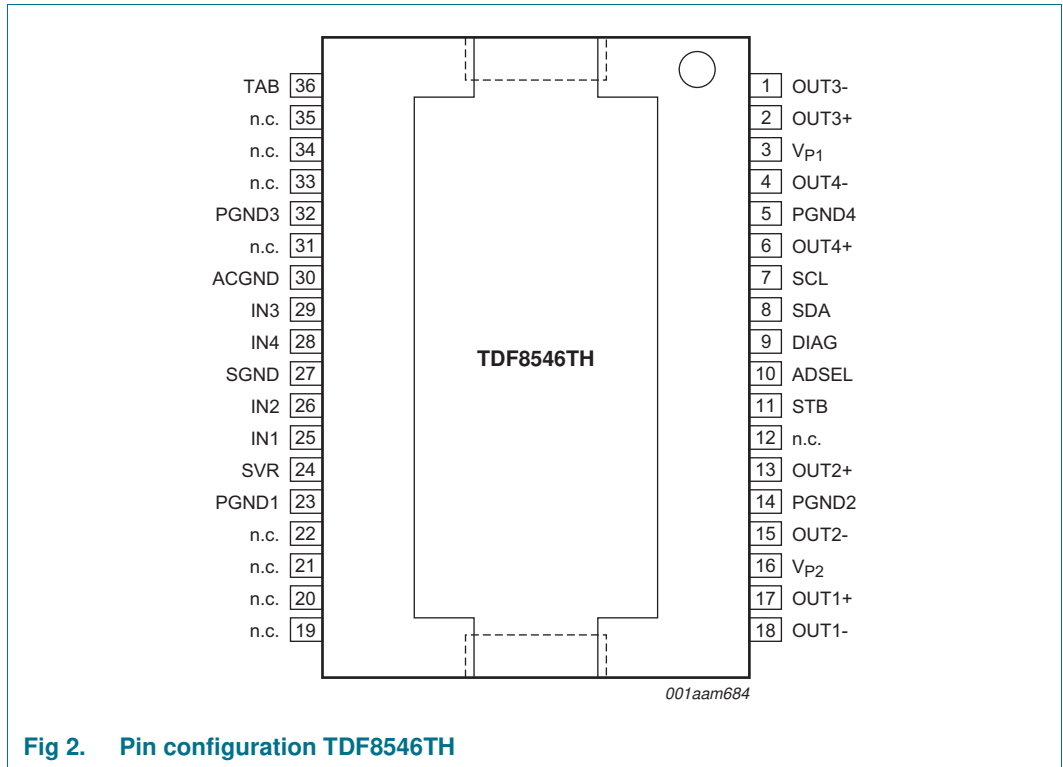

Fig 2. Pin configuration TDF8546TH

5.2 Pin description

Table 3. Pin description

Symbol	Pin		Description
	TDF8546J/JS	TDF8546TH	
ADSEL	1	10	I ² C-bus address select
STB	2	11	Standby (I ² C-bus mode) or mode pin (legacy mode) programmable second clip indicator
PGND2	3	14	channel 2 power ground
OUT2-	4	15	channel 2 negative output (right rear)
DIAG	5	9	diagnostic and clip detection output
OUT2+	6	13	channel 2 positive output (right rear)
V _{P2}	7	16	power supply voltage 2
OUT1-	8	18	channel 1 negative output (right front)
PGND1	9	23	channel 1 power ground
OUT1+	10	17	channel 1 positive output (right front)
SVR	11	24	half supply voltage filter capacitor
IN1	12	25	channel 1 input
IN2	13	26	channel 2 input
SGND	14	27	signal ground
IN4	15	28	channel 4 input
IN3	16	29	channel 3 input
ACGND	17	30	AC ground
OUT3+	18	2	channel 3 positive output (left front)
PGND3	19	32	channel 3 power ground
OUT3-	20	1	channel 3 negative output (left front)
V _{P1}	21	3	power supply voltage 1
OUT4+	22	6	channel 4 positive output (left rear)
SCL	23	7	I ² C-bus clock input
OUT4-	24	4	channel 4 negative output (left rear)
PGND4	25	5	channel 4 power ground
SDA	26	8	I ² C-bus data input and output
TAB	27	36	heatsink connection; must be connected to ground
n.c.	-	12, 19, 20, 21, 22, 31, 33, 34, 35	not connected

6. Thermal characteristics

Table 4. Thermal characteristics

Symbol	Parameter	Conditions	Typ	Unit
DBS27/DBSMS27P				
$R_{th(j-c)}$	thermal resistance from junction to case		1	K/W
$R_{th(j-a)}$	thermal resistance from junction to ambient		40	K/W
HSOP36				
$R_{th(j-c)}$	thermal resistance from junction to case		1	K/W
$R_{th(j-a)}$	thermal resistance from junction to ambient		35	K/W

7. Characteristics

Table 5. Characteristics

$T_{amb} = 25\text{ °C}$; $V_P = 14.4\text{ V}$; unless otherwise specified. Tested at $T_{amb} = 25\text{ °C}$; guaranteed for $T_j = -40\text{ °C}$ to $+150\text{ °C}$; functionality is guaranteed for $V_P < 10\text{ V}$ unless otherwise specified.

Symbol	Parameter	Conditions	Min	Typ	Max	Unit
Supply voltage behavior						
$V_{P(oper)}$	operating supply voltage	$R_L = 4\ \Omega$	6	14.4	18	V
		$R_L = 2\ \Omega$	6	14.4	16	V
I_q	quiescent current	no load	-	260	350	mA
		no load; $V_P = 7\text{ V}$	-	190	-	mA
I_{off}	off-state current	$V_{STB} = 0.4\text{ V}$	-	4	10	μA
V_O	output voltage	DC				
		amplifier on; high gain/low gain mode	6.6	7.1	7.6	V
		line driver mode; $IB4[D2] = 0$; $IB3[D5:D6] = 1$	3.0	3.4	3.8	V
$V_{P(low)(mute)}$	low supply voltage mute	rising supply voltage				
		$IB4[D0] = 1$	7.0	7.7	8.1	V
		$IB4[D0] = 0$	5.4	5.7	6.2	V
		falling supply voltage				
		$IB4[D0] = 1$	6.5	7.2	7.7	V
$\Delta V_{P(low)(mute)}$	low supply voltage mute hysteresis	$IB4[D0] = 1$	0.1	0.5	0.8	V
		$IB4[D0] = 0$	0.1	0.3	0.7	V
$V_{P(ovp)pwarn}$	pre-warning overvoltage protection supply voltage	rising supply voltage	15.2	16	16.9	V
		falling supply voltage	14.4	15.2	16.2	V
		hysteresis	-	0.8	-	V
$V_{th(ovp)}$	overvoltage protection threshold voltage	rising supply voltage	18	20	22	V
V_{POR}	power-on reset voltage	falling supply voltage	-	3.1	4.5	V
$V_{O(offset)}$	output offset voltage	amplifier on	-75	0	+75	mV
		amplifier mute	-25	0	+25	mV
		line driver mode	-45	0	+45	mV

Table 5. Characteristics ...continued

$T_{amb} = 25\text{ °C}$; $V_P = 14.4\text{ V}$; unless otherwise specified. Tested at $T_{amb} = 25\text{ °C}$; guaranteed for $T_j = -40\text{ °C}$ to $+150\text{ °C}$; functionality is guaranteed for $V_P < 10\text{ V}$ unless otherwise specified.

Symbol	Parameter	Conditions	Min	Typ	Max	Unit
Mode select and second clip detection: pin STB						
V_{STB}	voltage on pin STB	off-by mode selected				
		I ² C-bus mode	-	-	0.8	V
		legacy mode (I ² C-bus mode off)	-	-	0.8	V
		mute selected				
		legacy mode (I ² C-bus mode off)	2.5	-	4.5	V
		operating mode selected				
		I ² C-bus mode	2.5	-	V_P	V
		legacy mode (I ² C-bus mode off)	5.9	-	V_P	V
		low voltage on pin STB when pulled LOW during clipping; clip detection on STB active	[1]			
$I_{STB} = 150\text{ }\mu\text{A}$	5.6	5.9	6.5	V		
$I_{STB} = 500\text{ }\mu\text{A}$	6.1	-	7.4	V		
I_{STB}	current on pin STB	$0\text{ V} < V_{STB} < 8.5\text{ V}$; clip detection not active	[1]	-	5	30 μA
Start-up/shut-down/mute timing						
t_{wake}	wake-up time	time after wake-up via pin STB before first I ² C-bus transmission is recognized;	-	300	500	μs
$I_{LO(SVR)}$	output leakage current on pin SVR		-	-	5	μA
$t_{d(mute_off)}$	mute off delay time	time from amplifier start to 10 % of output signal; $I_{LO} = 0\text{ }\mu\text{A}$	[2]			
		I ² C-bus mode; with $I_{LO} = 5\text{ }\mu\text{A} \rightarrow +15\text{ ms}$; no DC-load ($IB1[D1] = 0$);	-	430	650	ms
		legacy mode; with $I_{LO} = 5\text{ }\mu\text{A} \rightarrow +20\text{ ms}$; $V_{STB} = 7\text{ V}$; $R_{ADSEL} = 0\text{ }\Omega$;	-	430	650	ms
t_{amp_on}	amplifier on time	time from amplifier start to amplifier on; 90 % of output signal; $I_{LO} = 0\text{ }\mu\text{A}$	[2]			
		I ² C-bus mode; with $I_{LO} = 5\text{ }\mu\text{A} \rightarrow +30\text{ ms}$; no DC-load ($IB1[D1] = 0$);	-	550	800	ms
		legacy mode; with $I_{LO} = 5\text{ }\mu\text{A} \rightarrow +20\text{ ms}$; $V_{STB} = 7\text{ V}$; $R_{ADSEL} = 0\text{ }\Omega$;	-	550	800	ms

Table 5. Characteristics ...continued

$T_{amb} = 25\text{ °C}$; $V_P = 14.4\text{ V}$; unless otherwise specified. Tested at $T_{amb} = 25\text{ °C}$; guaranteed for $T_j = -40\text{ °C}$ to $+150\text{ °C}$; functionality is guaranteed for $V_P < 10\text{ V}$ unless otherwise specified.

Symbol	Parameter	Conditions	Min	Typ	Max	Unit
t_{off}	amplifier switch-off time	time to DC output voltage $< 0.1\text{ V}$; [2] $I_{LO} = 0\text{ }\mu\text{A}$				
		I ² C-bus mode; with $I_{LO} = 5\text{ }\mu\text{A} \rightarrow +0\text{ ms}$;	250	500	750	ms
		via pin STB; (IB4[D6] = 0); with $I_{LO} = 5\text{ }\mu\text{A} \rightarrow +0\text{ ms}$;	250	500	750	ms
$t_{d(mute-on)}$	delay time from mute to on	from 10 % to 90 % of output signal; $V_i = 50\text{ mV}$; I ² C-bus mode (IB2[D1, D2] = 1 to 0) or IB2(D0 = 1 to 0) or legacy mode ($V_{STB} = 3\text{ V}$ to 7 V);	5	15	40	ms
$t_{d(soft_mute)}$	soft mute delay time	from 90 % to 10 % of output signal; $V_i = 50\text{ mV}$; I ² C-bus mode (IB2[D1, D2] = 0 to 1) or legacy mode ($V_{STB} = 7\text{ V}$ to 3 V);	5	15	40	ms
$t_{d(fast_mute)}$	fast mute delay time	from 90 % to 10 % of output signal; $V_i = 50\text{ mV}$; I ² C-bus mode (IB2[D0] = 0 to 1, or V_{STB} from $> 5.9\text{ V}$ to $< 0.8\text{ V}$ in $1\text{ }\mu\text{s}$;	-	0.4	1	ms
$t_{(start-Vo(off))}$	engine start to output off time	V_P from 14.4 V to 5 V in 1.5 ms ; $V_o < 0.5\text{ V}$;	-	0.1	1	ms
$t_{(start-SVRoff)}$	engine start to SVR off time	V_P from 14.4 V to 5 V in 1.5 ms ; $V_{SVR} < 0.7\text{ V}$;	-	40	75	ms
I²C-bus interface [3]						
V_{IL}	LOW-level input voltage	pins SCL and SDA	-	-	1.5	V
V_{IH}	HIGH-level input voltage	pins SCL and SDA	2.3		5.5	V
V_{OL}	LOW-level output voltage	pin SDA; $I_L = 5\text{ mA}$	-	-	0.4	V
f_{SCL}	SCL clock frequency		-	400	-	kHz
V_{ADSEL}	voltage on pin ADSEL	I ² C-bus address $A[6:0] = 1101\ 101$				
		$R_{seriesADSEL} = 0\text{ }\Omega$	4	5	11	V
		$R_{seriesADSEL} = 100\text{ k}\Omega$	-	-	V_P	V
$I_{I(ADSEL)}$	input current on pin ADSEL	$V_{STB} = 5\text{ V}$; $V_{ADSEL} = 5\text{ V}$	-	2	10	μA
R_{ADSEL}	resistance on pin ADSEL	I ² C-bus address $A[6:0] = 1101\ 110$	99	100	101	$\text{k}\Omega$
		I ² C-bus address $A[6:0] = 1101\ 111$	29.7	30	30.3	$\text{k}\Omega$
		I ² C-bus address $A[6:0] = 1101\ 010$	9.9	10	10.1	$\text{k}\Omega$
		legacy mode	-	-	0.47	$\text{k}\Omega$
$V_{P(latch)}$	latch supply voltage	does not react to address selection changes	-	-	6	V

Start-up diagnostics

Table 5. Characteristics ...continued

$T_{amb} = 25\text{ °C}$; $V_P = 14.4\text{ V}$; unless otherwise specified. Tested at $T_{amb} = 25\text{ °C}$; guaranteed for $T_j = -40\text{ °C}$ to $+150\text{ °C}$; functionality is guaranteed for $V_P < 10\text{ V}$ unless otherwise specified.

Symbol	Parameter	Conditions	Min	Typ	Max	Unit
t_{sudiag}	start-up diagnostic time	from start-up diagnostic command via I ² C-bus until completion of start-up diagnostic; $V_O + < 0.1\text{ V}$; $V_O - < 0.1\text{ V}$ (no load) IB1[D1] = 1;	50	130	250	ms
$t_{d(sudiag-on)}$	start-up diagnostic to on delay time	at 90 % of output signal; IB1[D0:D1] = 11;	-	680	-	ms
V_{offset}	offset voltage	start-up diagnostic offset voltage under no load condition	1.3	2	2.5	V
$R_{Ldet(sudiag)}$	start-up diagnostic load detection resistance	shorted load				
		high gain; IB3[D6:D5] = 00	-	-	0.5	Ω
		low gain; IB3[D6:D5] = 11	-	-	1.5	Ω
		normal load				
		high gain (IB3[D6:D5] = 00)	1.5	-	20	Ω
		low gain (IB3[D6:D5] = 11)	3.2	-	20	Ω
		line driver load	80	-	200	Ω
		open load	400	-	-	Ω
Amplifier diagnostics						
$V_{OL(DIAG)}$	LOW-level output voltage on pin DIAG	fault condition; $I_{DIAG} = 1\text{ mA}$	-	-	0.3	V
$V_{O(offset_det)}$	output voltage at offset detection		±1.0	±1.3	±2.0	V
THD_{clip}	total harmonic distortion clip detection level	$V_P > 10\text{ V}$				
		IB2[D7:D6] = 10	-	10	-	%
		IB2[D7:D6] = 01	-	5	-	%
		IB2[D7:D6] = 00	-	2	-	%
$T_{j(AV)(pwarn)}$	pre-warning average junction temperature	IB3[D4] = 0 or legacy mode	150	160	170	°C
		IB3[D4] = 1	125	135	145	°C
$T_{j(AV)(G(-0.5dB))}$	average junction temperature for 0.5 dB gain reduction	$V_i = 0.05\text{ V}$; best efficiency mode turns off when activated	-	175	-	°C
$\Delta G_{(th_fold)}$	gain reduction of thermal foldback	when all channels switch off	-	20	-	dB
I_o	output current	I ² C-bus mode; IB5[D7] = 0; AC load bit set; peak current				
		IB4[D1] = 1	500	-	-	mA
		IB4[D1] = 0	275	-	-	mA
		I ² C-bus mode; IB5[D7] = 0; AC load bit not set; peak current				
		IB4[D1] = 1	-	-	250	mA
		IB4[D1] = 0	-	-	100	mA

Table 5. Characteristics ...continued

$T_{amb} = 25\text{ °C}$; $V_P = 14.4\text{ V}$; unless otherwise specified. Tested at $T_{amb} = 25\text{ °C}$; guaranteed for $T_j = -40\text{ °C}$ to $+150\text{ °C}$; functionality is guaranteed for $V_P < 10\text{ V}$ unless otherwise specified.

Symbol	Parameter	Conditions	Min	Typ	Max	Unit	
Amplifier							
P_o	output power	$R_L = 4\ \Omega$; $V_P = 14.4\text{ V}$; THD = 0.5 %	18	20	-	W	
		$R_L = 4\ \Omega$; $V_P = 14.4\text{ V}$; THD = 10 %	23	25	-	W	
		$R_L = 2\ \Omega$; $V_P = 14.4\text{ V}$; THD = 0.5 %	29	32	-	W	
		$R_L = 2\ \Omega$; $V_P = 14.4\text{ V}$; THD = 10 %	40	44	-	W	
$P_{o(max)}$	maximum output power	$R_L = 4\ \Omega$; $V_P = 14.4\text{ V}$; $V_i = 2\text{ V RMS square wave}$	37	40	-	W	
		$R_L = 4\ \Omega$; $V_P = 15.2\text{ V}$; $V_i = 2\text{ V RMS square wave}$	41	45	-	W	
		$R_L = 2\ \Omega$; $V_P = 14.4\text{ V}$; $V_i = 2\text{ V RMS square wave}$	58	64	-	W	
THD	total harmonic distortion	$P_o = 1\text{ W to }12\text{ W}$; $f_i = 1\text{ kHz}$; $R_L = 4\ \Omega$; BTL mode	-	0.01	0.1	%	
		$P_o = 1\text{ W}$; $f_i = 1\text{ kHz}$; $R_L = 4\ \Omega$; $V_P = 7\text{ V}$; BTL and best efficiency mode	-	0.01	0.1	%	
		$P_o = 4\text{ W}$; $f_i = 1\text{ kHz}$; $R_L = 4\ \Omega$; best efficiency mode	-	0.03	0.1	%	
		$P_o = 1\text{ W to }12\text{ W}$; $f_i = 20\text{ kHz}$; $R_L = 4\ \Omega$; best efficiency mode	-	0.3	0.4	%	
		$V_o = 1\text{ V (RMS)}$ and 4 V (RMS) , $f_i = 1\text{ kHz}$; line driver mode	-	0.02	0.05	%	
		$P_o = 1\text{ W to }12\text{ W}$; $f_i = 1\text{ kHz}$; $R_L = 4\ \Omega$; low gain mode	-	0.01	0.1	%	
α_{cs}	channel separation	best efficiency mode; $R_S = 1\text{ k}\Omega$; $R_{ACGND} = 250\ \Omega$	[4]				
		$f_i = 1\text{ kHz}$	65	80	-	dB	
		$f_i = 10\text{ kHz}$	55	65	-	dB	
SVRR	supply voltage ripple rejection	$f_i = 1\text{ kHz}$; $R_S = 1\text{ k}\Omega$; $R_{ACGND} = 250\ \Omega$; best efficiency mode; tested at $V_P = 10.5\text{ V}$	[4]	55	70	-	dB
CMRR	common mode rejection ratio	amplifier mode; $V_{cm} = 0.3\text{ V (p-p)}$; $f_i = 1\text{ kHz to }3\text{ kHz}$, $R_S = 1\text{ k}\Omega$; $R_{ACGND} = 250\ \Omega$; best efficiency mode	[4]				
		common mode input to differential output ($V_{O(dif)}$ / $V_{I(cm)}$) + 26 dB)	55	65	-	dB	
		common mode input to common mode output ($V_{O(cm)}$ / $V_{I(cm)}$) + 26 dB)	50	58	-	dB	

Table 5. Characteristics ...continued

$T_{amb} = 25\text{ °C}$; $V_P = 14.4\text{ V}$; unless otherwise specified. Tested at $T_{amb} = 25\text{ °C}$; guaranteed for $T_j = -40\text{ °C}$ to $+150\text{ °C}$; functionality is guaranteed for $V_P < 10\text{ V}$ unless otherwise specified.

Symbol	Parameter	Conditions	Min	Typ	Max	Unit
ΔV_o	output voltage variation	plop during switch-on and switch-off; best efficiency mode	[5]			
		from off to mute and mute to off	-	-	7.5	mV
		from mute to on and on to mute (soft mute)	-	-	7.5	mV
		from off to on and on to off (start-up diagnostic enabled)	-	-	7.5	mV
$V_{n(o)}$	output noise voltage	filter 20 Hz to 22 kHz (6 th order); $R_S = 1\text{ k}\Omega$				
		mute mode	-	15	23	μV
		line driver mode	-	25	33	μV
		amplifier mode; best efficiency mode	-	43	65	μV
		amplifier mode; best efficiency mode; $R_S = 50\ \Omega$	-	40	60	μV
$G_{v(\text{amp})}$	voltage gain amplifier mode	single-ended in to differential out; best efficiency mode	25.5	26	26.5	dB
$G_{v(\text{ld})}$	voltage gain line driver mode	single-ended in to differential out; best efficiency mode	15.5	16	16.5	dB
Z_i	input impedance	$T_{amb} = -40\text{ °C}$ to $+105\text{ °C}$	38	62	105	$\text{k}\Omega$
		$T_{amb} = 0\text{ °C}$ to 105 °C	55	62	105	$\text{k}\Omega$
α_{mute}	mute attenuation	$V_{o(\text{on})} / V_{o(\text{mute})}$; $V_i = 50\text{ mV}$	80	92	-	dB
$V_{o(\text{mute})(\text{RMS})}$	RMS mute output voltage	$V_i = 1\text{ V RMS}$; filter 20 Hz to 22 kHz	-	16	29	μV
B_p	power bandwidth	-1 dB	-	20 to 20000	-	Hz
$C_{L(\text{crit})}$	critical load capacitance	no oscillation; R_L between $2\ \Omega$ and open load; C_L from all outputs to GND	22	-	-	nF

Best efficiency mode control

$V_{o(\text{swoff})\text{be}}$	best efficiency switch-off output voltage	best efficiency switch open				
		4 Ω load selected; IB5[D4] = 1	-	0.9	-	V
		2 Ω load selected; IB5[D4] = 0	-	1.7	-	V
$R_{\text{sw}(\text{be})}$	best efficiency switch resistance		-	1.0	-	Ω

- [1] V_{STB} depends on the current into pin STB: minimum = $(1429\ \Omega \times I_{\text{STB}}) + 5.4\text{ V}$, maximum = $(3143\ \Omega \times I_{\text{STB}}) + 5.6\text{ V}$.
- [2] The times are specified without leakage current. For a leakage current of $5\ \mu\text{A}$ on pin SVR, the delta time is specified. If the capacitor value on pin SVR changes $\pm 30\%$, the specified time also changes $\pm 30\%$. The specified times include an ESR of $15\ \Omega$ for the capacitor on pin SVR.
- [3] Standard I²C-bus specification: maximum LOW-level = $0.3V_{\text{DD}}$, minimum HIGH-level = $0.7V_{\text{DD}}$. To comply with 5 V and 3.3 V logic, $V_{\text{DD}} = 5\text{ V}$ defines the maximum LOW-level and $V_{\text{DD}} = 3.3\text{ V}$ defines the minimum HIGH-level.
- [4] For optimum channel separation (α_{cs}), supply voltage ripple rejection (SVRR) and common mode rejection ratio (CMRR), a resistor

$$R_{\text{ACGND}} = \frac{R_S}{4}\ \Omega \text{ must be in series with the ACGND capacitor.}$$

- [5] The plop-noise during amplifier switch-on and switch-off is measured using an ITU-R 2 k filter; see [Figure 4](#).

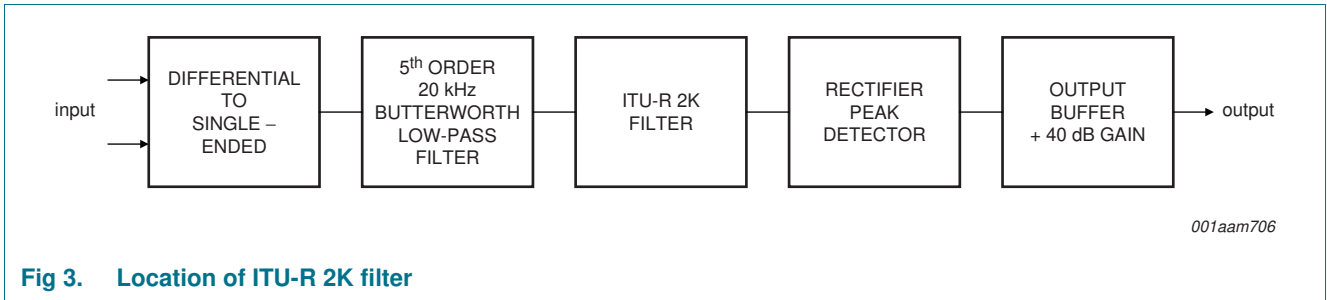

Fig 3. Location of ITU-R 2K filter

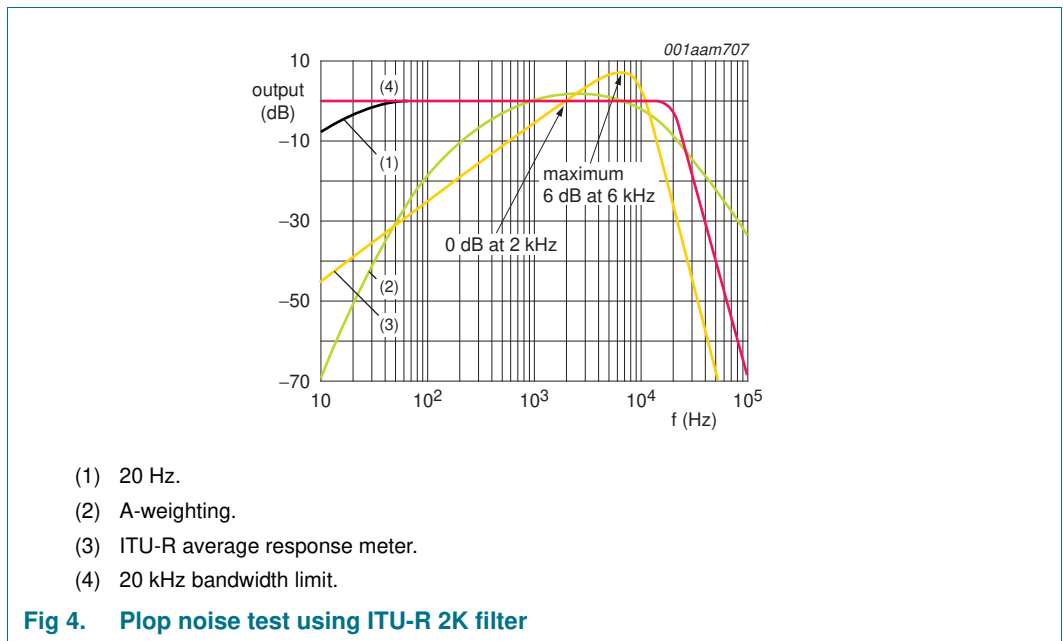

Fig 4. Plop noise test using ITU-R 2K filter

8. Package outline

DBS27P: plastic DIL-bent-SIL (special bent) power package; 27 leads (lead length 6.8 mm)

SOT827-1

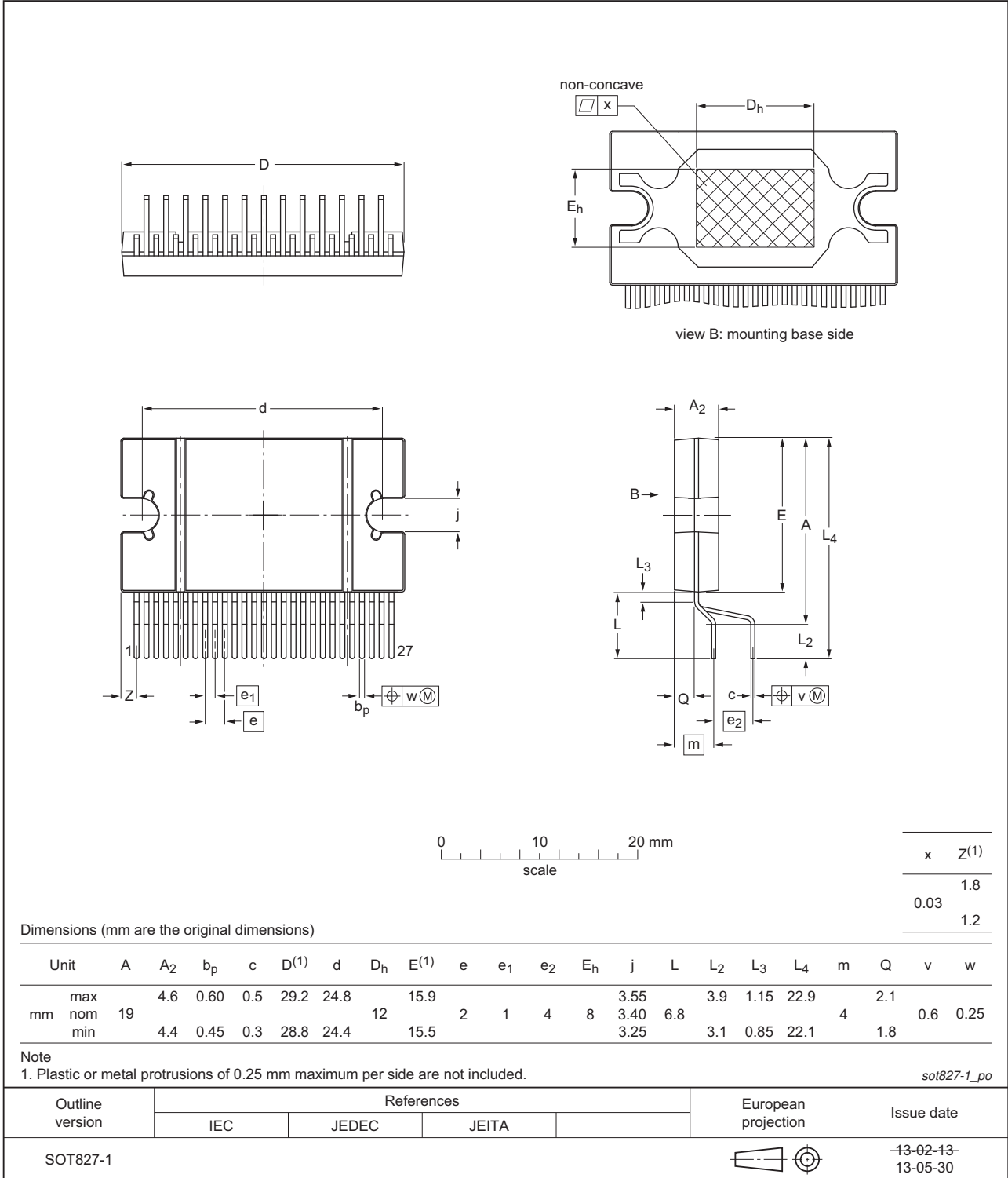

Fig 5. Package outline SOT827-1 (DBS27P)

HSOP36: plastic, heatsink small outline package; 36 leads; low stand-off height

SOT851-1

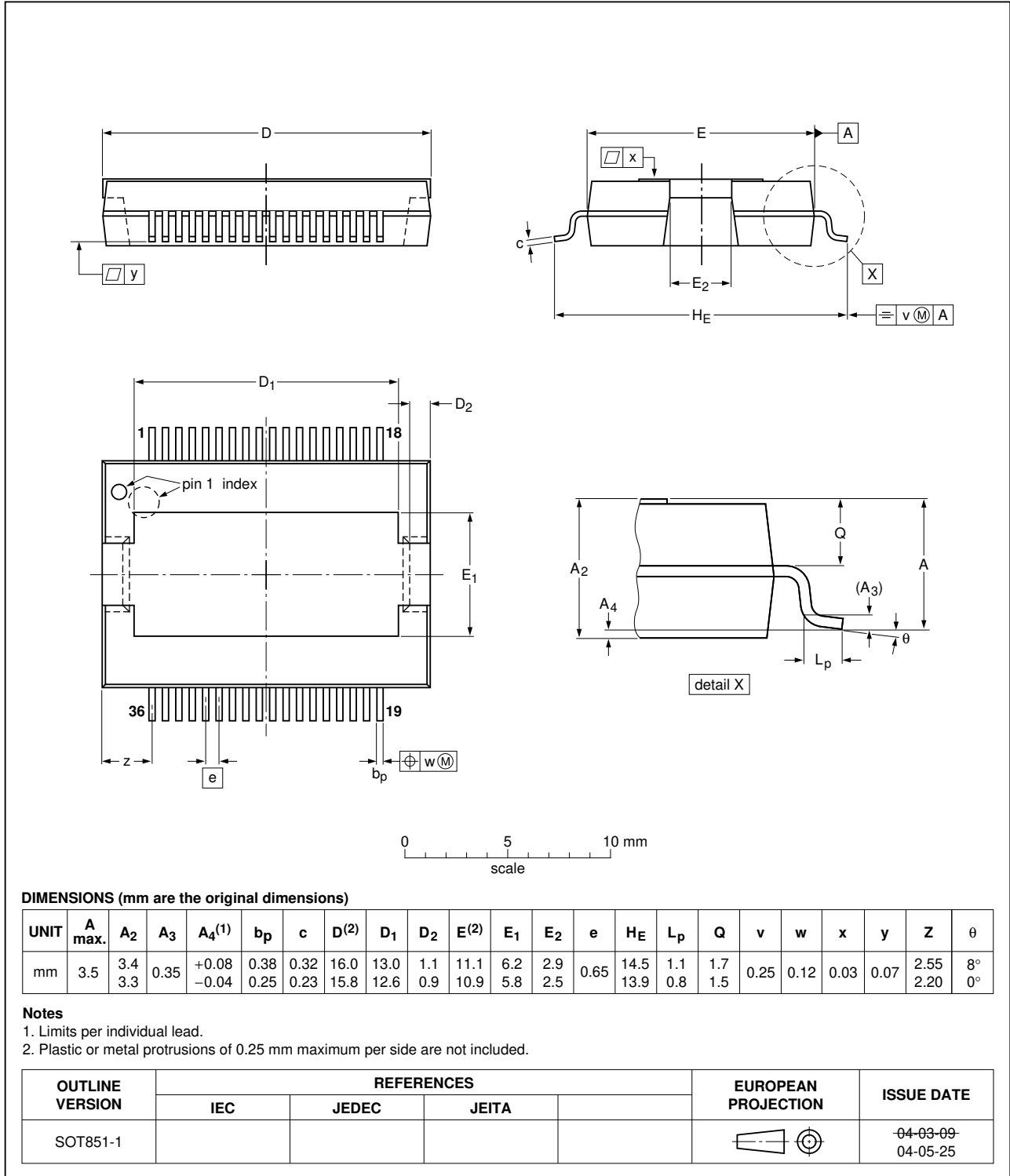

Fig 6. Package outline SOT851-1 (HSOP36)

DBSMS27P: plastic dual bent surface mounted SIL power package; 27 leads

SOT1154-1

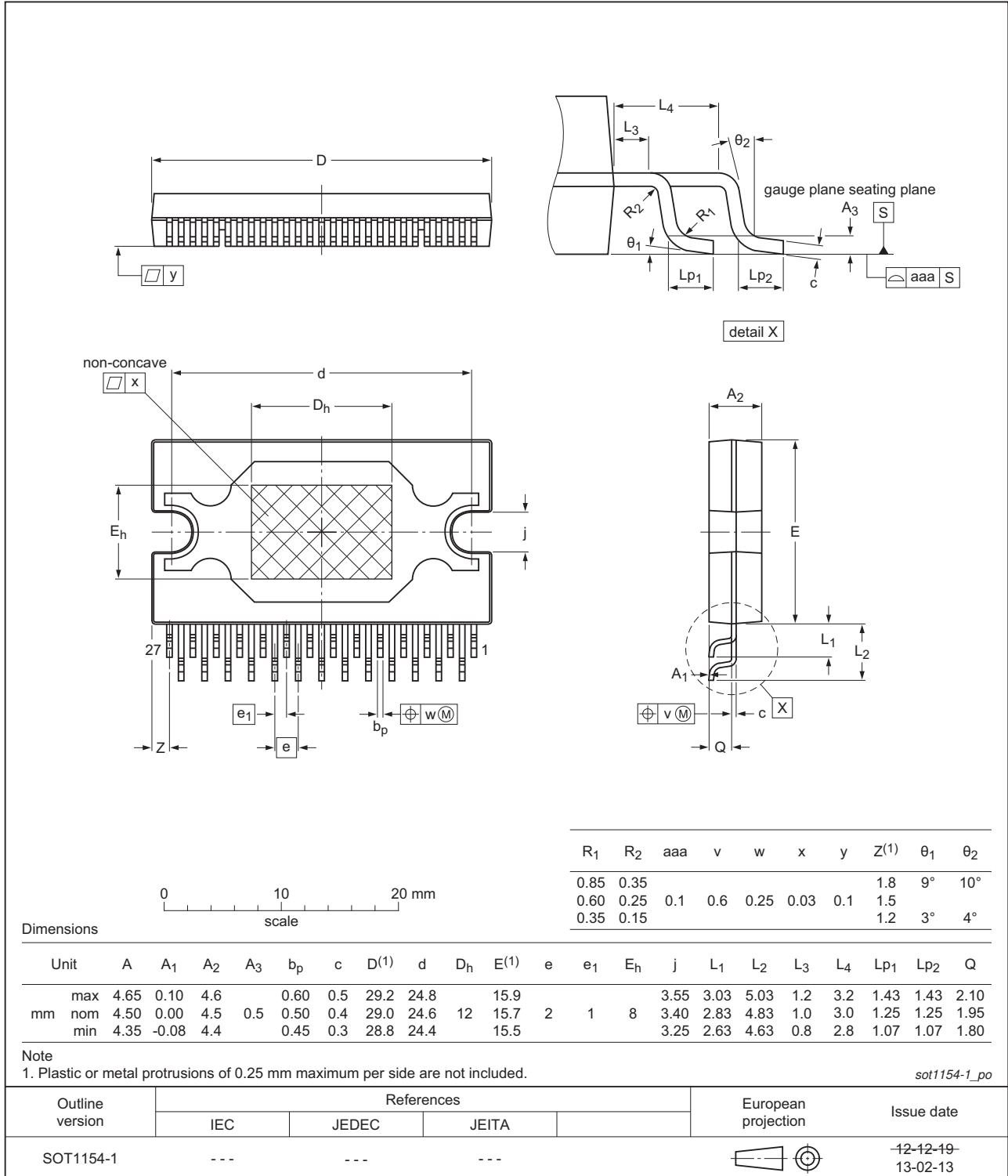

Fig 7. Package outline SOT1154-1 (DBSMS27P)

9. Revision history

Table 6. Revision history

Document ID	Release date	Data sheet status	Change notice	Supersedes
TDF8546 v.8	20130927	Product short data sheet	-	-

10. Legal information

10.1 Data sheet status

Document status ^{[1][2]}	Product status ^[3]	Definition
Objective [short] data sheet	Development	This document contains data from the objective specification for product development.
Preliminary [short] data sheet	Qualification	This document contains data from the preliminary specification.
Product [short] data sheet	Production	This document contains the product specification.

[1] Please consult the most recently issued document before initiating or completing a design.

[2] The term 'short data sheet' is explained in section "Definitions".

[3] The product status of device(s) described in this document may have changed since this document was published and may differ in case of multiple devices. The latest product status information is available on the Internet at URL <http://www.nxp.com>.

10.2 Definitions

Draft — The document is a draft version only. The content is still under internal review and subject to formal approval, which may result in modifications or additions. NXP Semiconductors does not give any representations or warranties as to the accuracy or completeness of information included herein and shall have no liability for the consequences of use of such information.

Short data sheet — A short data sheet is an extract from a full data sheet with the same product type number(s) and title. A short data sheet is intended for quick reference only and should not be relied upon to contain detailed and full information. For detailed and full information see the relevant full data sheet, which is available on request via the local NXP Semiconductors sales office. In case of any inconsistency or conflict with the short data sheet, the full data sheet shall prevail.

Product specification — The information and data provided in a Product data sheet shall define the specification of the product as agreed between NXP Semiconductors and its customer, unless NXP Semiconductors and customer have explicitly agreed otherwise in writing. In no event however, shall an agreement be valid in which the NXP Semiconductors product is deemed to offer functions and qualities beyond those described in the Product data sheet.

10.3 Disclaimers

Limited warranty and liability — Information in this document is believed to be accurate and reliable. However, NXP Semiconductors does not give any representations or warranties, expressed or implied, as to the accuracy or completeness of such information and shall have no liability for the consequences of use of such information. NXP Semiconductors takes no responsibility for the content in this document if provided by an information source outside of NXP Semiconductors.

In no event shall NXP Semiconductors be liable for any indirect, incidental, punitive, special or consequential damages (including - without limitation - lost profits, lost savings, business interruption, costs related to the removal or replacement of any products or rework charges) whether or not such damages are based on tort (including negligence), warranty, breach of contract or any other legal theory.

Notwithstanding any damages that customer might incur for any reason whatsoever, NXP Semiconductors' aggregate and cumulative liability towards customer for the products described herein shall be limited in accordance with the *Terms and conditions of commercial sale* of NXP Semiconductors.

Right to make changes — NXP Semiconductors reserves the right to make changes to information published in this document, including without limitation specifications and product descriptions, at any time and without notice. This document supersedes and replaces all information supplied prior to the publication hereof.

Suitability for use in automotive applications — This NXP Semiconductors product has been qualified for use in automotive applications. Unless otherwise agreed in writing, the product is not designed, authorized or warranted to be suitable for use in life support, life-critical or safety-critical systems or equipment, nor in applications where failure or malfunction of an NXP Semiconductors product can reasonably be expected to result in personal injury, death or severe property or environmental damage. NXP Semiconductors and its suppliers accept no liability for inclusion and/or use of NXP Semiconductors products in such equipment or applications and therefore such inclusion and/or use is at the customer's own risk.

Applications — Applications that are described herein for any of these products are for illustrative purposes only. NXP Semiconductors makes no representation or warranty that such applications will be suitable for the specified use without further testing or modification.

Customers are responsible for the design and operation of their applications and products using NXP Semiconductors products, and NXP Semiconductors accepts no liability for any assistance with applications or customer product design. It is customer's sole responsibility to determine whether the NXP Semiconductors product is suitable and fit for the customer's applications and products planned, as well as for the planned application and use of customer's third party customer(s). Customers should provide appropriate design and operating safeguards to minimize the risks associated with their applications and products.

NXP Semiconductors does not accept any liability related to any default, damage, costs or problem which is based on any weakness or default in the customer's applications or products, or the application or use by customer's third party customer(s). Customer is responsible for doing all necessary testing for the customer's applications and products using NXP Semiconductors products in order to avoid a default of the applications and the products or of the application or use by customer's third party customer(s). NXP does not accept any liability in this respect.

Limiting values — Stress above one or more limiting values (as defined in the Absolute Maximum Ratings System of IEC 60134) will cause permanent damage to the device. Limiting values are stress ratings only and (proper) operation of the device at these or any other conditions above those given in the Recommended operating conditions section (if present) or the Characteristics sections of this document is not warranted. Constant or repeated exposure to limiting values will permanently and irreversibly affect the quality and reliability of the device.

Terms and conditions of commercial sale — NXP Semiconductors products are sold subject to the general terms and conditions of commercial sale, as published at <http://www.nxp.com/profile/terms>, unless otherwise agreed in a valid written individual agreement. In case an individual agreement is concluded only the terms and conditions of the respective agreement shall apply. NXP Semiconductors hereby expressly objects to applying the customer's general terms and conditions with regard to the purchase of NXP Semiconductors products by customer.

No offer to sell or license — Nothing in this document may be interpreted or construed as an offer to sell products that is open for acceptance or the grant, conveyance or implication of any license under any copyrights, patents or other industrial or intellectual property rights.

Export control — This document as well as the item(s) described herein may be subject to export control regulations. Export might require a prior authorization from competent authorities.

Quick reference data — The Quick reference data is an extract of the product data given in the Limiting values and Characteristics sections of this document, and as such is not complete, exhaustive or legally binding.

Translations — A non-English (translated) version of a document is for reference only. The English version shall prevail in case of any discrepancy between the translated and English versions.

10.4 Trademarks

Notice: All referenced brands, product names, service names and trademarks are the property of their respective owners.

I²C-bus — logo is a trademark of NXP B.V.

11. Contact information

For more information, please visit: <http://www.nxp.com>

For sales office addresses, please send an email to: salesaddresses@nxp.com

12. Contents

1	General description	1
2	Features and benefits	1
3	Quick reference data	2
4	Ordering information	3
5	Pinning information	4
5.1	Pinning	4
5.2	Pin description	6
6	Thermal characteristics	7
7	Characteristics	8
8	Package outline	15
9	Revision history	18
10	Legal information	19
10.1	Data sheet status	19
10.2	Definitions	19
10.3	Disclaimers	19
10.4	Trademarks	20
11	Contact information	20
12	Contents	21

Please be aware that important notices concerning this document and the product(s) described herein, have been included in section 'Legal information'.

© NXP B.V. 2013.

All rights reserved.

For more information, please visit: <http://www.nxp.com>

For sales office addresses, please send an email to: salesaddresses@nxp.com

Date of release: 27 September 2013

Document identifier: TDF8546_SDS