



Chipsmall Limited consists of a professional team with an average of over 10 year of expertise in the distribution of electronic components. Based in Hongkong, we have already established firm and mutual-benefit business relationships with customers from,Europe,America and south Asia,supplying obsolete and hard-to-find components to meet their specific needs.

With the principle of “Quality Parts,Customers Priority,Honest Operation,and Considerate Service”,our business mainly focus on the distribution of electronic components. Line cards we deal with include Microchip,ALPS,ROHM,Xilinx,Pulse,ON,Everlight and Freescale. Main products comprise IC,Modules,Potentiometer,IC Socket,Relay,Connector.Our parts cover such applications as commercial,industrial, and automotives areas.

We are looking forward to setting up business relationship with you and hope to provide you with the best service and solution. Let us make a better world for our industry!



Contact us

Tel: +86-755-8981 8866 Fax: +86-755-8427 6832

Email & Skype: info@chipsmall.com Web: www.chipsmall.com

Address: A1208, Overseas Decoration Building, #122 Zhenhua RD., Futian, Shenzhen, China





TEA19362T

GreenChip SMPS primary side control IC with fixed frequency operation

Rev. 1 — 9 August 2016

Product data sheet

1 General description

The TEA19362T is a member of the GreenChip family of controller ICs for switched mode power supplies. It is intended for flyback topologies to be used either standalone or together with smart charging controllers (like the TEA190x series) at the secondary side. It also offers improved compatibility with touch-screens. The built-in green functions provide high efficiency at all power levels.

The TEA19362T is compatible with smart charging applications that require fixed-frequency operation. Fixed-frequency operation minimizes Common-Mode Noise (CMN) and optimizes spectral purity towards the (mobile) touch screens. When used with a secondary-side controller IC, like the TEA190x series, it supports Constant Current (CC) mode down to 3 V output voltage.

At high power levels, the flyback can operate in Boundary Conduction Mode (BCM) depending on application components. For lowest CMN and highest spectral purity, the TEA19362T can be set to full Discontinuous Conduction Mode (DCM) operation. Switch-on, based on demagnetization sensing, enables steady operation at a constant frequency. In this way, a cleaner CMN spectrum is achieved.

At very low power levels, the controller uses burst mode to regulate the output power. A special optocoupler current reduction regulation has been integrated which reduces the average optocurrent in all modes to a minimum level. This reduction ensures high efficiency at low power and excellent no-load power performance. As the switching frequency in this mode equals the nominal frequency (f_{sw}) and the burst repetition rate is regulated to a fixed value, spectral purity is preserved and output ripple is limited. During the non-switching phase of the burst mode, the internal IC supply current is minimized for further efficiency optimization.

The TEA19362T includes a wide set of protections that are safe-restart protections. One of these protections is an accurate OverPower Protection (OPP). If the output is shorted, the system stops switching and restarts. The output power is then limited to a lower level.

The TEA19362T is manufactured in a high-voltage Silicon-On-Insulator (SOI) process. The SOI process combines the advantages of a low-voltage process (accuracy, high-speed protection, functions, and control). However, it also maintains the high-voltage capabilities (high-voltage start-up, low standby power, and brownin/brownout sensing at the input).

The TEA19362T enables low-cost, highly efficient and reliable supplies for power requirements up to 75 W using a minimum number of external components.



2 Features and benefits

2.1 General features

- SMPS controller IC supporting smart-charging applications and multiple-output-voltage applications
- Wide output range (5 V to 20 V in CV mode, 3 V to 20 V in CC mode, and 3 V to 6 V in direct charging mode)
- Fixed-frequency operation suited for mobile charger applications that require low CMN distortion and high spectral purity
- Housed in a small SO10 package
- Adaptive dual supply for highest efficiency over the entire output voltage range
- Integrated high-voltage start-up
- Continuous V_{CC} regulation during start-up and protection via the HV pin, allowing a minimum VCC capacitor value
- Reduced optocurrent enabling low no-load power (20 mW at 5 V output)
- Fast transient response from 0 to full load
- Minimal output voltage ripple in all operating modes
- Integrated soft start

2.2 Green features

Enables high efficiency operation over a wide power range via:

- Low supply current during normal operation (0.6 mA without load)
- Low supply current during non-switching state in burst mode (0.25 mA)
- Demagnetization switching for minimum switching losses

2.3 Protection features

All protections are safe-restart protections.

- Mains voltage compensated OverPower Protection (OPP)
- OverTemperature Protection (OTP)
- Integrated overpower time-out
- Integrated restart timer for system fault conditions
- Continuous mode protection using demagnetization detection
- Accurate OverVoltage Protection (OVP)
- General-purpose input for safe restart protection; for use with system OverTemperature Protection (OTP)
- Driver maximum on-time protection
- Brownin and brownout protection

3 Applications

- Battery chargers for smart phones and media tablets
- Battery chargers for mobile devices with touchpad display

4 Ordering information

Table 1. Ordering information

Type number	Package		Version
	Name	Description	
TEA19362T/1	SO10	plastic small outline package; 10 leads; body width 3.9 mm; body thickness 1.35 mm	SOT1437-1

5 Marking

Table 2. Marking codes

Type number	Marking code
TEA19362T/1	TEA19362T

6 Block diagram

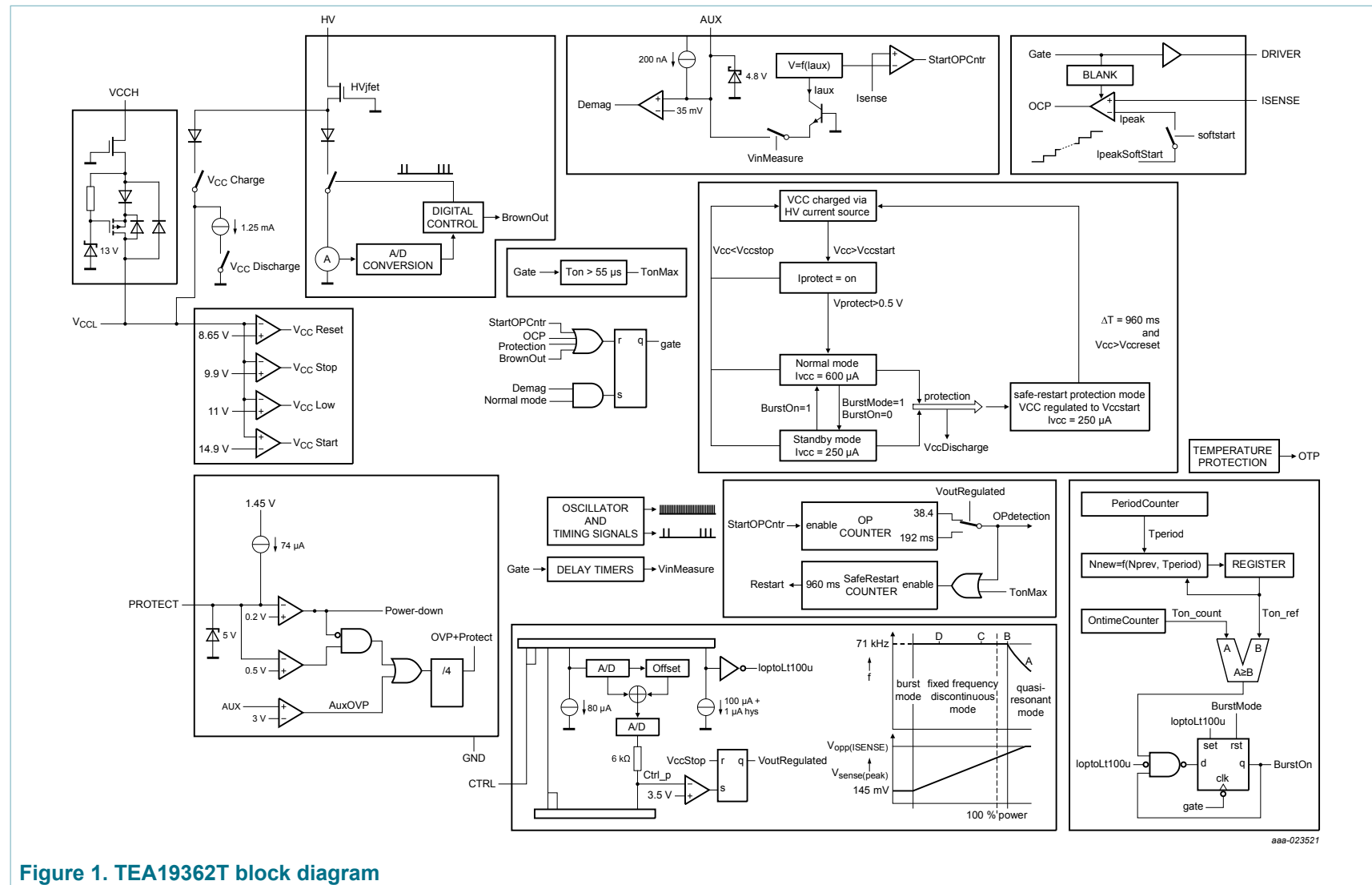

aaa-023521

Figure 1. TEA19362T block diagram

7 Pinning information

7.1 Pinning

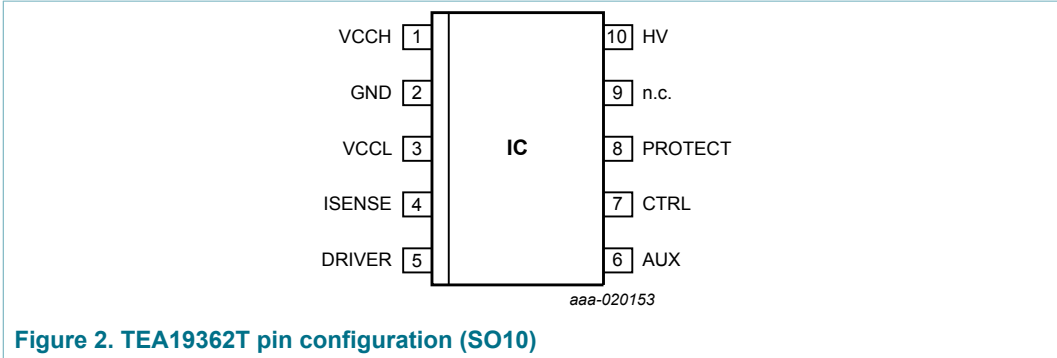

Figure 2. TEA19362T pin configuration (SO10)

7.2 Pin description

Table 3. Pin description

Symbol	Pin	Description
VCCH	1	higher supply voltage
GND	2	ground
VCCL	3	lower supply voltage
ISENSE	4	current sense input
DRIVER	5	gate driver output
AUX	6	auxiliary winding input for demagnetization timing, overpower correction, and OVP
CTRL	7	control input
PROTECT	8	general-purpose protection input; pin for power-down mode
n.c.	9	high-voltage safety spacer; not connected
HV	10	high-voltage start-up; brownin/brownout sensing

8 Functional description

8.1 Supply management

The chip is supplied by high-voltage mains via the HV pin during start-up and protection mode. When the system starts switching, the auxiliary windings take over the supply.

The IC has two supply pins, the VCCH and VCCL pins. The lower pin (VCCL) supplies the IC directly. The higher supply pin (VCCH) is connected to the VCCL pin via an internal voltage regulator. When used in an application, which supports multiple output voltages, a pair of auxiliary transformer windings can be used to supply the IC efficiently at all output levels. To supply the IC at higher output voltages, the winding with fewer turns can be connected to the VCCL pin. At the lower output voltages, the winding with more turns can supply the IC via the VCCH pin. The voltage capability of these pins is chosen such that applications with an output voltage range from 3 V to 20 V are supported optimally. When the voltage on the VCCL pin drops to below $V_{\text{integd}(VCCL)}$, the regulator between the VCCH and VCCL pins turns on.

All internal reference voltages are derived from a temperature compensated on-chip band gap circuit. Internal reference currents are derived from a trimmed and temperature-compensated current reference circuit.

8.2 Start-up and UnderVoltage LockOut (UVLO)

Initially, the capacitor on the VCCL pin is charged from the high-voltage mains using the HV pin. The voltage on the VCCH pin follows (via an internal diode) the voltage on VCCL pin. In this way, the capacitor on the VCCH pin is charged. As long as V_{CC} (the voltage on pin VCCL) is below V_{startup} , the IC current consumption is minimized. When V_{CC} reaches the V_{startup} level, the control logic activates the internal circuitry. The IC waits for the PROTECT pin to reach $V_{\text{det}(\text{PROTECT})} + V_{\text{det}(\text{hys})\text{PROTECT}}$ and the mains voltage to increase to above the brownin level. Meanwhile, the internal power-control signal (which depends on the current at the CTRL pin) also increases to its maximum value. When all these conditions are met, the system starts switching with soft start. In a typical application, the auxiliary winding of the transformer takes over the supply.

During the start-up period, the VCC pin is continuously regulated to the V_{startup} level using the HV charge current. The pin is regulated until the output voltage is at its regulation level, which is detected via the CTRL pin. In this way, the VCC capacitor value can be limited. Due to the limited current capability from the HV pin mains voltage dependent, the voltage on pin VCC can still drop slightly during the start-up period.

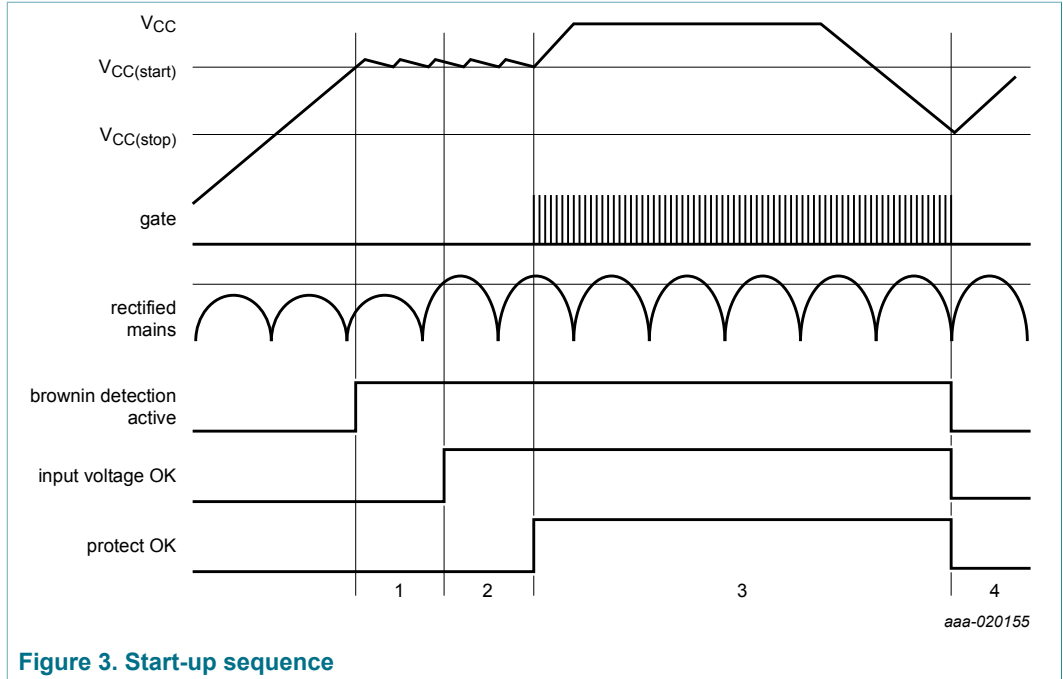

8.3 Modes of operation

The TEA19362T operates primarily in fixed frequency DCM mode. At low powers, it enters burst mode. At high powers, it can operate in Quasi-Resonance (QR) mode (see [Figure 4](#)). The auxiliary winding of the flyback transformer provides demagnetization information.

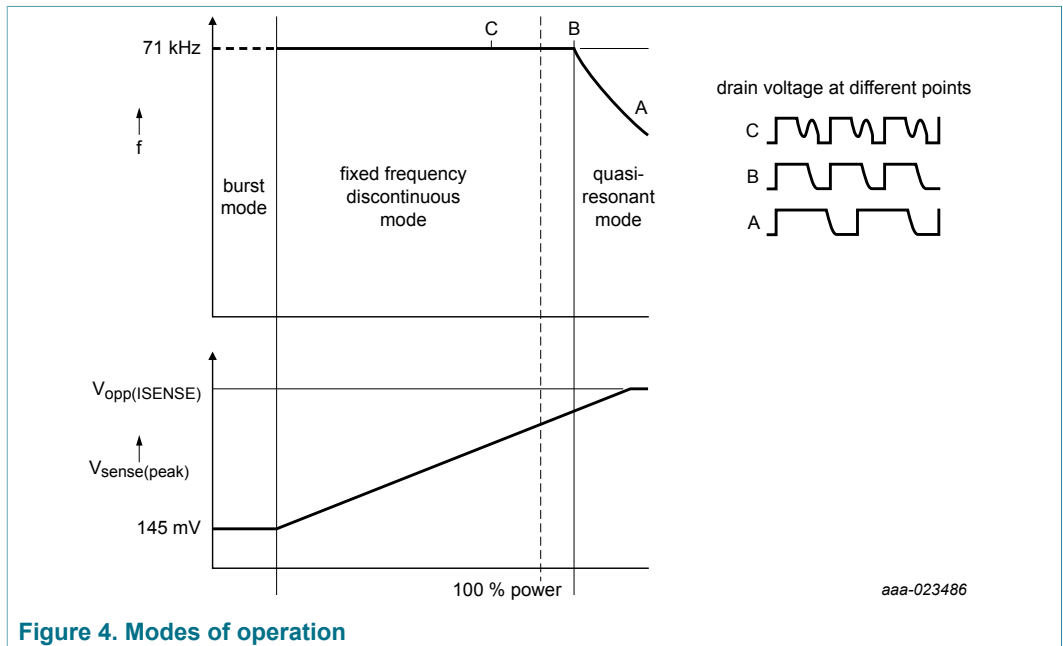

Fixed-frequency DCM mode is the primary mode of operation. It is based on an accurate oscillator, which sets the nominal switching period. When the oscillator time-period has completed and transformer demagnetization is detected at the AUX pin, a new switching cycle is started.

When the drain voltage is in the bottom half of its ringing cycle, but not necessarily at the deepest point in the valley, the switch is turned on. It allows a large enough window of opportunity where switch-on is allowed. So, valley hopping due to small variations in input or output is minimized. The switching frequency remains constant as a result. In DCM operation, especially at higher mains, the ringing amplitude of the later valleys is reduced significantly because of damping. So, the penalty of not switching on at the deepest point in the valley is negligible.

If dictated by the application design choices, the TEA19362T can operate in QR mode as well. In QR-mode, the efficiency of the converter is highest due to optimum use of the transformer.

At low power, the converter enters the burst mode. In burst mode, the switching frequency within each burst is the same as in the DCM fixed frequency mode.

The application components can be chosen such that from minimum to maximum power the converter operates at the same frequency, while it remains outside the QR region. Operating at one frequency allows a well-defined CMN spectrum. A clean CMN spectrum is essential for achieving the lowest interference between charger and the cell phone touch screen controller.

8.4 Mains voltage measuring

In a typical application, the mains input voltage is measured using the HV pin.

The rectified mains voltage is measured every 1 ms by pulling down the HV pin to ground and measuring its current. This current then reflects the input voltage.

The system determines if the mains voltage exceeds the brownin level.

When the mains exceeds the brownin level, the system is allowed to start switching.

If the mains voltage is continuously below the brownout level for at least 30 ms, a brownout is detected and the system immediately stops switching. This period is required to avoid that the system stops switching during a short mains interruption.

If the measured mains level exceeds the brownin/brownout threshold, subsequent measuring of the mains input voltage is stopped for 6.7 ms to improve efficiency. In burst mode, this waiting period is increased to 101 ms.

8.5 Auxiliary winding

To supply the control IC efficiently, the VCCH and VCCL pins are connected to auxiliary windings via a diode and a capacitor.

To detect demagnetization and input and output voltage, one of the auxiliary windings is connected to the AUX pin via a resistive divider (see [Figure 19](#) and [Figure 20](#)). Each switching cycle is divided in sections. During each section, the system knows if the voltage or current out of the AUX pin reflects the demagnetization, valley, input voltage, or output voltage (see [Figure 5](#)).

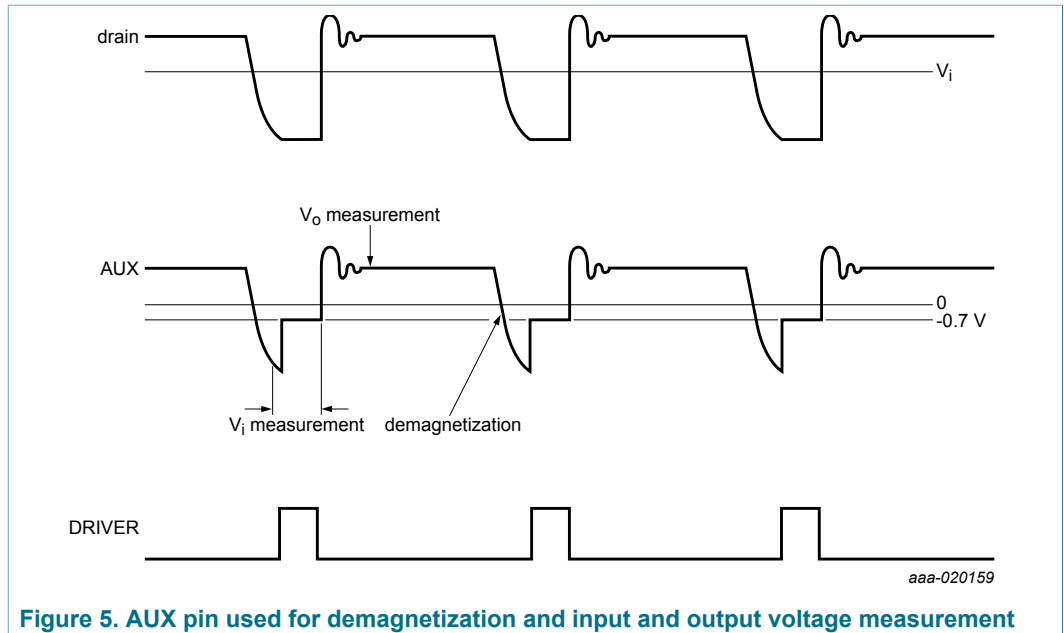

Figure 5. AUX pin used for demagnetization and input and output voltage measurement

When the external MOSFET is switched on, the voltage at the auxiliary windings reflects the input voltage. The AUX pin is clamped to -0.7 V . The output current is a measure of the input voltage. This current value is internally used to set the overpower limit on $V_{\text{sense(ipk)}}$. The demagnetization and output voltages are measured as a voltage on the AUX pin. In this way, the input voltage measurement and OVP can be adjusted independently.

8.6 Protections

If a protection is triggered, the controller stops switching. To avoid false triggering, some protections have a built-in delay.

Table 4. Protections

Protection	Delay	Action	V _{CC} regulated
AUX open	no	wait until AUX is connected	no
brownout	29 ms	wait until $V_{\text{mains}} > V_{\text{bi}}$	yes
maximum on-time	no	safe restart	yes
OTP internal	4.5 μs	safe restart	yes
OTP via the PROTECT pin	2 ms to 4 ms	safe restart	yes
OVP via the AUX pin	4 driver pulses ^[1]	safe restart	yes
overpower time-out	38.4 ms to 192 ms	safe restart	yes
overpower + UVLO	no	safe restart	yes
overcurrent protection	blanking time	cycle-by-cycle	no
UVLO	no	Wait until $V_{\text{VCCCL}} > V_{\text{startup}}$	yes

[1] When the voltage on the PROTECT pin is below $V_{\text{det(PROTECT)}}$, the clock of the delay counter is changed from the driver pulse to 1 ms internal pulse.

When the system stops switching, the VCCH and VCCL pins are not supplied via the auxiliary winding anymore. Depending on the protection triggered, V_{VCCL} is either regulated to the $V_{startUp}$ level via the HV pin or dropped down until the UVLO protection triggered (see Table 4).

8.6.1 OverPower Protection (OPP)

The overpower protection function is used to realize a maximum output power which is nearly constant over the full input mains.

For applications intended to operate fully in DCM mode, a constant overpower protection level can be set by using the flat portion of the OPP curve (see Figure 6). On the other hand, applications designed to operate in QR mode at maximum power require the OPP level to be compensated for mains. They can be set to use the variable part of the OPP curve.

The resistors connected to the AUX pin set the I_{AUX} . They determine which part of the OPP curve is used by the application.

The overpower compensation circuit measures the input voltage via the AUX pin. The circuit outputs an overpower reference voltage that depends on this input voltage. If the measured voltage at the ISENSE pin exceeds the overpower reference voltage ($V_{opp(ISENSE)}$), the DRIVER output is pulled low (the primary stroke is cut short). The overpower timer starts. In this way, the system limits the power to the maximum rated value on a cycle-by-cycle base. If the overpower situation persists continuously for 192 ms, an overpower time-out is triggered. Figure 6 shows the overpower protection curve.

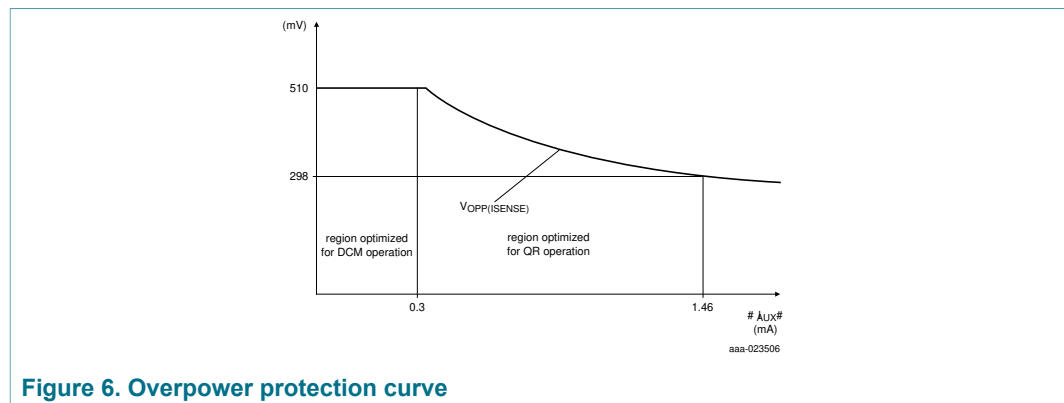

Figure 6. Overpower protection curve

During system start-up, the maximum time-out period is lowered to 38.4 ms. When the output voltage is within its regulation level, the maximum time-out period returns to 192 ms, limiting the output power to a minimum at a shorted output. Shortening the overpower timer ensures that the input power of the system is limited to < 5 W at a shorted output.

If the load requires more power than allowed by the OPP limit, the output voltage drops because of the limited output power. As a result, the V_{CC} voltage also drops and UVLO can be triggered. To retain the same response in an overpower situation (whether UVLO is triggered or not), the system enters the overpower protection mode when overpower and UVLO are detected. The system entering the protection mode does not depend on the value of the OP counter.

8.6.2 OverVoltage Protection (OVP; pins AUX and VCCL)

An accurate output OVP is implemented by measuring the voltage at the AUX pin during the secondary stroke. As the auxiliary winding voltage is a well-defined replica of the output voltage, the external resistor divider ratio $R_{AUX2} / (R_{AUX1} + R_{AUX2})$ can adjust the OVP level.

An accurate OVP circuit is also connected to the VCCL pin. It measures if the VCCL pin voltage exceeds the level $V_{ovp(VCCL)}$ at the end of primary stroke.

An internal counter of four gate pulses prevents false OVP detection which can occur during ESD or lightning events.

8.6.3 Protection input (PROTECT pin)

The PROTECT pin is a general-purpose input pin. It can be used to trigger a safe restart. When the voltage on the PROTECT pin is pulled below $V_{det(PROTECT)}$ (0.5 V), the converter is stopped.

The PROTECT pin can be used to create an OTP function. To create the OTP function, a Negative Temperature Coefficient (NTC) resistor must be connected to this pin. When the voltage on the PROTECT pin drops to below 0.5 V, overtemperature is detected. The PROTECT current flowing through the external NTC resistor creates the voltage. The PROTECT voltage is clamped to maximum 1.4 V. At room temperature, the resistance value of the NTC resistor is much higher than at high temperatures. Because of the clamp, the current out of the PROTECT pin is 1.4 V divided by the resistance, which is much lower than 74 μ A.

A filter capacitor can be connected to the PROTECT pin.

To avoid false triggering, an internal filter of 2 ms to 4 ms is applied.

8.6.4 OverTemperature Protection (OTP)

If the junction temperature exceeds the thermal temperature shutdown limit, an integrated OTP feature ensures that the IC stops switching. OTP is a safe restart protection.

A built-in hysteresis ensures that the internal temperature must drop 10 °C degrees before the IC restarts.

8.6.5 Maximum on-time

The controller limits the on-time of the external MOSFET to 55 μ s. When the on-time is longer, the IC stops switching and enters safe restart mode.

8.6.6 Safe restart

If a protection is triggered and the system enters the safe restart mode, the system restarts after a delay time ($t_{d(restart)}$). An internal current source ($I_{CC(dch)}$) discharges the voltage on pin VCCL. The discharge allows the conditions at a restart to be similar to a normal start-up. Because the system is not switching, the VCCL and VCCH pins are supplied from the mains via the HV pin.

After the restart delay time ($t_{d(\text{restart})}$), the control IC measures the mains voltage. If the mains voltage exceeds the brownin level, the control IC activates the PROTECT pin current source and the internal voltage sources connected to the CTRL pin. When the voltages on these pins reach a minimum level, the soft start capacitor on the ISENSE pin is charged and the system starts switching again.

The V_{CC} is continuously regulated to the V_{startup} level until the output voltage is within the regulation level again.

8.7 Optobias regulation (CTRL pin)

In a typical application, the output voltage (or current) is sensed on the secondary side (by a TL431 or a controller such as TEA190x). The feedback signal is passed to the primary side via an optocoupler. The optocoupler sends the current information to the CTRL pin of the TEA19362T (see Figure 19 and Figure 20).

The TEA19362T applies a relatively fixed voltage at the CTRL pin (the input impedance of the CTRL pin is $R_{\text{int(CTRL)}}$). It senses the current through the optocoupler. The TEA19362T compares the current with an internal regulation level $I_{\text{IO(reg)CTRL}}$ ($80 \mu\text{A}$). The difference is integrated with a slow time constant (in ms). It is added to the control signal that sets the output power. If the optocurrent (at CTRL pin) exceeds the regulation level ($I_{\text{IO(reg)CTRL}}$), the control signal reduces in this way, which leads to an output power decrease and vice versa. The optocurrent (at the CTRL pin) slowly regulates towards the regulation level ($I_{\text{IO(reg)CTRL}}$). The result is a constant optocurrent during stable operation at all output power levels.

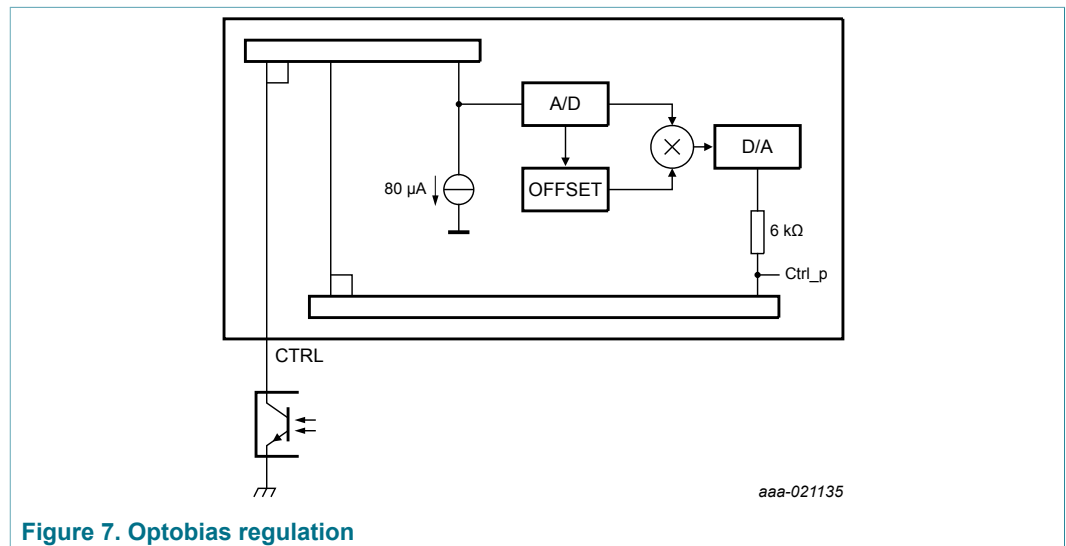

Figure 7 shows the slow optocurrent regulation loop.

In addition to the slow optocurrent regulation loop described above, the CTRL current directly contributes to the internal power control by creating a voltage drop across a $6 \text{ k}\Omega$ resistor (See Figure 7). It determines the transient behavior of the power regulation loop, which remains similar to ICs, like the TEA1836. The control loop responds to load or line variations through this direct optocurrent contribution, whereas the slow offset loop simply sets the steady state operation point.

The advantages of this type of regulation are:

- The optocoupler collector parasitics do not influence the loop. So, more freedom in tuning the loop characteristics is ensured.
- Unlike the traditional situation where the optocoupler current becomes much higher at lower output power, it retains the same low value in steady state at all powers.

Since the optocurrent is only 80 μA even at low powers, a load step to a very high load can result in a maximum decrease of the optocurrent by this amount only. It limits the possible power increase. To counter this possibility, the offset loop enters a fast regulation mode when a significant optocurrent decrease is detected (to about 20 μA under the regulation level). The fast regulation mode ensures a quick output power increase.

8.8 Burst mode operation

When the output power drops to below the minimum level the system can supply while operating at the minimum power setting (i.e. $V_{\text{sense(peak)}}$ is at its minimum), it can no longer reduce the optocurrent level to the regulation level $I_{\text{IO(reg)CTRL}} (= 80 \mu\text{A})$. In this situation, the optocurrent increases to exceed the level of the burst threshold ($I_{\text{th(burst)CTRL}}$) and the burst mode is entered. Switching is paused and a burst-off period commences. Consequently, the optocurrent decreases. When it drops to below the $I_{\text{th(burst)CTRL}}$, a new burst of switching cycles is started (see [Figure 8](#) and [Figure 9](#)).

[Figure 8](#) shows that the switching frequency within a burst remains the same as in the DCM mode. The target burst repetition period is t_{burst} .

The requested output power determines the number of pulses at each burst period. At higher output power, the number of switching pulses increases. At low load, it decreases. This burst mode regulation allows low-load operation without compromising on spectral purity, while keeping the output ripple limited. In addition, the optocoupler current is maintained at a very low level during low-load and standby operation. The result is a very low standby power consumption.

To ensure good efficiency at very low load, the minimum number of switching cycles is set to 1. When the minimum number of pulses is reached, the burst repetition period cannot be reduced further. As the power decreases, the repetition rate of the single-pulse bursts decreases as well to a very low value. To improve further, the no-load input power and efficiency at low load, the current consumption of the IC is lowered to 250 μA during the non-switching period in the burst mode.

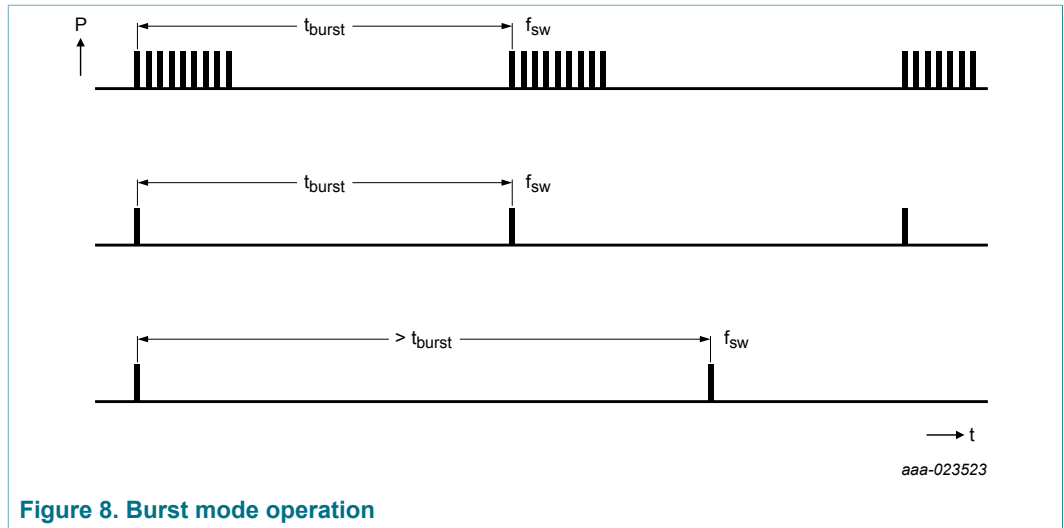

Figure 8. Burst mode operation

To achieve a good transient response at an increased output load, the system starts switching immediately when I_{CTRL} increases to exceed $I_{th(burst)}$. It keeps switching until the optocurrent exceeds the level of $I_{th(burst)CTRL}$. On the other hand, to achieve a good transient response at a decreased output load, the system stops switching immediately when the optocurrent exceeds the level of $I_{stop(burst)CTRL}$ at a decreased output load. In both situations, the calculated number of switching pulses by the internal digital circuit is overruled for the present burst cycle.

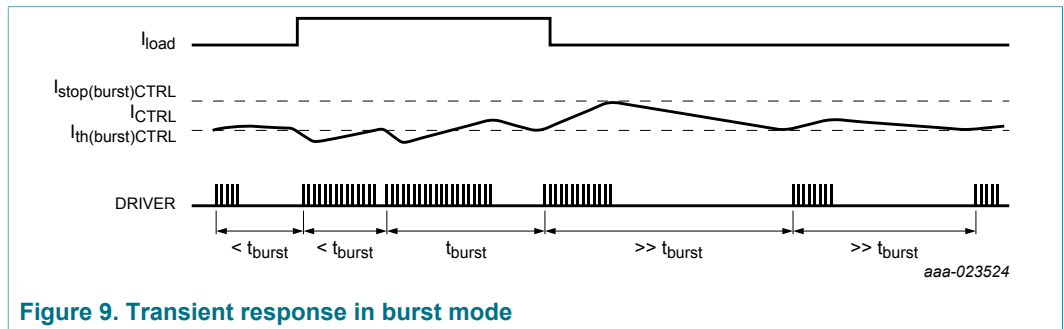

Figure 9. Transient response in burst mode

Even though the burst-mode regulates towards a target repetition frequency, the actual repetition rate is lower than the target because of the discrete number of switching cycles. Increasing or decreasing the number of pulses results in a step change in the burst repetition frequency.

Before reducing the number of pulses in the next burst, it is ensured that the resulting repetition rate does not exceed the target frequency. Hence, at any moment in burst-mode operation, the actual burst repetition rate is within a band under the target frequency. If the number of burst pulses decreases, the effect of adding a pulse increases and the band becomes wider (see [Figure 10](#)).

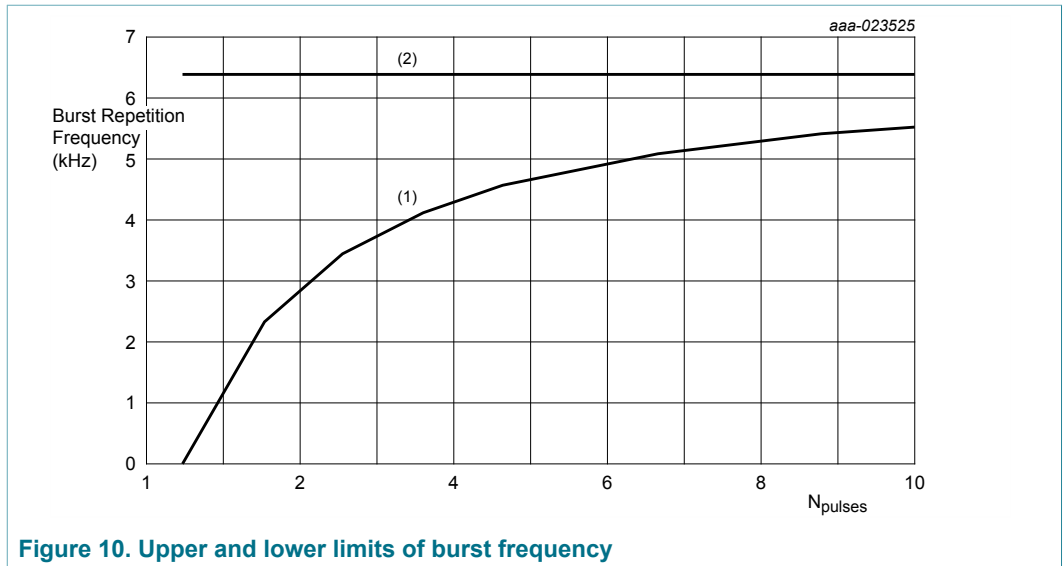

Figure 10. Upper and lower limits of burst frequency

When the burst on time is 1.5 times longer than the target period (t_{burst}), the system switches to normal mode again.

8.9 Soft start-up (ISENSE pin)

To prevent audible noise during start-up or a restart condition, an integrated soft start feature is implemented. When the converter starts switching, the primary peak current slowly increases to the regulated level with 15 steps.

The soft start time constant is 3.6 ms, set by an internal time.

8.10 Driver (DRIVER pin)

The driver circuit to the gate of the power MOSFET has a current sourcing capability of 300 mA and a current sink capability of 750 mA. These capabilities allow a fast turn-on and turn-off of the power MOSFET for efficient operation.

The maximum driver output is limited to 10.5 V. The DRIVER output pin can be connected to the gate of a MOSFET directly or via a resistor.

9 Limiting values

Table 5. Limiting values

In accordance with the Absolute Maximum Rating System (IEC 60134).

Symbol	Parameter	Conditions	Min	Max	Unit
Voltages					
$V_{IO(HV)}$	input/output voltage on pin HV		-0.4	+700	V
V_{VCCH}	voltage on pin VCCH	dual supply voltage	-0.4	+120	V
V_{VCCL}	voltage on pin VCCL	dual supply voltage	-0.4	+50	V
$V_{IO(CTRL)}$	input/output voltage on pin CTRL		-0.4	+12	V
$V_{I(ISENSE)}$	input voltage on pin ISENSE		-0.4	+12	V
$V_{IO(PROTECT)}$	input/output voltage on pin PROTECT	current limited	-0.4	+5	V
$V_{IO(AUX)}$	input/output voltage on pin AUX	current limited	-5	+5	V
Currents					
$I_{IO(AUX)}$	input/output current on pin AUX		-1.5	+1	mA
$I_{IO(HV)}$	input/output current on pin HV		-1	+5	mA
$I_{IO(CTRL)}$	input/output current on pin CTRL		-3	0	mA
$I_{IO(PROTECT)}$	input/output current on pin PROTECT		-1	+1	mA
General					
P_{tot}	total power dissipation	$T_{amb} < 75\text{ °C}$	-	1	W
T_{stg}	storage temperature		-55	+150	°C
T_j	junction temperature		-40	+150	°C

Symbol	Parameter	Conditions	Min	Max	Unit
ElectroStatic Discharge (ESD)					
V_{ESD}	electrostatic discharge voltage	class 1			
		human body model ^[1]			
		HV and VCCH pins	-	1000	V
		all other pins	-	2000	V
		charged device model ^[2]	-	500	V

[1] According to JEDEC JS-001.

[2] According to JEDEC JESD22-C101 and ANSI S5.3.1.

10 Recommended operating conditions

Table 6. Recommended operating conditions

Symbol	Parameter	Conditions	Min	Max	Unit
Voltages					
$V_{IO(HV)}$	input/output voltage on pin HV		0	380	V
V_{VCCH}	voltage on pin VCCH	dual supply voltage	0	120	V
V_{VCCL}	voltage on pin VCCL	dual supply voltage; continuous	-	45	V
$V_{IO(CTRL)}$	input/output voltage on pin CTRL		0	5	V
$V_{I(ISENSE)}$	input voltage on pin ISENSE		0	5	V
$V_{IO(PROTECT)}$	input/output voltage on pin PROTECT	current limited	0	2	V
$V_{IO(AUX)}$	input/output voltage on pin AUX	current limited	-5	+5	V
Currents					
$I_{IO(AUX)}$	input/output current on pin AUX		-1	+1	mA
$I_{IO(HV)}$	input/output current on pin HV		0	2	mA
$I_{IO(CTRL)}$	input/output current on pin CTRL		-1	0	mA
$I_{IO(PROTECT)}$	input/output current on pin PROTECT		-1	+1	mA
General					
T_j	junction temperature		-25	+125	°C

11 Thermal characteristics

Table 7. Thermal characteristics

Symbol	Parameter	Conditions	Typ	Unit
$R_{th(j-a)}$	thermal resistance from junction to ambient	JEDEC test board	148	K/W
$R_{th(j-c)}$	thermal resistance from junction to case	JEDEC test board	86	K/W

12 Characteristics

Table 8. Characteristics

Limits are production tested at 25 °C and are guaranteed by statistical characterization in the temperature operating range. $V_{CC} = 20$ V; all voltages are measured with respect to ground (pin 2); currents are positive when flowing into the IC; unless otherwise specified.

Symbol	Parameter	Conditions	Min	Typ	Max	Unit
Start-up current source (HV pin)						
$I_{startup(HV)}$	start-up current on pin HV	$V_{HV} > 10$ V	0.8	1.15	1.5	mA
		$V_{CC} > V_{startup}$; HV not sampling	-	-	1	μ A
V_{clamp}	clamp voltage	$I_{HV} < 2$ mA	-	-	680	V
Supply voltage management (VCCL pin)						
$V_{startup}$	start-up voltage		13.4	14.9	16.4	V
$V_{intregd(VCCL)}$	internal regulated voltage on pin VCCL	via VCCH; $I_{CC} = 0.5$ mA	12.1	12.5	12.9	V
$V_{restart}$	restart voltage	burst mode	9.9	11	12.1	V
$V_{th(UVLO)}$	undervoltage lockout threshold voltage		9.0	9.9	10.8	V
V_{rst}	reset voltage		7.75	8.65	9.55	V
$I_{CC(startup)}$	start-up supply current	$V_{HV} = 0$ V	-	40	-	μ A
		$V_{HV} > 10$ V	-1.45	-1.1	-0.75	mA
$I_{CC(oper)}$	operating supply current	driver unloaded; excluding optocurrent	-	600	-	μ A
$I_{CC(burst)}$	burst mode supply current	non-switching; excluding optocurrent	-	250	-	μ A
$I_{CC(prot)}$	protection supply current		-	250	-	μ A
$I_{CC(dch)}$	discharge supply current	safe restart protection; $V_{CC} > V_{startup}$	1.45	1.88	2.25	mA
Mains detect (HV pin)						
$t_{p(HV)}$	pulse duration on pin HV	measuring mains voltage	18	20	22	μ s
$f_{meas(HV)}$	measurement frequency on pin HV	measuring mains voltage	0.93	1.04	1.15	kHz

GreenChip SMPS primary side control IC with fixed frequency operation

Symbol	Parameter	Conditions	Min	Typ	Max	Unit
$t_{d(norm)HV}$	normal mode delay time on pin HV	measuring mains voltage	6.0	6.7	7.4	ms
$t_{d(burst)HV}$	burst mode delay time on pin HV	measuring mains voltage	90	101	112	ms
$I_{bo(HV)}$	brownout current on pin HV		552	587	622	μA
$I_{bi(HV)}$	brownin current on pin HV		623	663	703	μA
$I_{bo(hys)HV}$	hysteresis of brownout current on pin HV		-	76	-	μA
$I_{clamp(HV)}$	clamp current on pin HV	during measurement time	-	-	1.7	mA
$V_{meas(HV)}$	measurement voltage on pin HV		-	2.9	-	V
$t_{d(det)bo}$	brownout detection delay time		-	29	-	ms
Peak current control (pin CTRL)						
$V_{IO(CTRL)}$	input/output voltage on pin CTRL		-	2.7	-	V
$R_{int(CTRL)}$	internal resistance on pin CTRL		-	1.7	-	k Ω
$I_{clamp(CTRL)}$	clamp current on pin CTRL		-580	-500	-420	μA
Burst mode (pin CTRL)						
$I_{th(burst)CTRL}$	burst mode threshold current on pin CTRL		-125	-110	-95	μA
$I_{stop(burst)CTRL}$	burst mode stop current on pin CTRL		-230	-200	-170	μA
T_{burst}	burst mode period		-	155	-	μs
Oscillator						
f_{sw}	switching frequency		68	71	74	kHz
Current sense (pin ISENSE)						
$V_{sense(peak)}$	peak sense voltage	output overpower		$V_{opp(ISENSE)}$		mV
		burst mode	130	145	160	mV
$t_{PD(sense)}$	sense propagation delay	from the ISENSE pin reaching $V_{sense(max)}$ to driver off; V_{ISENSE} pulse-stepping 100 mV around $V_{sense(max)}$	-	120	-	ns
t_{leb}	leading edge blanking time		275	325	375	ns
Soft start (pin ISENSE)						
$t_{start(soft)}$	soft start time		3.2	3.6	4.0	ms

GreenChip SMPS primary side control IC with fixed frequency operation

Symbol	Parameter	Conditions	Min	Typ	Max	Unit
Demagnetization control (pin AUX)						
$V_{\text{det(demag)}}$	demagnetization detection voltage		20	40	60	mV
$I_{\text{prot(AUX)}}$	protection current on pin AUX		-	-200	-	nA
$t_{\text{blank(det)demag}}$	demagnetization detection blanking time		1.9	2.3	2.7	μs
$V_{\text{clamp(AUX)}}$	clamp voltage on pin AUX	$I_{\text{AUX}} = 1 \text{ mA}$	4.4	4.8	5.2	V
$t_{\text{sup(xfmr_ring)}}$	transformer ringing suppression time		2.0	2.4	2.8	μs
Maximum on-time (pin DRIVER)						
$t_{\text{on(max)}}$	maximum on-time		45	55	65	μs
Driver (pin DRIVER)						
$I_{\text{source(DRIVER)}}$	source current on pin DRIVER	$V_{\text{DRIVER}} = 2 \text{ V}$	-	-0.3	-	A
$I_{\text{sink(DRIVER)}}$	sink current on pin DRIVER	$V_{\text{DRIVER}} = 2 \text{ V}$	-	0.3	-	A
		$V_{\text{DRIVER}} = 10 \text{ V}$	-	0.75	-	A
$V_{\text{O(DRIVER)max}}$	maximum output voltage on pin DRIVER		9	10.5	12	V
Overpower protection (pin ISENSE and pin AUX)						
$V_{\text{clamp(AUX)}}$	clamp voltage on pin AUX	primary stroke; $I_{\text{AUX}} = -0.3 \text{ mA}$	-0.8	-0.7	-0.6	V
$t_{\text{d(clamp)AUX}}$	clamp delay time on pin AUX	after falling edge of pin DRIVER	1.9	2.3	2.7	μs
$V_{\text{opp(ISENSE)}}$	overpower protection voltage on pin ISENSE	counter trigger level				
		$I_{\text{AUX}} = -0.3 \text{ mA}$	460	510	560	mV
		$I_{\text{AUX}} = -1.46 \text{ mA}$	265	295	325	mV
$t_{\text{d(opp)}}$	overpower protection delay time	start-up mode; $I_{\text{CTRL}} < 100 \mu\text{A}$	34.5	38.4	42.3	ms
		normal mode	172	192	212	ms
$t_{\text{d(restart)}}$	restart delay time		860	960	1060	ms
External protection (pin PROTECT)						
$V_{\text{det(PROTECT)}}$	detection voltage on pin PROTECT		0.47	0.50	0.53	V
$V_{\text{det(hys)PROTECT}}$	detection voltage hysteresis on pin PROTECT		-	50	-	mV
$I_{\text{O(PROTECT)}}$	output current on pin PROTECT	normal mode	-79	-74	-69	μA
$V_{\text{clamp(PROTECT)}}$	clamp voltage on pin PROTECT		1.2	1.4	1.6	V

Symbol	Parameter	Conditions	Min	Typ	Max	Unit
Overvoltage protection (pin AUX)						
$V_{ovp(AUX)}$	overvoltage protection voltage on pin AUX		2.88	3.00	3.12	V
$V_{ovp(VCCL)}$	overvoltage protection voltage on pin VCCL		46.5	48	49.5	V
$t_{det(ovp)}$	overvoltage protection detection time	in the secondary stroke	2.0	2.4	2.8	μ s
Temperature protection						
$T_{pl(IC)}$	IC protection level temperature		130	140	150	$^{\circ}$ C
$T_{pl(IC)hys}$	hysteresis of IC protection level temperature		-	10	-	$^{\circ}$ C

12.1 Typical temperature performance characteristics

12.1.1 Start-up voltage

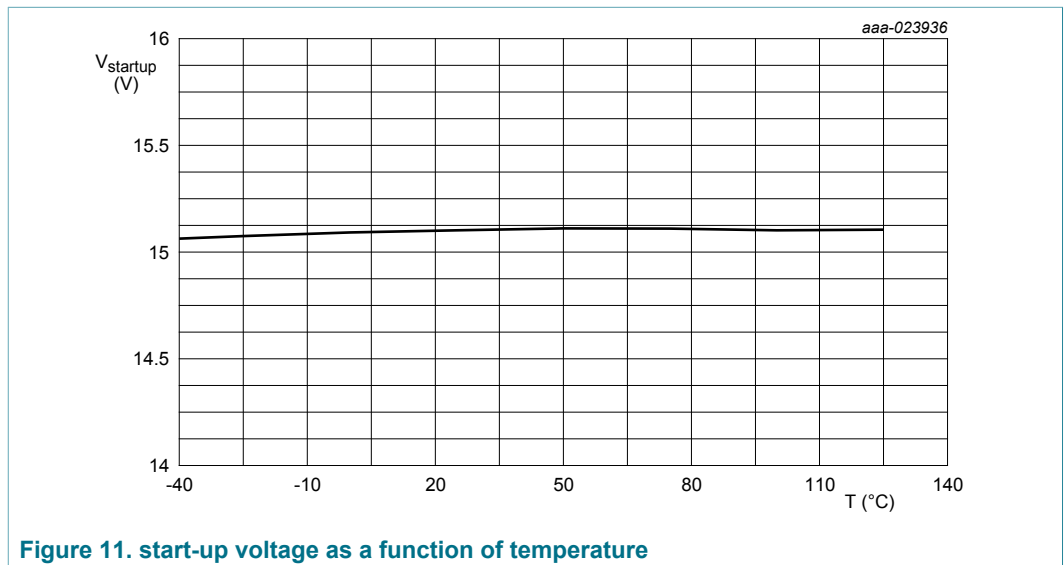

Figure 11. start-up voltage as a function of temperature

12.1.2 Undervoltage lockout threshold voltage

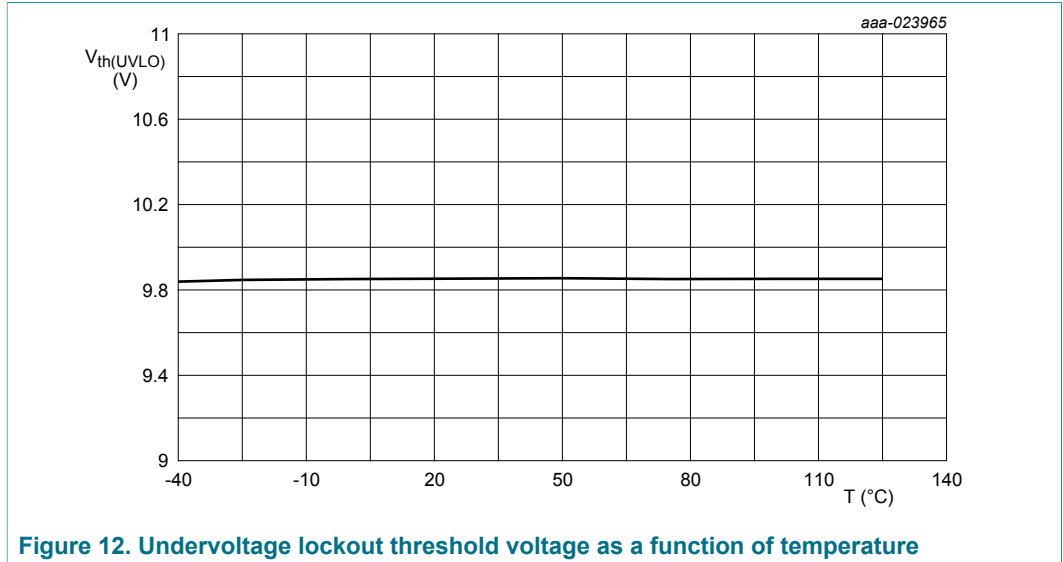

Figure 12. Undervoltage lockout threshold voltage as a function of temperature

12.1.3 Detection voltage (pin PROTECT)

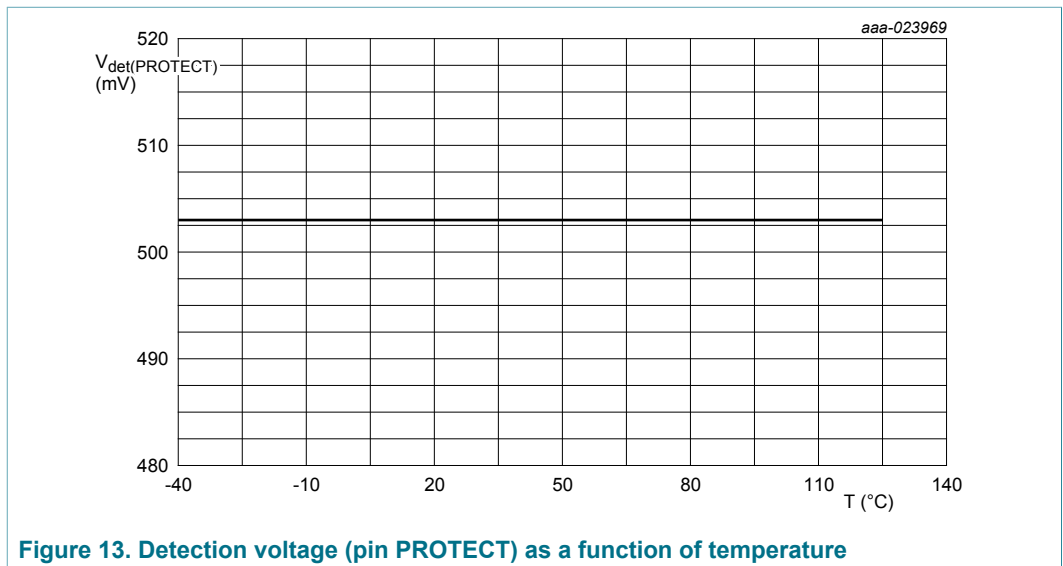
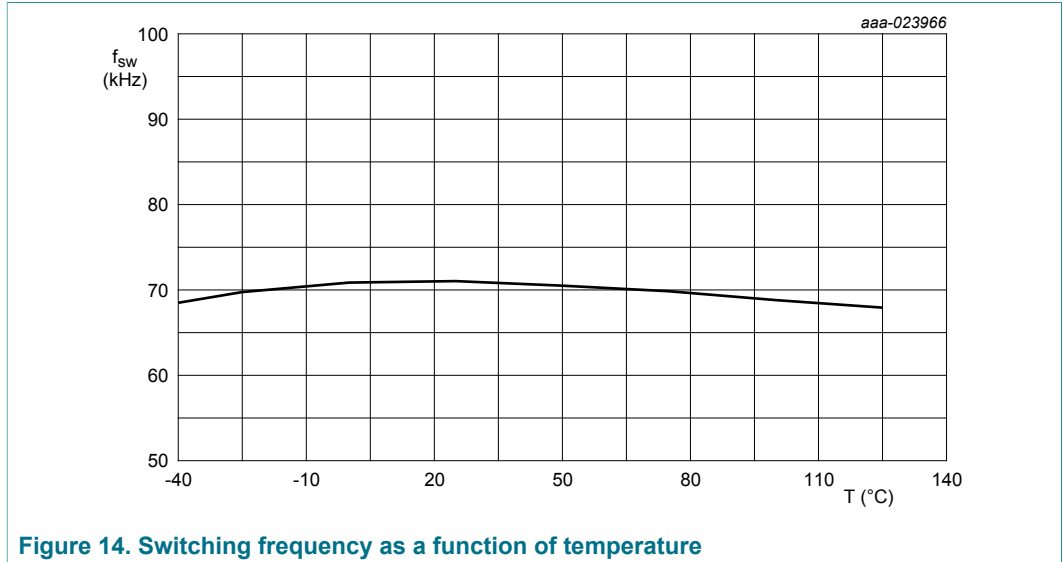
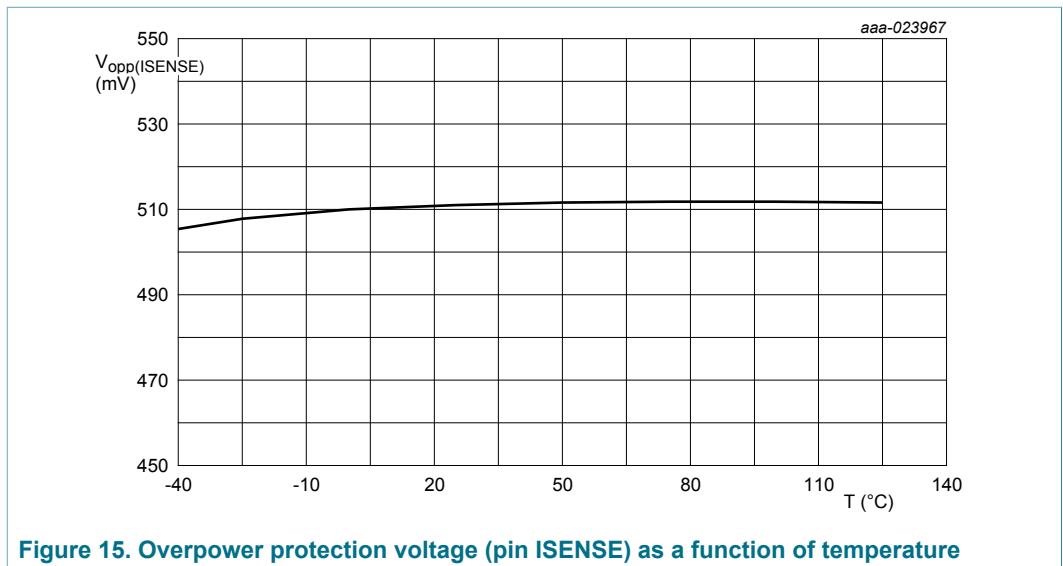

Figure 13. Detection voltage (pin PROTECT) as a function of temperature

12.1.4 Switching frequency



12.1.5 Overpower protection voltage (pin ISENSE)



12.1.6 Overpower protection (at $I_{AUX} = 1.46 \text{ mA}$)

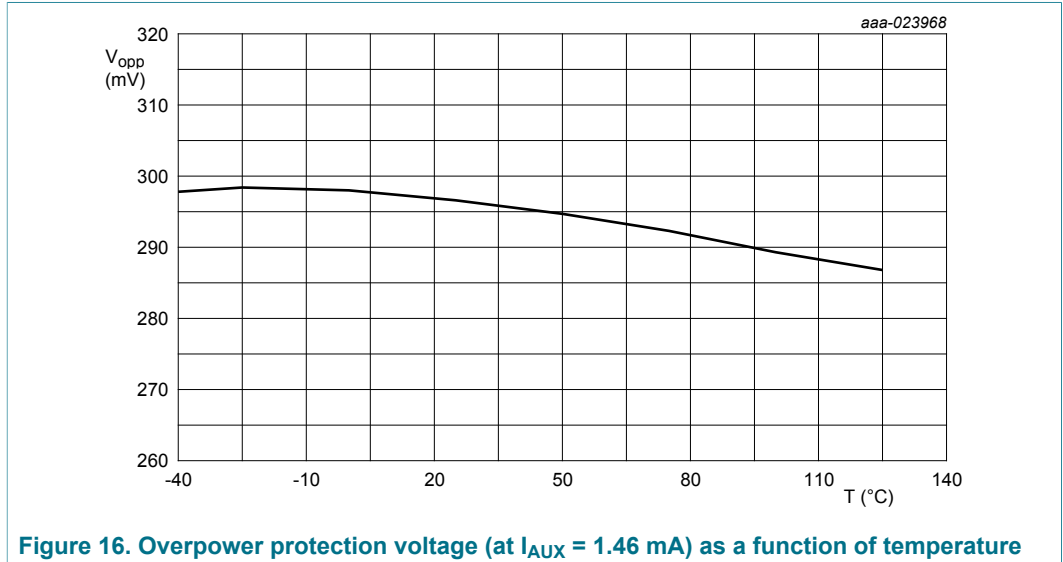

12.1.7 Output current (pin PROTECT)

