



Chipsmall Limited consists of a professional team with an average of over 10 year of expertise in the distribution of electronic components. Based in Hongkong, we have already established firm and mutual-benefit business relationships with customers from,Europe,America and south Asia,supplying obsolete and hard-to-find components to meet their specific needs.

With the principle of "Quality Parts,Customers Priority,Honest Operation,and Considerate Service",our business mainly focus on the distribution of electronic components. Line cards we deal with include Microchip,ALPS,ROHM,Xilinx,Pulse,ON,Everlight and Freescale. Main products comprise IC,Modules,Potentiometer,IC Socket,Relay,Connector.Our parts cover such applications as commercial,industrial, and automotives areas.

We are looking forward to setting up business relationship with you and hope to provide you with the best service and solution. Let us make a better world for our industry!



Contact us

Tel: +86-755-8981 8866 Fax: +86-755-8427 6832

Email & Skype: info@chipsmall.com Web: www.chipsmall.com

Address: A1208, Overseas Decoration Building, #122 Zhenhua RD., Futian, Shenzhen, China



DATA SHEET



TEA6848H

New In Car Entertainment car radio tuner IC with Precision Adjacent Channel Suppression (NICE-PACS)

Product specification
Supersedes data of 2004 Oct 21

2004 Nov 12

New In Car Entertainment car radio tuner IC with Precision Adjacent Channel Suppression (NICE-PACS)

TEA6848H

CONTENTS	12	I ² C-BUS PROTOCOL
1	FEATURES	12.1 I ² C-bus specification
2	GENERAL DESCRIPTION	12.1.1 Data transfer
3	ORDERING INFORMATION	12.1.2 I ² C-bus pull-up resistors
4	QUICK REFERENCE DATA	12.1.3 Frequency setting
5	BLOCK DIAGRAM	12.1.4 Default settings
6	PINNING	12.1.5 Timing requirements
7	FUNCTIONAL DESCRIPTION	12.2 I ² C-bus protocol
7.1	Oscillators	12.2.1 Data transfer mode and IC address
7.1.1	VCO	12.2.2 Write mode: data byte 0
7.1.2	PLL	12.2.3 Write mode: data byte 1
7.1.3	Crystal oscillator	12.2.4 Write mode: data byte 2
7.2	DAA	12.2.5 Write mode: data byte 3
7.3	FM signal channel	12.2.6 Write mode: data byte 4
7.3.1	FM mixer 1	12.2.7 Write mode: data byte 5
7.3.2	Buffer output for weather band flag (pin WBFLAG)	12.2.8 Write mode: data byte 6
7.3.3	FM keyed AGC	12.2.9 Write mode: data byte 7
7.3.4	FM IF amplifier	12.2.10 Read mode: data byte 0
7.3.5	FM mixer 2	13 TEST AND APPLICATION INFORMATION
7.3.6	FM IF2 dynamic selectivity	14 INTERNAL CIRCUITRY
7.3.7	FM quadrature demodulator	15 PACKAGE OUTLINE
7.3.8	Adjacent channel detector and threshold extension	16 SOLDERING
7.3.9	Bandwidth control 'active' flag (pin IFBWFLAG)	16.1 Introduction to soldering surface mount packages
7.3.10	Bandwidth control monitor voltage (pin V _{IFBW})	16.2 Reflow soldering
7.4	AM signal channel	16.3 Wave soldering
7.4.1	AM tuner including mixer 1 and mixer 2	16.4 Manual soldering
7.4.2	AM RF AGC	16.5 Suitability of surface mount IC packages for wave and reflow soldering methods
7.4.3	AM detector	17 DATA SHEET STATUS
7.4.4	AM noise blanker	18 DEFINITIONS
7.5	FM and AM level detector	19 DISCLAIMERS
7.6	IF2 filter gain alignment	20 PURCHASE OF PHILIPS I ² C COMPONENTS
7.7	Frequency offset detector/alignment	
8	LIMITING VALUES	
9	THERMAL CHARACTERISTICS	
10	DC CHARACTERISTICS	
11	AC CHARACTERISTICS	

New In Car Entertainment car radio tuner IC with Precision Adjacent Channel Suppression (NICE-PACS)

TEA6848H

1 FEATURES

- FM mixer 1 for conversion of FM RF (65 to 108 MHz and US weather band) to IF of 10.7 MHz; the mixer provides inherent image rejection; for European and US FM band/WB (weather band) the mixer is driven with a 'high' injection Local Oscillator (LO); in Japan FM band and East Europe FM band the mixer is driven with a 'low' injection LO
- AM mixer 1 for conversion of AM RF to AM IF1 of 10.7 MHz
- LC tuner oscillator providing mixer frequencies for FM mixer and AM mixer 1
- AM mixer 2 for conversion of AM IF1 to AM IF2 of 450 kHz
- Crystal oscillator providing mixer frequencies for AM mixer 2 and FM mixer 2 and reference for synthesizer PLL, IF count, timing for Radio Data System (RDS) update and reference frequency for car audio signal processor ICs
- Fast synthesizer PLL tuning system with local control for inaudible RDS updating
- Timing function for RDS update algorithm and control signal output for car audio signal processor ICs (TEA688x, SAA77xx, TEF689x)
- Digital alignment circuit for bus controlled matching of oscillator tuning voltage to FM antenna tank circuit tuning voltage
- AGC PIN diode drive circuit for FM RF AGC; AGC detection at FM mixer input; the AGC PIN diode drive can be activated by the I²C-bus as a local function for search tuning; AGC threshold is a programmable and keyed function switchable via the I²C-bus
- FM IF linear amplifier with high dynamic input range
- FM mixer 2 for conversion of FM IF1 to FM IF2 of 450 kHz with inherent image rejection
- Fully integrated dynamic selectivity and FM demodulator at IF2; improved sensitivity with dynamic threshold extension; centre frequency of IF2 selectivity alignment via the I²C-bus
- Level detector for AM and FM with temperature compensated output voltage; starting point and slope of level output is programmable via the I²C-bus
- AM cascode AGC stage and RF PIN diode drive circuit; AGC threshold detection at AM mixer 1 and IF2 AGC input; threshold for detection at mixer 1 input is programmable via the I²C-bus
- AM IF2 AGC and demodulator
- AM AF output switchable to provide AM IF2 for AM stereo decoder
- AM noise blanker with detection at IF1 and blanking at AM IF2
- Software controlled flag output
- Buffer output for weather band flag
- Adjacent channel detector, modulation detector and frequency offset for instantaneous bandwidth control of the integrated filter
- Flag and voltage output indicating the actual bandwidth
- I²C-bus alignment of centre frequency and gain variation as functions of bandwidth of the IF2 filter and centre frequency of the offset detector.



2 GENERAL DESCRIPTION

The TEA6848H is a single IC with car radio tuner for AM, FM and Weather Band (WB) intended for microcontroller tuning with the I²C-bus. It provides the following functions:

- AM double conversion receiver for LW, MW and SW (31 m, 41 m and 49 m bands) with IF1 = 10.7 MHz and IF2 = 450 kHz
- FM double conversion receiver with integrated image rejection for IF1 and for IF2 capable of selecting US FM, US weather, Europe FM, East Europe FM and Japan FM bands; fully integrated dynamic selectivity at 450 kHz FM IF2; FM demodulator with dynamic threshold extension; centre frequency alignment of IF2 selectivity via the I²C-bus
- The tuning system includes VCO, crystal oscillator and PLL synthesizer on one chip.

3 ORDERING INFORMATION

TYPE NUMBER	PACKAGE		
	NAME	DESCRIPTION	VERSION
TEA6848H	LQFP80	plastic low profile quad flat package; 80 leads; body 12 × 12 × 1.4 mm	SOT315-1

New In Car Entertainment car radio tuner IC with Precision Adjacent Channel Suppression (NICE-PACS)

TEA6848H

4 QUICK REFERENCE DATA

SYMBOL	PARAMETER	CONDITIONS	MIN.	TYP.	MAX.	UNIT
$V_{DDA(n)}$	analog supply voltage 1 to 4 and 6		8	8.5	9	V
$I_{DDA(tot)}$	sum of analog supply currents 1 to 4 and 6	FM mode	45	56	67	mA
		AM mode	40	50	60	mA
V_{DDA5}	analog supply voltage 5		4.75	5	5.25	V
I_{DDA5}	analog supply current 5	FM mode	–	7.4	–	mA
		AM mode	–	11	–	mA
V_{DDD}	digital supply voltage		4.75	5	5.25	V
I_{DDD}	digital supply current	FM mode	21	26	31	mA
		AM mode	22	27	32	mA
$f_{AM(ant)}$	AM input frequency	LW	0.144	–	0.288	MHz
		MW	0.522	–	1.710	MHz
		SW	5.730	–	9.99	MHz
$f_{FM(ant)}$	FM input frequency		65	–	108	MHz
$f_{FM(WB)(ant)}$	FM weather band input frequency		162.4	–	162.55	MHz
T_{amb}	ambient temperature		–40	–	+85	°C
AM overall system parameters; see Figs 10 and 11						
$(S+N)/N$	signal plus noise-to-noise ratio	$m = 0.3$; $B_{AF} = 2.15$ kHz	–	59	–	dB
THD	total harmonic distortion	$m = 0.8$; $f_{mod} = 1$ kHz	–	0.3	–	%
$V_{sens(rms)}$	sensitivity (RMS value)	$m = 0.3$; $f_{mod} = 1$ kHz; (S+N)/N = 26 dB; with European dummy aerial 15 pF/60 pF; $B_{AF} = 2.15$ kHz	–	45	–	μV
FM overall system parameters; see Figs 10 and 11						
$(S+N)/N$	signal plus noise-to-noise ratio	$\Delta f = 22.5$ kHz; de-emphasis = 50 μs; $B_{AF} = 300$ Hz to 15 kHz	–	63	–	dB
THD	total harmonic distortion	$\Delta f = 75$ kHz; with $2 \times SFE10.7MS3$	–	0.35	–	%
$V_{sens(rms)}$	sensitivity (RMS value)	$\Delta f = 22.5$ kHz; $f_{mod} = 1$ kHz; (S+N)/N = 26 dB; de-emphasis = 50 μs; $B_{AF} = 300$ Hz to 15 kHz; with 75 Ω dummy antenna	–	1.4	2	μV

New In Car Entertainment car radio tuner IC with Precision Adjacent Channel Suppression (NICE-PACS)

TEA6848H

5 BLOCK DIAGRAM

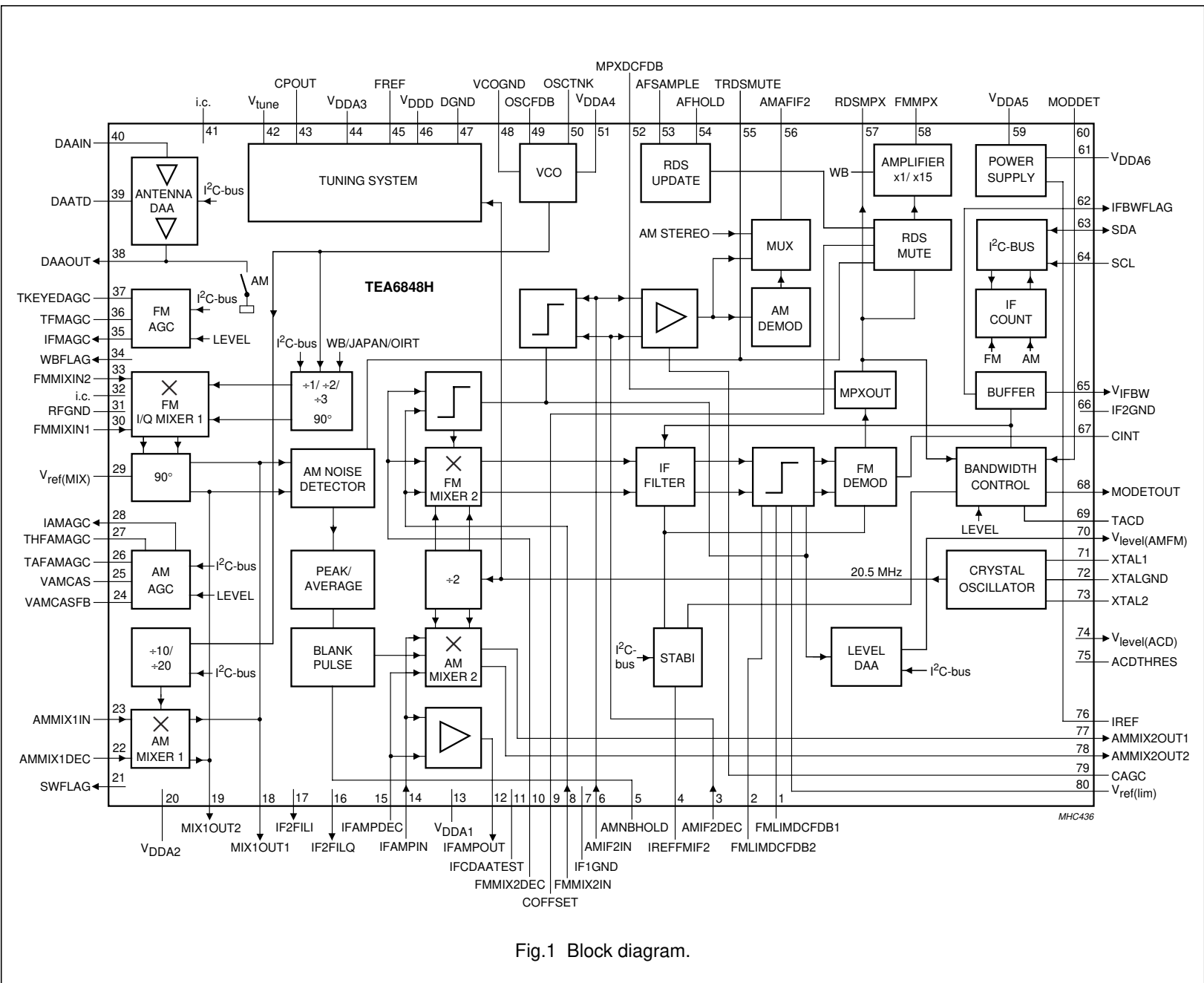

Fig.1 Block diagram.

New In Car Entertainment car radio tuner IC with Precision Adjacent Channel Suppression (NICE-PACS)

TEA6848H

6 PINNING

SYMBOL	PIN	DESCRIPTION
FMLIMDCFDB1	1	decoupling in-phase FM limiter
FMLIMDCFDB2	2	decoupling quadrature phase FM limiter
AMIF2DEC	3	decoupling for AM IF2 input
IREFFMIF2	4	reference current for FM IF2
AMNBHOLD	5	AM noise blanker threshold
AMIF2IN	6	AM IF2 input (450 kHz) for demodulator AGC and AM level detector
IF1GND	7	AM IF1 ground
FMMIX2IN	8	FM mixer 2 input
COFFSET	9	DC feedback for offset compensation RDS mute
FMMIX2DEC	10	FM mixer 2 decoupling
IFCDAATEST	11	test pin for IF centre DAA
IFAMPOUT	12	IF amplifier output (10.7 MHz)
V _{DDA1}	13	analog supply voltage 1 (8.5 V) for FM IF amplifier
IFAMPIN	14	FM IF amplifier and AM mixer 2 input (10.7 MHz)
IFAMPDEC	15	FM IF amplifier and AM mixer 2 decoupling
IF2FILQ	16	test output quadrature phase FM IF2 filter
IF2FILI	17	test output in-phase FM IF2 filter
MIX1OUT1	18	FM mixer and AM mixer 1 IF output 1 (10.7 MHz)
MIX1OUT2	19	FM mixer and AM mixer 1 IF output 2 (10.7 MHz)
V _{DDA2}	20	analog supply voltage 2 (8.5 V) for FM and AM RF
SWFLAG	21	output software programmable flag
AMMIX1DEC	22	AM mixer 1 decoupling
AMMIX1IN	23	AM mixer 1 input
VAMCASFB	24	feedback for cascode AM AGC
VAMCAS	25	cascode AM AGC
TAFAMAGC	26	AF time constant of AM front-end AGC
THFAMAGC	27	HF time constant of AM front-end AGC
IAMAGC	28	PIN diode drive current output of AM front-end AGC
V _{ref(MIX)}	29	reference voltage for FM RF mixer
FMMIXIN1	30	FM RF mixer input 1
RFGND	31	RF ground
i.c.	32	internal connection
FMMIXIN2	33	FM RF mixer input 2
WBFLAG	34	buffered weather band flag output
IFMAGC	35	PIN diode drive current output of FM front-end AGC
TFMAGC	36	time constant of FM front-end AGC
TKEYEDAGC	37	time constant of keyed FM front-end AGC
DAAOUT	38	output of digital auto alignment circuit for antenna tank circuit
DAATD	39	temperature compensation diode for digital auto alignment circuit for antenna tank circuit
DAAIN	40	input of digital auto alignment circuit for antenna tank circuit

New In Car Entertainment car radio tuner IC with Precision Adjacent Channel Suppression (NICE-PACS)

TEA6848H

SYMBOL	PIN	DESCRIPTION
i.c.	41	internal connection
V _{tune}	42	tuning voltage
CPOUT	43	charge pump output
V _{DDA3}	44	analog supply voltage 3 (8.5 V) for tuning PLL
FREF	45	reference frequency output for signal processor IC
V _{DDD}	46	digital supply voltage (5 V)
DGND	47	digital ground
VCOGND	48	VCO ground
OSCFDB	49	VCO feedback
OSCTNK	50	VCO tank circuit
V _{DDA4}	51	analog supply voltage 4 (8.5 V) for VCO
MPXDCFDB	52	DC feedback for FM MPX signal path
AFSAMPLE	53	AF sample flag output for car audio signal processor IC
AFHOLD	54	AF hold flag output for car audio signal processor IC
TRDSMUTE	55	time constant for RDS update mute
AMAFIF2	56	AM demodulator AF output or IF2 output for AM stereo (multiplexed by I ² C-bus)
RDSMPX	57	MPX output for RDS decoder and signal processor (not muted)
FMMPX	58	FM demodulator MPX output
V _{DDA5}	59	analog supply voltage 5 (5 V) for on-chip power supply
MODDET	60	modulation detector input
V _{DDA6}	61	analog supply voltage 6 (8.5 V) for on-chip power supply
IFBWFLAG	62	FM IF2 bandwidth flag output
SDA	63	I ² C-bus data line input and output
SCL	64	I ² C-bus clock line input
V _{IFBW}	65	monitor voltage for FM IF2 bandwidth
IF2GND	66	AM IF2 ground
CINT	67	demodulator loop filter
MODETOUT	68	modulation detector output
TACD	69	adjacent channel detector time constant
V _{level(AMFM)}	70	level voltage output for AM and FM
XTAL1	71	crystal oscillator 1
XTALGND	72	crystal oscillator ground
XTAL2	73	crystal oscillator 2
V _{level(ACD)}	74	level voltage output for adjacent channel detector
ACDTHRES	75	adjacent channel detector threshold
IREF	76	reference current for power supply
AMMIX2OUT1	77	AM mixer 2 output 1 (450 kHz)
AMMIX2OUT2	78	AM mixer 2 output 2 (450 kHz)
CAGC	79	AM IF AGC capacitor/offset detector alignment (FM)
V _{ref(lim)}	80	limiter reference voltage

New In Car Entertainment car radio tuner IC with Precision Adjacent Channel Suppression (NICE-PACS)

TEA6848H

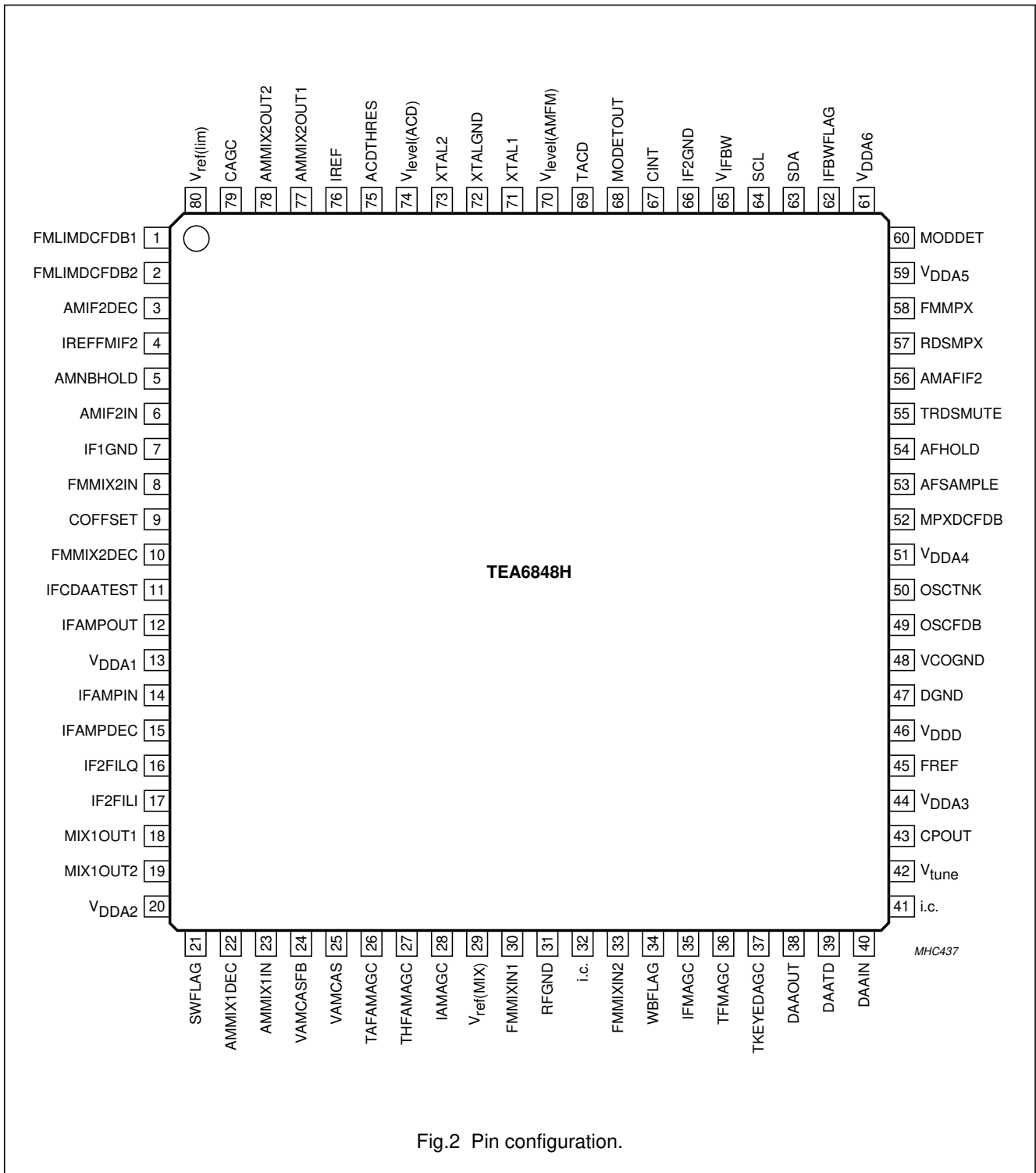

Fig.2 Pin configuration.

New In Car Entertainment car radio tuner IC with Precision Adjacent Channel Suppression (NICE-PACS)

TEA6848H

7 FUNCTIONAL DESCRIPTION

7.1 Oscillators

7.1.1 VCO

The varactor tuned VCO provides the local oscillator signal for both FM and AM mixer 1. It has a frequency range of 162.9 to 248.2 MHz.

7.1.2 PLL

Fast synthesizer PLL tuning system with local control for inaudible RDS updating.

7.1.3 CRYSTAL OSCILLATOR

The crystal oscillator provides a 20.5 MHz signal that is used for:

- Reference frequency for frequency synthesizer PLL
- Local oscillator for AM mixer 2 and FM mixer 2
- Reference frequency for the IF counter
- Timing signal for the RDS update algorithm
- Reference frequency (75.368 kHz) for the TEA688x (car audio signal processor - CASP) or TEF689x (car radio integrated signal processor - CRISP).

7.2 DAA

To reduce the number of manual alignments in production the following I²C-bus controlled Digital Auto Alignment (DAA) functions are included:

- FM RF DAA
 - 7-bit DAA circuitry for the conversion of the VCO tuning voltage to a controlled alignment voltage for the FM antenna tank circuit
- FM and AM level DAA
 - Level DAA circuitry for alignment of slope (3-bit) and starting point (5-bit) of the level curve
- IF2 centre DAA
 - Centre frequency alignment (7-bit) of integrated FM IF2 dynamic selectivity.

7.3 FM signal channel

7.3.1 FM MIXER 1

FM quadrature mixer converts FM RF (65 to 108 MHz and weather band) to IF of 10.7 MHz. The FM mixer provides inherent image rejection and high RF sensitivity.

It is capable of tuning the US FM, US weather, Europe FM, Japan FM and East Europe FM bands:

- US FM = 87.9 to 107.9 MHz
- US weather FM = 162.4 to 162.55 MHz
- Europe FM = 87.5 to 108 MHz
- Japan FM = 76 to 91 MHz
- East Europe FM = 65 to 74 MHz.

7.3.2 BUFFER OUTPUT FOR WEATHER BAND FLAG (PIN WBFLAG)

The buffer output on pin WBFLAG is HIGH for weather band mode.

7.3.3 FM KEYED AGC

The AGC threshold is programmable and the keyed AGC function is switchable via the I²C-bus. AGC detection occurs at the input of the first FM mixer. If the keyed AGC function is activated, the AGC is keyed only by the narrow band level. The AGC PIN diode drive can be activated via the I²C-bus as a local function for search tuning. The AGC sources a constant 10 mA current into the FM PIN diode in AM mode.

7.3.4 FM IF AMPLIFIER

The FM IF amplifier provides 18 dB amplification with high linearity over a wide dynamic range.

7.3.5 FM MIXER 2

The FM mixer 2 converts 10.7 MHz FM IF1 to 450 kHz FM IF2 in I and Q phase to achieve image rejection in the demodulator.

New In Car Entertainment car radio tuner IC with Precision Adjacent Channel Suppression (NICE-PACS)

TEA6848H

7.3.6 FM IF2 DYNAMIC SELECTIVITY

The IF bandwidth of the FM IF2 is automatically adjusted depending on modulation and reception conditions. The centre frequency of the selectivity is adjusted by a 7-bit instruction via the I²C-bus. The dynamic selectivity mode and three fixed bandwidths (**60, 90 and 130 kHz**) can be selected via the I²C-bus. The IF2 bandwidth is set to **13 kHz** in weather band mode.

7.3.7 FM QUADRATURE DEMODULATOR

The FM quadrature demodulator is adjustment free.

7.3.8 ADJACENT CHANNEL DETECTOR AND THRESHOLD EXTENSION

In the event of breakthrough of a strong neighbouring transmitter, the IF2 bandwidth is reduced dynamically. At low RF input voltages and low modulation levels the IF2 bandwidth is reduced to achieve improved sensitivity by demodulator threshold extension.

7.3.9 BANDWIDTH CONTROL 'ACTIVE' FLAG (PIN IFBWFLAG)

Flag output IBFW = 1 from pin IFBWFLAG indicates that the IF2 bandwidth is reduced.

7.3.10 BANDWIDTH CONTROL MONITOR VOLTAGE (PIN V_{IFBW})

The actual bandwidth is indicated by a voltage at pin V_{IFBW} that is proportional, not linear, to the IF bandwidth.

7.4 AM signal channel

7.4.1 AM TUNER INCLUDING MIXER 1 AND MIXER 2

The AM tuner is realized in a double conversion technique and is capable of selecting LW, MW and SW bands.

AM mixer 1 converts AM RF to IF1 of 10.7 MHz, while AM mixer 2 converts IF1 of 10.7 MHz to IF2 of 450 kHz:

- LW = 144 to 288 kHz
- MW = 530 to 1710 kHz (US AM band)
- SW = 5.73 to 9.99 MHz (including the 31 m, 41 m and 49 m bands).

7.4.2 AM RF AGC

The AM wideband AGC in front of the first AM mixer is realized first by a cascaded NPN transistor, which controls the transconductance of the RF amplifier JFET with 10 dB of AGC range. Second, an AM PIN diode stage with antenna type and frequency dependent AGC range is available. The minimum JFET drain source voltage is controlled by a DC feedback loop (pin VAMCASFB) in order to limit the cascode AGC range to 10 dB. If the cascode AGC is not required, a simple RF AGC loop is possible by using only a PIN diode. In this event pins VAMCASFB and VAMCAS have to be open-circuit. In FM mode, the cascade switches off the JFET bias current to reduce total power consumption. The PIN diode is biased by 1 mA in FM mode.

The AGC detection points for AM AGC are at the first AM mixer input (threshold programmable via the I²C-bus) and the IF2 AGC input (fixed threshold).

7.4.3 AM DETECTOR

The AM output provides either a detected AM AF or the corresponding AM IF2 signal. The IF2 signal can be used for AM stereo decoder processing. Soft mute function is controlled by the I²C-bus in AM mono mode.

7.4.4 AM NOISE BLANKER

The detection point for the AM noise blanker is the output stage of AM mixer 1, while blanking is realized at the output of the mixer 2.

Trigger sensitivity can be modified by adding an external resistor at pin AMNBHOLD.

7.5 FM and AM level detector

FM and AM level detectors provide the temperature compensated output voltage. The starting points and slopes of the level detector outputs are programmable via the I²C-bus.

New In Car Entertainment car radio tuner IC with Precision Adjacent Channel Suppression (NICE-PACS)

TEA6848H

7.6 IF2 filter gain alignment

The 4-bit filter gain alignment reduces the change in IF filter gain spread when the bandwidth is changed in dynamic mode from 155 kHz (maximum) to 25 kHz (minimum).

A frequency has to be chosen in the middle of European/US FM band, Japan band or OIRT band (for East Europe) and the IC has to be set into dynamic bandwidth mode (IF2 bandwidth is 155 kHz).

Setting and clearing the FMBW bit continuously allows the adjustment of the gain alignment to minimum change in AM/FM DC level.

7.7 Frequency offset detector/alignment

A very strong undesired neighbouring signal causes offset in the demodulator in case of weak desired input signal.

The frequency offset detector reduces the bandwidth of the IF2 filter when the detected offset in the demodulator is too large.

There are four bits available for frequency offset detector alignment. Every band has to be aligned separately. Tuning has to be set to middle of the band, input signal unmodulated, bit IFBW = 1 (alignment voltage will be given to pin IFBWFLAG). The DC voltage at pin IFBWFLAG has to be aligned to the minimum value.

8 LIMITING VALUES

In accordance with the Absolute Maximum Rating System (IEC 60134).

SYMBOL	PARAMETER	CONDITIONS	MIN.	MAX.	UNIT
V _{DDA1}	analog supply voltage 1 for FM IF amplifier		-0.3	+10	V
V _{DDA2}	analog supply voltage 2 for FM and AM RF		-0.3	+10	V
V _{DDA3}	analog supply voltage 3 for tuning PLL		-0.3	+10	V
V _{DDA4}	analog supply voltage 4 for voltage controlled oscillator		-0.3	+10	V
V _{DDA5}	analog supply voltage 5 for on-chip power supply		-0.3	+6.5	V
V _{DDA6}	analog supply voltage 6 for on-chip power supply		-0.3	+10	V
V _{DD}	digital supply voltage		-0.3	+6.5	V
$\Delta V_{DD8.5-DD5}$	difference between any 8.5 V supply voltage and any 5 V supply voltage	note 1	-0.3	-	V
T _{stg}	storage temperature		-55	+150	°C
T _{amb}	ambient temperature		-40	+85	°C
V _{es}	electrostatic handling voltage	note 2	-200	+200	V
		note 3	-2000	+2000	V

Notes

- To avoid damage and wrong operation it is necessary to keep all 8.5 V supply voltages at a higher level than any 5 V supply voltage. This is also necessary during power-on and power-down sequences. Precautions have to be provided in such a way that interference cannot pull down the 8.5 V supply below the 5 V supply.
- Machine model (R = 0 Ω , C = 200 pF).
- Human body model (R = 1.5 k Ω , C = 100 pF).

9 THERMAL CHARACTERISTICS

SYMBOL	PARAMETER	CONDITIONS	VALUE	UNIT
R _{th(j-a)}	thermal resistance from junction to ambient	in free air	54	K/W
R _{th(j-c)}	thermal resistance from junction to case		9	K/W

New In Car Entertainment car radio tuner IC with Precision Adjacent Channel Suppression (NICE-PACS)

TEA6848H

10 DC CHARACTERISTICS

$V_{DDA(n)} = 8.5 \text{ V}$; $V_{DDA5} = 5 \text{ V}$; $V_{DDD} = 5 \text{ V}$; $T_{\text{amb}} = 25 \text{ }^\circ\text{C}$; tested in the circuit of Figs 10 and 11; unless otherwise specified.

SYMBOL	PARAMETER	CONDITIONS	MIN.	TYP.	MAX.	UNIT
Supply voltage						
$V_{DDA(n)}$	analog supply voltages 1 to 4 and 6		8	8.5	9	V
V_{DDA5}	analog supply voltage 5		4.75	5	5.25	V
V_{DDD}	digital supply voltage		4.75	5	5.25	V
Supply current in FM mode						
I_{DDD}	digital supply current	Europe/US band	21	26	31	mA
		Japan/East Europe band	26.5	33	39.5	mA
I_{DDA1}	analog supply current 1 for FM IF amplifier		5.5	7.3	8.8	mA
I_{DDA2}	analog supply current 2 for FM RF		4.2	5.2	6.2	mA
I_{DDA3}	analog supply current 3 for tuning PLL		3.2	4	4.8	mA
I_{DDA4}	analog supply current 4 for VCO		5.2	6.5	7.8	mA
I_{DDA5}	analog supply current 5 for on-chip power supply	Europe/US band	–	3.8	–	mA
		Japan/East Europe band	–	7.4	–	mA
I_{DDA6}	analog supply current 6 for on-chip power supply		21.5	27	32.5	mA
$I_{MIX1OUT1}$	bias current of FM mixer output 1		4.8	6	7.2	mA
$I_{MIX1OUT2}$	bias current of FM mixer output 2		4.8	6	7.2	mA
Supply current in AM mode						
I_{DDD}	digital supply current		22	27	32	mA
I_{DDA1}	analog supply current 1 for AM mixer 2		100	120	140	μA
I_{DDA2}	analog supply current 2 for RF		1.4	1.8	2.2	mA
I_{DDA3}	analog supply current 3 for tuning PLL		1.8	2.2	2.6	mA
I_{DDA4}	analog supply current 4 for VCO		5	6.5	8	mA
I_{DDA5}	analog supply current 5 for on-chip power supply		–	11	–	mA
I_{DDA6}	analog supply current 6 for on-chip power supply		14	17.5	21	mA
$I_{MIX1OUT1}$	bias current of AM mixer 1 output 1		4.8	6	7.2	mA
$I_{MIX1OUT2}$	bias current of AM mixer 1 output 2		4.8	6	7.2	mA
$I_{AMMIX2OUT1}$	bias current of AM mixer 2 output 1		3.6	4.5	5.4	mA
$I_{AMMIX2OUT2}$	bias current of AM mixer 2 output 2		3.6	4.5	5.4	mA
On-chip power supply reference current generator: pin IREF						
$V_{o(\text{ref})}$	output reference voltage	$R_{IREF} = 120 \text{ k}\Omega$	4	4.25	4.5	V
R_o	output resistance	$R_{IREF} = 120 \text{ k}\Omega$	–	10	–	$\text{k}\Omega$
$I_{o(\text{max})}$	maximum output current	$R_{IREF} = 120 \text{ k}\Omega$	–100	–	+100	nA

New In Car Entertainment car radio tuner IC with Precision Adjacent Channel Suppression (NICE-PACS)

TEA6848H

11 AC CHARACTERISTICS

$V_{DDA(n)} = V_{MIX1OUT1} = V_{MIX1OUT2} = V_{AMMIX2OUT1} = V_{AMMIX2OUT2} = 8.5 \text{ V}$; $V_{DDD} = V_{DDA5} = 5 \text{ V}$; $T_{amb} = 25 \text{ }^\circ\text{C}$; tested in the circuit of Figs 10 and 11; all AC values are given in RMS; unless otherwise specified.

SYMBOL	PARAMETER	CONDITIONS	MIN.	TYP.	MAX.	UNIT
Voltage controlled oscillator						
f_{osc}	oscillator frequency		162.9	–	248.2	MHz
C/N	carrier-to-noise ratio	$f_{osc} = 200 \text{ MHz}$; $\Delta f = 10 \text{ kHz}$	–	97	–	$\frac{\text{dBc}}{\sqrt{\text{Hz}}}$
RR	ripple rejection $\frac{\Delta f_{osc}}{f_{osc}}$	$f_{ripple} = 100 \text{ Hz}$; $V_{DDA4(ripple)} = 100 \text{ mV (RMS)}$; $f_{osc} = 200 \text{ MHz}$	92	99	–	dB
Crystal oscillator						
f_{xtal}	crystal frequency		–	20.5	–	MHz
C/N	carrier-to-noise ratio	$f_{xtal} = 20.5 \text{ MHz}$; $\Delta f = 10 \text{ kHz}$	–	112	–	$\frac{\text{dBc}}{\sqrt{\text{Hz}}}$
CIRCUIT INPUTS: PINS XTAL1, XTALGND AND XTAL2						
$V_{o(osc)(rms)}$	oscillator output voltage (RMS value)	note 1	80	100	160	mV
V_{XTAL1}, V_{XTAL2}	DC bias voltage		1.7	2.1	2.5	V
R_i	real part of input impedance	$V_{XTAL1} - V_{XTAL2} = 1 \text{ mV}$; note 1	–250	–	–	Ω
C_i	input capacitance	note 1	8	10	12	pF
Synthesizer						
PROGRAMMABLE DIVIDER						
N_{prog}	programmable divider ratio		512	–	32767	
ΔN_{step}	programmable divider step size		–	1	–	
CHARGE PUMP: PIN CPOUT						
$I_{sink(cp1)}$	low charge pump 1 sink current	$0.4 \text{ V} < V_{CPOUT} < 7.6 \text{ V}$; data byte 3: bit 0 = 0, bit 1 = 1, bit 2 = 1 for FM weather band; $f_{VCO} > f_{ref} \times \text{divider ratio}$	–	300	–	μA
$I_{source(cp1)}$	low charge pump 1 source current	$0.4 \text{ V} < V_{CPOUT} < 7.6 \text{ V}$; data byte 3: bit 0 = 0, bit 1 = 1, bit 2 = 1 for FM weather band; $f_{VCO} < f_{ref} \times \text{divider ratio}$	–	–300	–	μA
$I_{sink(cp1)h}$	high charge pump 1 sink current	$0.4 \text{ V} < V_{CPOUT} < 7.6 \text{ V}$; data byte 3: bit 0 = 1, bit 1 = 1, bit 2 = 1; AM stereo mode; VCO divider = 10 (LW and MW); $f_{VCO} > f_{ref} \times \text{divider ratio}$	–	1	–	mA

New In Car Entertainment car radio tuner IC with Precision Adjacent Channel Suppression (NICE-PACS)

TEA6848H

SYMBOL	PARAMETER	CONDITIONS	MIN.	TYP.	MAX.	UNIT
$I_{\text{source(cp1)h}}$	high charge pump 1 source current	$0.4 \text{ V} < V_{\text{CPOUT}} < 7.6 \text{ V}$; data byte 3: bit 0 = 1, bit 1 = 1, bit 2 = 1; AM stereo mode; VCO divider = 10 (LW and MW); $f_{\text{VCO}} < f_{\text{ref}} \times \text{divider ratio}$	–	–1	–	mA
$I_{\text{sink(cp2)}}$	charge pump 2 sink current	$0.3 \text{ V} < V_{\text{CPOUT}} < 7.1 \text{ V}$; data byte 3: bit 0 = 0, bit 1 = 0, bit 2 = 0; FM standard mode; $f_{\text{VCO}} > f_{\text{ref}} \times \text{divider ratio}$	–	130	–	μA
$I_{\text{source(cp2)}}$	charge pump 2 source current	$0.3 \text{ V} < V_{\text{CPOUT}} < 7.1 \text{ V}$; data byte 3: bit 0 = 0, bit 1 = 0, bit 2 = 0; FM standard mode; $f_{\text{VCO}} < f_{\text{ref}} \times \text{divider ratio}$	–	–130	–	μA
CHARGE PUMP: PIN V_{tune}						
$I_{\text{sink(cp3)}}$	charge pump 3 sink current	$0.4 \text{ V} < V_{\text{tune}} < 7.6 \text{ V}$; data byte 3: bit 0 = 0, bit 1 = 0, bit 2 = 0; FM standard mode; $f_{\text{VCO}} > f_{\text{ref}} \times \text{divider ratio}$	–	3	–	mA
$I_{\text{source(cp3)}}$	charge pump 3 source current	$0.4 \text{ V} < V_{\text{tune}} < 7.6 \text{ V}$; data byte 3: bit 0 = 0, bit 1 = 0, bit 2 = 0; FM standard mode; $f_{\text{VCO}} < f_{\text{ref}} \times \text{divider ratio}$	–	–3	–	mA
Antenna Digital Auto Alignment (DAA)						
DAA INPUT: PIN DAAIN						
$I_{\text{bias(cp)}}$	charge pump buffer input bias current	$V_{\text{DAAIN}} = 0.4 \text{ to } 8 \text{ V}$	–10	–	+10	nA
$V_{\text{i(cp)}}$	charge pump buffer input voltage		0	–	8.5	V
DAA OUTPUT: PIN DAAOUT; note 2						
$V_{\text{o(AM)}}$	DAA output voltage in AM mode	$I_{\text{DAAOUT}} < 100 \mu\text{A}$	–	–	0.3	V
$V_{\text{o(FM)}}$	DAA output voltage in FM mode	minimum value; data byte 2 = 10000000; $V_{\text{DAAIN}} = 0.5 \text{ V}$; $V_{\text{DAATD}} = 0.45 \text{ V}$	–	–	0.5	V
		maximum value; data byte 2 = 11111111; $V_{\text{DAAIN}} = 4.7 \text{ V}$; $V_{\text{DAATD}} = 0.45 \text{ V}$	8	–	8.5	V
		$V_{\text{DAAIN}} = 4 \text{ V}$; $V_{\text{DAATD}} = 0.45 \text{ V}$ data byte 2 = 10000000	–	0.65	–	V
		data byte 2 = 11000000	3.8	4	4.2	V
$V_{\text{o(FM)}}$	DAA output voltage in FM mode	$V_{\text{DAAIN}} = 2 \text{ V}$; $V_{\text{DAATD}} = 0.45 \text{ V}$ data byte 2 = 11010101	2.3	2.6	2.9	V
		data byte 2 = 10101010	1.2	1.4	1.6	V

New In Car Entertainment car radio tuner IC with Precision Adjacent Channel Suppression (NICE-PACS)

TEA6848H

SYMBOL	PARAMETER	CONDITIONS	MIN.	TYP.	MAX.	UNIT
$V_{o(n)}$	DAA output noise voltage	data byte 2 = 11000000; FM mode; $V_{DAAIN} = 4\text{ V}$; $V_{DAATD} = 0.45\text{ V}$; $B = 300\text{ Hz to }22\text{ kHz}$	–	30	100	μV
$\Delta V_{o(T)}$	DAA output voltage variation with temperature	$T_{amb} = -40\text{ to }+85\text{ }^\circ\text{C}$; data byte 2 = 11000000	–8	–	+8	mV
$\Delta V_{o(step)}$	DAA step accuracy	$n = 0\text{ to }127$; FM mode; $V_{DAAOUT} = 0.5\text{ to }8\text{ V}$; $V_{DAAIN} = 2\text{ V}$; $V_{DAATD} = 0.45\text{ V}$	$0.5V_{LSB}$	V_{LSB}	$1.5V_{LSB}$	mV
$\Delta V_{o(sink)}$	DAA output variation caused by sink current	$V_{DAAIN} = 4\text{ V}$; $I_L = 50\text{ }\mu\text{A}$	$-V_{LSB}$	–	$+V_{LSB}$	
$\Delta V_{o(source)}$	DAA output variation caused by source current	$V_{DAAIN} = 4\text{ V}$; $I_L = -50\text{ }\mu\text{A}$	$-V_{LSB}$	–	$+V_{LSB}$	
t_{st}	DAA output settling time	$V_{DAAOUT} = 0.2\text{ to }8.25\text{ V}$; $C_L = 270\text{ pF}$	–	20	30	μs
RR	ripple rejection $\frac{V_{DAAOUT}}{V_{DDA3}}$	data byte 2 = 10101011; FM mode; $V_{DAAIN} = 4\text{ V}$; $V_{DAATD} = 0.45\text{ V}$; $f_{ripple} = 100\text{ Hz}$; $V_{DDA3(ripple)} = 100\text{ mV (RMS)}$	–	65	–	dB
C_L	DAA output load capacitance		–	–	270	pF
DAA TEMPERATURE COMPENSATION: PIN DAATD						
I_{source}	compensation diode source current	$V_{DAATD} = 0.2\text{ to }1.2\text{ V}$	–50	–40	–30	μA
TC_{source}	temperature coefficient of compensation diode source current	$V_{DAATD} = 0.2\text{ to }1.2\text{ V}$; $T_{amb} = -40\text{ to }+85\text{ }^\circ\text{C}$	–300	–	+300	$\frac{10^{-6}}{\text{K}}$
IF counter (FM IF2 or AM IF2 counter)						
N_{IF}	IF counter length for AM and FM		–	8	–	bit
PINS FMMIX2IN AND FMMIX2DEC; note 3						
$V_{sens(rms)}$	sensitivity voltage (RMS value)	FM mode	–	30	100	μV
N	counter result (decimal)	period = 2 ms; $V_{FMMIX2IN-FMMIX2DEC} = 100\text{ }\mu\text{V}$ prescaler ratio = 10	–	90	–	
		prescaler ratio = 40	–	22	–	
		period = 20 ms; $V_{FMMIX2IN-FMMIX2DEC} = 100\text{ }\mu\text{V}$ prescaler ratio = 10	–	132	–	
		prescaler ratio = 40	–	225	–	

New In Car Entertainment car radio tuner IC with Precision Adjacent Channel Suppression (NICE-PACS)

TEA6848H

SYMBOL	PARAMETER	CONDITIONS	MIN.	TYP.	MAX.	UNIT
PINS AMIF2IN AND AMIF2DEC; note 4						
$V_{\text{sens(rms)}}$	sensitivity voltage (RMS value)	AM mode; $m = 0$	–	30	70	μV
N	counter result (decimal)	period = 2 ms; $V_{\text{AMIF2IN-AMIF2DEC}} = 200 \mu\text{V}$	–	132	–	
		period = 20 ms; $V_{\text{AMIF2IN-AMIF2DEC}} = 200 \mu\text{V}$	–	40	–	
Reference frequency for car signal processor IC TEA688x and TEF689x; note 5						
REFERENCE FREQUENCY DIVIDER						
N_{ref}	crystal oscillator divider ratio		–	272	–	
f_{ref}	reference frequency	$f_{\text{xtal}} = 20.5 \text{ MHz}$	–	75.368	–	kHz
VOLTAGE GENERATOR: PIN FREF						
$V_{\text{o(p-p)}}$	AC output voltage (peak-to-peak value)	not loaded	60	90	–	mV
V_{O}	DC output voltage		3.2	3.4	3.7	V
R_{o}	output resistance		–	–	50	$\text{k}\Omega$
$R_{\text{L(min)}}$	minimum load resistance for first I ² C-bus address		1	–	–	$\text{M}\Omega$
Weather band flag: pin WBFLAG						
$I_{\text{source(max)}}$	maximum source current		–	–5	–	mA
$R_{\text{i(shunt)}}$	internal shunt resistance to ground		–	50	–	$\text{k}\Omega$
$V_{\text{o(max)}}$	maximum output voltage for FM mode	measured with respect to pin RFGND	0	–	0.2	V
V_{O}	output voltage for weather band mode	measured with respect to pin RFGND	4	–	5	V
AM signal channel						
AM RF AGC STAGE (PIN DIODE DRIVE)						
$V_{\text{i(p)}}$	RF input voltage for wideband AGC start level (peak value)	$m = 0.3$; data byte 4: bit 5 = 0, bit 6 = 0	–	150	–	mV
		$m = 0.3$; data byte 4: bit 5 = 1, bit 6 = 0	–	275	–	mV
		$m = 0.3$; data byte 4: bit 5 = 0, bit 6 = 1	–	400	–	mV
		$m = 0.3$; data byte 4: bit 5 = 1, bit 6 = 1	–	525	–	mV
AM IF AGC STAGE INPUT: PIN AMIF2IN						
$V_{\text{i(p)}}$	IF2 input voltage (peak value)	AGC start level	0.20	0.27	0.35	V

New In Car Entertainment car radio tuner IC with Precision Adjacent Channel Suppression (NICE-PACS)

TEA6848H

SYMBOL	PARAMETER	CONDITIONS	MIN.	TYP.	MAX.	UNIT
AM RF AGC CURRENT GENERATOR OUTPUT: PIN IAMAGC						
$I_{\text{sink(max)}}$	maximum AGC sink current	$V_o = 2.8 \text{ V}$	11	15	19	mA
I_{sink}	AGC sink current	FM mode	1	–	–	mA
R_o	output resistance	$I_o = 1 \mu\text{A}$	0.5	–	–	M Ω
C_o	AM AGC current generator output capacitance		–	5	7	pF
RF CASCODE AGC						
$I_{\text{cas(off)}}$	AM cascode off current	FM mode	–	–	100	nA
Pin VAMCASFB						
$V_{\text{cas(FB)}}$	cascode feedback voltage	$V_{\text{AMMIX1IN-AMMIX1DEC}}$ above threshold; minimum gain	–	0.26	–	V
$I_{\text{cas(FB)}}$	cascode feedback sense current		0	–	1	μA
Pin VAMCAS						
V_{cas}	cascode voltage	$V_{\text{AMMIX1IN-AMMIX1DEC}}$ below threshold; maximum gain	–	5	–	V
I_{cas}	cascode transistor base current capability		100	–	–	μA
AM MIXER 1 (IF1 = 10.7 MHz)						
Mixer inputs: pins AMMIX1DEC and AMMIX1IN						
R_i	input resistance	note 6	15	25	40	k Ω
C_i	input capacitance	note 6	2.5	5	7.5	pF
V_i	DC input voltage		2.3	2.7	3.1	V
$V_{i(\text{max})}$	maximum input voltage	1 dB compression point of $V_{\text{MIX1OUT1-MIX1OUT2}}$; $m = 0$	500	–	–	mV
Mixer outputs: pins MIX1OUT1 and MIX1OUT2						
R_o	output resistance	note 7	100	–	–	k Ω
C_o	output capacitance	note 7	–	4	7	pF
$V_{o(\text{max})(\text{p-p})}$	maximum output voltage (peak-to-peak value)		12	15	–	V
I_{bias}	mixer bias current	AM mode	4.8	6	7.2	mA
Mixer						
$g_{m(\text{conv})}$	conversion transconductance $\frac{I_{\text{MIX1OUT}}}{V_{\text{MIX1IN}}}$		2.0	2.55	3.2	$\frac{\text{mA}}{\text{V}}$

New In Car Entertainment car radio tuner IC with Precision Adjacent Channel Suppression (NICE-PACS)

TEA6848H

SYMBOL	PARAMETER	CONDITIONS	MIN.	TYP.	MAX.	UNIT
$g_{m(\text{conv})(T)}$	conversion transconductance variation with temperature $\frac{\Delta g_{m(\text{conv})}}{g_{m(\text{conv})} \times \Delta T}$		–	-9×10^{-4}	–	K^{-1}
IP3	3rd-order intermodulation	$R_L = 2.6 \text{ k}\Omega$ (AC load between output pins); $\Delta f = 300 \text{ kHz}$	135	138	–	$\text{dB}\mu\text{V}$
IP2	2nd-order intermodulation	$R_L = 2.6 \text{ k}\Omega$ (AC load between output pins)	–	170	–	$\text{dB}\mu\text{V}$
$V_{i(n)(\text{eq})}$	equivalent input noise voltage	band limited noise; $R_{\text{gen}} = 750 \text{ }\Omega$; $R_L = 2.6 \text{ k}\Omega$ (AC load between output pins)	–	5.8	8	$\frac{\text{nV}}{\sqrt{\text{Hz}}}$
F	noise figure of AM mixer 1		–	4.5	7.1	dB
AM MIXER 2 (IF2 = 450 kHz)						
<i>Mixer inputs: pins IFAMPIN and IFAMPDEC</i>						
R_i	input resistance	note 8	–	330	–	Ω
C_i	input capacitance	note 8	–	5	7	pF
V_I	DC voltage		2.4	2.7	3	V
$V_{i(\text{max})(\text{p})}$	maximum input voltage (peak value)	1 dB compression point of $V_{\text{AMMIX2OUT1-AMMIX2OUT2}}$	1.1	1.4	–	V
<i>Mixer outputs: pins AMMIX2OUT1 and AMMIX2OUT2</i>						
R_o	output resistance	note 9	50	–	–	$\text{k}\Omega$
C_o	output capacitance	note 9	–	4	7	pF
$V_{o(\text{max})(\text{p-p})}$	maximum output voltage (peak-to-peak value)	$V_{\text{DDA6}} = 8.5 \text{ V}$	12	15	–	V
I_{bias}	mixer bias current	AM mode	3.6	4.5	5.4	mA
<i>Mixer</i>						
$g_{m(\text{conv})}$	conversion transconductance $\frac{I_{\text{AMMIX2OUT}}}{V_{\text{IFAMPIN}}}$		1.3	1.6	1.9	$\frac{\text{mA}}{\text{V}}$
$g_{m(\text{conv})(T)}$	conversion transconductance variation with temperature $\frac{\Delta g_{m(\text{conv})}}{g_{m(\text{conv})} \times \Delta T}$		–	-9×10^{-4}	–	K^{-1}
IP3	3rd-order intermodulation	$R_L = 1.5 \text{ k}\Omega$ (AC load between output pins); $\Delta f = 300 \text{ kHz}$	134	137	–	$\text{dB}\mu\text{V}$
IP2	2nd-order intermodulation	$R_L = 1.5 \text{ k}\Omega$ (AC load between output pins)	–	170	–	$\text{dB}\mu\text{V}$
$V_{i(n)(\text{eq})}$	equivalent input noise voltage	$R_{\text{gen}} = 330 \text{ }\Omega$; $R_L = 1.5 \text{ k}\Omega$ (AC load between output pins)	–	15	22	$\frac{\text{nV}}{\sqrt{\text{Hz}}}$

New In Car Entertainment car radio tuner IC with Precision Adjacent Channel Suppression (NICE-PACS)

TEA6848H

SYMBOL	PARAMETER	CONDITIONS	MIN.	TYP.	MAX.	UNIT
F	noise figure of AM mixer 2		–	16	19.5	dB
I_L	mixer leakage current	FM mode	–	–	10	μ A
AM IF2 AGC STAGE: PINS AMIF2IN AND AMIF2DEC; note 4						
V_i	input voltage	audio attenuation $\alpha = -10$ dB	–	25	40	μ V
		data byte 4: bit 4 = 1; mute on data byte 4: bit 4 = 0; mute off	–	6	10	μ V
$V_{AGC(start)}$	AGC start voltage	input carrier voltage	–	14	30	μ V
$V_{AGC(stop)}$	AGC stop voltage	maximum input peak voltage	1	–	–	V
$V_{AGC(ctrl)}$	AGC control voltage	$V_i = 1$ mV	4.1	4.3	4.7	V
ΔAGC	AGC range	between start and stop of AGC	–	89	–	dB
R_i	input resistance		1.8	2	2.2	k Ω
C_i	input capacitance		–	10	15	pF
AM DETECTOR						
$V_{sens(rms)}$	sensitivity voltage (RMS value)	$m = 0.3$; $f_{mod} = 400$ Hz; $B_{AF} = 2.15$ kHz; $R_{gen} = 2$ k Ω ; note 4	–	45	65	μ V
		(S+N)/N = 26 dB (S+N)/N = 46 dB	–	600	900	μ V
(S+N)/N	maximum signal plus noise-to-noise ratio	$m = 0.3$; $f_{mod} = 400$ Hz; $B_{AF} = 2.15$ kHz; $R_{gen} = 2$ k Ω	–	60	–	dB
THD	total harmonic distortion	$B_{AF} = 2.15$ kHz; $C_{AGC} = 10$ μ F; $V_{AMIF2IN} = 100$ μ V to 250 mV (RMS)	–	–	–	–
		$m = 0.8$; $f_{mod} = 400$ Hz	–	0.5	1	%
		$m = 0.8$; $f_{mod} = 100$ Hz	–	1.25	2.5	%
t_{sw}	FM to AM switching time	$V_{AMIF2IN} = 100$ μ V; $C_{AGC} = 10$ μ F	–	1000	1500	ms
t_{st}	AM AGC settling time	$V_{AMIF2IN} = 100$ μ V to 100 mV	–	400	600	ms
		$V_{AMIF2IN} = 100$ mV to 100 μ V	–	600	900	ms
<i>Output: pin AMAFIF2</i>						
$V_{o(rms)}$	AM IF2 output voltage (RMS value)	AM stereo; $m = 0$; data byte 3: bit 0 = 1, bit 1 = 1, bit 2 = 1	1.5	3	4.5	mV
		minimum at $V_{AMIF2IN} = 14$ μ V maximum at $V_{AMIF2IN} = 5$ mV	130	180	230	mV
		AM mono; $m = 0.3$; data byte 3: bit 0 = 1, bit 1 = 0, bit 2 = 1; $f_{mod} = 400$ Hz; $V_{AMIF2IN} = 100$ μ V to 500 mV (RMS)	200	250	300	mV
R_o	output resistance	data byte 3: bit 0 = 1, bit 1 = 1, bit 2 = 1; AM stereo	–	–	500	Ω
		data byte 3: bit 0 = 1, bit 1 = 0, bit 2 = 1; AM mono	–	–	500	Ω

New In Car Entertainment car radio tuner IC with Precision Adjacent Channel Suppression (NICE-PACS)

TEA6848H

SYMBOL	PARAMETER	CONDITIONS	MIN.	TYP.	MAX.	UNIT
C _o	output capacitance	data byte 3: bit 0 = 1, bit 1 = 0, bit 2 = 1	–	5	7	pF
Z _L	load impedance	data byte 3: bit 0 = 1, bit 1 = 0, bit 2 = 1; AM mono	100	–	–	kΩ
		data byte 3: bit 0 = 1, bit 1 = 1, bit 2 = 1; AM stereo	10	–	–	kΩ
RR	ripple rejection	V _{DDA5(ripple)} = 100 mV (RMS); f _{ripple} = 100 Hz	–	24	–	dB
		V _{DDA6(ripple)} = 100 mV (RMS); f _{ripple} = 100 Hz	–	26	–	dB
AM IF2 LEVEL DETECTOR OUTPUT: PIN V _{level(AMFM)} ; see Fig.4						
V _{level(AMFM)}	DC output voltage	V _{AMIF2IN} = 10 μV to 1 V	0	–	7	V
		V _{AMIF2IN} < 1 μV; standard setting of level DAA	0.1	0.5	0.9	V
		V _{AMIF2IN} = 1.4 mV; standard setting of level DAA	1.6	2.2	2.8	V
ΔV _{level(AMFM)}	step size for adjustment of level starting point	V _{AMIF2IN} = 0 V; standard setting of level slope	30	40	50	mV
V _{level(slope)}	slope of level voltage	V _{AMIF2IN} = 140 μV to 140 mV; standard setting of level slope	650	800	950	$\frac{\text{mV}}{20 \text{ dB}}$
ΔV _{step}	step size for adjustment of level slope	V _{AMIF2IN} = 1.4 mV	45	60	75	$\frac{\text{mV}}{20 \text{ dB}}$
B _{level(AMFM)}	bandwidth of level output voltage	V _{AMIF2IN} = 15 mV; standard setting of level DAA	200	300	–	kHz
R _o	output resistance		–	–	500	Ω
RR	ripple rejection $\frac{V_{\text{level}}}{V_{\text{DDA6}}}$	V _{DDA6(ripple)} = 100 mV (RMS); f _{ripple} = 100 Hz	–	36	–	dB
AM NOISE BLANKER; TEST SIGNAL AND TEST CIRCUIT; see Fig.5						
<i>Threshold: pin AMNBHOLD</i>						
V _O	DC output voltage		4.3	4.6	5.1	V
t _{sup}	suppression time	V _{pulse} = 200 mV (peak); V _{level(AMFM)} < 1.8 V	6	7.5	10	μs
f _{trigger}	trigger sensitivity frequency	V _{pulse} = 200 mV (peak); V _{level(AMFM)} < 1.8 V	–	1000	–	Hz
		V _{pulse} = 200 mV (peak); V _{level(AMFM)} > 2.2 V	–	–	100	Hz
		V _{pulse} = 20 mV (peak); V _{level(AMFM)} < 1.8 V	–	–	100	Hz
<i>Noise detector output: pin TRDSMUTE</i>						
I _{sink(AGC)}	AM noise blanker AGC sink current	V _{TRDSMUTE} = 3 V	35	50	65	μA

New In Car Entertainment car radio tuner IC with Precision Adjacent Channel Suppression (NICE-PACS)

TEA6848H

SYMBOL	PARAMETER	CONDITIONS	MIN.	TYP.	MAX.	UNIT
V_{AGC}	AM noise blanker AGC voltage	AM mixer 1 input $V_i = 0$ V	1.9	2.2	2.5	V
FM signal channel						
FM RF AGC (FM DISTANCE MODE; DATA BYTE 4: BIT 3 = 0)						
<i>Inputs: pins FMMIXIN1 and FMMIXIN2; note 10</i>						
$V_{i(RF)(rms)}$	RF input voltage for start of wideband AGC (RMS value)	data byte 4: bit 5 = 1, bit 6 = 1	–	3	–	mV
		data byte 4: bit 5 = 0, bit 6 = 1	–	6	–	mV
		data byte 4: bit 5 = 1, bit 6 = 0	–	9	–	mV
		data byte 4: bit 5 = 0, bit 6 = 0	–	12	–	mV
<i>Pin TFMAGC</i>						
R_{source}	source resistance		4	5	6	k Ω
$V_{O(ref)}$	DC output reference voltage	data byte 4: bit 5 = 0, bit 6 = 0; $V_{FMMIXIN1-FMMIXIN2} = 0$ V	4.1	4.6	5.1	V
<i>PIN diode drive output: pin IFMAGC</i>						
$I_{sink(AGC)(max)}$	maximum AGC sink current	$V_{IFMAGC} = 2.5$ V; $V_{TFMAGC} = V_{O(ref)} - 0.5$ V; data byte 4: bit 5 = 0, bit 6 = 0, bit 7 = 0	8	11.5	15	mA
$I_{source(AGC)(max)}$	maximum AGC source current	$V_{IFMAGC} = 2.5$ V; $V_{TFMAGC} = V_{O(ref)} + 0.5$ V; data byte 4: bit 5 = 0, bit 6 = 0, bit 7 = 0	–15	–11.5	–8	mA
$I_{source(AGC)}$	AGC source current	AM mode	–15	–11.5	–8	mA
		$V_{IFMAGC} = 2.5$ V; data byte 4: bit 3 = 1 (FM local)	–0.65	–0.5	–0.35	mA
<i>Level voltage output: pin $V_{level(AMFM)}$</i>						
V_{th}	threshold voltage for narrow-band AGC	data byte 4: bit 5 = 0, bit 6 = 0, bit 7 = 1; keyed AGC	500	950	1400	mV
FM RF MIXER						
<i>Reference voltage: pin $V_{ref(MIX)}$</i>						
V_{ref}	reference voltage	FM mode	6.5	7.1	7.9	V
		AM mode	2.7	3.1	3.4	V
<i>Inputs: pins FMMIXIN1 and FMMIXIN2; note 10</i>						
$V_{i(RF)(max)}$	maximum RF input voltage	1 dB compression point of FM mixer output voltage (peak-to-peak value)	70	100	–	mV
$V_{i(n)(eq)}$	equivalent input noise voltage	$R_{gen} = 200$ Ω ; $R_L = 2.6$ k Ω	–	2.6	3.1	$\frac{nV}{\sqrt{Hz}}$
R_i	input resistance		1.4	2.8	4.2	k Ω
C_i	input capacitance		–	5	7	pF

New In Car Entertainment car radio tuner IC with Precision Adjacent Channel Suppression (NICE-PACS)

TEA6848H

SYMBOL	PARAMETER	CONDITIONS	MIN.	TYP.	MAX.	UNIT
<i>Outputs: pins MIX1OUT1 and MIX1OUT2; note 7</i>						
R_o	output resistance		100	–	–	k Ω
C_o	output capacitance		2	3.5	5	pF
I_{bias}	mixer bias current	FM mode	4.8	6	7.2	mA
$V_{o(max)(p-p)}$	maximum output voltage (peak-to-peak value)		3	–	–	V
<i>FM mixer</i>						
$g_{m(conv)}$	conversion transconductance		8.5	12.5	18	$\frac{mA}{V}$
$g_{m(conv)(T)}$	conversion transconductance variation with temperature		–	-1×10^{-3}	–	K $^{-1}$
F	noise figure		–	3	4.6	dB
$R_{gen(opt)}$	optimum generator resistance		–	200	–	Ω
IP3	3rd-order intermodulation		113	116	–	dB μ V
IRR	image rejection ratio $\frac{V_{MIX1OUTwanted}}{V_{MIX1OUTimage}}$	$f_{RFwanted} = 87.5$ MHz; $f_{RFimage} = 108.9$ MHz	25	30	–	dB
		data byte 3 = X010X110; $f_{RFwanted} = 162.475$ MHz; $f_{RFimage} = 183.875$ MHz; weather band mode; $f_{ref} = 25$ kHz	22	30	–	dB
<i>IF AMPLIFIER</i>						
G	gain	$R_L = 330 \Omega$; $V_{IFAMPIN} = 1$ mV; note 8	15	17	19	dB
F	noise figure		–	10	13	dB
IP3	3rd-order intermodulation		113	116	–	dB μ V
<i>Inputs: pins IFAMPIN and IFAMPDEC; note 8</i>						
$V_{i(max)(p)}$	maximum input voltage (peak value)	1 dB compression point of IF amplifier output voltage (peak value)	200	–	–	mV
$V_{i(n)(eq)}$	equivalent input noise voltage	$R_{gen} = 330 \Omega$; $R_L = 330 \Omega$	–	8	10	$\frac{nV}{\sqrt{Hz}}$
R_i	input resistance		270	330	390	Ω
C_i	input capacitance		–	5	7	pF
<i>Output: pin IFAMPOUT</i>						
$V_{o(max)(p)}$	maximum output voltage (peak value)		1.2	1.5	–	V
R_o	output resistance		270	330	390	Ω
C_o	output capacitance		–	5	7	pF

New In Car Entertainment car radio tuner IC with Precision Adjacent Channel Suppression (NICE-PACS)

TEA6848H

SYMBOL	PARAMETER	CONDITIONS	MIN.	TYP.	MAX.	UNIT
Tunable filter						
B _{max}	maximum bandwidth	data byte 4: bit 1 = 0, bit 0 = 0; dynamic mode	–	160	–	kHz
B _{min}	minimum bandwidth	data byte 4: bit 1 = 0, bit 0 = 0; dynamic mode; V _{TACD} = 4.2 V	–	25	–	kHz
B ₁₃	bandwidth in weather band mode		–	13	–	kHz
B ₆₀	bandwidth in narrow band mode	data byte 4: bit 1 = 1, bit 0 = 1	–	60	–	kHz
B ₉₀	bandwidth in mid band mode	data byte 4: bit 1 = 1, bit 0 = 0	–	90	–	kHz
B ₁₃₀	bandwidth in wideband mode	data byte 4: bit 1 = 0, bit 0 = 1	–	130	–	kHz
PIN V _{IFBW}						
V _o	monitor output voltage for IF2 bandwidth	fixed bandwidth = narrow	–	1.35	–	V
		fixed bandwidth = mid	–	0.94	–	V
		fixed bandwidth = wide	–	0.55	–	V
R _o	output resistance		–	5	–	kΩ
Adjacent channel detector						
MODULATION DETECTOR INPUT: PIN MODDET						
R _i	input resistance		–	42.4	–	kΩ
C _i	input capacitance		–	5	7	pF
MODULATION DETECTOR OUTPUT: PIN MODETOUT						
R _o	output resistance		–	33.9	–	kΩ
DETECTOR ADJUST: PIN ACDTHRES						
R _i	input resistance		6.2	7.8	9.4	kΩ
C _i	input capacitance		–	5	7	pF
FM demodulator and level detector; see Figs 6 and 7						
FM DEMODULATOR						
<i>FM mixer 2 input: pins FMMIX2IN and FMMIX2DEC; note 3</i>						
V _{start(lim)(rms)}	start of limiting of RDS MPX output voltage (RMS value)	α _{AF} = –3 dB	–	4.5	–	μV
V _{o(sens)(rms)}	sensitivity for RDS MPX output voltage (RMS value)	Δf = 22.5 kHz; f _{mod} = 1 kHz; de-emphasis = 50 μs	–	–	–	–
		R _{gen} = 165 Ω; (S+N)/N = 26 dB	–	11	–	μV
		(S+N)/N = 46 dB	–	90	–	μV

New In Car Entertainment car radio tuner IC with Precision Adjacent Channel Suppression (NICE-PACS)

TEA6848H

SYMBOL	PARAMETER	CONDITIONS	MIN.	TYP.	MAX.	UNIT
<i>RDS MPX output: pin RDSMPX</i>						
(S+N)/N	maximum signal plus noise-to-noise ratio of RDS MPX output voltage	$\Delta f = 22.5 \text{ kHz}; f_{\text{mod}} = 1 \text{ kHz};$ de-emphasis = 50 $\mu\text{s};$ $V_{\text{FMMIX2IN}} = 10 \text{ mV}$	65	68	–	dB
THD	total harmonic distortion of RDS MPX output voltage	$\Delta f = 75 \text{ kHz}; f_{\text{mod}} = 1 \text{ kHz};$ de-emphasis = 50 $\mu\text{s};$ $V_{\text{FMMIX2IN}} = 200 \mu\text{V to } 800 \text{ mV}$	–	0.35	0.7	%
α_{AM}	AM suppression $\frac{V_{\text{o(rms)}}}{V_{\text{o(AM)(rms)}}$	FM: $\Delta f = 22.5 \text{ kHz}; f_{\text{mod}} = 1 \text{ kHz};$ AM: $m = 0.3; f_{\text{mod}} = 1 \text{ kHz};$ de-emphasis = 50 μs $V_{\text{FMMIX2IN}} = 30 \text{ to } 70 \mu\text{V}$	20	30	–	dB
		$V_{\text{FMMIX2IN}} = 70 \text{ to } 500 \mu\text{V}$	30	40	–	dB
		$V_{\text{FMMIX2IN}} = 500 \mu\text{V to } 300 \text{ mV}$	35	45	–	dB
		$V_{\text{FMMIX2IN}} = 300 \text{ mV to } 1 \text{ V}$	30	40	–	dB
$V_{\text{o(rms)}}$	RDS MPX output voltage (RMS value)	$V_{\text{FMMIX2IN}} = 20 \mu\text{V to } 1 \text{ V};$ note 3 $\Delta f = 5 \text{ kHz}; f_{\text{mod}} = 57 \text{ kHz}$	45	50	55	mV
		$\Delta f = 22.5 \text{ kHz}; f_{\text{mod}} = 1 \text{ kHz}$	205	230	255	mV
$I_{\text{o(max)(rms)}}$	maximum RDS MPX output current (RMS value)		100	–	–	μA
R_{o}	output resistance		–	–	500	Ω
R_{L}	load resistance		20	–	–	$\text{k}\Omega$
C_{L}	load capacitance		–	–	50	pF
B	bandwidth RDS MPX output	$C_{\text{L}} = 0; R_{\text{L}} > 20 \text{ k}\Omega$	200	300	–	kHz
PSRR	power supply ripple rejection	$f_{\text{ripple}} = 100 \text{ Hz to } 20 \text{ kHz}$	–	40	–	dB
<i>FM MPX output: pin FMMPX; note 3</i>						
(S+N)/N	maximum signal plus noise-to-noise ratio of FM MPX output voltage	$\Delta f = 22.5 \text{ kHz}; f_{\text{mod}} = 1 \text{ kHz};$ de-emphasis = 50 $\mu\text{s};$ $V_{\text{FMMIX2IN}} = 10 \text{ mV}$	65	68	–	dB
THD	total harmonic distortion of FM MPX output voltage	$\Delta f = 75 \text{ kHz}; f_{\text{mod}} = 1 \text{ kHz};$ de-emphasis = 50 $\mu\text{s};$ $V_{\text{FMMIX2IN}} = 200 \mu\text{V to } 800 \text{ mV}$	–	0.1	0.3	%
α_{AM}	AM suppression $\frac{V_{\text{o(rms)}}}{V_{\text{o(AM)(rms)}}$	FM: $\Delta f = 22.5 \text{ kHz}; f_{\text{mod}} = 1 \text{ kHz};$ AM: $m = 0.3; f_{\text{mod}} = 1 \text{ kHz};$ de-emphasis = 50 μs $V_{\text{FMMIX2IN}} = 30 \text{ to } 70 \mu\text{V}$	20	30	–	dB
		$V_{\text{FMMIX2IN}} = 70 \text{ to } 500 \mu\text{V}$	30	40	–	dB
		$V_{\text{FMMIX2IN}} = 500 \mu\text{V to } 300 \text{ mV}$	35	45	–	dB
		$V_{\text{FMMIX2IN}} = 300 \text{ mV to } 1 \text{ V}$	30	40	–	dB

New In Car Entertainment car radio tuner IC with Precision Adjacent Channel Suppression (NICE-PACS)

TEA6848H

SYMBOL	PARAMETER	CONDITIONS	MIN.	TYP.	MAX.	UNIT
$V_{o(rms)}$	FM MPX output voltage (RMS value)	$\Delta f = 22.5 \text{ kHz}; f_{mod} = 1 \text{ kHz}; V_{FMMIX2IN} = 20 \mu\text{V to } 1 \text{ V}$	205	230	255	mV
		$\Delta f = 1.5 \text{ kHz}; f_{mod} = 1 \text{ kHz}; V_{FMMIX2IN} = 20 \mu\text{V to } 1 \text{ V};$ weather band mode	150	230	310	mV
$I_{o(max)}$	maximum FM MPX output current		100	–	–	μA
B	bandwidth FM MPX output	$C_L = 0; R_L > 20 \text{ k}\Omega$	200	–	–	kHz
PSRR	power supply ripple rejection	$f_{ripple} = 100 \text{ Hz to } 20 \text{ kHz}$	–	40	–	dB
R_L	load resistance		20	–	–	$\text{k}\Omega$
R_o	output resistance		–	–	500	Ω
C_L	load capacitance		–	–	50	pF
t_{sw}	AM to FM switching time	$V_{FMMIX2IN} = 100 \mu\text{V}$	–	100	150	ms
MPX mute						
α_{mute}	muting depth	data byte 2: bit 7 = 1 (mute)	60	80	–	dB
$V_{offset(DC)}$	DC offset during RDS update mute pin FMMPX $\Delta V = V_{muted} - V_{notmuted}$		–30	–	+30	mV
RDS update: pin TRDSMUTE						
$V_{TRDSMUTE}$	voltage at pin TRDSMUTE	no mute	5.2	5.7	6.2	V
		mute	0.7	1.2	1.7	V
I_{dch}	discharge current	$V_o = 3 \text{ V};$ data byte 2: bit 7 = 1	24	32	38	μA
I_{ch}	charge current	$V_o = 3 \text{ V};$ data byte 2: bit 7 = 0	–38	–32	–24	μA
FM IF LEVEL DETECTOR OUTPUT: PIN $V_{level(AMFM)}$; note 3						
$V_{level(AMFM)}$	DC output voltage	$V_{FMMIX2IN} = 10 \mu\text{V to } 1 \text{ V}$	0	–	7	V
		$V_{FMMIX2IN} < 1 \mu\text{V};$ standard setting of level DAA	0.1	0.35	0.9	V
		$V_{FMMIX2IN} = 1 \text{ mV};$ standard setting of level DAA	1	1.5	2.1	V
$\Delta V_{level(AMFM)}$	step size of starting point adjustment	data byte 5: bit 2 = 1, bit 1 = 0, bit 0 = 0	30	40	50	mV
$V_{level(slope)}$	slope of level voltage $\frac{\Delta V_{level(AMFM)}}{\Delta V_{FMMIX2IN}}$	$V_{FMMIX2IN} = 1 \text{ to } 300 \text{ mV};$ standard setting of level slope	650	800	950	$\frac{\text{mV}}{20 \text{ dB}}$
ΔV_{step}	step size of slope adjustment	$V_{FMMIX2IN} = 1 \text{ mV}$	45	60	75	$\frac{\text{mV}}{20 \text{ dB}}$
$B_{level(AMFM)}$	bandwidth of level output voltage	$V_{FMMIX2IN} = 10 \text{ mV};$ standard setting of level DAA	200	300	–	kHz
I_{source}	output source current		–	–	–300	μA
I_{sink}	output sink current		50	–	–	μA
R_o	output resistance		–	–	500	Ω