



Chipsmall Limited consists of a professional team with an average of over 10 year of expertise in the distribution of electronic components. Based in Hongkong, we have already established firm and mutual-benefit business relationships with customers from,Europe,America and south Asia,supplying obsolete and hard-to-find components to meet their specific needs.

With the principle of “Quality Parts,Customers Priority,Honest Operation,and Considerate Service”,our business mainly focus on the distribution of electronic components. Line cards we deal with include Microchip,ALPS,ROHM,Xilinx,Pulse,ON,Everlight and Freescale. Main products comprise IC,Modules,Potentiometer,IC Socket,Relay,Connector.Our parts cover such applications as commercial,industrial, and automotives areas.

We are looking forward to setting up business relationship with you and hope to provide you with the best service and solution. Let us make a better world for our industry!



## Contact us

Tel: +86-755-8981 8866 Fax: +86-755-8427 6832

Email & Skype: info@chipsmall.com Web: www.chipsmall.com

Address: A1208, Overseas Decoration Building, #122 Zhenhua RD., Futian, Shenzhen, China



# Specifications

**Model No.** TF037C-2100-F

**Issuing Date**

Aug.1, 2017

## 1. Scope

This specification applies to Blower TF037C-2100-F (hereinafter referred to as "the PRODUCT"), a product of NIDEC COPAL ELECTRONICS CORP. (hereinafter referred to as "NCEL").

Reference driving circuit :NCEL's standard driving circuit

## 2. Specification

(Note1) Unless otherwise specified, the environmental conditions are 23°C±5°C, normal humidity, and atmospheric pressure range 90 to 106kPa.

(Note2) Measuring conditions :

Driving circuit = NCEL's standard driving circuit,

Supply voltage = DC24V, measurement equipment = NCEL's standard equipment

(Note3) This specification represents the characteristics at the time of product shipment. Changes in characteristics over time are not covered by this specification.

No.	Items	Specification	Remarks
1	Rated Voltage	DC 24 V±10%	
2	Direction of Rotation	CCW (Counter-Clockwise)	Viewed from top of air inlet.
3	Kind of Gas	Air	Noncorrosive gas
4	Configuration	Motor with Centrifugal Turbo Blade	Driving circuit required separately
5	Type of Motor	DC Brushless Motor	
6	Number of Poles	8 Poles ( 4 pole pairs)	
7	Drive System	3 Phase, Bipolar	
8	Bearings	Aero-Dynamic Bearings	
9	Impeller	Centrifugal Turbo Blade	
10	Outline	Drawing : 6404-00697-00	Attached separately
11	Mounting Direction	Shaft vertical to ground, air inlet facing upward	No vibration, shock, or gyration is to be applied to the product during operation.
12	Rated Rotation Speed	40,000 r/min (reference value)	at 4.0kPa, 100L/min
13	Max. Input Coil Current	3.0 A max. (rms)	Excluding inrush current.
14	Rated Power Supply Current	1.2 A max. (reference value)	at Rated Voltage=DC 24V at 4.0kPa, 100L/min
15	Rated Power Consumption	29 W max. (reference value)	at Rated Voltage=DC 24V at 4.0kPa, 100L/min

No.	Items	Specification	Remarks	
16	Rated Air Flow	100 L/min	at 4.0kPa	
17	Minimum Air Flow	10 L/min		
18	Rated Pressure	4.0 kPa	at 100L/min	
19	Maximum Pressure	4.5 k Pa (absolute maximum pressure)		
20	Torque Constant	0.0026 N·m/A (reference value)		
21	Min. Rotation Speed	10,000 r/min		
22	Acoustic Audible Noise	67.0 dB(A) max. (reference value)	at 4.0kPa, 100L/min Measured at 1m from air inlet Background noise 15dB(A)	
23	Coil Resistance	0.55 Ω (reference value)	at 20°C (Between 2 phase)	
24	Coil Inductance	23 μH (reference value)	at 20°C, 10kHz (Between 2 phase)	
25	Insulation Class	Class E	JIS C 4003	
26	Insulation Resistance	1M ohm min.	DC500V,between terminal pins and plate JIS C 4003	
27	Dielectric Strength	Leak current to be less than 1mA JIS C 4003	AC600V for 1sec. between terminal pins and plate	
28	Weight	94g max. (reference value)		
29	Rotor Inertia	21 g·cm <sup>2</sup> (reference value)		
30	Max. Axial Loading	3 N max.	Max. allowable force to the intake (upper housing) in axial direction.	
31	Operating Temperature Range	0 ~ 50°C		
32	Operating Humidity Range	10 ~ 80%RH	No condensation	
33	Storage Temperature Range	-20 ~ 60°C		
34	Storage Humidity Range	10 ~ 90%RH	No condensation	
35	Resistance to Vibration	Satisfy Spec No.12 ~ 27 after the following test		Non-operating
		Kind of Vibration	Frequency veering	
		Frequency Range	10~22Hz @ amplitude 1mm	
			22~50Hz @ acceleration 19.6m/s <sup>2</sup> (2G)	
Sweep	To-and-fro, approx. 5min.			
Test Time	X, Y, Z directions, 60min. each			
36	Resistance to Shock	Satisfy Spec No.12 ~ 27 after the following test		Non-operating
		Acceleration	294m/s <sup>2</sup> (30G)	
		Pulse Width	6ms	
		Shock Wave	Semi-sinusoidal wave	
Number of Shock	X, Y, Z, directions, once per each direction			

### 3. Interface

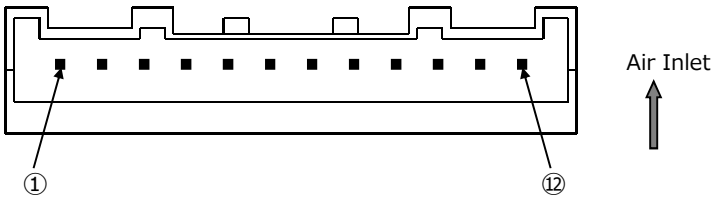

Manufacturer	J.S.T. Mfg. Co., Ltd.
Part No.	SM12B-PASS

**[Mating Connector]**

Manufacturer	J.S.T. Mfg. Co., Ltd.
Part No.	12PAF-6S (insulation displacement (retainer : PAFS-12V-S))
	PAP-12V-S (crimp type) (contact : SPHD-001T-P0.5)

(Note4) Either IDC or crimp type can be used as a mating connector.

Pin No.	Symbol	Signal
1	Vcc	Hall Element Power Supply (+12V)
2	H2-	Hall Element 2 Output
3	H2+	
4	H3-	Hall Element 3 Output
5	H3+	
6	H1-	Hall Element 1 Output
7	H1+	
8	GND	GND
9	TH	Thermistor Output
10	V	Motor Coil (V)
11	W	Motor Coil (W)
12	U	Motor Coil (U)

(Note5) Parts used for thermistor output;  
 Manufacturer : TDK Corp.

Part No. : NTCG164BH103JT

(Note6) Parts used for hall element output;

Manufacturer : Asahi Kasei EMD Corp.

Part No. : HW-105A

### 4. Timing Chart

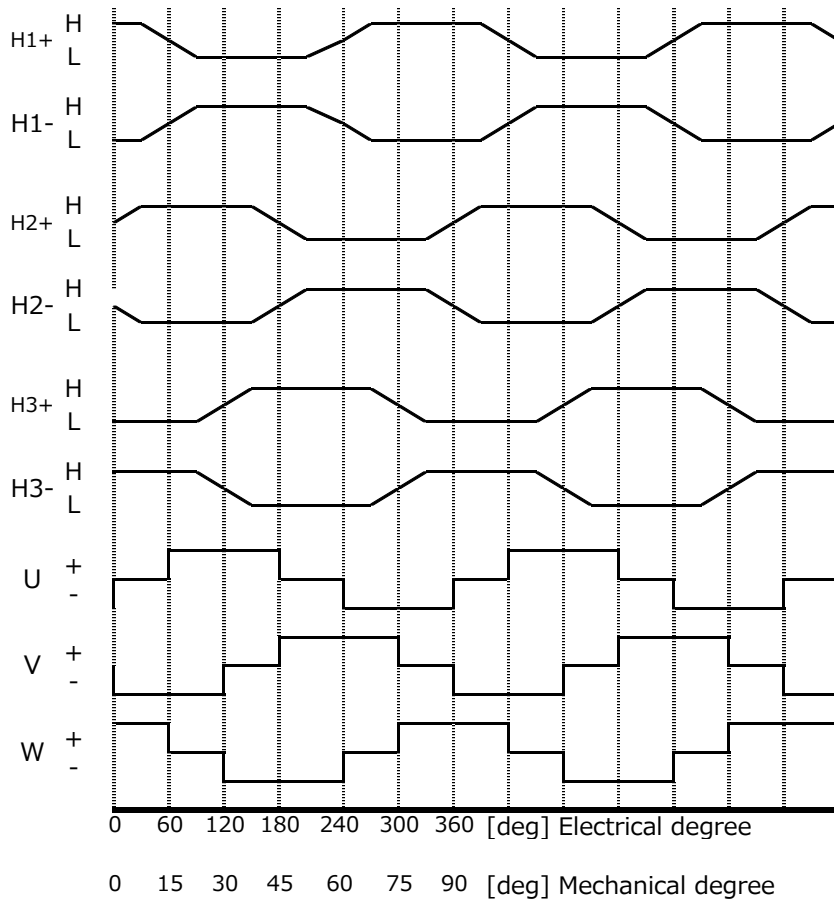

### 5. Operating Range

Conditions: Ambient temperature 23±5°C, normal humidity, atmospheric pressure (100±2kPa).  
Operating range will be discussed separately.

The following graph is provided for reference only. Values are not guaranteed.

#### Operating Range at DC24V

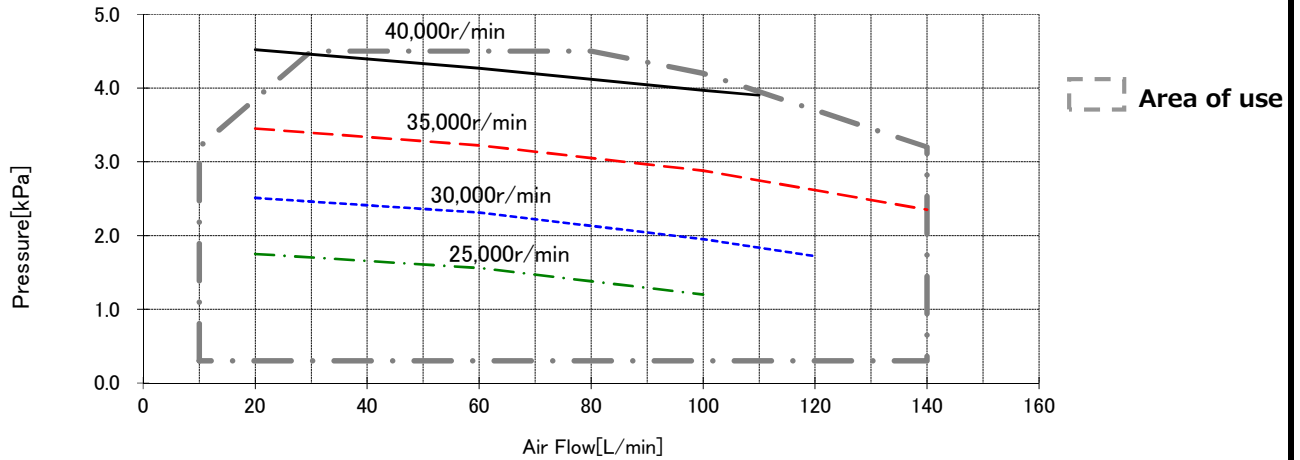

### 6. Manufacturing Code

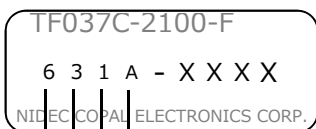

- Control no. : alphabet (A-Z)
- Day of manufacture : refer to Chart 1
- Month of manufacture : refer to Chart 2
- Year of manufacture : last digit of the year (A.D.)

[Chart 1]

Date	1	2	3	4	5	6	7	8	9	10	11	12	13	14	15	16	17	18	19	20
Code	1	2	3	4	5	6	7	8	9	A	B	C	D	E	F	G	H	J	K	L

Date	21	22	23	24	25	26	27	28	29	30	31
Code	M	N	P	Q	R	T	U	V	W	X	Y

[Chart 2]

Month	1	2	3	4	5	6	7	8	9	10	11	12
Code	1	2	3	4	5	6	7	8	9	O	N	D

### 7. Warranty

#### 7-1. Warranty Period

Warranty period of the PRODUCT is 1 year from delivery.

#### 7-2. Warranty Scope

- (1) In case a defect is found in the PRODUCT during the above warranty period and NCEL is responsible for the defect, NCEL will either repair or replace the defected PRODUCT free of charge. However, in the following cases, the PRODUCT will not be covered by warranty.
- ① Defects caused by inappropriate conditions, environments, handlings, and use which are not specified in this specification.
  - ② Defects caused by your equipments and/or software.
  - ③ Defects caused by modifications and/or repairs which were not done by NCEL.
  - ④ Defects which could have been avoided if the PRODUCT was used accordingly to this specification.

- ⑤ Defects which were unpredictable with the scientific or technical level of NCEL at the time of shipment
  - ⑥ Defects caused by external factors such as natural hazards (fire, earthquakes, floods) or electrical
- (2) NCEL will be responsible for the PRODUCT only in which the coverage will be limited to Clause 7-2. (1). NCEL shall not be liable for customer's equipment damages, opportunity losses, or lost earnings caused by defects of the PRODUCTS. The user shall indemnify NCEL and hold NCEL harmless from any liability or damage whatsoever arising out of any action not in accordance with this specification.

### 7-3. Product Application

The PRODUCT is designed and manufactured for general industrial use for general-purposes. Please do not use in applications such as nuclear power, aviations, railroads, or medical equipment where great effect to However,if NCEL agree with the customer the usage of the PRODUCT in such applications, NCEL will warrant the PRODUCT in the same scope described in "7. Warranty" in this specification.

## 8. Notes

- (1) All values are measured with NCEL's standard equipments unless otherwise specified.
- (2) The PRODUCT is compliant with RoHS directives which went into effect July, 2011. Designated hazardous substances are lead, mercury, cadmium, hexavalent chrome, brominated flame retardants (PBB, PBDE) and its compounds.
- (3) The PRODUCT is compliant with Directive 2006/122/EC of the European Parliament (Council Directive 76/769/EEC (30th amendment)) which restricts the use of PFOS.
- (4) Contents of this document may be changed without notice. The production of the PRODUCT may be discontinued without notice. Please confirm with your local contact before ordering.
- (5) Please check if the PRODUCT operates normally at every start-up and during operation.
- (6) Please provide safety measures to prevent damages in case of product failures.
- (7) Performance cannot be guaranteed in case the PRODUCT is used beyond the specification or the PRODUCT is modified.
- (8) Depending on the conditions or the environment, functions or performances of the PRODUCT may not be satisfied when the PRODUCT is used with other equipments.
- (9) Please do not use the PRODUCT in applications to protect the body.
- (10) Please protect the PRODUCT from condensation.
- (11) Please use the correct supply voltage to operate the PRODUCT.
- (12) Do not disassemble or modify the PRODUCT.
- (13) Turn off the power immediately and stop using the PRODUCT in the following cases.
  - In case water or foreign substances get into the PRODUCT.
  - In case the PRODUCT is dropped or the housing is broken.
  - In case unusual odor, abnormal noise, or smoke are generated from the PRODUCT.
- (14) Do not use or store in the following conditions;
  - Humid, dusty, or poorly-ventilated area.
  - Areas where the temperature is expected to rise (direct sunlight, etc.).
  - Areas with corrosive gas or flammable gas in the surrounding air.
  - Areas where vibration, shock, or rocking motion is applied directly to the PRODUCT.
  - Areas where the PRODUCTS may be splashed with water, oil, or chemicals.
  - Areas where static electricity can easily be built up.
- (15) Make sure the wiring is done properly.
- (16) Turn off the power of the PRODUCT and any equipment attached to the PRODUCT when putting on or taking off the cables.
- (17) Install the PRODUCT using cushioning materials such as vibration dampeners. Please contact NCEL if you have any questions regarding installation.
- (18) Do not block the air inlet and outlet (3 places). Please contact NCEL if you have any questions regarding the air inlet and outlet.
- (19) Vibration or audible noise level may change over time due to contamination of the blade. Please provide dust-proof constructions around the PRODUCT.
- (20) Please advise us in case the driving circuit will be designed at the customer's side.

No.	Drawing Number	Name	Qty.	Notes
1				
2				

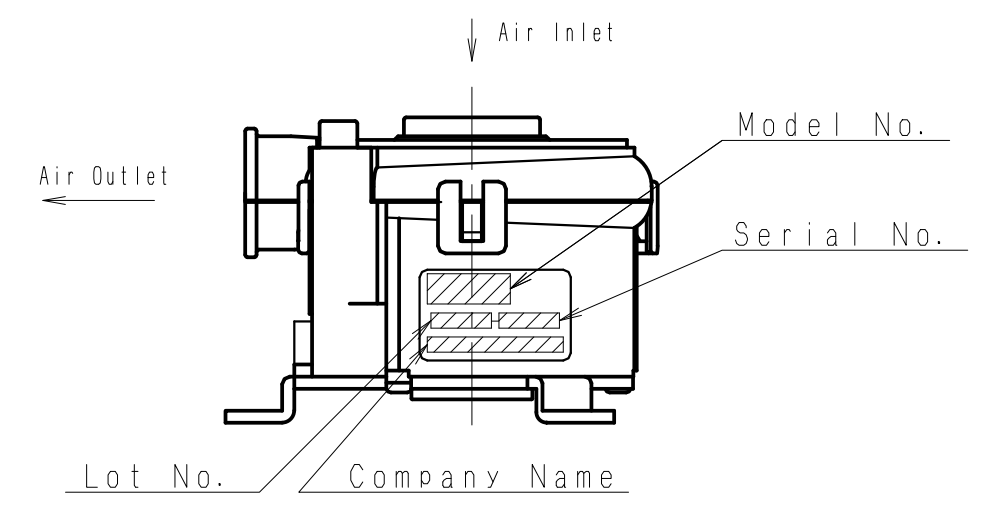
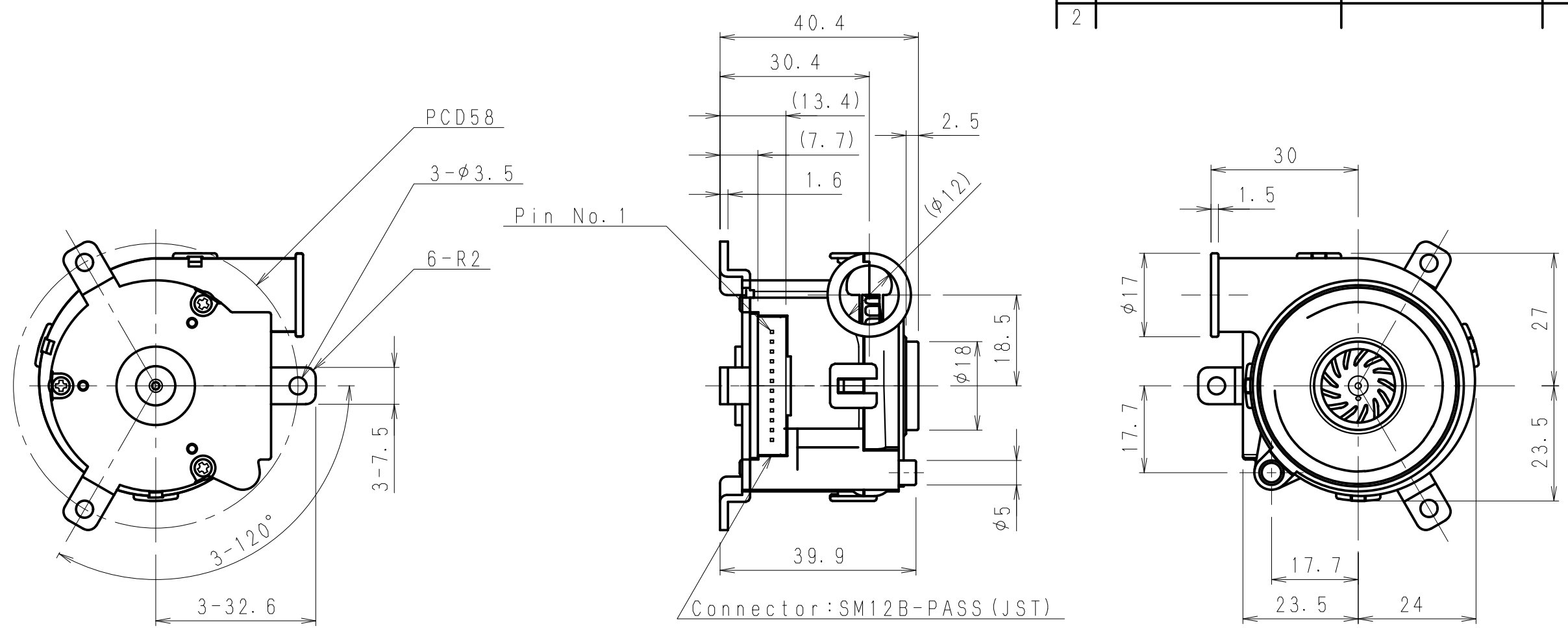

Note  
1. General tolerances. ±0.5.

ISSUED BY DESIGN 3ND GROUP

C. No.	Date	Ecn. No.	Revision	T. S Name	Third Angle Projection Method	Scale	1 : 1	Tolerances	A	B	S	Material	Surface Treatment
..	..	..	..	..	Qty.	1	Finish	-	0 - 30	±0.1	±0.2	±	
..	..	..	..	..	Date	Feb. 16, 2017	Angle Tolerances	±	30 - 120	±0.15	±0.3	±	Model TF037C-2100-F
..	..	..	..	..	Approved by	N. Watanabe	Checked by	Y. Akabane	120 - 315	±0.2	±0.5	±	Heat Treatment
..	..	..	..	..	Designed by	T. Sakai			315 - 1000	±0.3	±0.8	±	Name Blowers Outline
..	..	..	..	..									Dwg. No. 6404-00697-00
												<b>NIDEC COPAL ELECTRONICS CORP.</b>	