



Chipsmall Limited consists of a professional team with an average of over 10 year of expertise in the distribution of electronic components. Based in Hongkong, we have already established firm and mutual-benefit business relationships with customers from,Europe,America and south Asia,supplying obsolete and hard-to-find components to meet their specific needs.

With the principle of “Quality Parts,Customers Priority,Honest Operation,and Considerate Service”,our business mainly focus on the distribution of electronic components. Line cards we deal with include Microchip,ALPS,ROHM,Xilinx,Pulse,ON,Everlight and Freescale. Main products comprise IC,Modules,Potentiometer,IC Socket,Relay,Connector.Our parts cover such applications as commercial,industrial, and automotives areas.

We are looking forward to setting up business relationship with you and hope to provide you with the best service and solution. Let us make a better world for our industry!



Contact us

Tel: +86-755-8981 8866 Fax: +86-755-8427 6832

Email & Skype: info@chipsmall.com Web: www.chipsmall.com

Address: A1208, Overseas Decoration Building, #122 Zhenhua RD., Futian, Shenzhen, China



TFA9843AJ

20 W stereo power amplifier with volume control

Rev. 01 — 28 April 2006

Preliminary data sheet

1. General description

The TFA9843AJ contains two identical audio power amplifiers. The TFA9843AJ can be used as two Single-Ended (SE) channels with a volume control. The maximum gain is 26 dB.

The TFA9843AJ comes in a 9-pin DIL-bent-SIL (DBS9P) power package. The TFA9843AJ is pin compatible with the TFA9842AJ, TFA9843(B)J, TFA9842(B)J and TFA9841J. The difference between the TFA9843AJ and the TFA9843(B)J, TFA9842(B)J, TFA9841J is the functionality of pin 7. The TFA9843AJ has a volume control on pin 7 (VC). The TFA9843(B)J, TFA9842(B)J and TFA9841J have a mode select on pin 7 (MODE).

The TFA9843AJ contains a unique protection circuit that is solely based on multiple temperature measurements inside the chip. This gives maximum output power for all supply voltages and load conditions with no unnecessary audio holes. Almost any supply voltage and load impedance combination can be made as long as thermal boundary conditions (number of channels used, external heatsink and ambient temperature) allow it.

2. Features

- 2 channel SE: 1 W to 20 W operation possibility
- Soft clipping
- Input clamps
- Volume control
- Standby and Mute mode
- No on or off switching plops
- Low standby current
- High supply voltage ripple rejection
- Outputs short-circuit protected to ground, supply and across the load
- Thermally protected
- Pin compatible with the TFA9842AJ, TFA9843(B)J, TFA9842(B)J, TFA9841J

3. Applications

- CRT TV and LCD TV
- Monitors
- PC speakers
- Boom box
- Mini and micro audio receivers

PHILIPS

4. Quick reference data

Table 1. Quick reference data

$V_{CC} = 18\text{ V}$; $T_{amb} = 25\text{ °C}$; $R_L = 4\text{ }\Omega$; $V_{I(VC)} = V_{CC}$; $V_i = 0\text{ V}$; measured in test circuit of [Figure 11](#); unless otherwise specified.

Symbol	Parameter	Conditions	Min	Typ	Max	Unit
V_{CC}	supply voltage	operating	[1] 9	18	28	V
I_q	quiescent current	$V_{CC} = 18\text{ V}$; $R_L = \infty$	-	60	100	mA
$I_{CC(stb)}$	standby supply current	$V_{CC} = 18\text{ V}$; $V_{I(VC)} < 0.8\text{ V}$	-	-	150	μA
P_o	output power	THD = 10 %; $R_L = 4\text{ }\Omega$; $V_{CC} = 18\text{ V}$	7	8.5	-	W
		THD = 10 %; $R_L = 4\text{ }\Omega$; $V_{CC} = 22\text{ V}$	-	14	-	W
THD	total harmonic distortion	$P_o = 1\text{ W}$	-	0.1	0.5	%
$G_{v(max)}$	maximum voltage gain	$V_{I(VC)} > 5.0\text{ V}$	25	26	27	dB
ΔG_v	voltage gain range	$1.5\text{ V} < V_{I(VC)} < 5.0\text{ V}$	-	80	-	dB
SVRR	supply voltage ripple rejection	$f = 1\text{ kHz}$	[2] -	60	-	dB

[1] A minimum load of $3\text{ }\Omega$ is allowed at supply voltages $> 22\text{ V}$.

[2] Supply voltage ripple rejection is measured at the output, with a source impedance $Z_S = 0\text{ }\Omega$ at the input and with a frequency range from 20 Hz to 22 kHz (unweighted). The ripple voltage is a sine wave with a frequency f_{ripple} and an amplitude of 300 mV (RMS), which is applied to the positive supply rail.

5. Ordering information

Table 2. Ordering information

Type number	Package		Version
	Name	Description	
TFA9843AJ	DBS9P	plastic DIL-bent-SIL power package; 9 leads (lead length 12/11 mm); exposed die pad	SOT523 -1

6. Block diagram

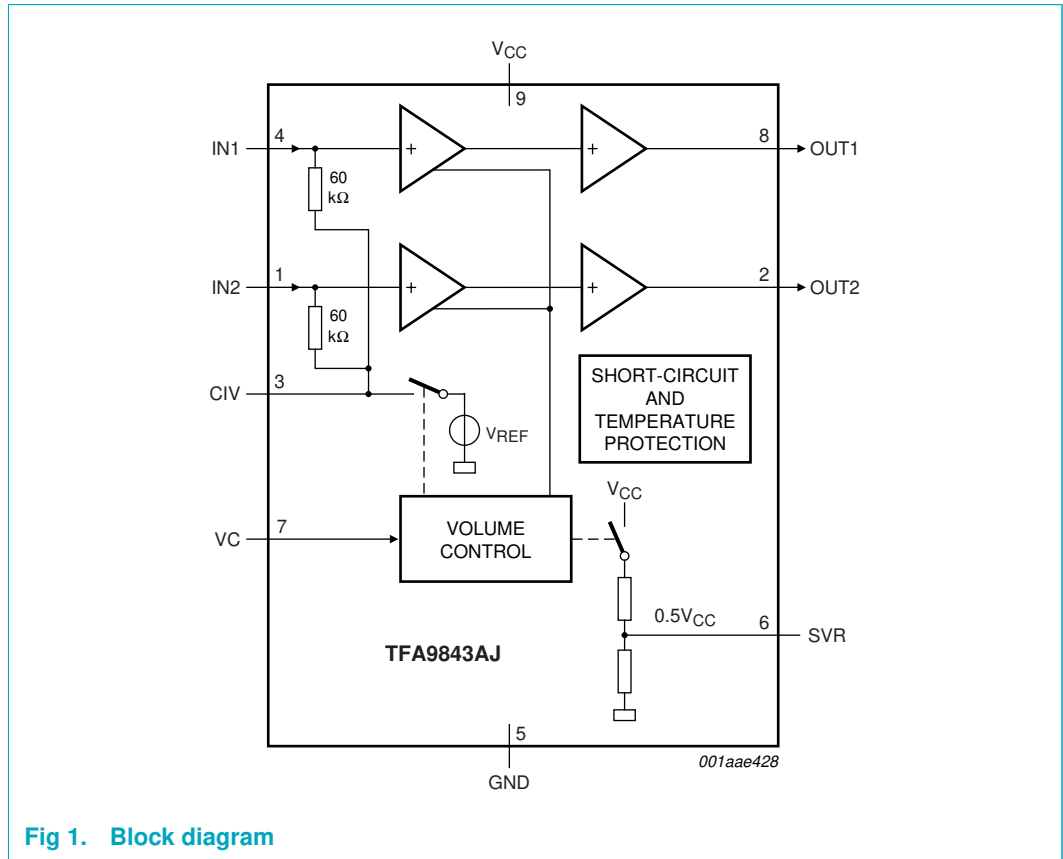

7. Pinning information

7.1 Pinning

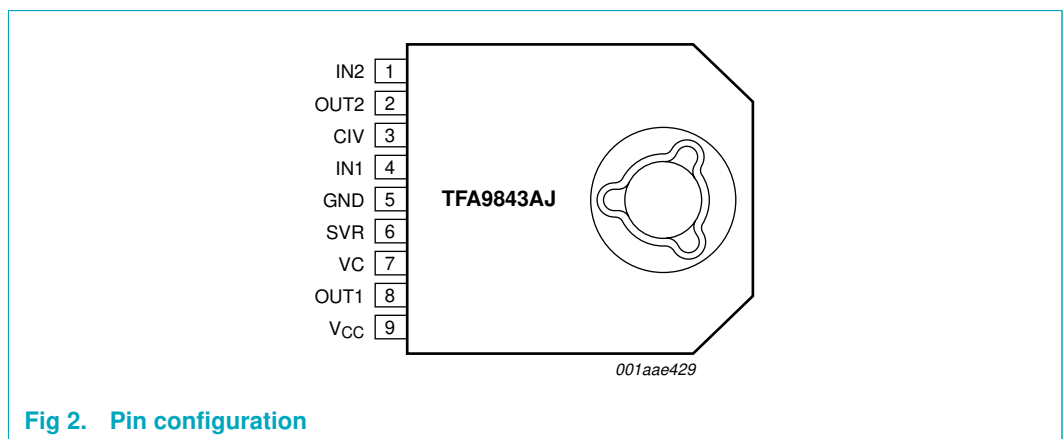

7.2 Pin description

Table 3. Pin description

Symbol	Pin	Description
IN2	1	input 2
OUT2	2	loudspeaker terminal 2
CIV	3	common input voltage decoupling
IN1	4	input 1
GND	5	ground
SVR	6	half supply voltage decoupling (ripple rejection)
VC	7	volume control input (standby, mute and volume control)
OUT1	8	loudspeaker terminal 1
V _{CC}	9	supply voltage

8. Functional description

8.1 Input configuration

The input cut-off frequency is as follows:

$$f_{i(-3dB)} = \frac{1}{2\pi(R_i \times C_i)} \quad (1)$$

Single-ended application: $R_i = 60 \text{ k}\Omega$ and $C_i = 220 \text{ nF}$:

$$f_{i(-3dB)} = \frac{1}{2\pi(60 \times 10^3 \times 220 \times 10^{-9})} = 12 \text{ Hz} \quad (2)$$

As shown in [Equation 2](#), large capacitor values for the inputs are not necessary; therefore switch-on delay during charging of the input capacitors can be minimized. This results in a good low frequency response and good switch-on behavior.

The TFA9843AJ has clamps on the inputs. In Standby mode the voltage on the input pins is clamped for voltages lower than -0.1 V . When the TFA9843AJ is in Mute, Volume control or Operating mode (maximum gain) the input clamp voltage is 1 V (RMS).

8.2 Power amplifier

The power amplifier is a single-ended amplifier with an all NPN output stage, capable of delivering a peak output current of 4 A .

8.2.1 Output power measurement

The output power as a function of the supply voltage is measured on the output pins at $\text{THD} = 10 \%$; see [Figure 7](#). The maximum output power is limited by the supply voltage of 26 V and the maximum available output current is 4 A repetitive peak current. A minimum load of 3Ω is required for supply voltages $> 22 \text{ V}$; see [Figure 4](#). The output power is measured with one channel driven.

8.2.2 Headroom

Typical CD music requires at least 12 dB (factor 15.85) dynamic headroom, compared to the average power output, for transferring the loudest parts without distortion. At $V_{CC} = 18\text{ V}$ and $P_o = 6.5\text{ W}$ (SE with $R_L = 4\ \Omega$) at THD < 0.5 % (see [Figure 5](#)), the Average Listening Level (ALL) music power without any distortion yields:

$$P_{o(ALL, SE)} = \frac{6.5}{15.85} = 410\text{ mW} \quad (3)$$

The power dissipation can be derived from [Figure 8](#) (SE) for 0 dB respectively 12 dB headroom; see [Table 4](#).

For the average listening level a power dissipation of 4.2 W can be used for a heatsink calculation.

Table 4. Power rating as function of headroom

Headroom	Power output (THD < 0.5 %) (SE)	Power dissipation (P); both channels driven
0 dB	$P_o = 6.5\text{ W}$	8.2 W
12 dB	$P_{o(ALL)} = 410\text{ mW}$	4.2 W

8.3 Mode selection

The TFA9843AJ has four functional modes, which can be selected by applying the proper DC voltage to pin VC; see [Table 5](#).

Table 5. Mode selection

$V_{I(VC)}$	Status	Definition
0 V to 0.8 V	Standby	in this mode the current consumption is very low and the outputs are floating; the device is in Standby mode when $V_{I(VC)} < 0.8\text{ V}$
1.2 V to 1.5 V	Mute	in this mode the amplifier is DC-biased but not operational (no audio output); this allows the input coupling capacitors to be charged to avoid pop noise; the device is in Mute mode when $1.2\text{ V} < V_{I(VC)} < 1.5\text{ V}$
1.5 V to 5.0 V	Volume control	in this mode the volume of the amplifier can be controlled; the gain can be adjusted between the range of $1.5\text{ V} < V_{I(VC)} < 5.0\text{ V}$
5.0 V to V_{CC}	On (maximum gain)	in this mode the amplifier has its maximum gain; the Operating mode is activated at $V_{I(VC)} > 5.0\text{ V}$

8.4 Supply voltage ripple rejection

The supply voltage ripple rejection (SVRR) is measured with an electrolytic capacitor of 150 μF connected to pin SVR with a bandwidth of 20 Hz to 22 kHz. The SVRR as a function of the frequency is illustrated in [Figure 10](#). A larger capacitor value on pin SVR improves the ripple rejection behavior at the lower frequencies.

8.5 Built-in protection circuits

The TFA9843AJ contains two types of temperature sensors; one measures the local temperatures of the power stages and one measures the global chip temperature. At a local temperature of the power stage of approximately 185 °C or a global temperature of approximately 150 °C this detection circuit switches off the power stages for 2 ms. When the outputs are switched off the voltage is measured on the outputs. In the event of a short-circuit to ground or to V_{CC} the device will remain in Protection mode. In all other cases the power stages switch-on automatically and the detection will take place again; however a too high temperature will switch-off the power stages immediately. This can result in repetitive switching during too high junction temperature. This protects the TFA9843AJ against short-circuits to ground, to the supply voltage, across the load and too high chip temperatures.

The protection will only be activated when necessary, so even during a short-circuit condition, a certain amount of (pulsed) current will still flow through the short-circuit (as much as the power stage can handle without exceeding the critical temperature level).

9. Limiting values

Table 6. Limiting values

In accordance with the Absolute Maximum Rating System (IEC 60134).

Symbol	Parameter	Conditions	Min	Max	Unit
V_{CC}	supply voltage	operating	-0.3	+28	V
V_I	input voltage		-0.3	$V_{CC} + 0.3$	V
I_{ORM}	repetitive peak output current		-	4	A
T_{stg}	storage temperature	non-operating	-55	+150	°C
T_{amb}	ambient temperature	operating	-40	+85	°C
P_{tot}	total power dissipation		-	35	W
$V_{CC(sc)}$	short-circuit protection supply voltage		-	26	V

10. Thermal characteristics

Table 7. Thermal characteristics

Symbol	Parameter	Conditions	Value	Unit
$R_{th(j-a)}$	thermal resistance from junction to ambient	in free air	40	K/W
$R_{th(j-c)}$	thermal resistance from junction to case	both channels driven	2.0	K/W

11. Static characteristics

Table 8. Static characteristics

$V_{CC} = 18\text{ V}$; $T_{amb} = 25\text{ °C}$; $R_L = 4\text{ }\Omega$; $V_{I(VC)} = V_{CC}$; $V_i = 0\text{ V}$; measured in test circuit of [Figure 11](#); unless otherwise specified.

Symbol	Parameter	Conditions	Min	Typ	Max	Unit
V_{CC}	supply voltage	operating	[1] 9	18	28	V
I_q	quiescent current	$R_L = \infty$	-	60	100	mA
$I_{CC(stb)}$	standby supply current	$V_{CC} = 18\text{ V}$; $V_{I(VC)} < 0.8\text{ V}$	-	-	150	μA
V_O	output voltage		[2] -	9	-	V
$V_{I(VC)}$	input voltage on pin VC	On mode (maximum gain)	5.0	-	V_{CC}	V
		Volume control mode	1.5	-	5.0	V
		Mute mode	1.2	-	1.5	V
		Standby mode	0	-	0.8	V
$I_{I(VC)}$	input current on pin VC	$0\text{ V} < V_{I(VC)} < V_{CC}$	-	-	20	μA

[1] A minimum load of $3\text{ }\Omega$ is allowed at supply voltages $> 22\text{ V}$.

[2] The DC output voltage with respect to ground is approximately $0.5V_{CC}$.

12. Dynamic characteristics

Table 9. Dynamic characteristics SE

$V_{CC} = 18\text{ V}$; $T_{amb} = 25\text{ °C}$; $R_L = 4\text{ }\Omega$; $f = 1\text{ kHz}$; $V_{I(VC)} = V_{CC}$; measured in test circuit of [Figure 11](#); unless otherwise specified.

Symbol	Parameter	Conditions	Min	Typ	Max	Unit
P_o	output power	THD = 10 %; $R_L = 4\text{ }\Omega$	7	8.5	-	W
		THD = 0.5 %; $R_L = 4\text{ }\Omega$	-	6.5	-	W
		$V_{CC} = 22\text{ V}$; THD = 10 %; $R_L = 4\text{ }\Omega$	-	14	-	W
THD	total harmonic distortion	$P_o = 1\text{ W}$	-	0.1	0.5	%
$G_{V(max)}$	maximum voltage gain	$V_{I(VC)} > 5.0\text{ V}$	25	26	27	dB
ΔG_V	voltage gain range	$1.5\text{ V} < V_{I(VC)} < 5.0\text{ V}$	-	80	-	dB
V_i	input voltage	gain = 0 dB; THD < 1 %	1.0	-	-	V
Z_i	input impedance		40	60	-	k Ω
$V_{n(o)}$	noise output voltage		[1] -	150	-	μV
SVRR	supply voltage ripple rejection	$f_{ripple} = 1\text{ kHz}$	[2] -	60	-	dB
		$f_{ripple} = 100\text{ Hz to } 20\text{ kHz}$	[2] -	60	-	dB
$V_{o(mute)}$	mute output voltage		[3] -	-	150	μV
α_{cs}	channel separation	$Z_S = 0\text{ }\Omega$	50	60	-	dB
$ \Delta G_{V(max)} $	maximum voltage gain difference		-	-	1	dB

- [1] The noise output voltage is measured at the output in a frequency range from 20 Hz to 22 kHz (unweighted), with a source impedance $Z_S = 0 \Omega$ at the input.
- [2] Supply voltage ripple rejection is measured at the output, with a source impedance $Z_S = 0 \Omega$ at the input and with a frequency range from 20 Hz to 22 kHz (unweighted). The ripple voltage is a sine wave with a frequency f_{ripple} and an amplitude of 300 mV (RMS), which is applied to the positive supply rail.
- [3] Output voltage in Mute mode ($V_{I(VC)} = 1.35$ V) and an input voltage of 1 V (RMS) in a bandwidth from 20 Hz to 22 kHz, including noise.

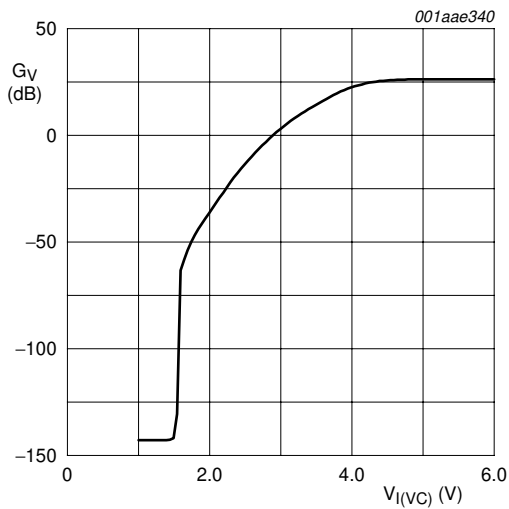

$V_{CC} = 18$ V

Fig 3. Voltage gain as a function of volume control voltage

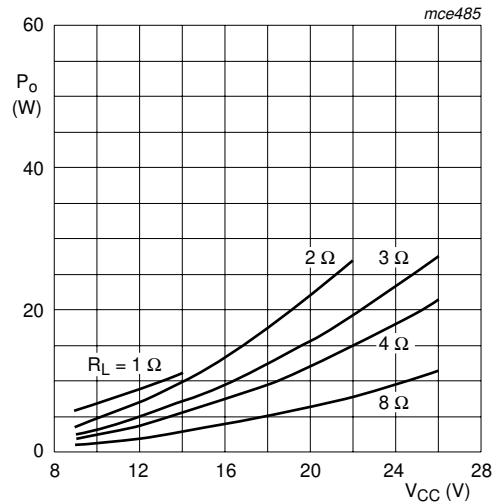

THD = 10 %

Fig 4. Output power (one channel) as a function of supply voltage for various loads

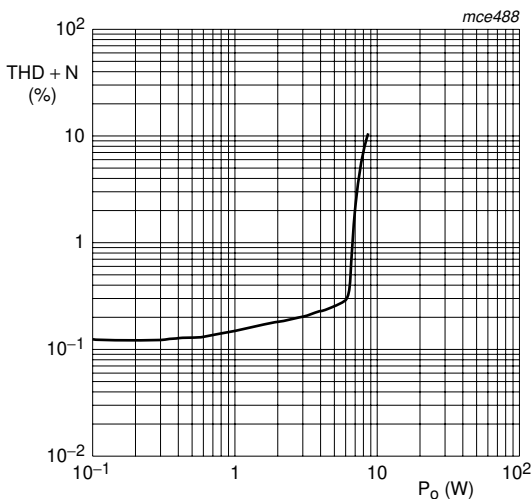

$V_{CC} = 18$ V; $f = 1$ kHz; $R_L = 4 \Omega$

Fig 5. Total harmonic distortion-plus-noise as a function of output power

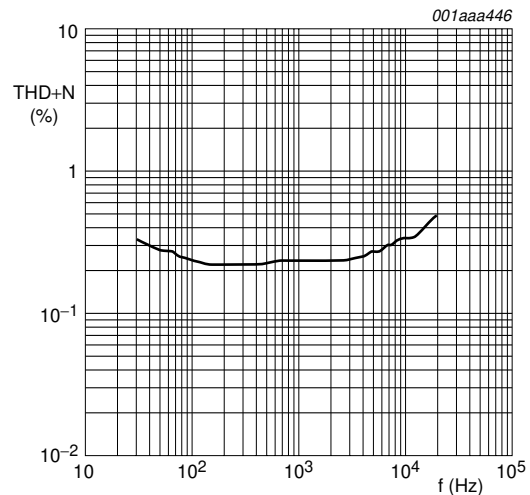

$V_{CC} = 18$ V; $P_o = 1$ W; $R_L = 4 \Omega$

Fig 6. Total harmonic distortion-plus-noise as a function of frequency

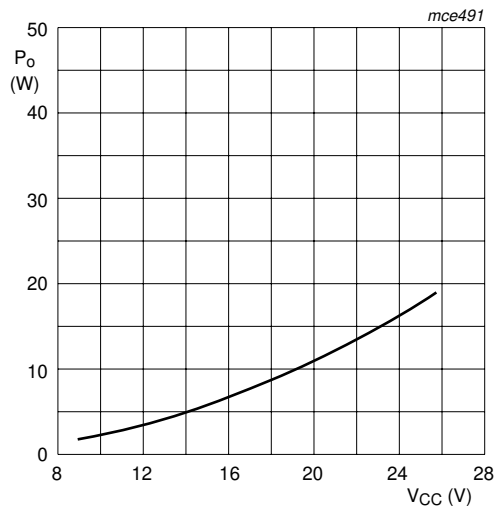

THD = 10 %; $R_L = 4 \Omega$; $f = 1 \text{ kHz}$

Fig 7. Output power as a function of supply voltage

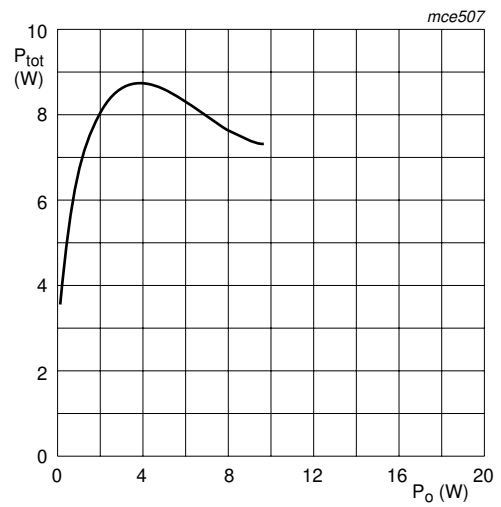

$V_{CC} = 18 \text{ V}$; $R_L = 4 \Omega$

Fig 8. Total power dissipation as a function of channel output power per channel (worst case, both channels driven)

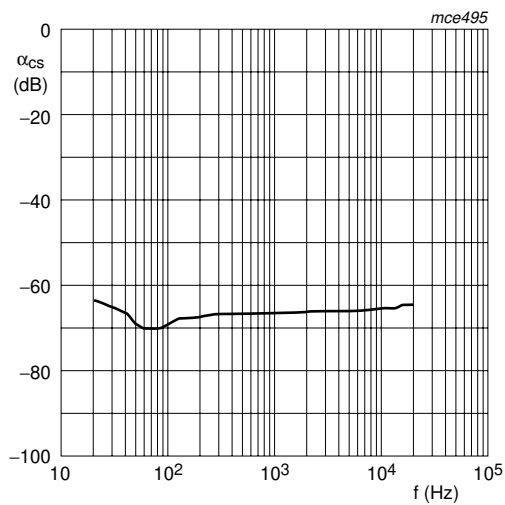

$V_{CC} = 18 \text{ V}$; $R_L = 4 \Omega$

Fig 9. Channel separation as a function of frequency (no bandpass filter applied)

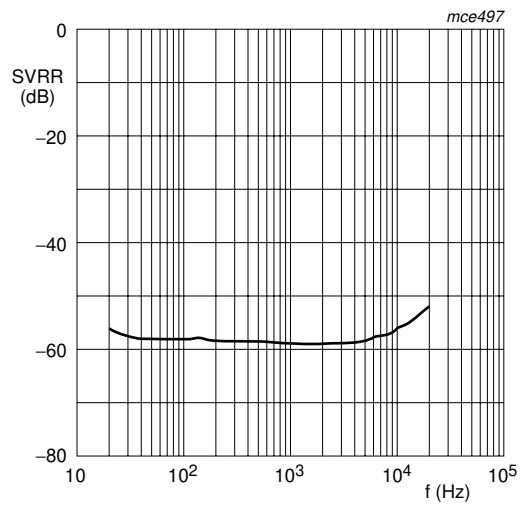

$V_{CC} = 18 \text{ V}$; $Z_S = 0 \Omega$; $V_{\text{ripple}} = 300 \text{ mV (RMS)}$; a bandpass filter of 20 Hz to 22 kHz has been applied; inputs short-circuited.

Fig 10. Supply voltage ripple rejection as a function of frequency

13. Application information

13.1 Application diagrams

13.1.1 Single-ended application

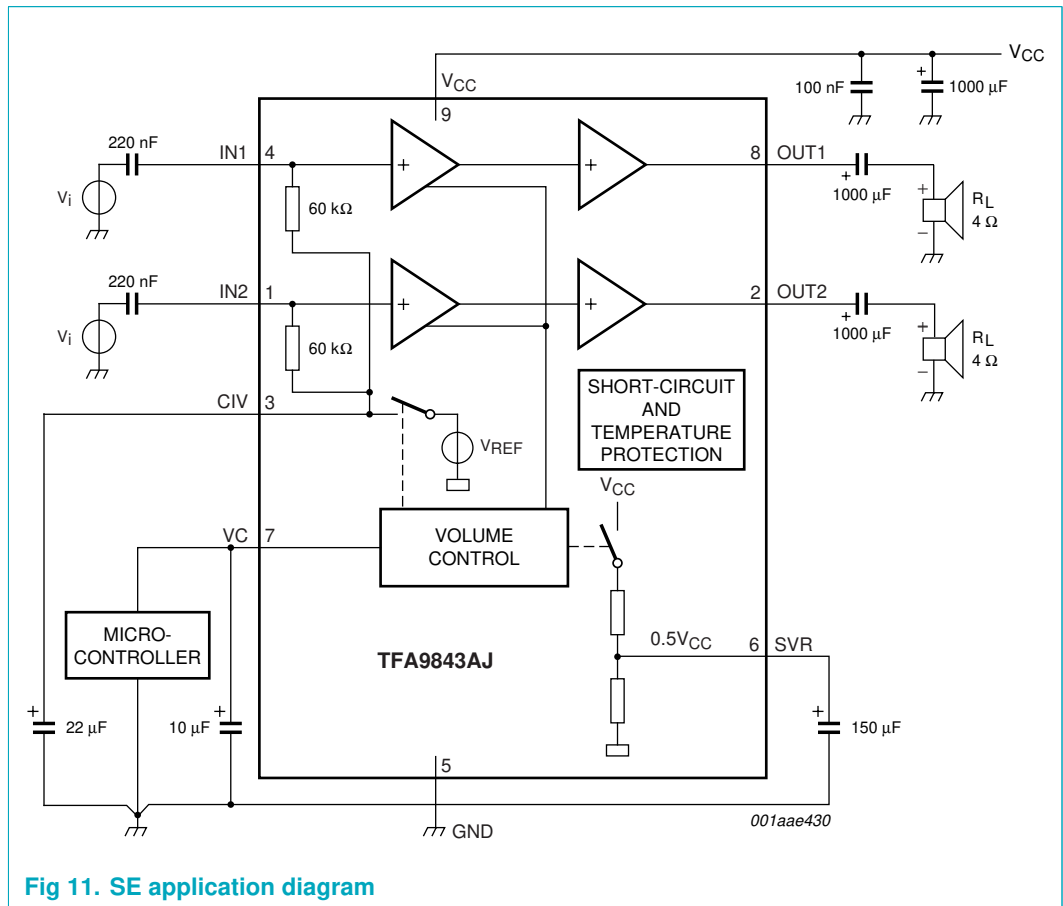

Fig 11. SE application diagram

Remark: By switching inductive loads, the output voltage can rise beyond the maximum supply voltage of 28 V. At high supply voltage it is recommended to use (Schottky) diodes between the supply voltage and ground.

13.1.2 Volume control drive options

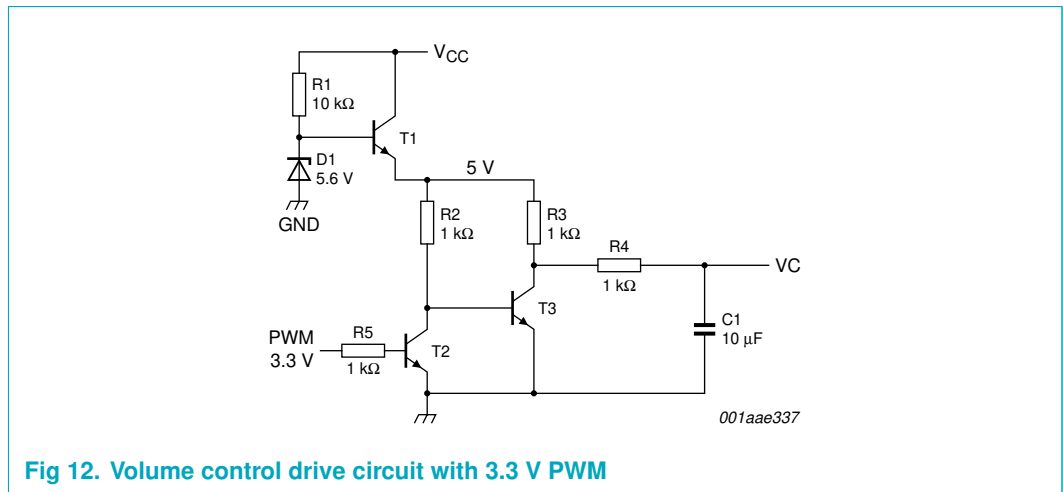

Fig 12. Volume control drive circuit with 3.3 V PWM

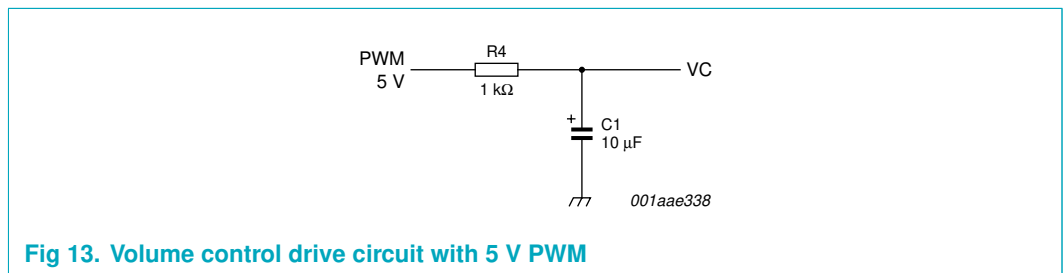

Fig 13. Volume control drive circuit with 5 V PWM

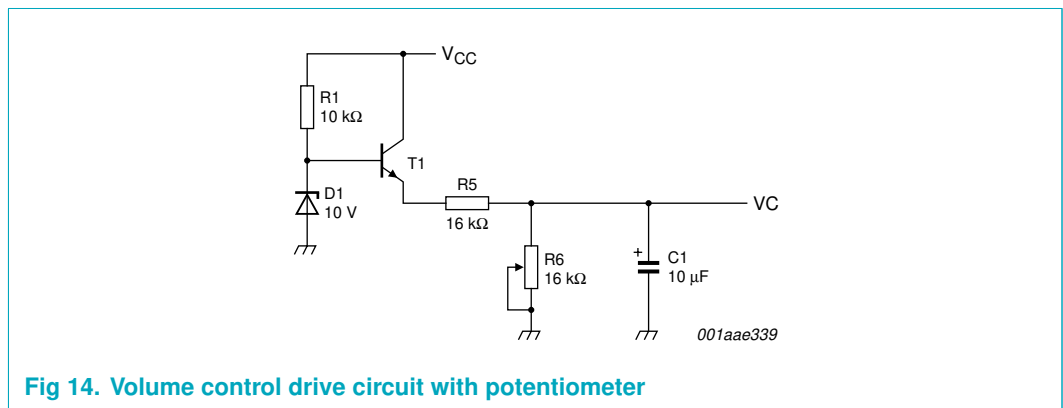

Fig 14. Volume control drive circuit with potentiometer

13.2 Printed-circuit board

13.2.1 Layout and grounding

To obtain a high-level system performance, certain grounding techniques are essential. The input reference grounds have to be tied with their respective source grounds and must have separate tracks from the power ground tracks; this will prevent the large output signal currents from interfering with the small AC input signals. The small-signal ground tracks should be physically located as far as possible from the power ground tracks. Supply and output tracks should be as wide as possible for delivering maximum output power.

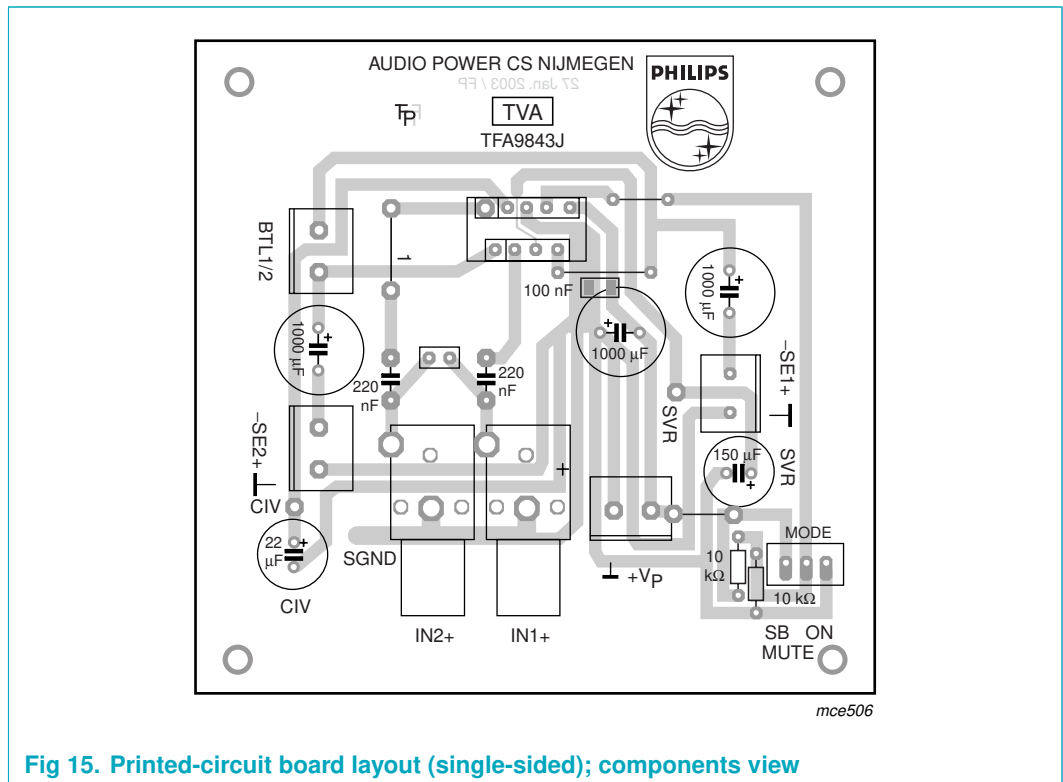

Fig 15. Printed-circuit board layout (single-sided); components view

13.2.2 Power supply decoupling

Proper supply bypassing is critical for low-noise performance and high supply voltage ripple rejection. The respective capacitor location should be as close as possible to the device and connected to the power ground. Proper power supply decoupling also prevents unwanted oscillations.

For suppressing higher frequency transients (spikes) on the supply rail a capacitor with low ESR (typical 100 nF) has to be placed as close as possible to the device. For suppressing lower frequency noise and ripple signals, a large electrolytic capacitor (e.g. 1 000 µF or greater) must be placed close to the device.

The bypass capacitor connected to pin SVR reduces the noise and ripple on the mid rail voltage. For good THD and noise performance, a low ESR capacitor is recommended.

13.3 Thermal behavior and heatsink calculation

The measured maximum thermal resistance of the IC package, $R_{th(j-mb)}$, is 2.0 K/W. A calculation for the heatsink can be made, with the following parameters:

$$T_{amb(max)} = 60 \text{ }^{\circ}\text{C (example)}$$

$$V_{CC} = 18 \text{ V and } R_L = 4 \text{ } \Omega \text{ (SE)}$$

$$T_{j(max)} = 150 \text{ }^{\circ}\text{C (specification)}$$

$R_{th(tot)}$ is the total thermal resistance between the junction and the ambient including the heatsink. This can be calculated using the maximum temperature increase divided by the power dissipation:

$$R_{th(tot)} = (T_{j(max)} - T_{amb(max)})/P$$

At $V_{CC} = 18 \text{ V}$ and $R_L = 4 \text{ } \Omega$ ($2 \times \text{SE}$) the measured worst case sine wave dissipation is 8.4 W; see [Figure 8](#). For $T_{j(max)} = 150 \text{ }^{\circ}\text{C}$ the temperature raise, caused by the power dissipation, is: $150 - 60 = 90 \text{ }^{\circ}\text{C}$:

$$P \times R_{th(tot)} = 90 \text{ }^{\circ}\text{C}$$

$$R_{th(tot)} = 90/8.4 \text{ K/W} = 10.7 \text{ K/W}$$

$$R_{th(h-a)} = R_{th(tot)} - R_{th(j-mb)} = 10.7 \text{ K/W} - 2.0 \text{ K/W} = 8.7 \text{ K/W}$$

This calculation is for an application at worst case (stereo) sine wave output signals. In practice music signals will be applied, which decreases the maximum power dissipation to approximately half of the sine wave power dissipation; see [Section 8.2.2](#). This allows the use of a smaller heatsink:

$$P \times R_{th(tot)} = 90 \text{ }^{\circ}\text{C}$$

$$R_{th(tot)} = 90/4.2 \text{ K/W} = 21.4 \text{ K/W}$$

$$R_{th(h-a)} = R_{th(tot)} - R_{th(j-mb)} = 21.4 \text{ K/W} - 2.0 \text{ K/W} = 19.4 \text{ K/W}$$

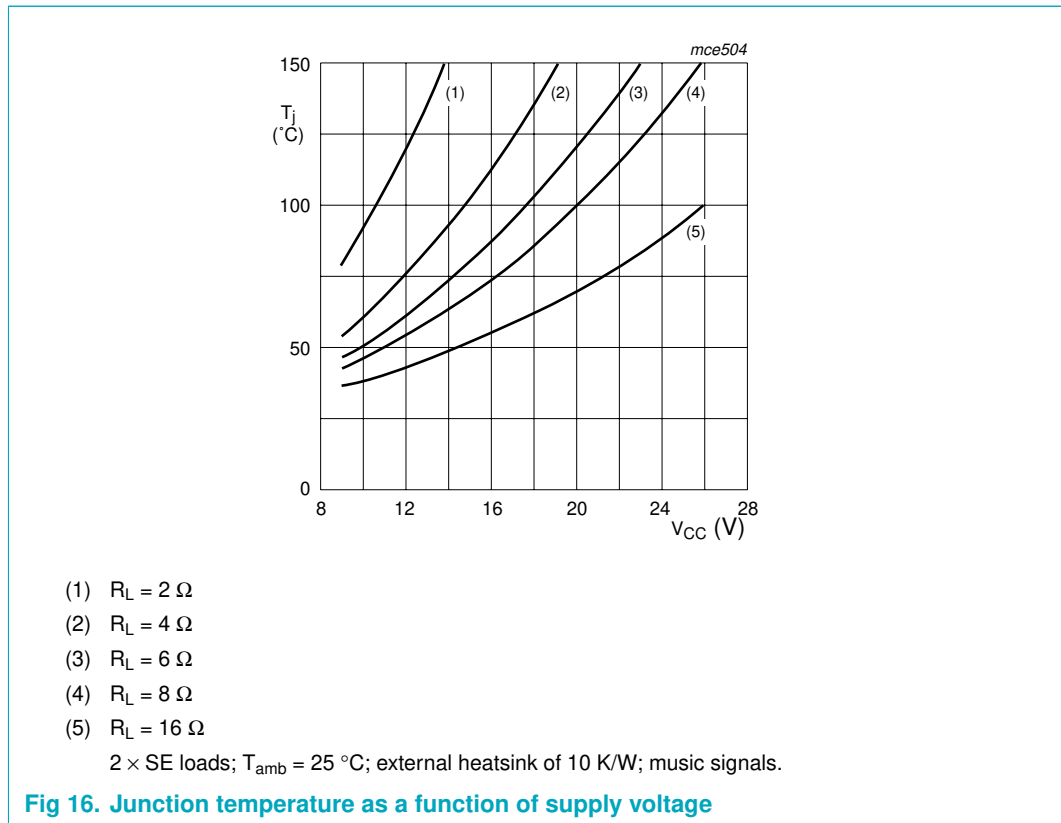

14. Test information

14.1 Quality information

The *General Quality Specification for Integrated Circuits, SNW-FQ-611* is applicable.

15. Package outline

DBS9P: plastic DIL-bent-SIL power package; 9 leads (lead length 12/11 mm); exposed die pad SOT523-1

SOT523-1

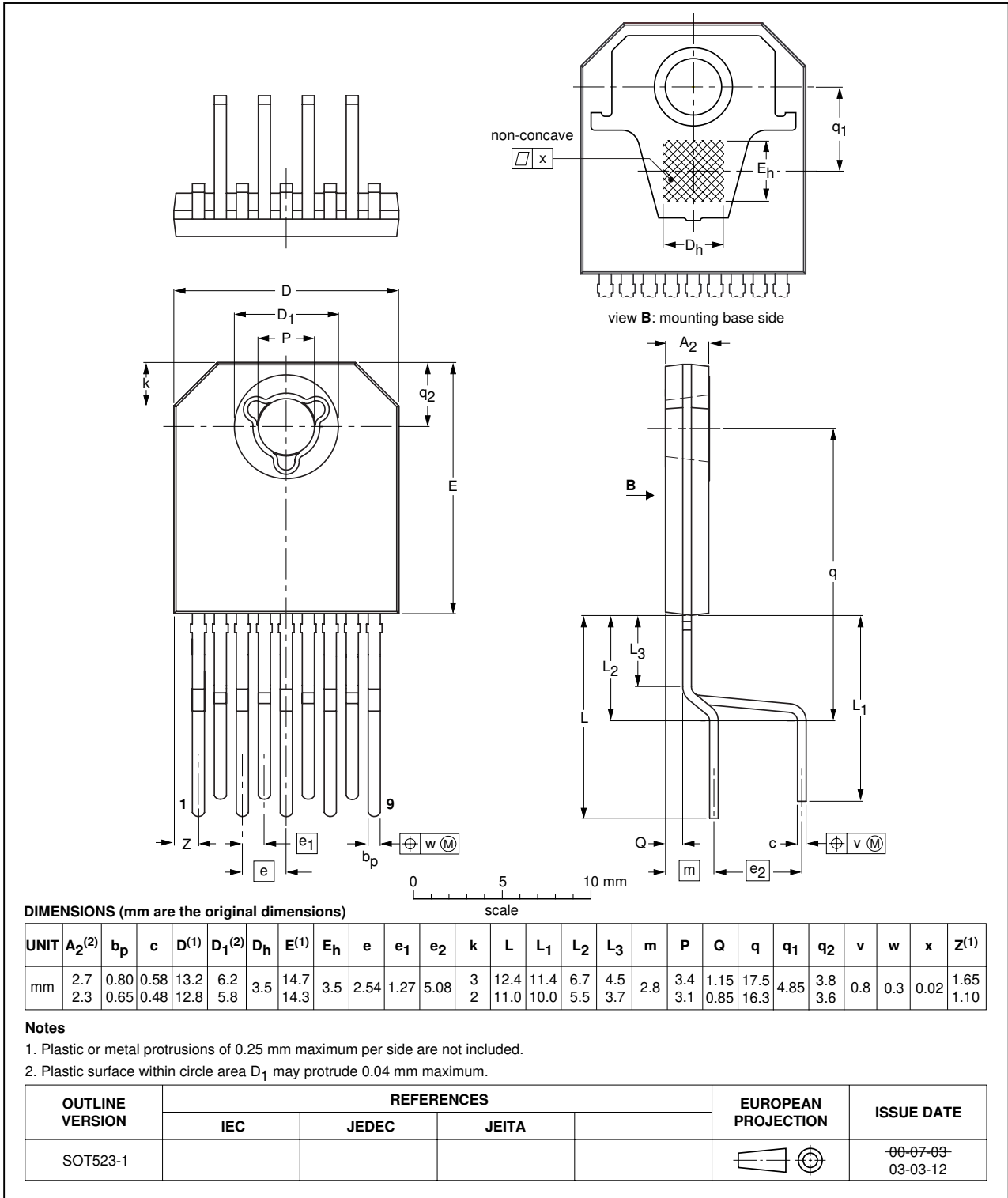

Fig 17. Package outline SOT523-1 (DBS9P)

16. Soldering

16.1 Introduction to soldering through-hole mount packages

This text gives a brief insight to wave, dip and manual soldering. A more in-depth account of soldering ICs can be found in our *Data Handbook IC26; Integrated Circuit Packages* (document order number 9398 652 90011).

Wave soldering is the preferred method for mounting of through-hole mount IC packages on a printed-circuit board.

16.2 Soldering by dipping or by solder wave

Driven by legislation and environmental forces the worldwide use of lead-free solder pastes is increasing. Typical dwell time of the leads in the wave ranges from 3 seconds to 4 seconds at 250 °C or 265 °C, depending on solder material applied, SnPb or Pb-free respectively.

The total contact time of successive solder waves must not exceed 5 seconds.

The device may be mounted up to the seating plane, but the temperature of the plastic body must not exceed the specified maximum storage temperature ($T_{stg(max)}$). If the printed-circuit board has been pre-heated, forced cooling may be necessary immediately after soldering to keep the temperature within the permissible limit.

16.3 Manual soldering

Apply the soldering iron (24 V or less) to the lead(s) of the package, either below the seating plane or not more than 2 mm above it. If the temperature of the soldering iron bit is less than 300 °C it may remain in contact for up to 10 seconds. If the bit temperature is between 300 °C and 400 °C, contact may be up to 5 seconds.

16.4 Package related soldering information

Table 10. Suitability of through-hole mount IC packages for dipping and wave soldering methods

Package	Soldering method	
	Dipping	Wave
CPGA, HCPGA	-	suitable
DBS, DIP, HDIP, RDBS, SDIP, SIL	suitable	suitable ^[1]
PMFP ^[2]	-	not suitable

[1] For SDIP packages, the longitudinal axis must be parallel to the transport direction of the printed-circuit board.

[2] For PMFP packages hot bar soldering or manual soldering is suitable.

17. Revision history

Table 11. Revision history

Document ID	Release date	Data sheet status	Change notice	Supersedes
TFA9843AJ_1	20060428	Preliminary data sheet	-	-

18. Legal information

18.1 Data sheet status

Document status ^{[1][2]}	Product status ^[3]	Definition
Objective [short] data sheet	Development	This document contains data from the objective specification for product development.
Preliminary [short] data sheet	Qualification	This document contains data from the preliminary specification.
Product [short] data sheet	Production	This document contains the product specification.

[1] Please consult the most recently issued document before initiating or completing a design.

[2] The term 'short data sheet' is explained in section "Definitions".

[3] The product status of device(s) described in this document may have changed since this document was published and may differ in case of multiple devices. The latest product status information is available on the Internet at URL <http://www.semiconductors.philips.com>.

18.2 Definitions

Draft — The document is a draft version only. The content is still under internal review and subject to formal approval, which may result in modifications or additions. Philips Semiconductors does not give any representations or warranties as to the accuracy or completeness of information included herein and shall have no liability for the consequences of use of such information.

Short data sheet — A short data sheet is an extract from a full data sheet with the same product type number(s) and title. A short data sheet is intended for quick reference only and should not be relied upon to contain detailed and full information. For detailed and full information see the relevant full data sheet, which is available on request via the local Philips Semiconductors sales office. In case of any inconsistency or conflict with the short data sheet, the full data sheet shall prevail.

18.3 Disclaimers

General — Information in this document is believed to be accurate and reliable. However, Philips Semiconductors does not give any representations or warranties, expressed or implied, as to the accuracy or completeness of such information and shall have no liability for the consequences of use of such information.

Right to make changes — Philips Semiconductors reserves the right to make changes to information published in this document, including without limitation specifications and product descriptions, at any time and without notice. This document supersedes and replaces all information supplied prior to the publication hereof.

Suitability for use — Philips Semiconductors products are not designed, authorized or warranted to be suitable for use in medical, military, aircraft, space or life support equipment, nor in applications where failure or

malfunction of a Philips Semiconductors product can reasonably be expected to result in personal injury, death or severe property or environmental damage. Philips Semiconductors accepts no liability for inclusion and/or use of Philips Semiconductors products in such equipment or applications and therefore such inclusion and/or use is for the customer's own risk.

Applications — Applications that are described herein for any of these products are for illustrative purposes only. Philips Semiconductors makes no representation or warranty that such applications will be suitable for the specified use without further testing or modification.

Limiting values — Stress above one or more limiting values (as defined in the Absolute Maximum Ratings System of IEC 60134) may cause permanent damage to the device. Limiting values are stress ratings only and operation of the device at these or any other conditions above those given in the Characteristics sections of this document is not implied. Exposure to limiting values for extended periods may affect device reliability.

Terms and conditions of sale — Philips Semiconductors products are sold subject to the general terms and conditions of commercial sale, as published at <http://www.semiconductors.philips.com/profile/terms>, including those pertaining to warranty, intellectual property rights infringement and limitation of liability, unless explicitly otherwise agreed to in writing by Philips Semiconductors. In case of any inconsistency or conflict between information in this document and such terms and conditions, the latter will prevail.

No offer to sell or license — Nothing in this document may be interpreted or construed as an offer to sell products that is open for acceptance or the grant, conveyance or implication of any license under any copyrights, patents or other industrial or intellectual property rights.

18.4 Trademarks

Notice: All referenced brands, product names, service names and trademarks are the property of their respective owners.

19. Contact information

For additional information, please visit: <http://www.semiconductors.philips.com>

For sales office addresses, send an email to: sales.addresses@www.semiconductors.philips.com

20. Contents

1	General description	1	19	Contact information	18
2	Features	1	20	Contents	19
3	Applications	1			
4	Quick reference data	2			
5	Ordering information	2			
6	Block diagram	3			
7	Pinning information	3			
7.1	Pinning	3			
7.2	Pin description	4			
8	Functional description	4			
8.1	Input configuration	4			
8.2	Power amplifier	4			
8.2.1	Output power measurement	4			
8.2.2	Headroom	5			
8.3	Mode selection	5			
8.4	Supply voltage ripple rejection	5			
8.5	Built-in protection circuits	6			
9	Limiting values	6			
10	Thermal characteristics	6			
11	Static characteristics	7			
12	Dynamic characteristics	7			
13	Application information	10			
13.1	Application diagrams	10			
13.1.1	Single-ended application	10			
13.1.2	Volume control drive options	11			
13.2	Printed-circuit board	12			
13.2.1	Layout and grounding	12			
13.2.2	Power supply decoupling	12			
13.3	Thermal behavior and heatsink calculation ..	13			
14	Test information	14			
14.1	Quality information	14			
15	Package outline	15			
16	Soldering	16			
16.1	Introduction to soldering through-hole mount packages	16			
16.2	Soldering by dipping or by solder wave	16			
16.3	Manual soldering	16			
16.4	Package related soldering information	16			
17	Revision history	17			
18	Legal information	18			
18.1	Data sheet status	18			
18.2	Definitions	18			
18.3	Disclaimers	18			
18.4	Trademarks	18			

Please be aware that important notices concerning this document and the product(s) described herein, have been included in section 'Legal information'.



© Koninklijke Philips Electronics N.V. 2006. All rights reserved.

For more information, please visit: <http://www.semiconductors.philips.com>.

For sales office addresses, email to: sales.addresses@www.semiconductors.philips.com.

Date of release: 28 April 2006

Document identifier: TFA9843AJ_1