



Chipsmall Limited consists of a professional team with an average of over 10 year of expertise in the distribution of electronic components. Based in Hongkong, we have already established firm and mutual-benefit business relationships with customers from,Europe,America and south Asia,supplying obsolete and hard-to-find components to meet their specific needs.

With the principle of “Quality Parts,Customers Priority,Honest Operation,and Considerate Service”,our business mainly focus on the distribution of electronic components. Line cards we deal with include Microchip,ALPS,ROHM,Xilinx,Pulse,ON,Everlight and Freescale. Main products comprise IC,Modules,Potentiometer,IC Socket,Relay,Connector.Our parts cover such applications as commercial,industrial, and automotives areas.

We are looking forward to setting up business relationship with you and hope to provide you with the best service and solution. Let us make a better world for our industry!



## Contact us

Tel: +86-755-8981 8866 Fax: +86-755-8427 6832

Email & Skype: info@chipsmall.com Web: www.chipsmall.com

Address: A1208, Overseas Decoration Building, #122 Zhenhua RD., Futian, Shenzhen, China



# TFA9882

## 3.4 W I2S input mono class-D audio amplifier

Rev. 2 — 20 April 2011

Product data sheet

### 1. General description

---

The TFA9882 is a mono, filter-free class-D audio amplifier in a 9-bump WLCSP (Wafer Level Chip-Size Package) with a 400  $\mu\text{m}$  pitch.

It receives audio and control settings via an I<sup>2</sup>S digital interface. The Power-down to Operating mode transition is triggered when a clock signal is detected on the bit clock input (BCK). Two devices can be combined to build a stereo application.

In stereo applications, the left or right I<sup>2</sup>S audio stream is selected by connecting the word select signal to, respectively, pin WSL or pin WSR. Mono mixing can be achieved by connecting the word select signal to both WSL and WSR. Switching off the word select signal selects Mute mode.

The device features low RF susceptibility because it has a digital input interface that is insensitive to clock jitter. The second order closed loop architecture used in the TFA9882 provides excellent audio performance and high supply voltage ripple rejection.

### 2. Features and benefits

---

- Small outline WLCSP9 package: 1.27 × 1.49 × 0.6 mm
- Wide supply voltage range (fully operational from 2.5 V to 5.5 V)
- High efficiency (90 %, 4  $\Omega$ /20  $\mu\text{H}$  load) and low power dissipation
- Quiescent power:
  - ◆ 6.5 mW ( $V_{\text{DD}} = 1.8 \text{ V}$ ,  $V_{\text{DDP}} = 3.6 \text{ V}$ , 4  $\Omega$ /20  $\mu\text{H}$  load,  $f_s = 32 \text{ kHz}$ )
  - ◆ 7.65 mW ( $V_{\text{DD}} = 1.8 \text{ V}$ ,  $V_{\text{DDP}} = 3.6 \text{ V}$ , 4  $\Omega$ /20  $\mu\text{H}$  load,  $f_s = 48 \text{ kHz}$ )
- Output power:
  - ◆ 1.4 W into 4  $\Omega$  at 3.6 V supply (THD = 1 %)
  - ◆ 2.7 W into 4  $\Omega$  at 5.0 V supply (THD = 1 %)
  - ◆ 3.4 W into 4  $\Omega$  at 5.0 V supply (THD = 10 %)
- Output noise voltage: 24  $\mu\text{V}$  (A-weighted)
- Signal-to-noise ratio: 103 dB ( $V_{\text{DDP}} = 5 \text{ V}$ , A-weighted)
- Fully short-circuit proof across load and to supply lines
- Current limiting to avoid audio holes
- Thermally protected
- Undervoltage and overvoltage protection
- High-pass filter for DC blocking
- Simplified interface for audio and control settings
- Left/right selection and mono mixing
- Three gain settings: -3 dB, 0 dB and +3 dB



- Output slope setting for EMI reduction
- Clip control for smooth clipping
- Mute mode
- Low RF susceptibility
- Insensitive to input clock jitter
- 'Pop noise' free at all mode transitions
- Short power-up time: 4 ms
- Short power-down time: 5  $\mu$ s
- 1.8 V/3.3 V tolerant digital inputs
- Only two external components required

### 3. Applications

- PDAs
- Mobile phones
- Portable gaming devices
- Portable Navigation Devices (PND)
- Notebooks/netbooks
- Portable media players

### 4. Quick reference data

**Table 1. Quick reference data**

All parameters are guaranteed for  $V_{DDP} = 3.6$  V;  $V_{DDD} = 1.8$  V;  $R_L = 4 \Omega$ [1];  $L_L = 20 \mu$ H[1];  $f_i = 1$  kHz;  $f_s = 48$  kHz;  $T_{amb} = 25$  °C; default settings, unless otherwise specified.

Symbol	Parameter	Conditions	Min	Typ	Max	Unit
$V_{DDP}$	power supply voltage	on pin $V_{DDP}$	2.5	-	5.5	V
$V_{DDD}$	digital supply voltage	on pin $V_{DDD}$	1.65	1.8	1.95	V
$I_{DDP}$	power supply current	Operating mode with load	-	1.5	1.7	mA
		Mute mode	-	1.1	1.25	mA
		Power-down mode	-	0.1	1	$\mu$ A
$I_{DDD}$	digital supply current	Operating mode	-	1.25	1.4	mA
		Mute mode	-	1.1	1.2	mA
		Power-down mode BCK = WS = DATA = 0 V	-	2.5	10	$\mu$ A
$P_{o(RMS)}$	RMS output power	THD + N = 1 %				
		$V_{DDP} = 3.6$ V, $f_i = 100$ Hz	-	1.4	-	W
		$V_{DDP} = 5.0$ V, $f_i = 100$ Hz	-	2.7	-	W
		THD + N = 10 %				
		$V_{DDP} = 3.6$ V, $f_i = 100$ Hz	-	1.75	-	W
	$V_{DDP} = 5.0$ V, $f_i = 100$ Hz	-	3.4	-	W	
$\eta_{po}$	output power efficiency	$P_{o(RMS)} = 1.4$ W	-	90	-	%

[1]  $R_L$  = load resistance;  $L_L$  = load inductance.

## 5. Ordering information

Table 2. Ordering information

Type number	Package		Version
	Name	Description	
TFA9882UK	WLCSP9	wafer level chip-size package; 9 bumps; body 1.49 × 1.27 mm	TFA9882UK

## 6. Block diagram

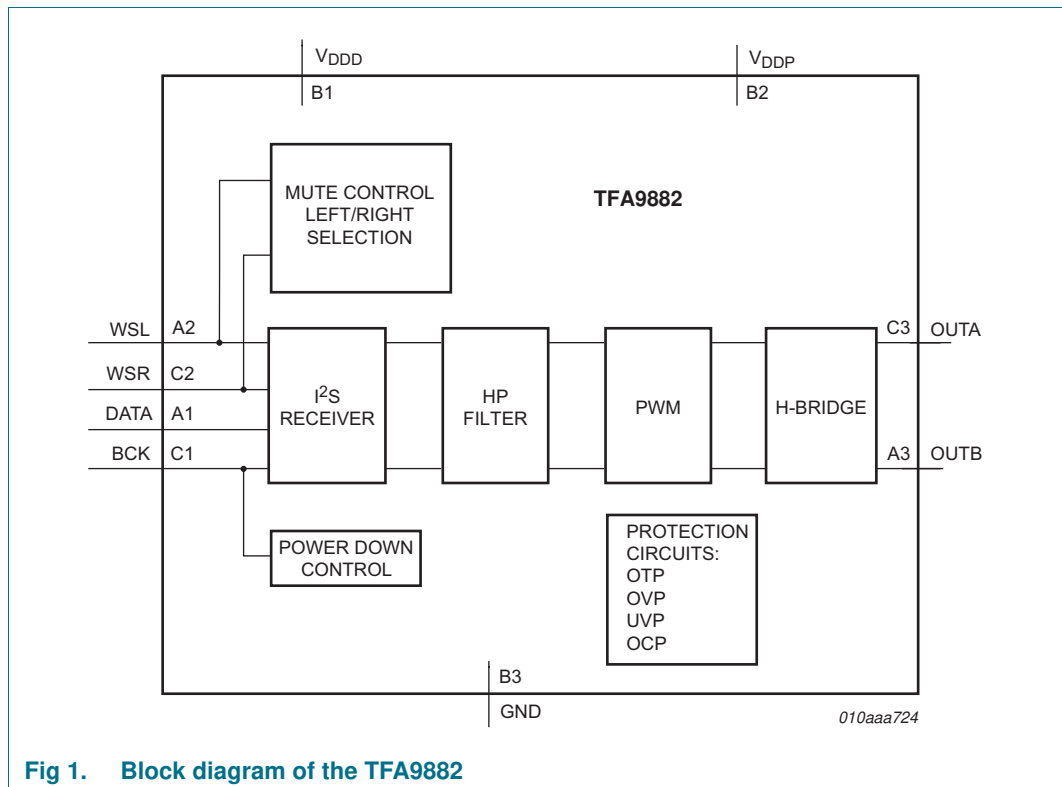
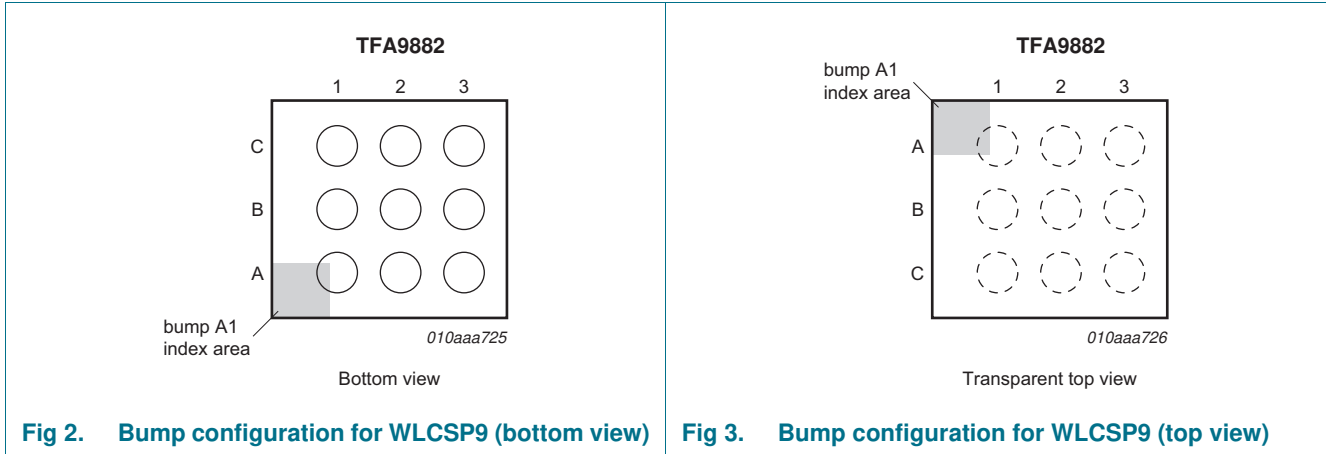

Fig 1. Block diagram of the TFA9882

## 7. Pinning information

### 7.1 Pinning



	1	2	3
A	DATA	WSL	OUTB
B	V <sub>DDD</sub>	V <sub>DDP</sub>	GND
C	BCK	WSR	OUTA

010aaa727  
Transparent top view

Fig 4. Bump mapping for WLCSP9

### 7.2 Pin description

Table 3. Pin description

Symbol	Pin	Type	Description
DATA	A1	I	data input
WSL	A2	I	word select input left channel; connect to V <sub>DDP</sub> or PCB ground if right channel is selected
OUTB	A3	O	inverting output
V <sub>DDD</sub>	B1	P	digital supply voltage (1.8 V)
V <sub>DDP</sub>	B2	P	power supply voltage (2.5 V to 5.5 V)
GND	B3	P	ground reference
BCK	C1	I	bit clock input
WSR	C2	I	word select input right channel; connect to V <sub>DDP</sub> or PCB ground if left channel is selected
OUTA	C3	O	non-inverting output

## 8. Functional description

The TFA9882 is a high-efficiency mono Bridge Tied Load (BTL) class-D audio amplifier with a digital stereo I<sup>2</sup>S input interface. A High-Pass (HP) filter removes the DC components from the incoming I<sup>2</sup>S stream. This stream is subsequently converted into two Pulse Width Modulated (PWM) signals. A 3-level PWM scheme supports filterless speaker drive.

### 8.1 Mode selection and interfacing

The TFA9882 supports four operating modes:

- **Power-down mode**, with low supply current
- **Mute mode**, in which the output stages are floating so that the audio input signal is suppressed
- **Operating mode**, in which the amplifier is fully operational, delivering an output signal
- **Fault mode**

The TFA9882 switches to Fault mode automatically when a protection mechanism is activated (see [Section 8.8](#)). The defined patterns required on the BCK, WSL and WSR inputs to select the other three modes are given in [Table 4](#).

Power-down mode is selected when there is no bit clock signal on the BCK input. Applying the bit clock signal will cause the TFA9882 to switch from Power-down mode to Operating mode (provided the word select signal is switched on).

Mute mode is activated when the word select signal is switched off.

The left or right channel is selected by applying the word select signal to, respectively, the WSL or the WSR terminal. The word select terminal not connected should be connected to V<sub>DDP</sub> or to PCB ground. This simplifies the connection to the V<sub>DDP</sub> terminal in the WLCSP9 package.

When the word select signal is connected to both terminals, the TFA9882 amplifies the sum of both channels divided by two.

**Table 4. Mode selection**

Mode	Channel	Frequency on BCK	Frequency on WSL	Frequency on WSR	OUTA, OUTB
Power-down		0 Hz	don't care	don't care	floating
Mute		2.048 MHz to 3.072 MHz	0 Hz	0 Hz	floating
Operating	left	2.048 MHz to 3.072 MHz	32 kHz to 48 kHz	0 Hz	switching
	right	2.048 MHz to 3.072 MHz	0 Hz	32 kHz to 48 kHz	switching
	(left + right) / 2	2.048 MHz to 3.072 MHz	32 kHz to 48 kHz	32 kHz to 48 kHz	switching

### 8.2 I<sup>2</sup>S format

The TFA9882 supports the Philips I<sup>2</sup>S standard with a BCK frequency 64 times greater than the sampling rate (64f<sub>s</sub>). The bit length can be from 8 to 32 bits. Supported I<sup>2</sup>S sample rates are listed in [Table 5](#) while [Figure 5](#) illustrates the I<sup>2</sup>S data transfer format.

**Table 5. Supported I<sup>2</sup>S sample rates**

f <sub>s</sub> (kHz)	WS (kHz)	BCK, 64f <sub>s</sub> (MHz)
32	32	2.048
44.1	44.1	2.8224
48	48	3.072

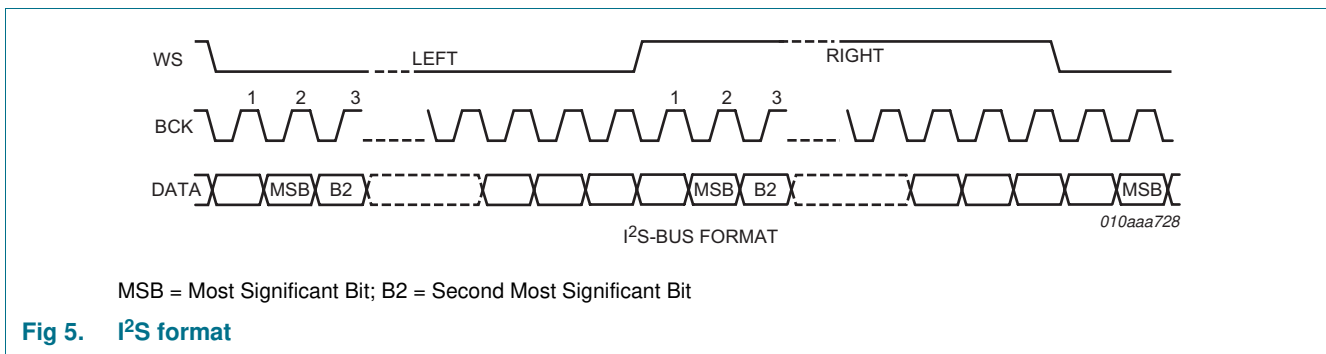

### 8.3 Power-up/power-down sequence

The TFA9882 power-up/power-down sequence is shown in Figure 6. External power supplies V<sub>DDP</sub> and V<sub>DDD</sub> should be within their operating limits before the TFA9882 switches to Operating mode. The TFA9882 should be switched to Power-down mode before the power supplies are disconnected or turned off.

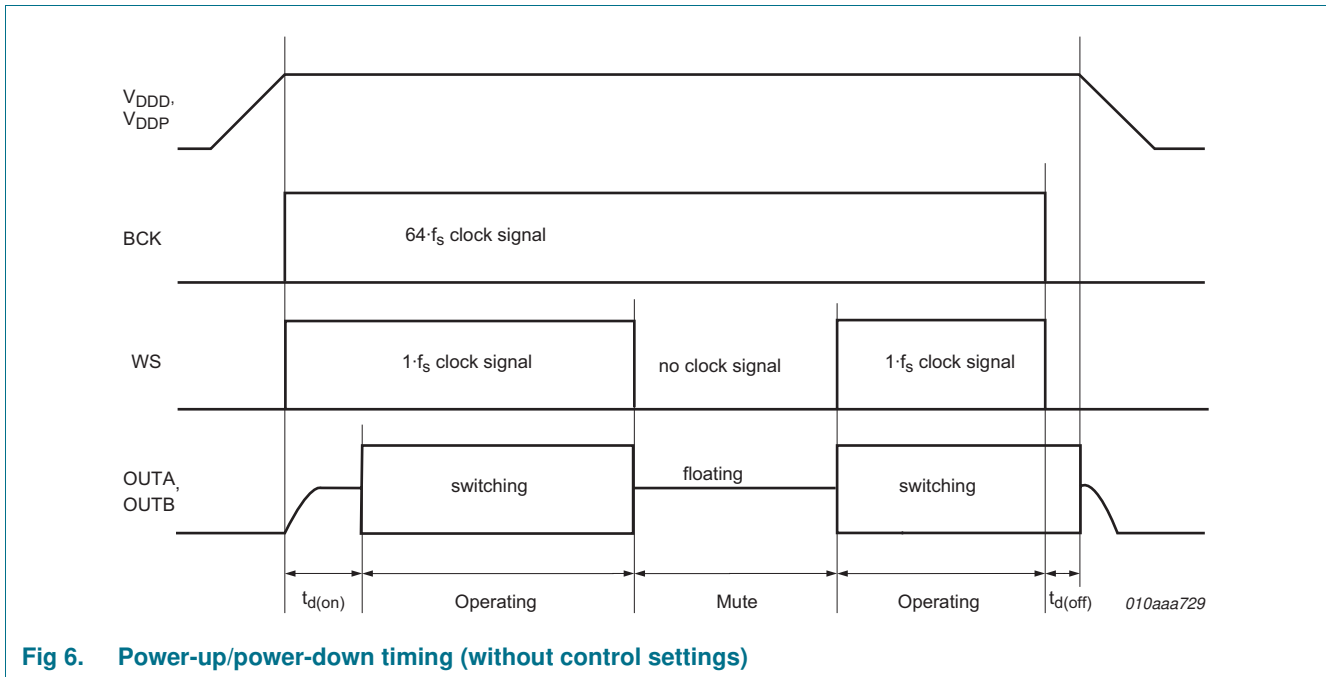

**Table 6. Power-up/power-down timing**

All parameters are guaranteed for  $V_{DDP} = 3.6\text{ V}$ ;  $V_{DDN} = 1.8\text{ V}$ ;  $R_L = 4\ \Omega$ ;  $L_L = 20\ \mu\text{H}$ ;  $f_i = 1\text{ kHz}$ ;  $f_s = 48\text{ kHz}$ ;  $T_{amb} = 25\text{ }^\circ\text{C}$ ; default settings, unless otherwise specified.

Symbol	Parameter	Conditions	Min	Typ	Max	Unit
$t_{d(on)}$	turn-on delay time		[2]	-	4	ms
$t_{d(off)}$	turn-off delay time		[2]	-	5	$\mu\text{s}$

[1]  $R_L$  = load resistance;  $L_L$  = load inductance.

[2] Inversely proportional to  $f_s$ .

## 8.4 Control settings

If the device can operate effectively with the default settings, the control settings don't need to be changed.

### 8.4.1 Control setting pattern recognition

The TFA9882 can detect control settings via the I<sup>2</sup>S input. Control settings are selected by transmitting control patterns on the DATA input during the power-up sequence (the first 12288 bit clock cycles). The word select signal (WS) must be switched off during this interval. Figure 7 illustrates the control setting sequence. After receiving 128 consecutive control setting bytes, the TFA9882 activates the appropriate control setting (see the third column of Table 7). Control settings remain unchanged in all modes unless control pattern 0xAA is received or the V<sub>DD</sub> supply voltage is removed.

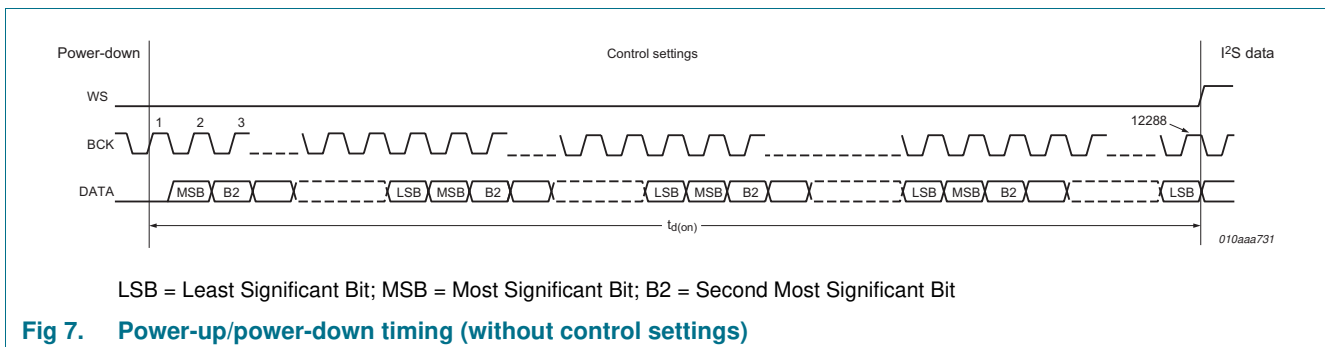

**Fig 7. Power-up/power-down timing (without control settings)**

**Table 7. Control settings**

Byte	Related bytes[1]	Control settings
0xD2	0x69/B4/5A/2D/96/4B/A5	clip control on; see Section 8.4.2
0xD4	0x6A/35/9A/4D/A6/53/A9	gain = -3 dB ( $V_{DDP} = 2.5\text{ V}$ ); see Section 8.4.3
0xD8	0x6C/36/1B/8D/C6/63/B1	gain = +3 dB ( $V_{DDP} = 5.0\text{ V}$ ); see Section 8.4.3
0xE1	0xF0/78/3C/1E/0F/87/C3	slope low (EMC); see Section 8.4.4
0xE2	0x71/B8/5C/2E/17/8B/C5	Dynamic Power Stage Activation (DPSA) off; see Section 8.4.5
0xAA	0x55	Default; no mute, reset settings to default

[1] The related bytes are the bytes from the first column phase shifted by 1, 2, 3, 4, 5, 6 and 7 bits.



**8.4.2 Clip control**

TFA9882 clip control is off by default. Clip control can be turned on via control setting 0xD2 (see [Section 8.4.1](#)). The TFA9882 clips smoothly with clip control on. Output power is at maximum with clip control off.

**8.4.3 Gain selection**

Signal conversion from digital audio to PWM modulated audio out is independent of supply voltages  $V_{DDP}$  and  $V_{DDD}$ . At the default gain setting (0 dB), the audio output signal level is just below the clipping point at a supply voltage of 3.6 V at -6 dBFS (peak) input. The TFA9882 supports two further gain settings to support full output power at  $V_{DDP} = 2.5$  V and  $V_{DDP} = 5.0$  V. The gain settings can be selected via control settings 0xD4 and 0xD8 (see [Section 8.4.1](#)).

[Table 8](#) details the corresponding peak output voltage level at -6 dBFS for the three gain settings.

**Table 8. Output voltage**

All parameters are guaranteed for  $V_{DDP} = 3.6$  V;  $V_{DDD} = 1.8$  V;  $R_L = 4 \Omega$ <sup>[1]</sup>,  $L_L = 20 \mu H$ <sup>[1]</sup>,  $f_i = 1$  kHz,  $f_s = 48$  kHz,  $T_{amb} = 25$  °C, default settings; unless otherwise specified.

Symbol	Parameter	Conditions	Min	Typ	Max	Unit	
$V_{oM}$	peak output voltage	at -6 dBFS (peak) digital input					
		gain = -3 dB, $V_{DDP} = 2.5$ V, $R_L = 4 \Omega$	[1]	-	2.4	-	V
		gain = 0 dB, $V_{DDP} = 3.6$ V, $R_L = 4 \Omega$ ; default	[1]	-	3.4	-	V
		gain = +3 dB, $V_{DDP} = 5.0$ V, $R_L = 8 \Omega$	[1]	-	4.7	-	V

[1]  $R_L$  = load resistance;  $L_L$  = load inductance.

**8.4.4 PWM slope selection**

The rise and fall times of the PWM output edges can be set to one of two values, as detailed in [Table 9](#). The default setting is 'slope normal' (10 ns with  $V_{DDP} = 3.6$  V). 'Slope low' is selected via control setting 0xE1 (see [Section 8.4.1](#)). This function is implemented to reduce ElectroMagnetic Interference (EMI).

**Table 9. Slope rise and fall times**

Setting	Rise and fall times of the PWM output edges
slope low	40 ns with $V_{DDP} = 3.6$ V
slope normal; default setting	10 ns with $V_{DDP} = 3.6$ V

**8.4.5 Dynamic Power Stage Activation (DPSA)**

The TFA9882 uses DPSA to regulate current consumption in line with the level of the incoming audio stream. This function switches off power stage sections that are not needed, reducing current consumption.

Each of the TFA9882 H-bridge power stages is divided into eight sections. The number of power stage sections activated depends on the level of the incoming audio stream. The thresholds used by the DPSA to determine how many stages are switched on are given in [Table 10](#). The DPSA signal is used as a reference signal for switching power stage sections on and off. The DPSA signal will rise in tandem with the rectified audio input signal. When the rectified audio input signal falls, the DPSA decreases with a negative exponential function, as illustrated in [Figure 8](#).

The DPSSA function can be switched off via control setting 0xE2 (see [Section 8.4.1](#)). When DPSSA is off, all power stage sections are activated in Operating mode.

**Table 10. DPSSA input levels**

Setting	Number of power stage sections active
$\leq 0.035 \times \text{full scale (-29 dBFS)}$	1
$> 0.035 \times \text{full scale (-29 dBFS)}$	2
$> 0.07 \times \text{full scale (-23 dBFS)}$	4
$> 0.105 \times \text{full scale (-19.5 dBFS)}$	8

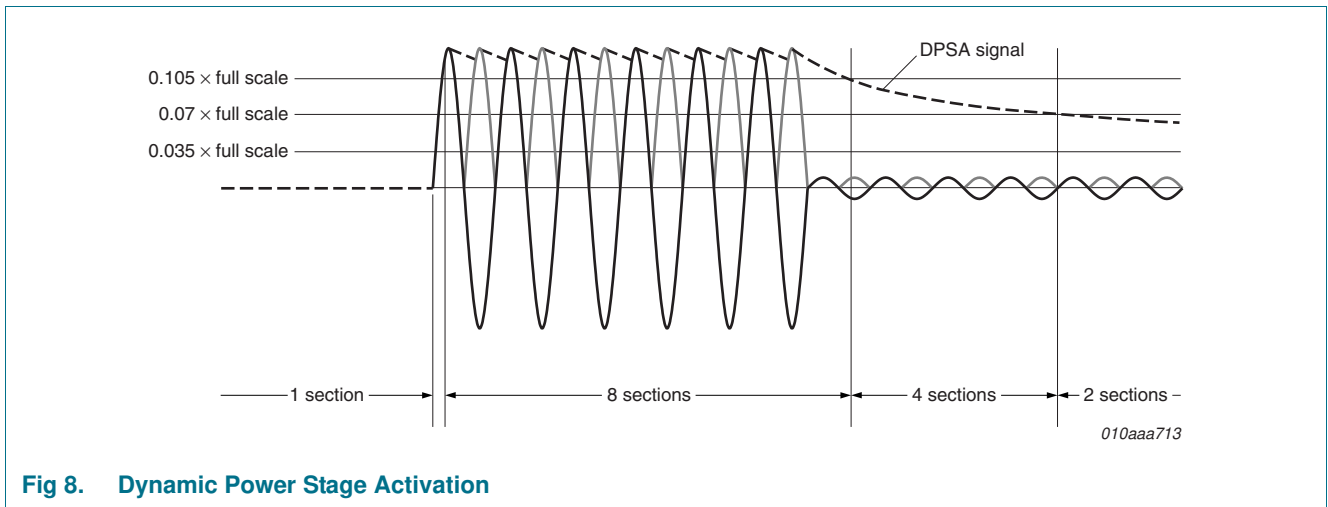

**Fig 8. Dynamic Power Stage Activation**

### 8.5 High-pass filter

The high-pass filter blocks the DC components in the incoming audio stream. The cut-off frequency,  $f_{high(-3dB)}$ , is determined by the sampling frequency,  $f_s$ , and is defined in [Equation 1](#):

$$f_{high(-3dB)} = \frac{-f_s \cdot \ln(4095/4096)}{2 \cdot \pi} \tag{1}$$

$f_{high(-3dB)}$  is about 1.9 Hz at a sampling frequency of 48 kHz. The high-pass filter is always enabled.

### 8.6 PWM frequency

The TFA9882 translates the I2S input stream into an amplified 3-level PWM output signal. The PWM switching frequency is linearly proportional to the sampling frequency, and is defined in [Equation 2](#).

$$f_{sw(PWM)} = 8 \cdot f_s \tag{2}$$

The PWM switching frequency equals 384 kHz when the sampling frequency is 48 kHz.

### 8.7 Bandwidth

The TFA9882 output spectrum has a sigma-delta converter characteristic. [Figure 9](#) illustrates the output power spectrum of the TFA9882 when it is receiving an I<sup>2</sup>S input stream without audio content. The quantization noise is shaped above the band of interest. The band of interest (bandwidth) is determined by the high corner frequency where the noise is increasing. The bandwidth in [Figure 9](#) scales with the sampling frequency and is defined in [Equation 3](#):

$$BW = 0.4535 \cdot f_s \tag{3}$$

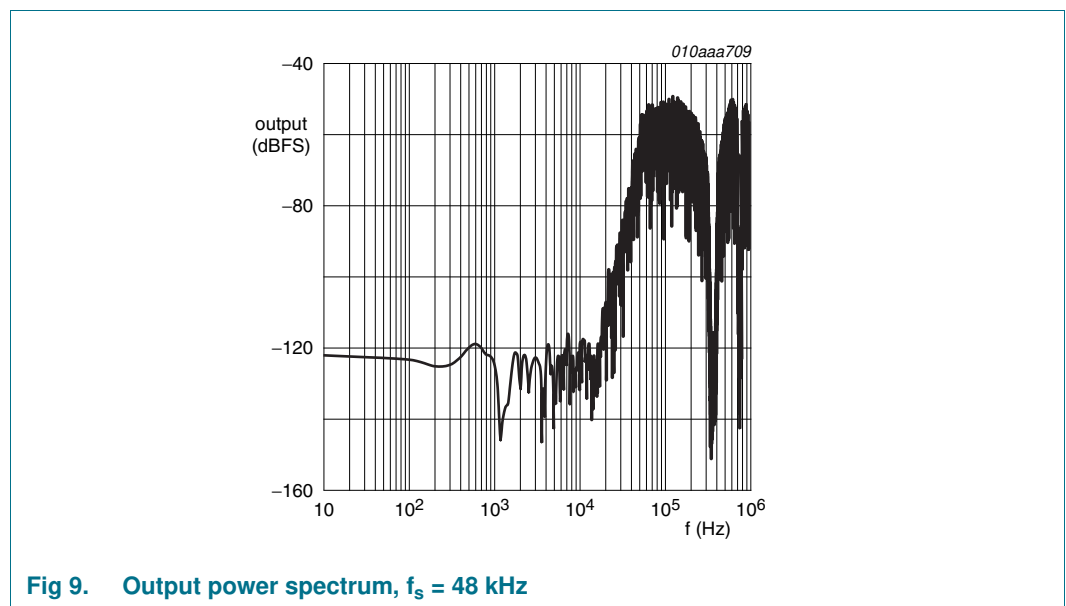

Fig 9. Output power spectrum,  $f_s = 48 \text{ kHz}$

### 8.8 Protection mechanisms

The following protection circuits are included in the TFA9882:

- OverTemperature Protection (OTP)
- OverVoltage Protection (OVP)
- UnderVoltage Protection (UVP)
- OverCurrent Protection (OCP)

The reaction of the device to fault conditions differs depending on the protection circuit involved.

#### 8.8.1 OverTemperature Protection (OTP)

OTP prevents heat damage to the TFA9882. It is triggered when the junction temperature exceeds  $T_{act(th\_prot)}$ . When this happens, the output stages are set floating. OTP is cleared automatically via an internal timer (200 ms), after which the output stages will start to operate normally again.

### 8.8.2 Supply voltage protection mechanisms (UVP and OVP)

UVP is activated, setting the outputs floating, if the supply voltage drops below the undervoltage protection threshold,  $V_{P(UVP)}$ . This transition will be silent, without pop noise. When the supply voltage rises above  $V_{P(UVP)}$  again, the system will be restarted after 200 ms.

OVP is activated, setting the power stages floating, if the supply voltage rises above the overvoltage protection threshold,  $V_{P(OVP)}$ . The power stages are re-enabled as soon as the supply voltage drops below  $V_{P(OVP)}$  again. The system will be restarted after 200 ms.

### 8.8.3 OverCurrent Protection (OCP)

OCP will detect a short circuit across the load or between one of the amplifier outputs and one of the supply lines. If the output current exceeds the overcurrent protection threshold ( $I_{O(OCP)}$ ), it will be limited to  $I_{O(OCP)}$  while the amplifier outputs are switching (the amplifier is not powered down completely). This is called current limiting. The amplifier can distinguish between an impedance drop at the loudspeaker and a low-ohmic short circuit across the load or to one of the supply lines. The impedance threshold depends on which supply voltage is being used:

- In the event of a short circuit across the load or a short to one of the supply lines, the audio amplifier is switched off completely. It will try to restart again after approximately 200 ms. If the short-circuit condition is still present after this time, this cycle will be repeated. Average dissipation will be low because of the short duty cycle.
- In the event of an impedance drop (e.g. due to dynamic behavior of the loudspeaker), the same protection mechanism will be activated. The maximum output current is again limited to  $I_{O(OCP)}$ , but the amplifier will not switch off completely (thus preventing audio holes from occurring). This will result in a clipped output signal without artifacts.

## 9. Internal circuitry

Table 11. Internal circuitry

Pin	Symbol	Equivalent circuit
A1 C1	DATA BCK	<p>010aaa714</p>
B1 B2	V <sub>DDD</sub> V <sub>DDP</sub>	<p>010aaa715</p>
A2 C2	WSL WSR	<p>010aaa716</p>
A3 C3	OUTB OUTA	<p>010aaa717</p>

## 10. Limiting values

Table 12. Limiting values

In accordance with the Absolute Maximum Rating System (IEC 60134).

Symbol	Parameter	Conditions	Min	Max	Unit
V <sub>DDP</sub>	power supply voltage	on pin V <sub>DDP</sub>	-0.3	+5.5	V
V <sub>DDD</sub>	digital supply voltage	on pin V <sub>DDD</sub>	-0.3	+1.95	V
T <sub>j</sub>	junction temperature		-	+150	°C
T <sub>stg</sub>	storage temperature		-55	+150	°C
T <sub>amb</sub>	ambient temperature		-40	+85	°C
V <sub>x</sub>	voltage on pin x	pins BCK and DATA	-0.3	+3.6	V
		pins OUTA and OUTB	-0.6	V <sub>DDP</sub> + 0.6	V
		pins WSL and WSR	-0.6	V <sub>DDP</sub>	V

**Table 12. Limiting values ...continued**

In accordance with the Absolute Maximum Rating System (IEC 60134).

Symbol	Parameter	Conditions	Min	Max	Unit
V <sub>ESD</sub>	electrostatic discharge voltage	according to the Human Body Model (HBM) <a href="#">[1]</a>			
		pins OUTA and OUTB	-8	+8	kV
		any other pin	-2	+2	kV
		according to the Charge Device Model (CDM) <a href="#">[1]</a>	-500	+500	V
		according to the Machine Model (MM) <a href="#">[1]</a>	-200	+200	V

[1] Measurements taken on the TFA9882 in a HVSON10 package (engineering samples) due to handling restrictions with WLCS9.

## 11. Thermal characteristics

**Table 13. Thermal characteristics**

Symbol	Parameter	Conditions	Typ	Unit
R <sub>th(j-a)</sub>	thermal resistance from junction to ambient	in free air; natural convection		
		JEDEC test board <a href="#">[1]</a>	128	K/W
		2-layer application board	97	K/W
Ψ <sub>j-top</sub>	thermal characterization parameter from junction to top of package		<a href="#">[2]</a> 12	K/W

[1] Measured on a JEDEC high K-factor test board (standard EIA/JESD 51-7).

[2] Value depends on where measurement is taken on package.

## 12. Characteristics

### 12.1 DC characteristics

**Table 14. DC characteristics**All parameters are guaranteed for V<sub>DDP</sub> = 3.6 V; V<sub>DDD</sub> = 1.8 V; R<sub>L</sub> = 4 Ω [\[1\]](#); L<sub>L</sub> = 20 μH [\[1\]](#); f<sub>i</sub> = 1 kHz; f<sub>s</sub> = 48 kHz; T<sub>amb</sub> = 25 °C, default slope and gain settings; unless otherwise specified.

Symbol	Parameter	Conditions	Min	Typ	Max	Unit
V <sub>DDP</sub>	power supply voltage	on pin V <sub>DDP</sub>	2.5	-	5.5	V
V <sub>DDD</sub>	digital supply voltage	on pin V <sub>DDD</sub>	1.65	1.8	1.95	V
I <sub>DDP</sub>	power supply current	Operating mode with load				
		f <sub>s</sub> = 48 kHz	-	1.5	1.7	mA
		f <sub>s</sub> = 32 kHz	-	1.38	-	mA
		Mute mode		1.1	1.25	mA
		Power-down mode	-	0.1	1	μA

**Table 14. DC characteristics ...continued**

All parameters are guaranteed for  $V_{DDP} = 3.6\text{ V}$ ;  $V_{DDD} = 1.8\text{ V}$ ;  $R_L = 4\ \Omega$ [1];  $L_L = 20\ \mu\text{H}$ [1];  $f_i = 1\text{ kHz}$ ;  $f_s = 48\text{ kHz}$ ;  $T_{amb} = 25\text{ }^\circ\text{C}$ , default slope and gain settings; unless otherwise specified.

Symbol	Parameter	Conditions	Min	Typ	Max	Unit
$I_{DD}$	digital supply current	Operating mode				
		$f_s = 48\text{ kHz}$	-	1.25	1.4	mA
		$f_s = 32\text{ kHz}$	-	0.85	-	mA
		Mute mode				
		$f_s = 48\text{ kHz}$	-	1.1	1.2	mA
		$f_s = 32\text{ kHz}$	-	0.8	-	mA
		Power-down mode BCK = WS = DATA = 0 V	-	2.5	10	$\mu\text{A}$
<b>Series resistance output power switches</b>						
$R_{DSon}$	drain-source on-state resistance		-	125	150	m $\Omega$
<b>Amplifier output pins; pins OUTA and OUTB</b>						
$ V_{O(\text{offset})} $	output offset voltage		-	-	3	mV
<b>BCK, DATA, WSL and WSR</b>						
$V_{IH}$	HIGH-level input voltage		$0.7V_{DDD}$	-	3.6	V
$V_{IL}$	LOW-level input voltage		-	-	$0.3V_{DDD}$	V
$C_i$	input capacitance		-	-	3	pF
<b>Protection</b>						
$T_{act(th\_prot)}$	thermal protection activation temperature		130	-	150	$^\circ\text{C}$
$V_{P(ovp)}$	overvoltage protection supply voltage		5.5	-	6.0	V
$V_{P(ovp)}$	undervoltage protection supply voltage		2.3	-	2.5	V
$I_{O(ocp)}$	overcurrent protection output current		1.45	-	-	A

[1]  $R_L$  = load resistance;  $L_L$  = load inductance.

## 12.2 AC characteristics

**Table 15. AC characteristics**

All parameters are guaranteed for  $V_{DDP} = 3.6\text{ V}$ ;  $V_{DDD} = 1.8\text{ V}$ ;  $R_L = 4\ \Omega$ <sup>[1]</sup>;  $L_L = 20\ \mu\text{H}$ <sup>[1]</sup>;  $f_i = 1\text{ kHz}$ ;  $f_s = 48\text{ kHz}$ ;  $T_{amb} = 25\text{ }^\circ\text{C}$ , default slope and gain settings; unless otherwise specified.

Symbol	Parameter	Conditions	Min	Typ	Max	Unit
<b>Output power</b>						
$P_{o(RMS)}$	RMS output power	THD + N = 1 %				
		$V_{DDP} = 3.6\text{ V}$ , $f_i = 100\text{ Hz}$	-	1.4	-	W
		$V_{DDP} = 5.0\text{ V}$ , $f_i = 100\text{ Hz}$	-	2.7	-	W
		THD + N = 1 %; $R_L = 8\ \Omega$ ; $L_L = 44\ \mu\text{H}$				
		$V_{DDP} = 3.6\text{ V}$ , $f_i = 100\text{ Hz}$	-	0.75	-	W
		$V_{DDP} = 5.0\text{ V}$ , $f_i = 100\text{ Hz}$	-	1.45	-	W
		THD + N = 10 %				
		$V_{DDP} = 3.6\text{ V}$ , $f_i = 100\text{ Hz}$	-	1.75	-	W
		$V_{DDP} = 5.0\text{ V}$ , $f_i = 100\text{ Hz}$	-	3.4	-	W
$P_{o(RMS)}$	RMS output power	THD + N = 10 %; $R_L = 8\ \Omega$ ; $L_L = 44\ \mu\text{H}$				
		$V_{DDP} = 3.6\text{ V}$ , $f_i = 100\text{ Hz}$	-	0.95	-	W
		$V_{DDP} = 5.0\text{ V}$ , $f_i = 100\text{ Hz}$	-	1.85	-	W
<b>Performance</b>						
$\eta_{po}$	output power efficiency	$P_{o(RMS)} = 1.4\text{ W}$	-	90	-	%
THD+N	total harmonic distortion-plus-noise	$P_{o(RMS)} = 100\text{ mW}$	-	0.02	0.1	%
$V_{n(o)}$	output noise voltage	A-weighted	-	24	-	$\mu\text{V}$
S/N	signal-to-noise ratio	$V_{DDP} = 5\text{ V}$ ; $V_o = 3.4\text{ V (RMS)}$ ; A-weighted	-	103	-	dB
PSRR	power supply rejection ratio	$V_{ripple} = 200\text{ mV}$ ; $f_{ripple} = 217\text{ Hz}$	-	85	-	dB
$V_{oM}$	peak output voltage	at -6 dBFS (peak) digital input:				
		gain = -3 dB; $V_{DDP} = 2.5\text{ V}$	-	2.3	-	V
		gain = 0 dB; $V_{DDP} = 3.6\text{ V}$	3.1	3.3	3.5	V
		gain = +3 dB; $V_{DDP} = 5.0\text{ V}$ ; $R_L = 8\ \Omega$	-	4.7	-	V
<b>Power-up, power-down and propagation times</b>						
$t_{d(on)}$	turn-on delay time		[2]	-	4	ms
$t_{d(off)}$	turn-off delay time		[2]	-	5	$\mu\text{s}$
$t_{PD}$	propagation delay		[2]	-	600	$\mu\text{s}$

[1]  $R_L$  = load resistance;  $L_L$  = load inductance.

[2] Inversely proportional to  $f_s$ .



### 12.3 I<sup>2</sup>S timing characteristics

**Table 16. I<sup>2</sup>S timing characteristics**

All parameters are guaranteed for  $V_{DDP} = 3.6\text{ V}$ ;  $V_{DDD} = 1.8\text{ V}$ ;  $R_L = 4\ \Omega$ <sup>[1]</sup>;  $L_L = 20\ \mu\text{H}$ <sup>[1]</sup>;  $f_i = 1\text{ kHz}$ ;  $f_s = 48\text{ kHz}$ ;  $T_{amb} = 25\text{ }^\circ\text{C}$ , default slope and gain settings; unless otherwise specified.

Symbol	Parameter	Conditions	Min	Typ	Max	Unit
$f_s$	sampling frequency	on pins WSL or WSR	32	-	48	kHz
$f_{clk}$	clock frequency	on pin BCK	-	$64f_s$	-	Hz
$t_{su}$	set-up time	WS edge to BCK HIGH	10	-	-	ns
		DATA edge to BCK HIGH	10	-	-	ns
$t_h$	hold time	BCK HIGH to WS edge	10	-	-	ns
		BCK HIGH to DATA edge	10	-	-	ns

[1]  $R_L$  = load resistance;  $L_L$  = load inductance.

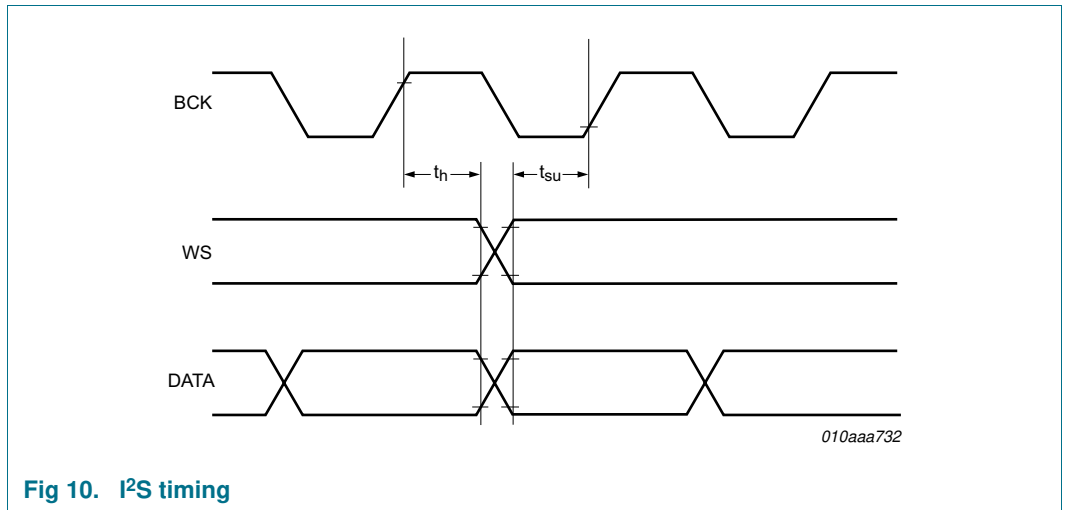

## 13. Application information

### 13.1 ElectroMagnetic Compatibility (EMC)

EMC standards define to what degree a (sub)system is susceptible to externally imposed electromagnetic influences and to what degree a (sub)system is responsible for emitting electromagnetic signals, when in Standby mode or Operating mode.

EMC immunity and emission values are normally measured over a frequency range from 180 kHz up to 3 GHz.

#### 13.1.1 Immunity

A major reason why amplifier devices pick up high frequency signals, and (after detection) manifest these in the device's audio band, is the presence of analog circuits inside the device or in the (sub)system.

The TFA9882 has digital inputs and digital outputs. Comparative tests on a TFA9882-based (sub)system show that the impact of externally imposed electromagnetic signals on the device is negligible in both Standby and Operating modes.

#### 13.1.2 Emissions

Since the TFA9882 is a class-D amplifier with digitally switched outputs in a BTL configuration, it can potentially generate emissions due to the steep edges on the amplifier outputs. External components can be used to suppress these emissions. However, the TFA9882 features built-in slope control to suppress such emissions by reducing the slew rate of the BTL output signals. By reducing the slew rate, the emissions are reduced by some 10 dB when compared with full-speed operation.

### 13.2 Supply decoupling and filtering

A ceramic decoupling capacitor of between 4.7  $\mu\text{F}$  and 10  $\mu\text{F}$  should be placed close to the TFA9882 for decoupling the  $V_{\text{DDP}}$  supply. This minimizes the size of the high-frequency current loop, thereby optimizing EMC performance.

13.3 Typical application diagram (simplified)

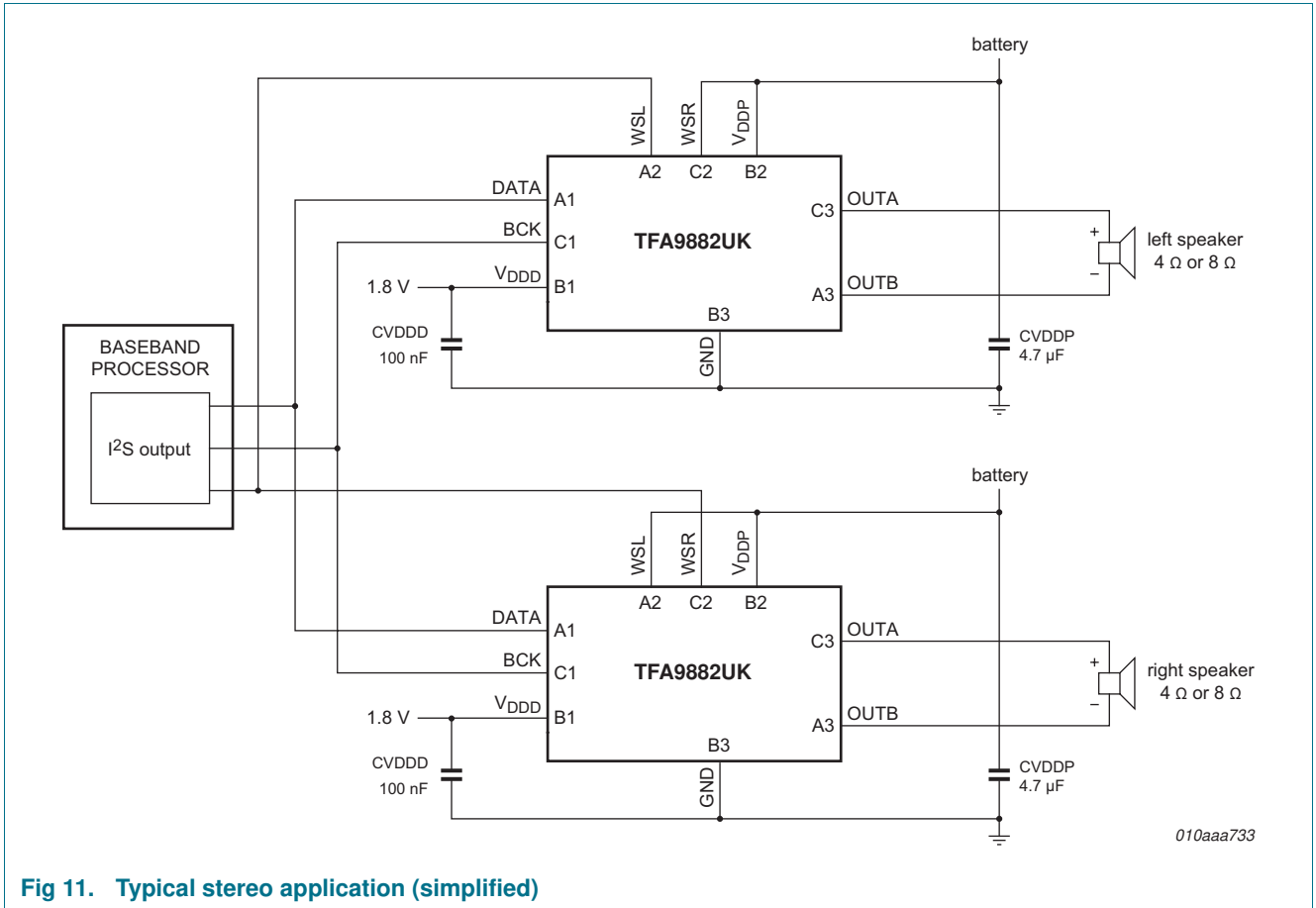
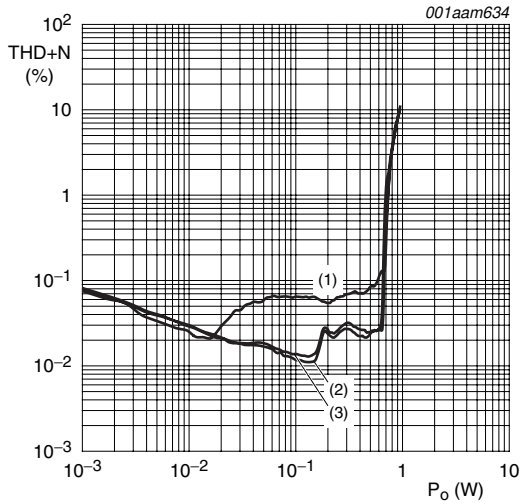

Fig 11. Typical stereo application (simplified)

13.4 Curves measured in reference design (demonstration board)

All measurements were taken with  $V_{DD} = 1.8\text{ V}$ ,  $f_{clk} = 6.144\text{ MHz}$ , clip control off, DPSA off and slope normal, unless otherwise specified.



- (1)  $f_i = 6\text{ kHz}$ .
- (2)  $f_i = 1\text{ kHz}$ .
- (3)  $f_i = 100\text{ Hz}$ .

a.  $V_{DDP} = 3.6\text{ V}$ ,  $R_L = 8\ \Omega$ ,  $L_L = 44\ \mu\text{H}$

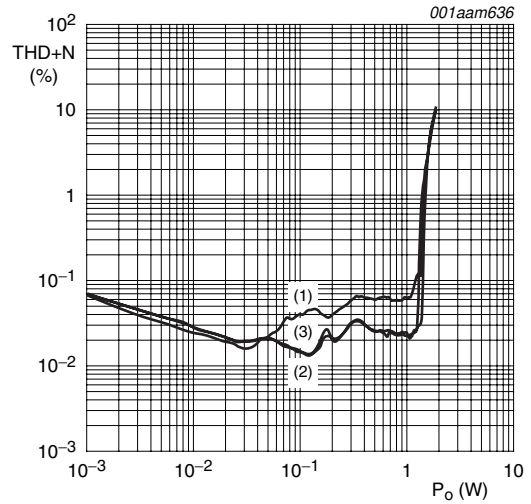

- (1)  $f_i = 6\text{ kHz}$ .
- (2)  $f_i = 1\text{ kHz}$ .
- (3)  $f_i = 100\text{ Hz}$ .

b.  $V_{DDP} = 5\text{ V}$ ,  $R_L = 8\ \Omega$ ,  $L_L = 44\ \mu\text{H}$

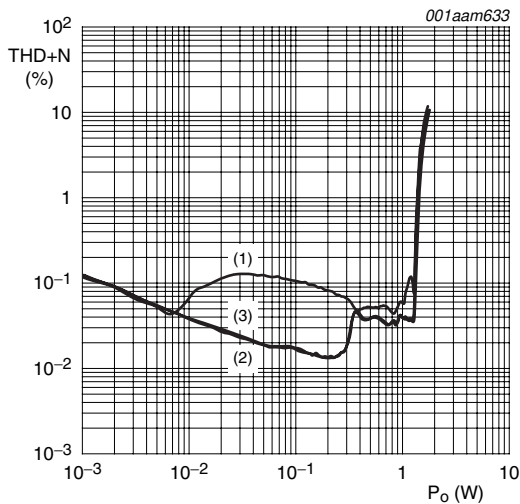

- (1)  $f_i = 6\text{ kHz}$ .
- (2)  $f_i = 1\text{ kHz}$ .
- (3)  $f_i = 100\text{ Hz}$ .

c.  $V_{DDP} = 3.6\text{ V}$ ,  $R_L = 4\ \Omega$ ,  $L_L = 20\ \mu\text{H}$

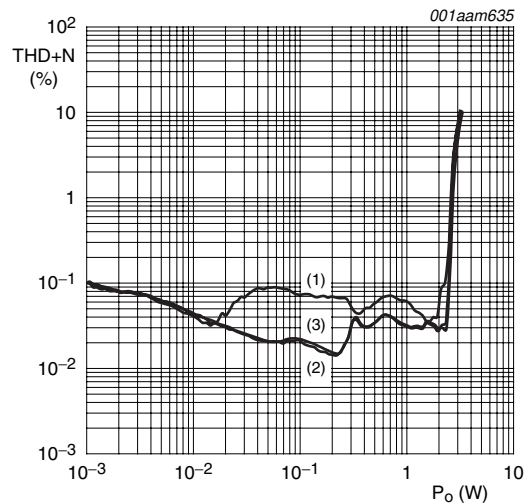

- (1)  $f_i = 6\text{ kHz}$ .
- (2)  $f_i = 1\text{ kHz}$ .
- (3)  $f_i = 100\text{ Hz}$ .

d.  $V_{DDP} = 5\text{ V}$ ,  $R_L = 4\ \Omega$ ,  $L_L = 20\ \mu\text{H}$

Fig 12. THD+N as a function of output power

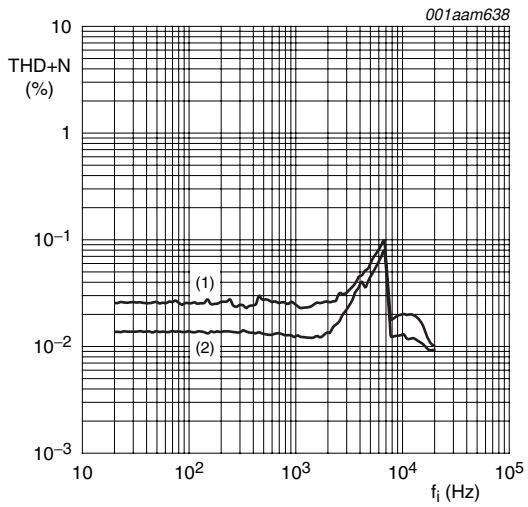

- (1)  $P_o = 500$  mW
- (2)  $P_o = 100$  mW
- a.  $V_{DDP} = 3.6$  V,  $R_L = 8$   $\Omega$ ,  $L_L = 44$   $\mu$ H

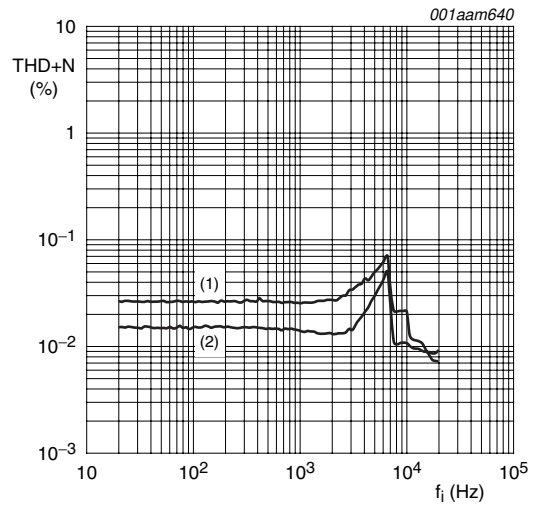

- (1)  $P_o = 500$  mW
- (2)  $P_o = 100$  mW
- b.  $V_{DDP} = 5$  V,  $R_L = 8$   $\Omega$ ,  $L_L = 44$   $\mu$ H

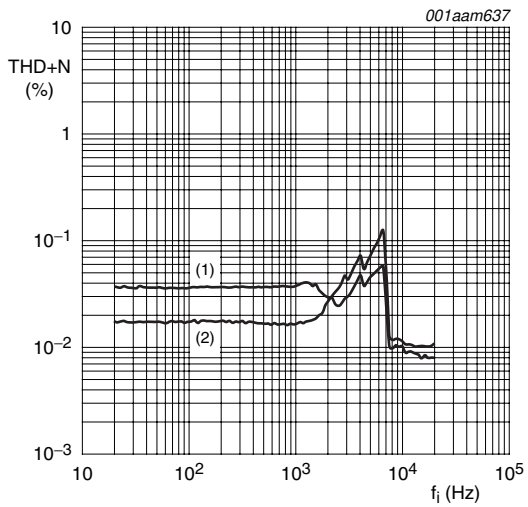

- (1)  $P_o = 1$  W
- (2)  $P_o = 100$  mW
- c.  $V_{DDP} = 3.6$  V,  $R_L = 4$   $\Omega$ ,  $L_L = 20$   $\mu$ H

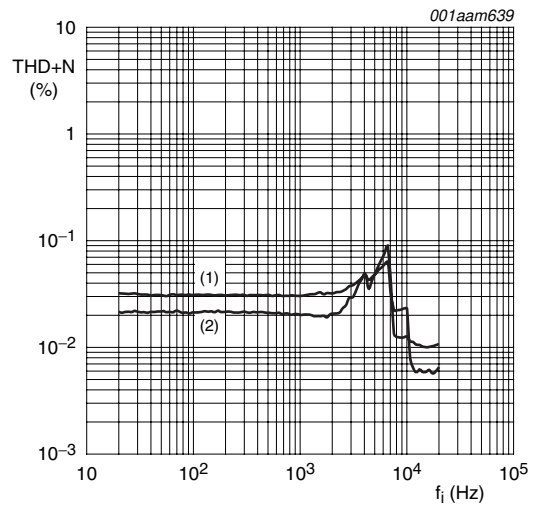

- (1)  $P_o = 1$  W
- (2)  $P_o = 100$  mW
- d.  $V_{DDP} = 5$  V,  $R_L = 4$   $\Omega$ ,  $L_L = 20$   $\mu$ H

Fig 13. THD+N as a function of frequency

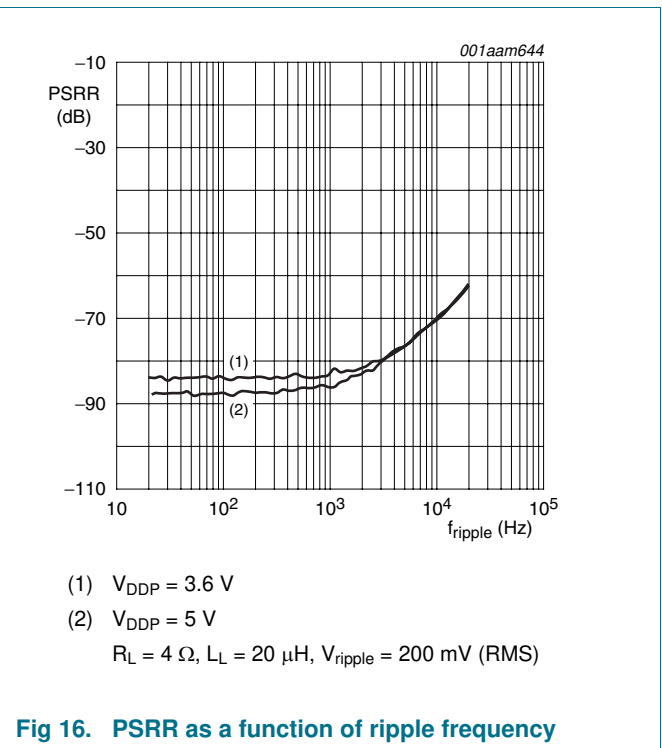
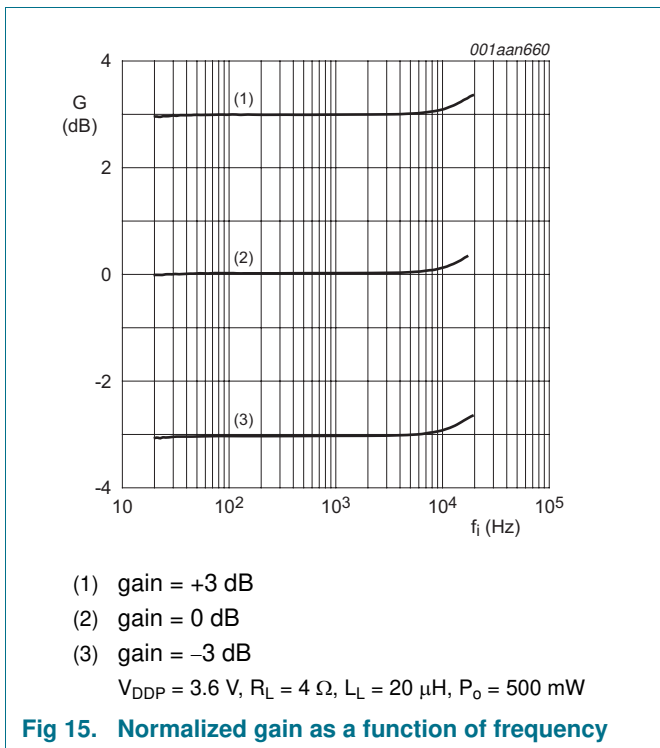
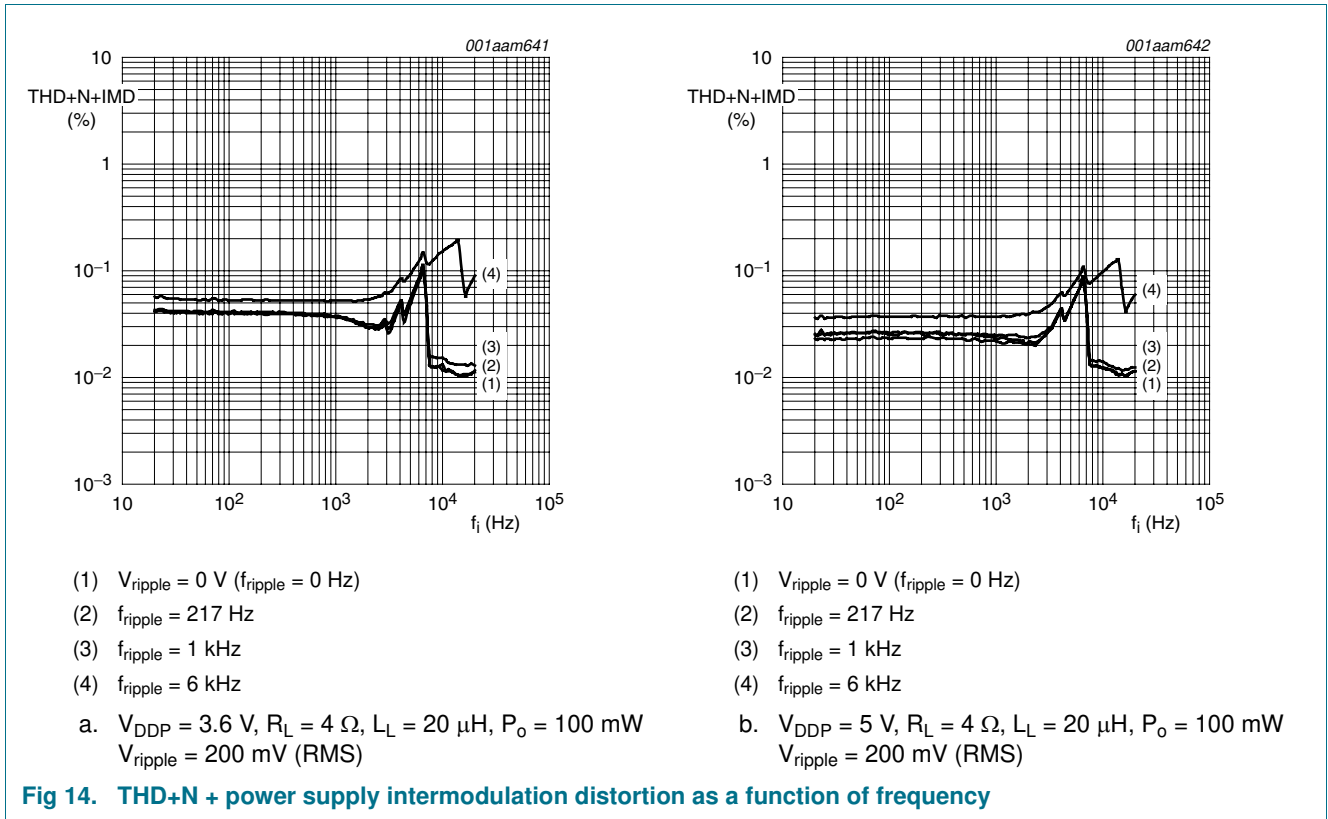

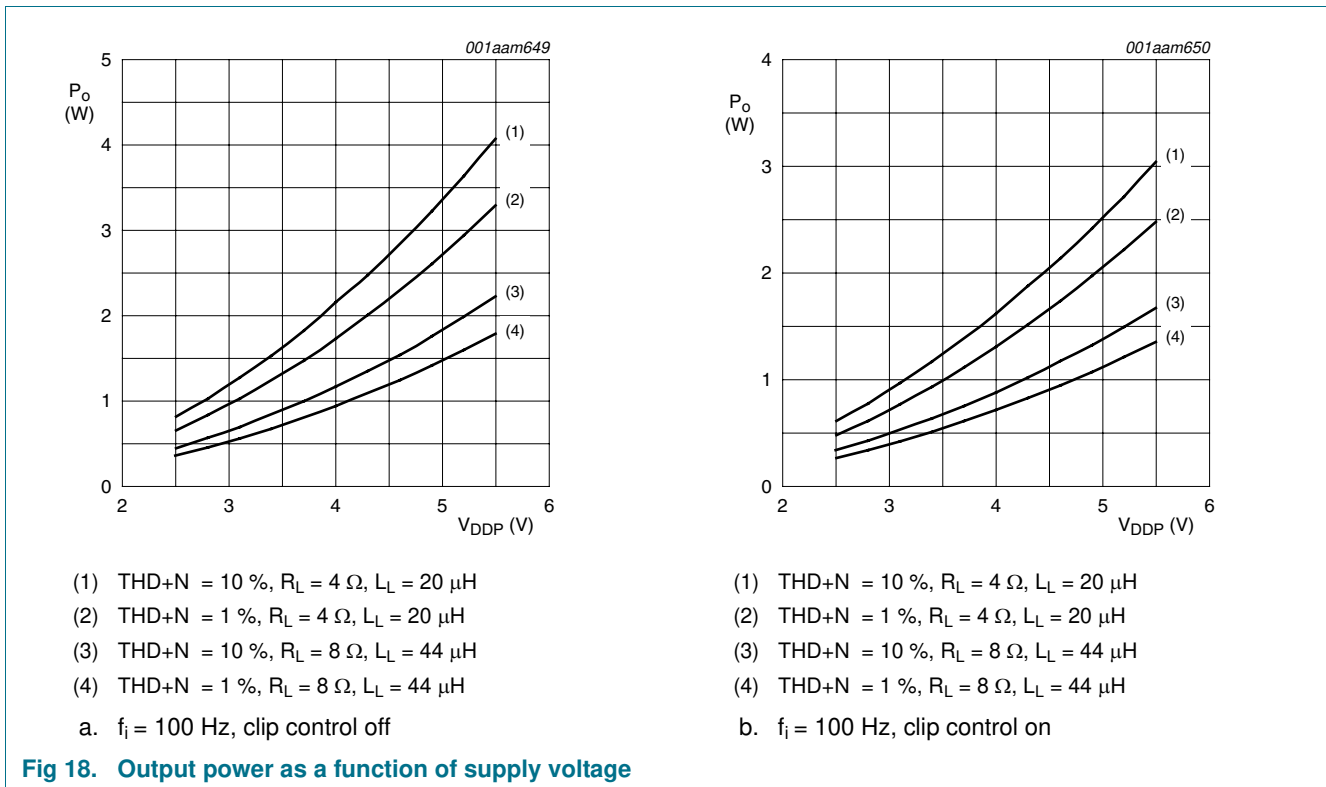
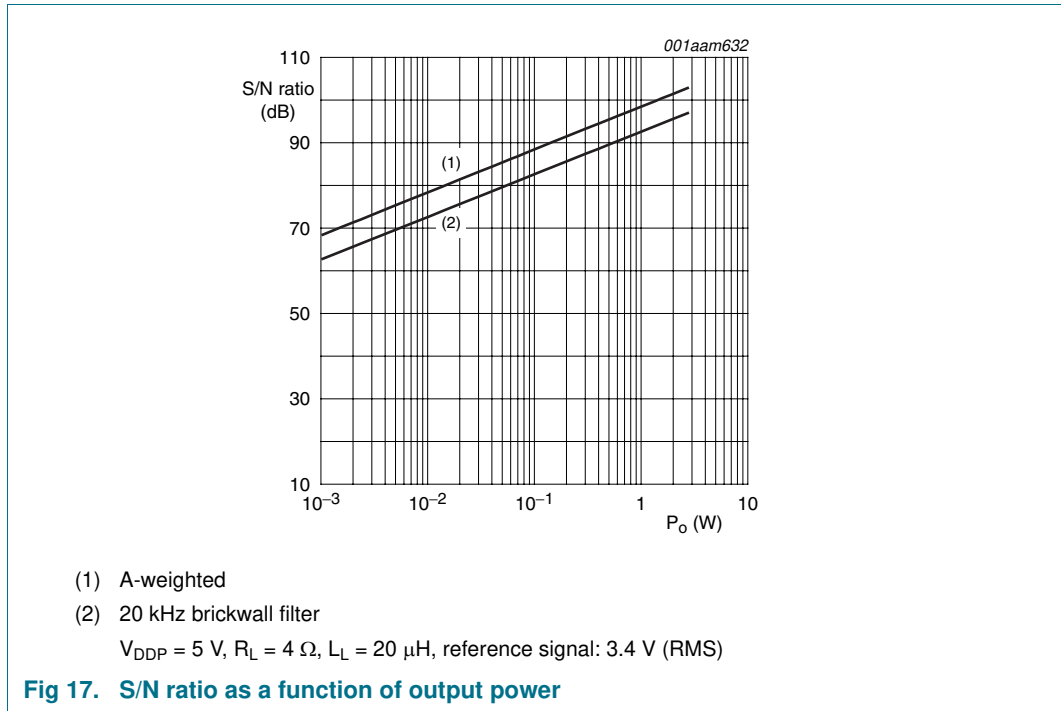

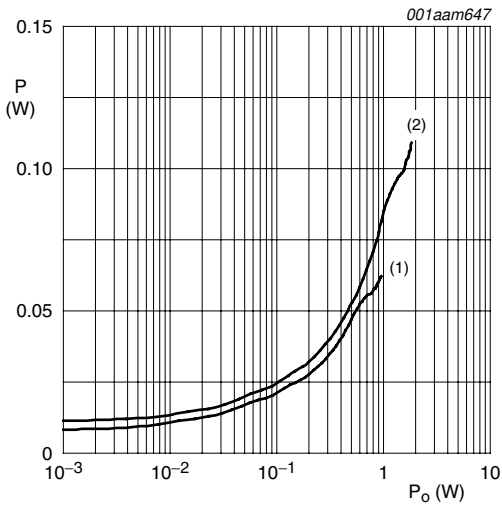

- (1)  $V_{DDP} = 3.6\text{ V}$
- (2)  $V_{DDP} = 5\text{ V}$
- a.  $R_L = 8\ \Omega$ ,  $L_L = 44\ \mu\text{H}$ ,  $f_i = 1\text{ kHz}$ , DPSA on

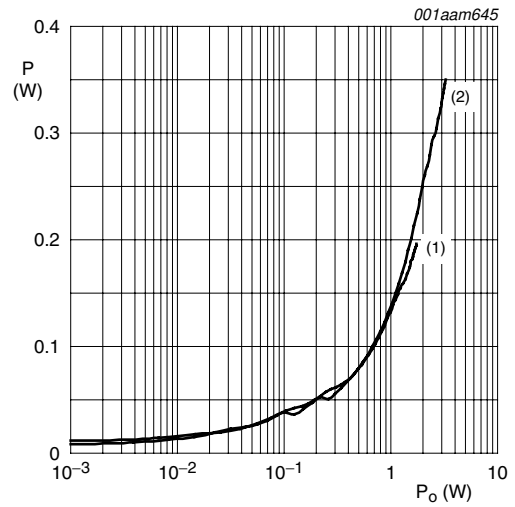

- (1)  $V_{DDP} = 3.6\text{ V}$
- (2)  $V_{DDP} = 5\text{ V}$
- b.  $R_L = 4\ \Omega$ ,  $L_L = 20\ \mu\text{H}$ ,  $f_i = 1\text{ kHz}$ , DPSA on

Fig 19. Power dissipation as a function of output power

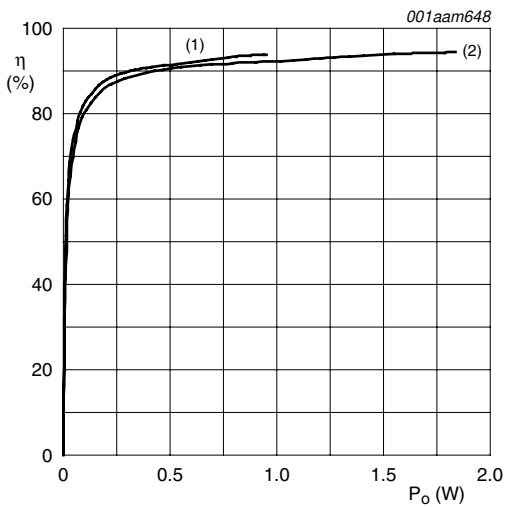

- (1)  $V_{DDP} = 3.6\text{ V}$
- (2)  $V_{DDP} = 5\text{ V}$
- a.  $R_L = 8\ \Omega$ ,  $L_L = 44\ \mu\text{H}$ ,  $f_i = 1\text{ kHz}$ , DPSA on

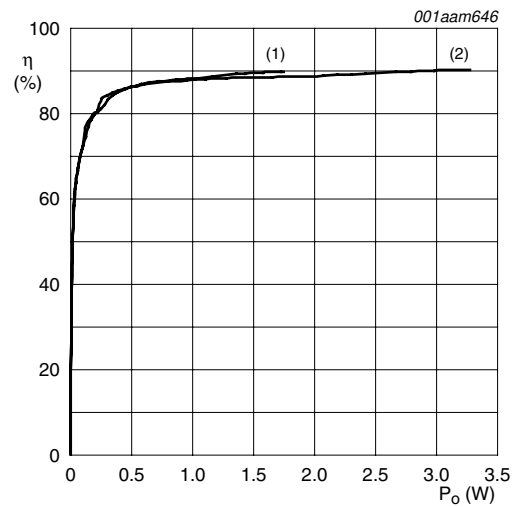

- (1)  $V_{DDP} = 3.6\text{ V}$
- (2)  $V_{DDP} = 5\text{ V}$
- b.  $R_L = 4\ \Omega$ ,  $L_L = 20\ \mu\text{H}$ ,  $f_i = 1\text{ kHz}$ , DPSA on

Fig 20. Efficiency as a function of output power



14. Package outline

WLCSP9: wafer level chip-size package; 9 bumps; body 1.49 x 1.27 mm

TFA9882UK

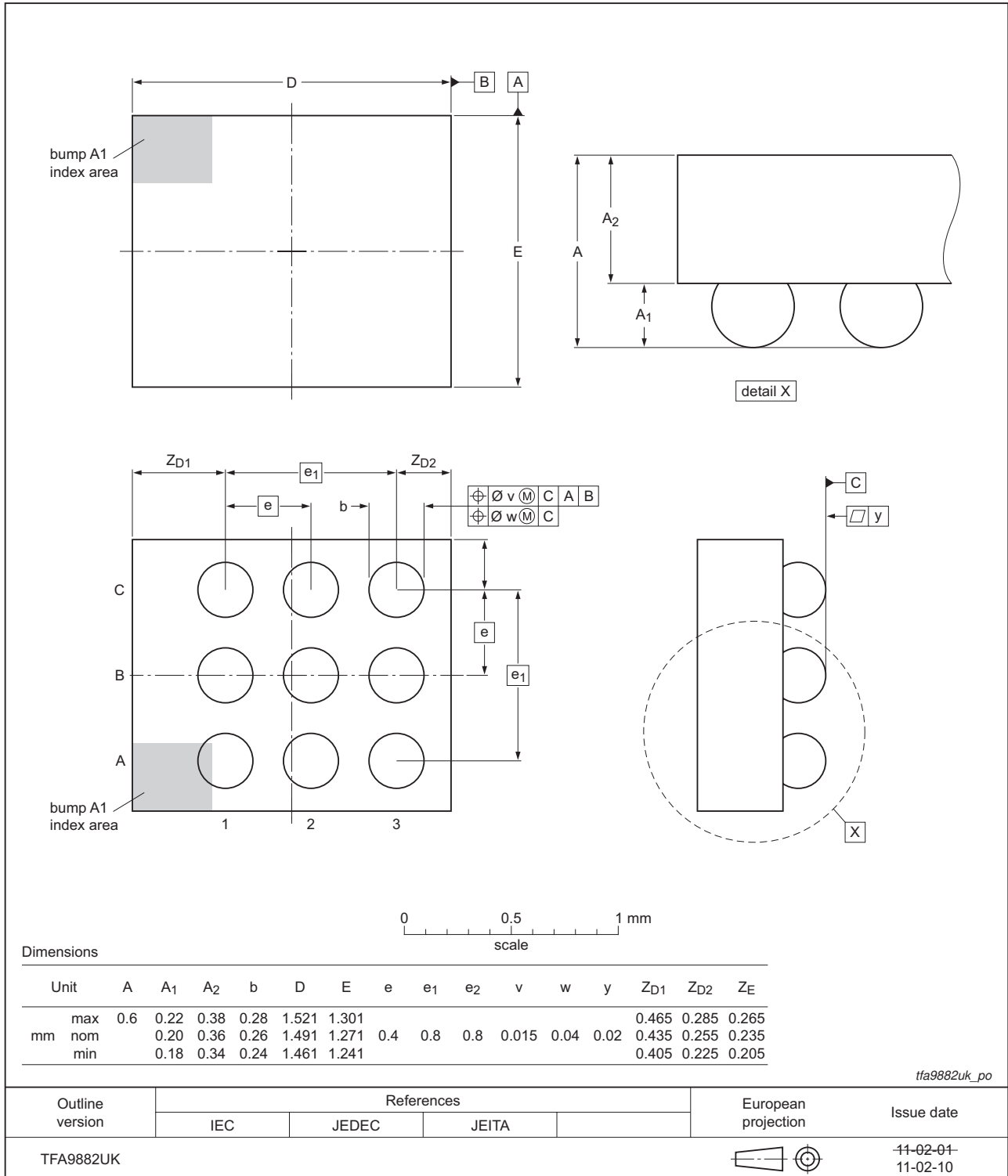

Fig 21. Package outline TFA9882UK (WLCSP9)

## 15. Soldering of WLCSP packages

### 15.1 Introduction to soldering WLCSP packages

This text provides a very brief insight into a complex technology. A more in-depth account of soldering WLCSP (Wafer Level Chip-Size Packages) can be found in application note AN10439 "Wafer Level Chip Scale Package" and in application note AN10365 "Surface mount reflow soldering description".

Wave soldering is not suitable for this package.

All NXP WLCSP packages are lead-free.

### 15.2 Board mounting

Board mounting of a WLCSP requires several steps:

1. Solder paste printing on the PCB
2. Component placement with a pick and place machine
3. The reflow soldering itself

### 15.3 Reflow soldering

Key characteristics in reflow soldering are:

- Lead-free versus SnPb soldering; note that a lead-free reflow process usually leads to higher minimum peak temperatures (see [Figure 22](#)) than a PbSn process, thus reducing the process window
- Solder paste printing issues, such as smearing, release, and adjusting the process window for a mix of large and small components on one board
- Reflow temperature profile; this profile includes preheat, reflow (in which the board is heated to the peak temperature), and cooling down. It is imperative that the peak temperature is high enough for the solder to make reliable solder joints (a solder paste characteristic) while being low enough that the packages and/or boards are not damaged. The peak temperature of the package depends on package thickness and volume and is classified in accordance with [Table 17](#).

**Table 17. Lead-free process (from J-STD-020C)**

Package thickness (mm)	Package reflow temperature (°C)		
	Volume (mm <sup>3</sup> )		
	< 350	350 to 2000	> 2000
< 1.6	260	260	260
1.6 to 2.5	260	250	245
> 2.5	250	245	245

Moisture sensitivity precautions, as indicated on the packing, must be respected at all times.

Studies have shown that small packages reach higher temperatures during reflow soldering, see [Figure 22](#).