



Chipsmall Limited consists of a professional team with an average of over 10 year of expertise in the distribution of electronic components. Based in Hongkong, we have already established firm and mutual-benefit business relationships with customers from,Europe,America and south Asia,supplying obsolete and hard-to-find components to meet their specific needs.

With the principle of “Quality Parts,Customers Priority,Honest Operation,and Considerate Service”,our business mainly focus on the distribution of electronic components. Line cards we deal with include Microchip,ALPS,ROHM,Xilinx,Pulse,ON,Everlight and Freescale. Main products comprise IC,Modules,Potentiometer,IC Socket,Relay,Connector.Our parts cover such applications as commercial,industrial, and automotives areas.

We are looking forward to setting up business relationship with you and hope to provide you with the best service and solution. Let us make a better world for our industry!



## Contact us

Tel: +86-755-8981 8866 Fax: +86-755-8427 6832

Email & Skype: info@chipsmall.com Web: www.chipsmall.com

Address: A1208, Overseas Decoration Building, #122 Zhenhua RD., Futian, Shenzhen, China





# TFF1024HN

## Integrated mixer oscillator PLL for satellite LNB

Rev. 1 — 13 January 2015

Product data sheet

## 1. General description

The TFF1024HN is an integrated downconverter for use in Low Noise Block (LNB) converters in a 10.70 GHz to 12.85 GHz  $K_u$  band satellite receiver system.

## 2. Features and benefits

- Low current consumption integrated pre-amplifier, mixer, buffer amplifier and PLL synthesizer
- Flat gain over frequency
- Single 5 V supply pin
- Low cost 25 MHz crystal
- Crystal controlled LO frequency generation
- Switched LO frequency (selectable to 9.75 GHz, 10.00 GHz, 10.25 GHz, 10.55 GHz, 10.60 GHz, 10.75 GHz, 11.25 GHz or 11.30 GHz) with a 25 MHz crystal as reference
- Other LO frequencies within the 9.75 GHz to 11.30 GHz range can be realized by using an alternative reference frequency
- Low phase noise
- Low spurious
- Low external component count
- Alignment-free concept
- ESD protection on all pins

## 3. Applications

- $K_u$  band LNB converters for VSAT and digital satellite reception (DVB-S / DVB-S2)

## 4. Quick reference data

**Table 1. Quick reference data**

$9.75 \text{ GHz} \leq f_{LO} \leq 11.30 \text{ GHz}$ ; operating conditions of [Table 6](#) apply.

Symbol	Parameter	Conditions	Min	Typ	Max	Unit
$V_{CC}$	supply voltage	RF input and IF output AC coupled	[1] 4.5	5	5.5	V
$I_{CC}$	supply current	RF input and IF output AC coupled	[1] -	56	70	mA
$NF_{SSB}$	single sideband noise figure	$f_{IF} = 1450 \text{ MHz}$ ; $T_{amb} = 25 \text{ °C}$ ; $10.55 \text{ GHz} \leq f_{LO} \leq 10.60 \text{ GHz}$	-	9.0	11.0	dB
$f_{RF}$	RF frequency		[2] 10.70	-	12.85	GHz



**Table 1. Quick reference data ...continued**  
 $9.75 \text{ GHz} \leq f_{LO} \leq 11.30 \text{ GHz}$ ; operating conditions of [Table 6](#) apply.

Symbol	Parameter	Conditions	Min	Typ	Max	Unit
$G_{conv}$	conversion gain	$f_{IF} = 1450 \text{ MHz}$				
		$f_{LO} = 10.55 \text{ GHz}$	29.8	34.3	38.8	dB
		$f_{LO} = 10.60 \text{ GHz}$	29.8	34.3	38.8	dB
$S_{11}$	input reflection coefficient	$10.70 \text{ GHz} \leq f_{RF} \leq 12.85 \text{ GHz}$	-	-10	-	dB
$S_{22}$	output reflection coefficient	$950 \text{ MHz} \leq f_{IF} \leq 2150 \text{ MHz}; Z_0 = 75 \Omega$	-	-10	-	dB
$IP_{3o}$	output third-order intercept point	carrier power = -10 dBm (measured at output)				
		$f_{IF} = 1450 \text{ MHz}; 9.75 \text{ GHz} \leq f_{LO} \leq 10.75 \text{ GHz}$	14	18	-	dBm
		$f_{IF} = 1250 \text{ MHz}; 11.25 \text{ GHz} \leq f_{LO} \leq 11.30 \text{ GHz}$	14	18	-	dBm

- [1] DC values.
- [2] See [Table 4](#) for specific values at certain settings of pins HB0, HB1 and HB2.

## 5. Ordering information

**Table 2. Ordering information**

Type number	Package		Version
	Name	Description	
TFF1024HN	DHVQFN16	plastic dual in-line compatible thermal enhanced very thin quad flat package; no leads; 16 terminals; body $2.5 \times 3.5 \times 0.85 \text{ mm}$	SOT763-1

## 6. Functional diagram

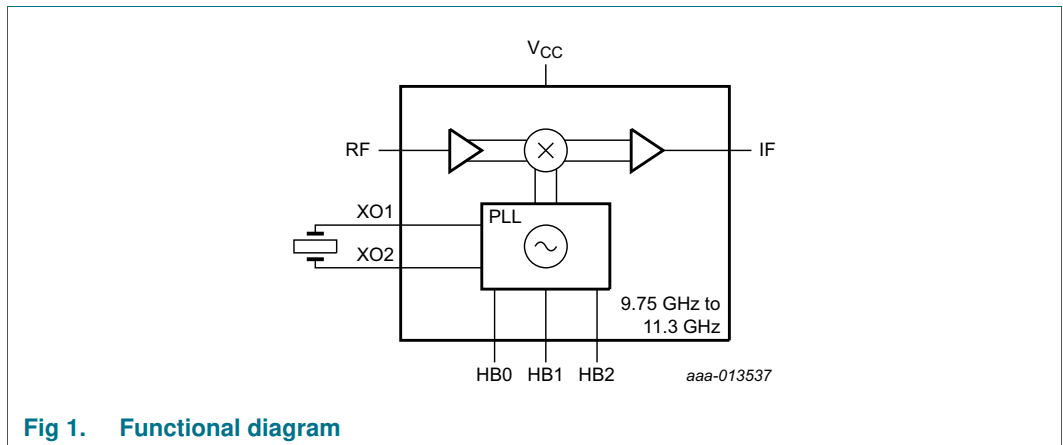

## 7. Pinning information

### 7.1 Pinning

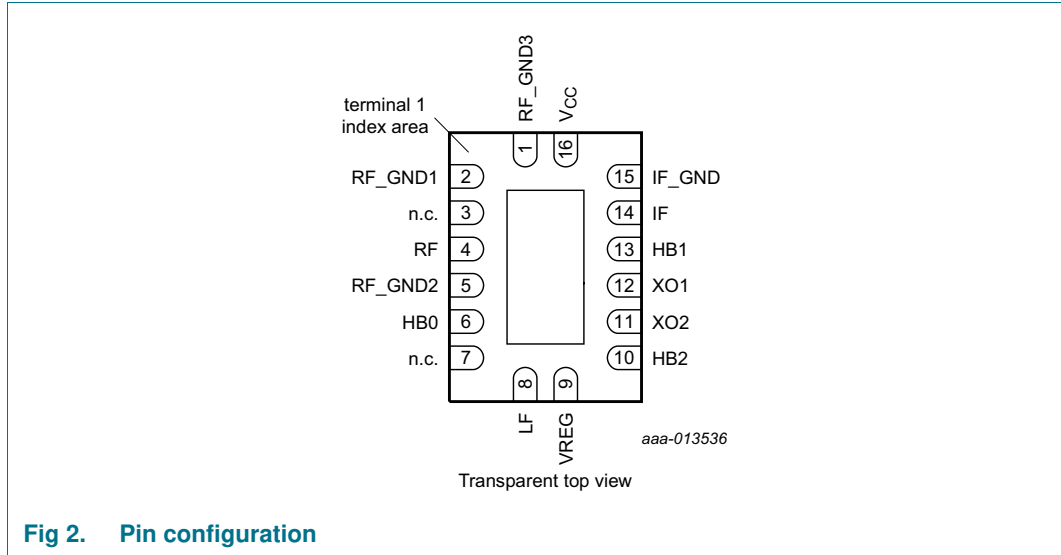

Fig 2. Pin configuration

### 7.2 Pin description

Table 3. Pin description

Symbol	Pin	Description
GND	0	ground (exposed die pad)
RF_GND3	1	RF ground. Connect this pin to the exposed die pad landing.
RF_GND1	2	RF ground. Connect this pin to the exposed die pad landing and the RF input CPW line.
n.c.	3	not connected. Connect to RF on PCB. [1]
RF	4	RF input.
RF_GND2	5	RF ground. Connect this pin to the exposed die pad landing and the RF input CPW line.
HB0	6	LO frequency selection, LSB. Connect this pin to GND for "0", leave open for "1". Also see Table 4.
n.c.	7	not connected. Use this pin to route the ground layer on top of the PCB to the exposed die pad.
LF	8	Loop filter PLL. Connect loop filter between this pin and VREG (pin 9).
VREG	9	Regulated output voltage for PLL loop filter. Connect loop filter to this pin. Decouple against die pad via pin 7.
HB2	10	LO frequency selection, MSB. Connect this pin to GND for "0", leave open for "1". Also see Table 4.
XO2	11	Crystal connection 2. Connect crystal between this pin and XO1 (pin 12).
XO1	12	Crystal connection 1. Connect crystal between this pin and XO2 (pin 11).
HB1	13	LO frequency selection. Connect this pin to GND for "0", leave open for "1". Also see Table 4.
IF	14	IF output
IF_GND	15	IF output ground. Connect this pin to the exposed die pad landing and the output transmission line ground.
VCC	16	Supply voltage

[1] The distance between the outer edges of pin 2 and pin 3 is 740 μm. This gives an optimum transition from a 1.1 mm wide, Z<sub>0</sub> = 50 Ω line to the TFF1024HN on a Rogers RO4223 Printed-Circuit Board (PCB) material of 0.5 mm height.

## 8. Functional description

### 8.1 LO frequency selection

**Table 4. LO frequency selection table**

See [Figure 1](#) for the functional diagram.

f <sub>LO</sub> (GHz)	f <sub>xtal</sub> (MHz)	HB2 (pin 10)	HB1 (pin 13)	HB0 (pin 6)	f <sub>RF</sub> (GHz)		f <sub>IF</sub> (MHz)	
					Min	Max	Min	Max
9.75	25	0	0	0	10.70	11.90	950	2150
10.00	25	0	0	1	10.95	12.15	950	2150
10.25	25	0	1	0	11.20	12.40	950	2150
10.45 <a href="#">[1]</a>	24.76	0	1	1	11.40	12.60	950	2150
10.55	25	0	1	1	11.50	12.70	950	2150
10.60	25	1	0	0	11.55	12.75	950	2150
10.75	25	1	0	1	11.70	12.85	950	2100
11.25	25	1	1	0	12.20	12.85	950	1600
11.30	25	1	1	1	12.25	12.85	950	1550

[1] For frequencies that cannot be achieved using the 25 MHz crystal choose the closest frequency and adapt the crystal frequency.

Example: 10.45 GHz. This can be achieved by choosing 10.55 GHz. The divider ratio is 422. 10.45 GHz will be achieved with a crystal frequency of 10.45 GHz / 422 = 24.76303 MHz.

## 9. Limiting values

**Table 5. Limiting values**

In accordance with the Absolute Maximum Rating System (IEC 60134).

Symbol	Parameter	Conditions	Min	Max	Unit
V <sub>CC</sub>	supply voltage		-0.5	+6	V
V <sub>i</sub>	input voltage	on pin HB0	-0.5	+6	V
		on pin HB1	-0.5	+6	V
		on pin HB2	-0.5	+6	V
T <sub>stg</sub>	storage temperature		-40	+125	°C

## 10. Recommended operating conditions

**Table 6. Operating conditions**

Symbol	Parameter	Conditions	Min	Typ	Max	Unit
V <sub>CC</sub>	supply voltage	RF input and IF output AC coupled <a href="#">[1]</a>	4.5	5	5.5	V
V <sub>i</sub>	input voltage	on pin HB0	0	-	2.7	V
		on pin HB1	0	-	2.7	V
		on pin HB2	0	-	2.7	V
I <sub>CC(startup)</sub>	start-up supply current	during 30 ms only at supply power-on	300	-	-	mA
T <sub>amb</sub>	ambient temperature		-40	+25	+85	°C
Z <sub>0</sub>	characteristic impedance		-	50	-	Ω
f <sub>RF</sub>	RF frequency	<a href="#">[2]</a>	10.70	-	12.85	GHz

Table 6. Operating conditions ...continued

Symbol	Parameter	Conditions	Min	Typ	Max	Unit
f <sub>LO</sub>	LO frequency	HB2 = 0; HB1 = 0; HB0 = 0 [3]	-	9.75	-	GHz
		HB2 = 1; HB1 = 1; HB0 = 1 [4]	-	11.30	-	GHz
f <sub>IF</sub>	IF frequency	[2]	950	-	2150	MHz
C <sub>L(xtal)</sub>	crystal load capacitance		-	10	-	pF
ESR	equivalent series resistance		-	-	40	Ω
f <sub>xtal</sub>	crystal frequency		-	25	-	MHz

[1] DC values.

[2] See Table 4 for specific values at certain settings of pins HB0, HB1 and HB2.

[3] The minimum LO frequency is specified. See Table 4 for other specific values at certain settings of pins HB0, HB1 and HB2.

[4] The maximum LO frequency is specified. See Table 4 for other specific values at certain settings of pins HB0, HB1 and HB2.

## 11. Thermal characteristics

Table 7. Thermal characteristics

Symbol	Parameter	Conditions	Typ	Unit
R <sub>th(j-c)</sub>	thermal resistance from junction to case		35	K/W

## 12. Characteristics

Table 8. Characteristics

9.75 GHz ≤ f<sub>LO</sub> ≤ 11.30 GHz; operating conditions of Table 6 apply.

Symbol	Parameter	Conditions	Min	Typ	Max	Unit
I <sub>CC</sub>	supply current	RF input and IF output AC coupled [1]	-	56	70	mA
Φ <sub>nλ(itg)</sub> RMS	RMS integrated phase noise density	loop bandwidth = crossover bandwidth; low ESR crystal used (ESR < 20 Ω)				
		integration offset frequency = 1 kHz to 1 MHz	-	1.2	2.2	deg
		integration offset frequency = 10 kHz to 13 MHz	-	1.2	2.2	deg
NF <sub>SSB</sub>	single sideband noise figure	f <sub>IF</sub> = 1450 MHz; T <sub>amb</sub> = 25 °C				
		f <sub>LO</sub> = 9.75 GHz	-	8.8	10.8	dB
		10.55 GHz ≤ f <sub>LO</sub> ≤ 10.60 GHz	-	9.0	11.0	dB
		f <sub>IF</sub> = 1250 MHz; T <sub>amb</sub> = 25 °C				
G <sub>conv</sub>	conversion gain	11.25 GHz ≤ f <sub>LO</sub> ≤ 11.30 GHz	-	9.5	11.5	dB
		f <sub>IF</sub> = 1450 MHz				
		f <sub>LO</sub> = 9.75 GHz	29.6	34.1	38.6	dB
		f <sub>LO</sub> = 10.00 GHz	29.5	34.0	38.5	dB
		f <sub>LO</sub> = 10.25 GHz	29.5	34.0	38.5	dB
		f <sub>LO</sub> = 10.55 GHz	29.8	34.3	38.8	dB
		f <sub>LO</sub> = 10.60 GHz	29.8	34.3	38.8	dB
		f <sub>LO</sub> = 10.75 GHz	30.2	34.7	39.2	dB
		f <sub>IF</sub> = 1250 MHz				
f <sub>LO</sub> = 11.25 GHz	30.2	34.7	39.2	dB		
f <sub>LO</sub> = 11.30 GHz	30.1	34.6	39.1	dB		

**Table 8. Characteristics ...continued**  
 9.75 GHz ≤ f<sub>LO</sub> ≤ 11.30 GHz; operating conditions of [Table 6](#) apply.

Symbol	Parameter	Conditions	Min	Typ	Max	Unit	
ΔG <sub>conv</sub> /Δf	conversion gain variation with frequency	over IF band; -40 °C ≤ T <sub>amb</sub> ≤ +85 °C; V <sub>CC</sub> = 5.0 V					
		f <sub>LO</sub> = 9.75 GHz	[2]	-	-	2.5	dB
		f <sub>LO</sub> = 10.00 GHz	[2]	-	-	3.0	dB
		f <sub>LO</sub> = 10.25 GHz	[2]	-	-	3.6	dB
		f <sub>LO</sub> = 10.55 GHz	[2]	-	-	4.0	dB
		f <sub>LO</sub> = 10.60 GHz	[2]	-	-	4.0	dB
		f <sub>LO</sub> = 10.75 GHz	[2]	-	-	4.0	dB
		f <sub>LO</sub> = 11.25 GHz	[2]	-	-	3.0	dB
		f <sub>LO</sub> = 11.30 GHz	[2]	-	-	3.0	dB
	in every 36 MHz band; -40 °C ≤ T <sub>amb</sub> ≤ +85 °C; V <sub>CC</sub> = 5.0 V		-	-	0.6	dB	
S <sub>11</sub>	input reflection coefficient	10.70 GHz ≤ f <sub>RF</sub> ≤ 12.85 GHz	-	-10	-	dB	
S <sub>22</sub>	output reflection coefficient	950 MHz ≤ f <sub>IF</sub> ≤ 2150 MHz; Z <sub>0</sub> = 75 Ω	-	-10	-	dB	
IP <sub>3o</sub>	output third-order intercept point	carrier power is -10 dBm (measured at the output)					
		f <sub>IF</sub> = 1450 MHz; 9.75 GHz ≤ f <sub>LO</sub> ≤ 10.75 GHz	14	18	-	dBm	
		f <sub>IF</sub> = 1250 MHz; 11.25 GHz ≤ f <sub>LO</sub> ≤ 11.30 GHz	14	18	-	dBm	
P <sub>L(1dB)</sub>	output power at 1 dB gain compression	measured at the output					
		f <sub>IF</sub> = 1450 MHz; 9.75 GHz ≤ f <sub>LO</sub> ≤ 10.75 GHz	2	6	-	dBm	
		f <sub>IF</sub> = 1250 MHz; 11.25 GHz ≤ f <sub>LO</sub> ≤ 11.30 GHz	2	6	-	dBm	
α <sub>L(RF)o</sub>	local oscillator RF leakage	f <sub>c</sub> = f <sub>LO</sub> ; span = 100 MHz; RBW = 50 kHz; VBW = 200 kHz	-	-	-35	dBm	
V <sub>IL</sub>	LOW-level input voltage	on pin HB0	-	-	0.8	V	
		on pin HB1	-	-	0.8	V	
		on pin HB2	-	-	0.8	V	
V <sub>IH</sub>	HIGH-level input voltage	on pin HB0	1.6	-	2.7	V	
		on pin HB1	1.6	-	2.7	V	
		on pin HB2	1.6	-	2.7	V	
R <sub>pu</sub>	pull-up resistance	on pin HB0	80	110	140	kΩ	
		on pin HB1	80	110	140	kΩ	
		on pin HB2	80	110	140	kΩ	

[1] DC values.

[2] See [Table 4](#) for the corresponding f<sub>IF</sub> ranges.

12.1 Graphs

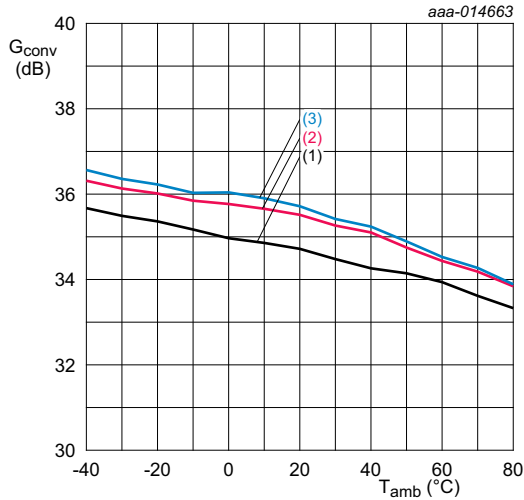

$V_{CC} = 5\text{ V}; f_{IF} = 1550\text{ MHz}.$   
 (1)  $f_{LO} = 9.75\text{ GHz}$   
 (2)  $f_{LO} = 10.60\text{ GHz}$   
 (3)  $f_{LO} = 11.30\text{ GHz}$

**Fig 3. Conversion gain as a function of ambient temperature; typical values**

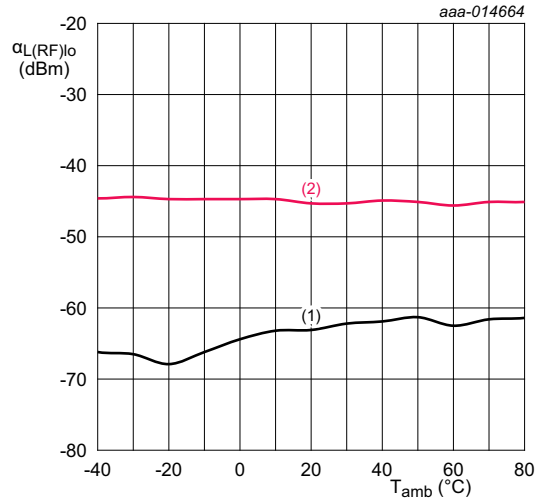

$V_{CC} = 5\text{ V}.$   
 (1)  $f_{LO} = 9.75\text{ GHz}$   
 (2)  $f_{LO} = 11.30\text{ GHz}$

**Fig 4. Local oscillator RF leakage as a function of ambient temperature; typical values**

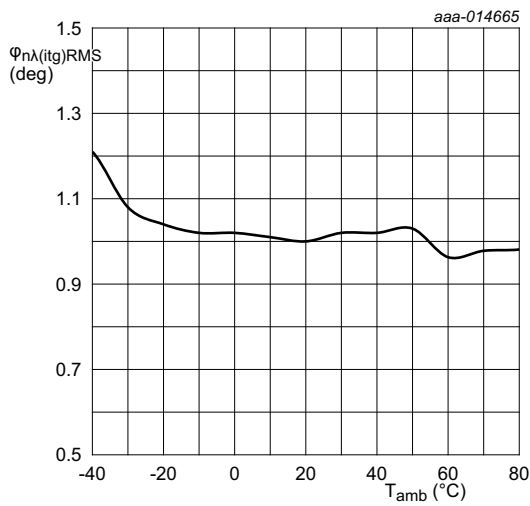

$V_{CC} = 5\text{ V}; f_{LO} = 10.55\text{ GHz}.$

**Fig 5. RMS integrated phase noise density as a function of ambient temperature; typical values**

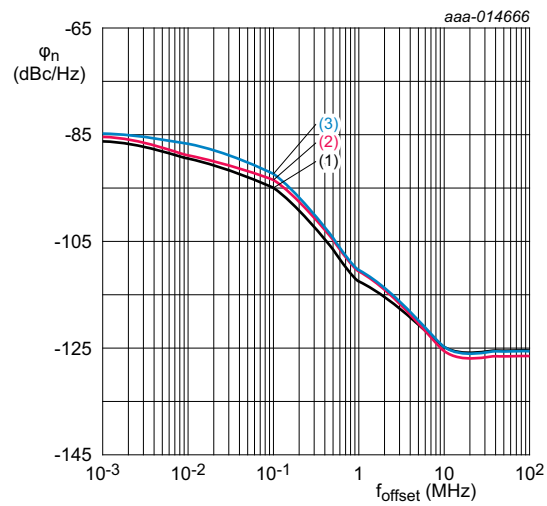

$V_{CC} = 5\text{ V}; T_{amb} = 25\text{ °C}.$   
 (1)  $f_{LO} = 9.75\text{ GHz}$   
 (2)  $f_{LO} = 10.60\text{ GHz}$   
 (3)  $f_{LO} = 11.30\text{ GHz}$

**Fig 6. Phase noise as a function of offset frequency; typical values**



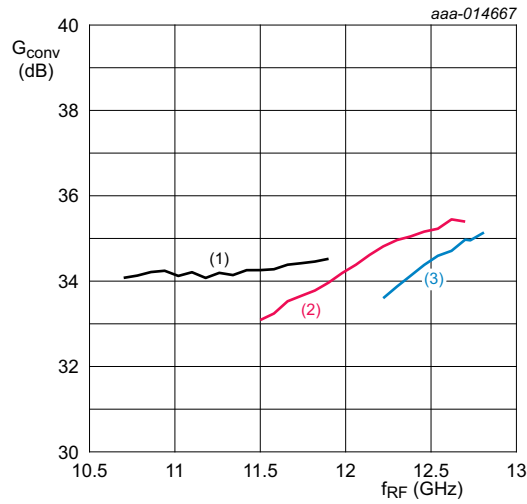

- $V_{CC} = 5\text{ V.}$
- (1)  $f_{LO} = 9.75\text{ GHz}$
  - (2)  $f_{LO} = 10.60\text{ GHz}$
  - (3)  $f_{LO} = 11.30\text{ GHz}$

**Fig 7. Conversion gain as a function of RF frequency; typical values**

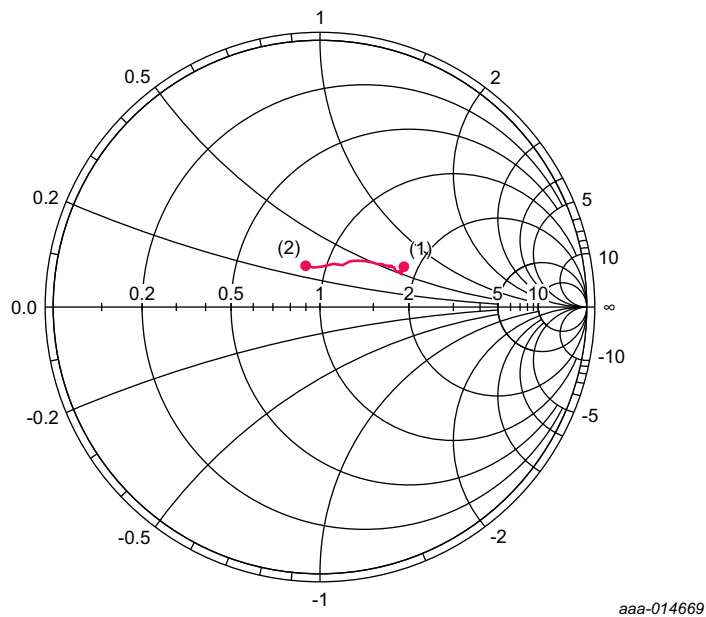

- (1)  $f_{RF} = 10.70\text{ GHz}$
- (2)  $f_{RF} = 12.75\text{ GHz}$

**Fig 8. Input reflection coefficient ( $S_{11}$ ); typical values**

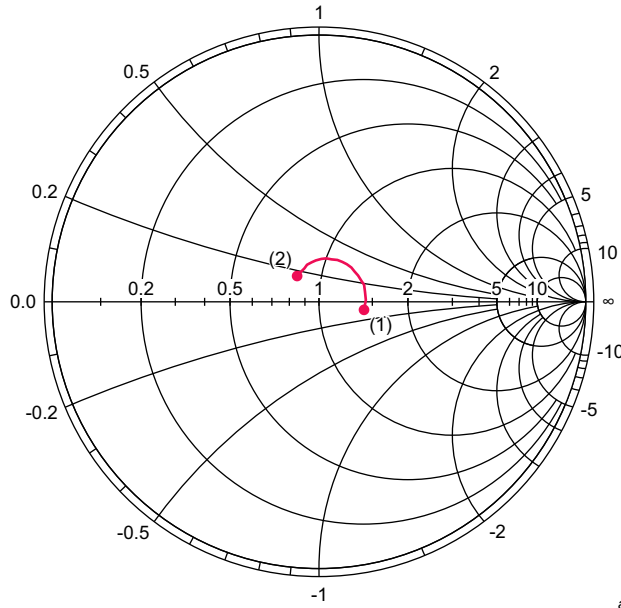

- (1)  $f_{IF} = 250$  MHz
- (2)  $f_{IF} = 2150$  MHz

**Fig 9. Output reflection coefficient ( $S_{22}$ ); typical values**

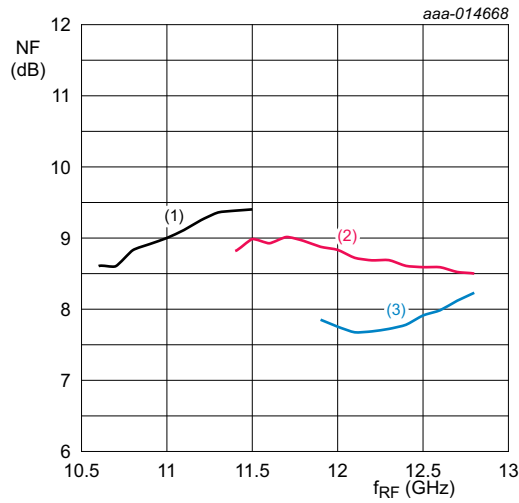

- $V_{CC} = 5$  V.
- (1)  $f_{LO} = 9.75$  GHz
  - (2)  $f_{LO} = 10.60$  GHz
  - (3)  $f_{LO} = 11.30$  GHz

**Fig 10. Noise figure as function of RF frequency; typical values**

13. Application information

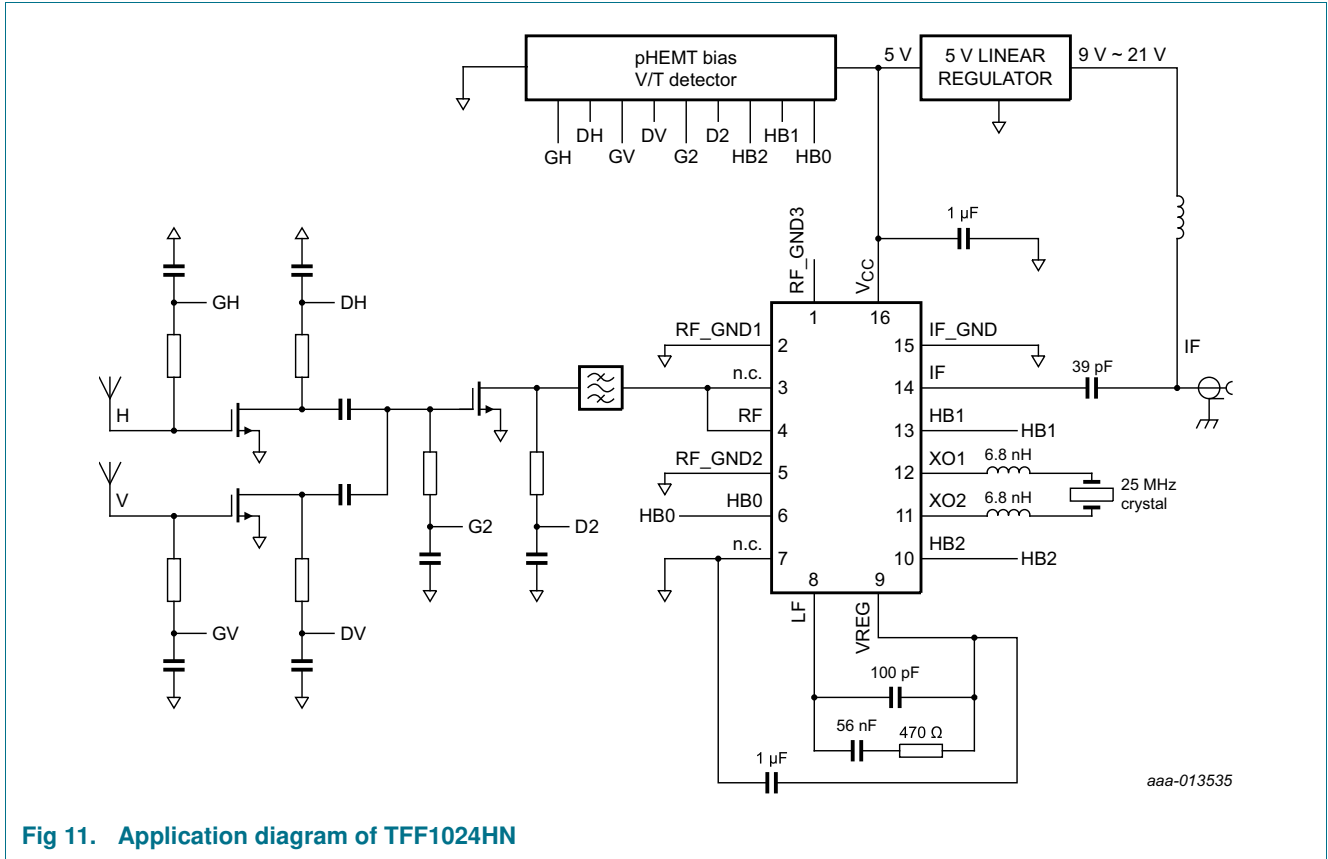
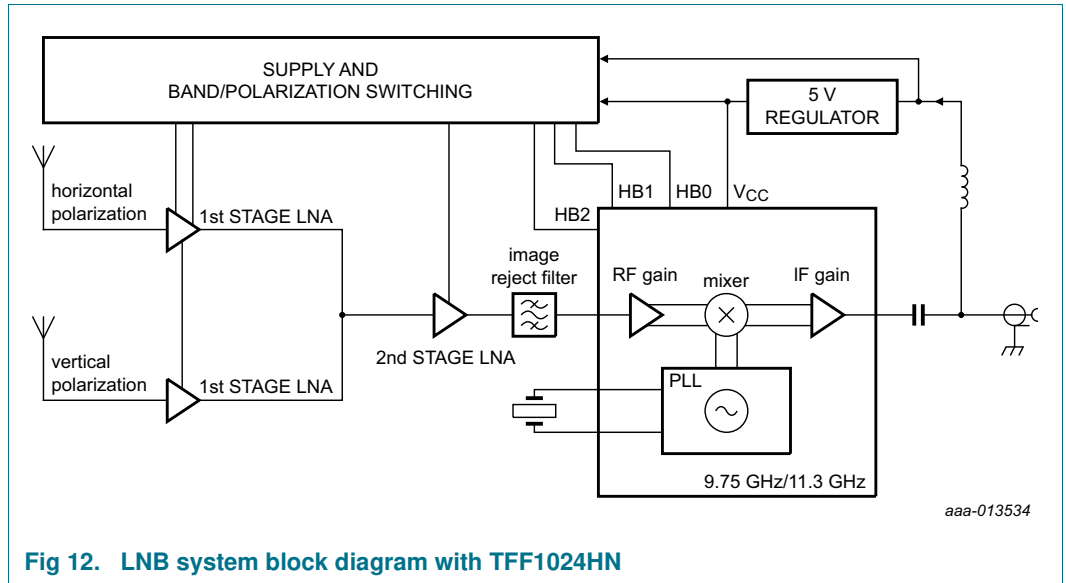

Fig 11. Application diagram of TFF1024HN

Table 9. List of netnames

See [Figure 11](#).

Netname	Description
GH	Gate voltage of 1st stage LNA. Horizontal polarization
DH	Drain voltage of 1st stage LNA. Horizontal polarization
GV	Gate voltage of 1st stage LNA. Vertical polarization
DV	Drain voltage of 1st stage LNA. Vertical polarization
G2	Gate voltage of 2nd stage LNA
D2	Drain voltage of 2nd stage LNA
HB0	LO frequency selection, LSB
HB1	LO frequency selection
HB2	LO frequency selection, MSB



14. Package outline

DHVQFN16: plastic dual in-line compatible thermal enhanced very thin quad flat package; no leads; 16 terminals; body 2.5 x 3.5 x 0.85 mm

SOT763-1

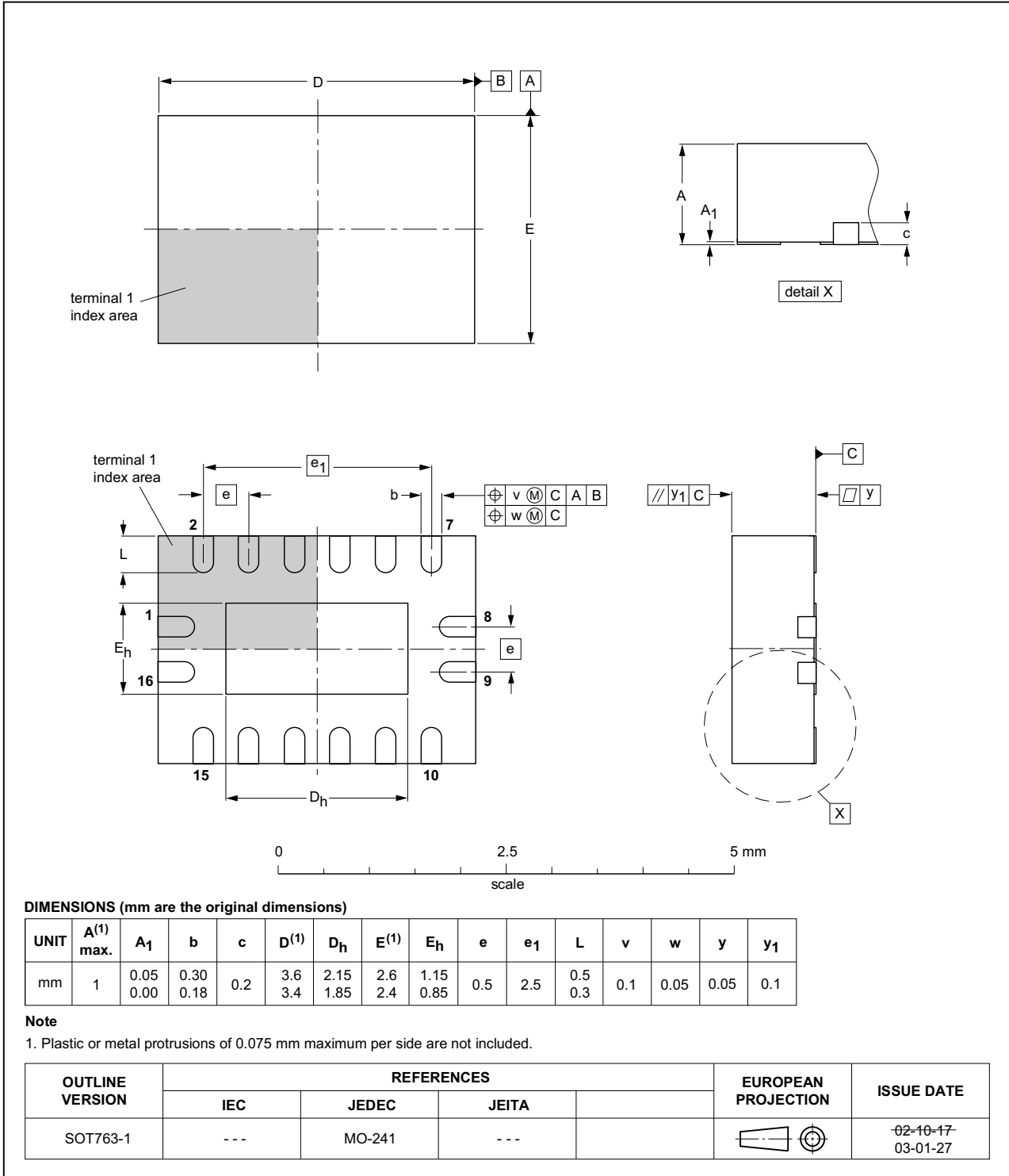

Fig 13. Package outline SOT763-1

## 15. Abbreviations

Table 10. Abbreviations

Acronym	Description
CPW	CoPlanar Waveguide
DVB-S	Digital Video Broadcasting by Satellite
DVB-S2	Digital Video Broadcasting - Satellite - Second generation
ESD	ElectroStatic Discharge
IF	Intermediate Frequency
K <sub>u</sub> band	K-under band
LNA	Low-Noise Amplifier
LNB	Low-Noise Block
LO	Local Oscillator
LSB	Least Significant Bit
MSB	Most Significant Bit
pHEMT	Pseudomorphic High Electron Mobility Transistor
PLL	Phase-Locked Loop
RBW	Resolution BandWidth
VSAT	Very Small Aperture Terminal
V/T	Voltage / Tone
VBW	Video BandWidth

## 16. Revision history

Table 11. Revision history

Document ID	Release date	Data sheet status	Change notice	Supersedes
TFF1024HN v.1	20150113	Product data sheet	-	-

## 17. Legal information

### 17.1 Data sheet status

Document status <sup>[1][2]</sup>	Product status <sup>[3]</sup>	Definition
Objective [short] data sheet	Development	This document contains data from the objective specification for product development.
Preliminary [short] data sheet	Qualification	This document contains data from the preliminary specification.
Product [short] data sheet	Production	This document contains the product specification.

[1] Please consult the most recently issued document before initiating or completing a design.

[2] The term 'short data sheet' is explained in section "Definitions".

[3] The product status of device(s) described in this document may have changed since this document was published and may differ in case of multiple devices. The latest product status information is available on the Internet at URL <http://www.nxp.com>.

### 17.2 Definitions

**Draft** — The document is a draft version only. The content is still under internal review and subject to formal approval, which may result in modifications or additions. NXP Semiconductors does not give any representations or warranties as to the accuracy or completeness of information included herein and shall have no liability for the consequences of use of such information.

**Short data sheet** — A short data sheet is an extract from a full data sheet with the same product type number(s) and title. A short data sheet is intended for quick reference only and should not be relied upon to contain detailed and full information. For detailed and full information see the relevant full data sheet, which is available on request via the local NXP Semiconductors sales office. In case of any inconsistency or conflict with the short data sheet, the full data sheet shall prevail.

**Product specification** — The information and data provided in a Product data sheet shall define the specification of the product as agreed between NXP Semiconductors and its customer, unless NXP Semiconductors and customer have explicitly agreed otherwise in writing. In no event however, shall an agreement be valid in which the NXP Semiconductors product is deemed to offer functions and qualities beyond those described in the Product data sheet.

### 17.3 Disclaimers

**Limited warranty and liability** — Information in this document is believed to be accurate and reliable. However, NXP Semiconductors does not give any representations or warranties, expressed or implied, as to the accuracy or completeness of such information and shall have no liability for the consequences of use of such information. NXP Semiconductors takes no responsibility for the content in this document if provided by an information source outside of NXP Semiconductors.

In no event shall NXP Semiconductors be liable for any indirect, incidental, punitive, special or consequential damages (including - without limitation - lost profits, lost savings, business interruption, costs related to the removal or replacement of any products or rework charges) whether or not such damages are based on tort (including negligence), warranty, breach of contract or any other legal theory.

Notwithstanding any damages that customer might incur for any reason whatsoever, NXP Semiconductors' aggregate and cumulative liability towards customer for the products described herein shall be limited in accordance with the *Terms and conditions of commercial sale* of NXP Semiconductors.

**Right to make changes** — NXP Semiconductors reserves the right to make changes to information published in this document, including without limitation specifications and product descriptions, at any time and without notice. This document supersedes and replaces all information supplied prior to the publication hereof.

**Suitability for use** — NXP Semiconductors products are not designed, authorized or warranted to be suitable for use in life support, life-critical or safety-critical systems or equipment, nor in applications where failure or malfunction of an NXP Semiconductors product can reasonably be expected to result in personal injury, death or severe property or environmental damage. NXP Semiconductors and its suppliers accept no liability for inclusion and/or use of NXP Semiconductors products in such equipment or applications and therefore such inclusion and/or use is at the customer's own risk.

**Applications** — Applications that are described herein for any of these products are for illustrative purposes only. NXP Semiconductors makes no representation or warranty that such applications will be suitable for the specified use without further testing or modification.

Customers are responsible for the design and operation of their applications and products using NXP Semiconductors products, and NXP Semiconductors accepts no liability for any assistance with applications or customer product design. It is customer's sole responsibility to determine whether the NXP Semiconductors product is suitable and fit for the customer's applications and products planned, as well as for the planned application and use of customer's third party customer(s). Customers should provide appropriate design and operating safeguards to minimize the risks associated with their applications and products.

NXP Semiconductors does not accept any liability related to any default, damage, costs or problem which is based on any weakness or default in the customer's applications or products, or the application or use by customer's third party customer(s). Customer is responsible for doing all necessary testing for the customer's applications and products using NXP Semiconductors products in order to avoid a default of the applications and the products or of the application or use by customer's third party customer(s). NXP does not accept any liability in this respect.

**Limiting values** — Stress above one or more limiting values (as defined in the Absolute Maximum Ratings System of IEC 60134) will cause permanent damage to the device. Limiting values are stress ratings only and (proper) operation of the device at these or any other conditions above those given in the Recommended operating conditions section (if present) or the Characteristics sections of this document is not warranted. Constant or repeated exposure to limiting values will permanently and irreversibly affect the quality and reliability of the device.

**Terms and conditions of commercial sale** — NXP Semiconductors products are sold subject to the general terms and conditions of commercial sale, as published at <http://www.nxp.com/profile/terms>, unless otherwise agreed in a valid written individual agreement. In case an individual agreement is concluded only the terms and conditions of the respective agreement shall apply. NXP Semiconductors hereby expressly objects to applying the customer's general terms and conditions with regard to the purchase of NXP Semiconductors products by customer.

**No offer to sell or license** — Nothing in this document may be interpreted or construed as an offer to sell products that is open for acceptance or the grant, conveyance or implication of any license under any copyrights, patents or other industrial or intellectual property rights.

**Export control** — This document as well as the item(s) described herein may be subject to export control regulations. Export might require a prior authorization from competent authorities.

**Non-automotive qualified products** — Unless this data sheet expressly states that this specific NXP Semiconductors product is automotive qualified, the product is not suitable for automotive use. It is neither qualified nor tested in accordance with automotive testing or application requirements. NXP Semiconductors accepts no liability for inclusion and/or use of non-automotive qualified products in automotive equipment or applications.

In the event that customer uses the product for design-in and use in automotive applications to automotive specifications and standards, customer (a) shall use the product without NXP Semiconductors' warranty of the product for such automotive applications, use and specifications, and (b) whenever customer uses the product for automotive applications beyond NXP Semiconductors' specifications such use shall be solely at customer's own risk, and (c) customer fully indemnifies NXP Semiconductors for any

liability, damages or failed product claims resulting from customer design and use of the product for automotive applications beyond NXP Semiconductors' standard warranty and NXP Semiconductors' product specifications.

**Quick reference data** — The Quick reference data is an extract of the product data given in the Limiting values and Characteristics sections of this document, and as such is not complete, exhaustive or legally binding.

**Translations** — A non-English (translated) version of a document is for reference only. The English version shall prevail in case of any discrepancy between the translated and English versions.

## 17.4 Trademarks

Notice: All referenced brands, product names, service names and trademarks are the property of their respective owners.

## 18. Contact information

---

For more information, please visit: <http://www.nxp.com>

For sales office addresses, please send an email to: [salesaddresses@nxp.com](mailto:salesaddresses@nxp.com)



## 19. Contents

<b>1</b>	<b>General description</b> .....	<b>1</b>
<b>2</b>	<b>Features and benefits</b> .....	<b>1</b>
<b>3</b>	<b>Applications</b> .....	<b>1</b>
<b>4</b>	<b>Quick reference data</b> .....	<b>1</b>
<b>5</b>	<b>Ordering information</b> .....	<b>2</b>
<b>6</b>	<b>Functional diagram</b> .....	<b>2</b>
<b>7</b>	<b>Pinning information</b> .....	<b>3</b>
7.1	Pinning .....	3
7.2	Pin description .....	3
<b>8</b>	<b>Functional description</b> .....	<b>4</b>
8.1	LO frequency selection .....	4
<b>9</b>	<b>Limiting values</b> .....	<b>4</b>
<b>10</b>	<b>Recommended operating conditions</b> .....	<b>4</b>
<b>11</b>	<b>Thermal characteristics</b> .....	<b>5</b>
<b>12</b>	<b>Characteristics</b> .....	<b>5</b>
12.1	Graphs .....	7
<b>13</b>	<b>Application information</b> .....	<b>10</b>
<b>14</b>	<b>Package outline</b> .....	<b>12</b>
<b>15</b>	<b>Abbreviations</b> .....	<b>13</b>
<b>16</b>	<b>Revision history</b> .....	<b>13</b>
<b>17</b>	<b>Legal information</b> .....	<b>14</b>
17.1	Data sheet status .....	14
17.2	Definitions .....	14
17.3	Disclaimers .....	14
17.4	Trademarks .....	15
<b>18</b>	<b>Contact information</b> .....	<b>15</b>
<b>19</b>	<b>Contents</b> .....	<b>16</b>

Please be aware that important notices concerning this document and the product(s) described herein, have been included in section 'Legal information'.

© NXP Semiconductors N.V. 2015.

All rights reserved.

For more information, please visit: <http://www.nxp.com>

For sales office addresses, please send an email to: [salesaddresses@nxp.com](mailto:salesaddresses@nxp.com)

Date of release: 13 January 2015

Document identifier: TFF1024HN