



Chipsmall Limited consists of a professional team with an average of over 10 year of expertise in the distribution of electronic components. Based in Hongkong, we have already established firm and mutual-benefit business relationships with customers from,Europe,America and south Asia,supplying obsolete and hard-to-find components to meet their specific needs.

With the principle of “Quality Parts,Customers Priority,Honest Operation,and Considerate Service”,our business mainly focus on the distribution of electronic components. Line cards we deal with include Microchip,ALPS,ROHM,Xilinx,Pulse,ON,Everlight and Freescale. Main products comprise IC,Modules,Potentiometer,IC Socket,Relay,Connector.Our parts cover such applications as commercial,industrial, and automotives areas.

We are looking forward to setting up business relationship with you and hope to provide you with the best service and solution. Let us make a better world for our industry!



Contact us

Tel: +86-755-8981 8866 Fax: +86-755-8427 6832

Email & Skype: info@chipsmall.com Web: www.chipsmall.com

Address: A1208, Overseas Decoration Building, #122 Zhenhua RD., Futian, Shenzhen, China



Features

- Single chip solution with only a few external components
- Stand-alone fixed-frequency user mode
- Programmable multi-channel user mode
- Low current consumption in active mode and very low standby current
- PLL-stabilized RF VCO (LO) with internal varactor diode
- Lock detect output in programmable user mode
- On-chip AFC for extended input frequency acceptance range
- 3wire bus serial control interface
- FSK/ASK mode selection
- FSK for digital data or FM for analog signal reception
- RSSI output for signal strength indication and ASK reception
- Peak detector for ASK detection
- Switchable LNA gain for improved dynamic range
- Automatic PA turn-on after PLL lock
- ASK modulation achieved by PA on/off keying
- 32-pin Low profile Quad Flat Package (LQFP)

Ordering Code

Product Code	Temperature Code	Package Code	Option Code	Packing Form Code
TH7122	E	NE	BAA-000	RE
TH7122	E	NE	BAA-000	TR

Legend:

Temperature Code: E for Temperature Range -40°C to 85°C
 Package Code: NE for LQFP
 Packing Form: RE for Reel, TR for Tray

Ordering example: TH7122ENE-BAA-000-RE

Application Examples

- General bi-directional half duplex digital data RF signaling or analog signal communication
- Remote Keyless Entry (RKE)
- Low-power telemetry systems
- Alarm and security systems
- Wireless access control
- Garage door openers
- Networking solutions
- Active RFID tags
- Remote controls
- Home and building automation

Pin Description

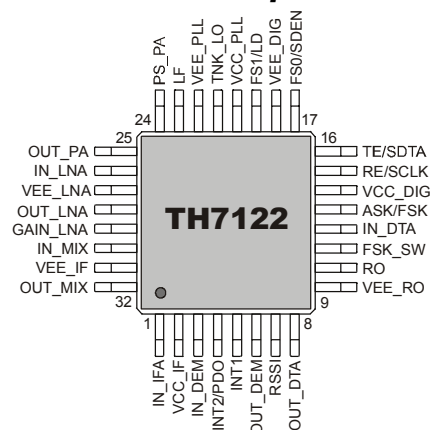

General Description

The TH7122 is a single chip FSK/FM/ASK transceiver IC. It is designed to operate in low-power multi-channel programmable or single-channel stand-alone, half-duplex data transmission systems. It can be used for applications in automotive, industrial-scientific-medical (ISM), short range devices (SRD) or similar applications operating in the frequency range of 300 MHz to 930 MHz. In programmable user mode, the transceiver can operate down to 27 MHz by using an external VCO varactor diode.

Table of Content

1	Theory of Operation	4
1.1	General	4
1.2	Technical Data Overview	4
1.3	Note on ASK Operation	4
1.4	Block Diagram	5
1.5	User Mode Features	5
2	Pin Definitions and Descriptions	6
3	Functional Description	11
3.1	PLL Frequency Synthesizer	11
3.1.1	Reference Oscillator (XOSC)	12
3.1.2	Reference Divider	12
3.1.3	Feedback Divider	12
3.1.4	Frequency Resolution and Operating Frequency	12
3.1.5	Phase-Frequency Detector	13
3.1.6	Lock Detector	13
3.1.7	Voltage Controlled Oscillator with external Loop Filter	14
3.1.8	Loop Filter	14
3.2	Receiver Part	14
3.2.1	LNA	15
3.2.2	Mixer	15
3.2.3	IF Amplifier	15
3.2.4	ASK Demodulator	15
3.2.5	FSK Demodulator	16
3.3	Transmitter Part	16
3.3.1	Power Amplifier	16
3.3.2	Output Power Adjustment	17
3.3.3	Modulation Schemes	17
3.3.4	ASK Modulation	17
3.3.5	FSK Modulation	18
3.3.6	Crystal Tuning	18
4	Description of User Modes	19
4.1	Stand-alone User Mode Operation	19
4.1.1	Frequency Selection	19
4.1.2	Operation Mode	19
4.1.3	Modulation Type	20
4.1.4	LNA Gain Mode	20
4.2	Programmable User Mode Operation	20
4.2.1	Serial Control Interface Description	20
5	Register Description	21
5.1	Register Overview	22
5.1.1	Default Register Settings for FS0, FS1	22

5.1.2	A – word	23
5.1.3	B – word	24
5.1.4	C – word	25
5.1.5	D – word	26
6	Technical Data	27
6.1	Absolute Maximum Ratings	27
6.2	Normal Operating Conditions	27
6.3	DC Characteristics	28
6.4	PLL Synthesizer Timings	30
6.5	AC Characteristics of the Receiver Part	30
6.6	AC Characteristics of the Transmitter Part	31
6.7	Serial Control Interface	31
6.8	Crystal Parameters	31
7	Application Circuit Examples	32
7.1	FSK Application Circuit Programmable User Mode (internal AFC option)	32
7.2	FSK Application Circuit Stand-alone User Mode	33
7.3	FSK Test Circuit Component List (Fig. 14 and Fig. 15)	34
7.4	ASK Application Circuit Programmable User Mode (normal data slicer option)	35
7.5	ASK Test Circuit Component List (Fig. 16)	36
7.6	ASK Application Circuit Programmable User Mode (peak detector option)	37
7.7	ASK Test Circuit Component List (Fig. 17)	38
8	Extended Frequency Range	39
8.1	Board Component List (Fig. 18)	39
9	TX/RX Combining Network	40
9.1	Board Component List (Fig. 19)	40
9.2	Typical LNA S-Parameters in Receive Mode	40
9.3	LNA Input Impedances in Transmit Mode	41
10	Package Description	42
10.1	Soldering Information	42
11	Manufacturability Information	43
12	ESD Precautions	43
13	Disclaimer	45

1 Theory of Operation

1.1 General

The main building block of the transceiver is a programmable PLL frequency synthesizer that is based on an integer-N topology. The PLL is used for generating the carrier frequency during transmission and for generating the LO signal during reception. The carrier frequency can be FSK-modulated either by pulling the crystal or by modulating the VCO directly. ASK modulation is done by on/off keying of the power amplifier. The receiver is based on the principle of a single conversion superhet. Therefore the VCO frequency has to be changed between transmit and receive mode. In receive mode, the default LO injection type is low-side injection.

The TH7122 transceiver IC consists of the following building blocks:

- Low-noise amplifier (LNA) for high-sensitivity RF signal reception with switchable gain
- Mixer (MIX) for RF-to-IF down-conversion
- IF amplifier (IFA) to amplify and limit the IF signal and for RSSI generation
- Phase-coincidence FSK demodulator with external ceramic discriminator or LC tank
- Operational amplifier (OA1), connected to demodulator output
- Operational amplifier (OA2), for general use
- Peak detector (PKDET) for ASK detection
- Control logic with 3wire bus serial control interface (SCI)
- Reference oscillator (RO) with external crystal
- Reference divider (R counter)
- Programmable divider (N/A counter)
- Phase-frequency detector (PFD)
- Charge pump (CP)
- Voltage controlled oscillator (VCO) with internal varactor diode
- Power amplifier (PA) with adjustable output power

1.2 Technical Data Overview

- | | |
|--|--|
| <ul style="list-style-type: none"> ❑ Frequency range: 300 MHz to 930 MHz in programmable user mode ❑ Extended frequency range with external VCO varactor diode: 27 MHz to 930 MHz ❑ 315 MHz, 433 MHz, 868 MHz or 915 MHz fixed-frequency settings in stand-alone mode ❑ Power supply range: 2.2 V to 5.5 V ❑ Temperature range: -40 °C to +85 °C ❑ Standby current: 0.05 µA ❑ Operating current in receive: 6.5 mA (low gain) ❑ Operating current in transmit: 12 mA (at -2 dBm) ❑ Adjustable RF power range: -20 dBm to +10dBm ❑ Sensitivity: -105 dBm at FSK with 180 kHz IF filter BW | <ul style="list-style-type: none"> ❑ Sensitivity: -107 dBm at ASK with 180 kHz IF filter BW ❑ Max. data rate with crystal pulling: 20 kbps NRZ ❑ Max. data rate with direct VCO modulation: 115 kbps NRZ ❑ Max. input level: -10 dBm at FSK and -20 dBm at ASK ❑ Input frequency acceptance: ± 10 to ± 150 kHz (depending on FSK deviation) ❑ FM/FSK deviation range: ±2.5 to ±80 kHz ❑ Analog modulation frequency: max. 10 kHz ❑ Crystal reference frequency: 3 MHz to 12 MHz ❑ External reference frequency: 1 MHz to 16 MHz |
|--|--|

1.3 Note on ASK Operation

Optimum ASK performance can be achieved by using an 8-MHz crystal for operation at 315 MHz, 434 MHz and 915 MHz. For details please refer to the software settings shown in sections 7.4 and 7.6. FSK operation is the preferred choice for applications in the European 868MHz band.

1.4 Block Diagram

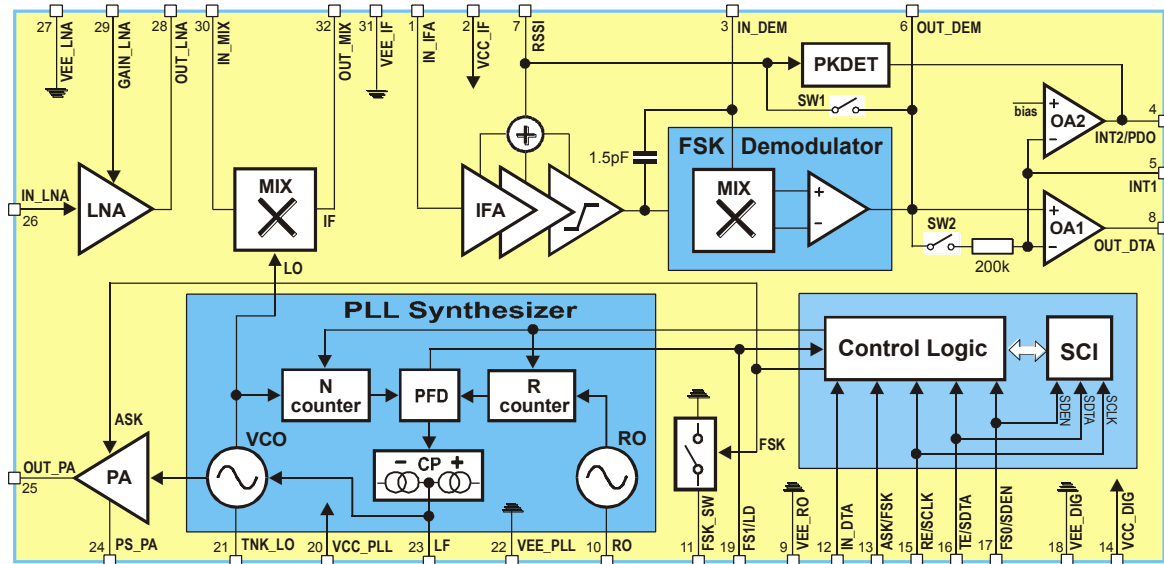

Fig. 1: TH7122 block diagram

1.5 User Mode Features

The transceiver can operate in two different user modes. It can be used either as a 3-wire-bus-controlled programmable or as a stand-alone fixed-frequency device. After power up, the transceiver is set to Stand-alone User Mode (SUM). In this mode, pins FS0/SDEN and FS1/LD must be connected to V_{EE} or V_{CC} in order to set the desired frequency of operation. There are 4 pre-defined frequency settings: 315MHz, 433.92MHz, 868.3MHz and 915MHz. The logic level at pin FS0/SDEN must not be changed after power up in order to remain in fixed-frequency mode.

After the first logic level change at pin FS0/SDEN, the transceiver enters into Programmable User Mode (PUM). In this mode, the user can set any PLL frequency or mode of operation by the SCI. In SUM pins FS0/SDEN and FS1/LD are used to set the desired frequency, while in PUM pin FS0/SDEN is part of the 3-wire serial control interface (SCI) and pin FS1/LD is the look detector output signal of the PLL synthesizer.

A mode control logic allows several operating modes. In addition to standby, transmit and receive mode, two idle modes can be selected to run either the reference oscillator only or the whole PLL synthesizer. The PLL settings for the PLL idle mode are taken over from the last operating mode which can be either receive or transmit mode.

The different operating modes can be set in SUM and PUM as well. In SUM the user can program the transceiver via control pins RE/SCLK and TE/SDTA. In PUM the register bits OPMODE are used to select the modes of operation while pins RE/SCLK and TE/SDTA are part of the SCI.

2 Pin Definitions and Descriptions

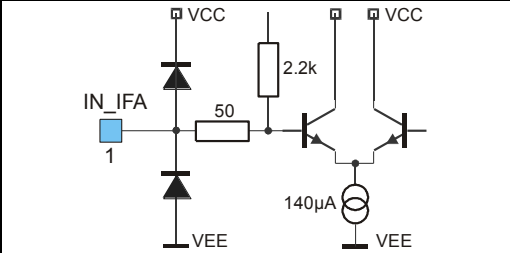
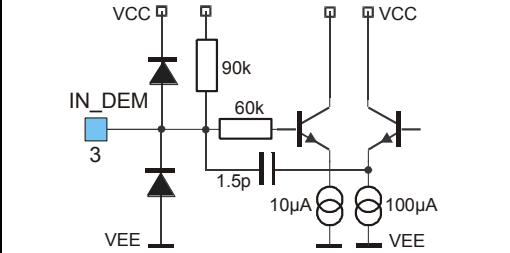
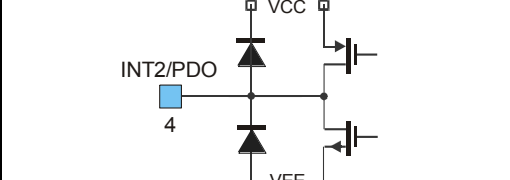
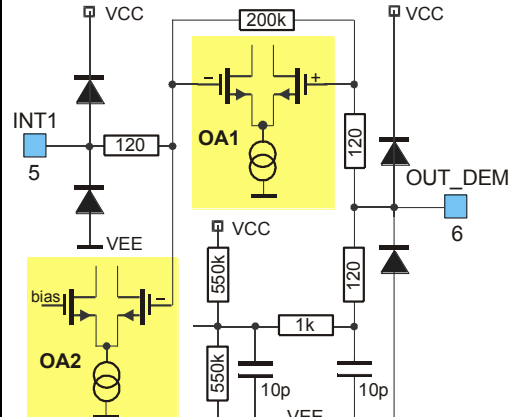
Pin No.	Name	I/O Type	Functional Schematic	Description
1	IN_IFA	input		IF amplifier input, approx. 2 kΩ single-ended
2	VCC_IF	supply		positive supply of LNA, MIX, IFA, FSK Demodulator, PA, OA1 and OA2
3	IN_DEM	analog I/O		IF amplifier output and demodulator input, connection to external ceramic discriminator or LC tank
4	INT2/PDO	output		OA2 output or peak detector output, high impedance in transmit and idle mode
5	INT1	input		inverting inputs of OA1 and OA2
6	OUT_DEM	analog I/O		demodulator output and non-inverting OA1 input, high impedance in transmit and idle mode

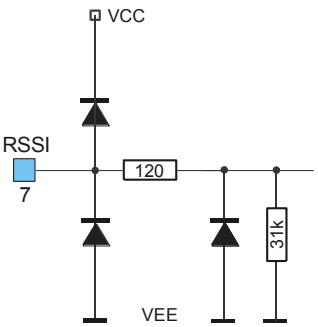
Pin No.	Name	I/O Type	Functional Schematic	Description
7	RSSI	output		RSSI output, approx. 31 kΩ

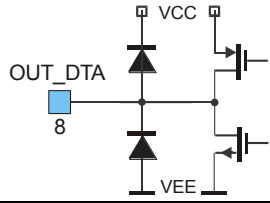
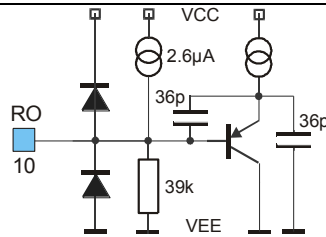
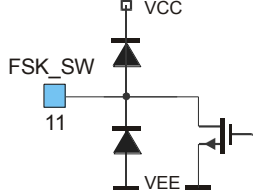
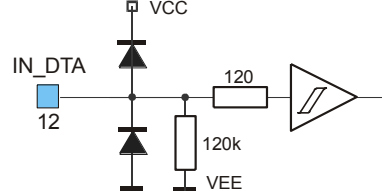
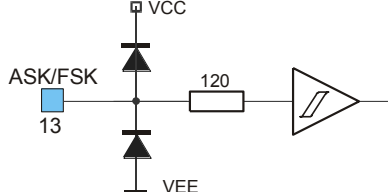
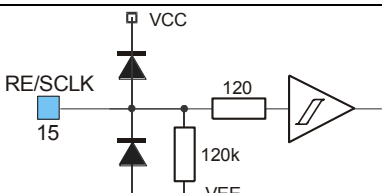
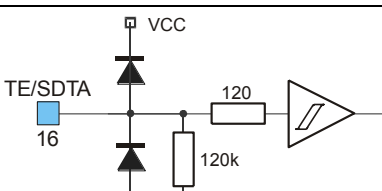
Pin No.	Name	I/O Type	Functional Schematic	Description
8	OUT_DTA	output		OA1 output, high impedance in transmit and idle mode
9	VEE_RO	ground		ground of RO
10	RO	analog I/O		RO input, base of bipolar transistor
11	FSK_SW	analog I/O		FSK pulling pin, switch to ground or OPEN The switch is open in receive and idle mode
12	IN_DTA	input		ASK/FSK modulation data input, pull down resistor 120kΩ
13	ASK/FSK	input		ASK/FSK mode select input
14	VCC_DIG	supply		positive supply of serial port and control logic
15	RE/SCLK	input		receiver enable input / clock input for the shift register, pull down resistor 120kΩ
16	TE/SDTA	input		transmitter enable input / serial data input, pull down resistor 120kΩ

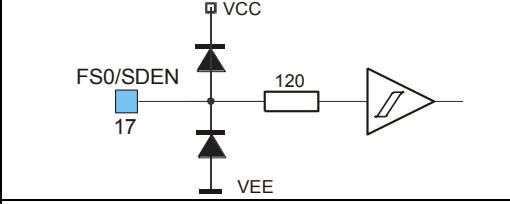
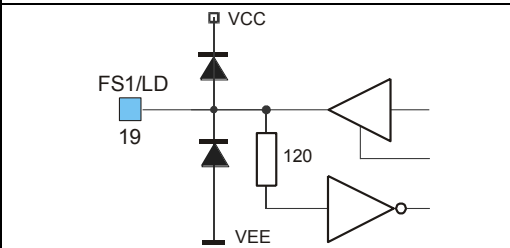
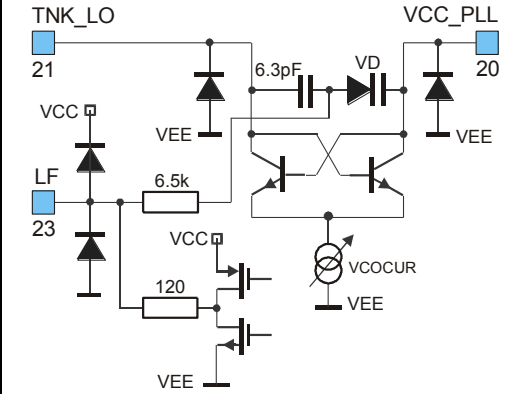
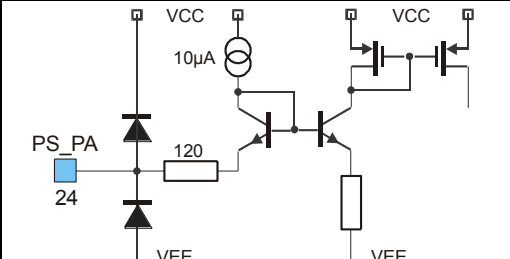
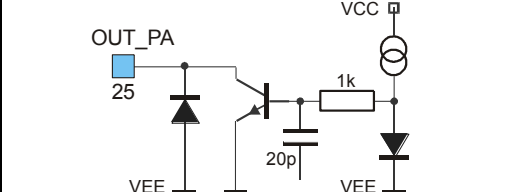
Pin No.	Name	I/O Type	Functional Schematic	Description
17	FS0/SDEN	input		frequency select input / serial data enable input
18	VEE_DIG	ground		ground of serial port and control logic
19	FS1/LD	input / output		frequency select input / lock detector output
20	VCC_PLL	analog I/O		VCO open-collector output, connection to VCC or external LC tank
21	TNK_LO	analog I/O		VCO open-collector output, connection to external LC tank
23	LF	analog I/O		charge pump output, connection to external loop filter
22	VEE_PLL	ground		ground of PLL frequency synthesizer
24	PS_PA	analog I/O		power-setting input
25	OUT_PA	output		power amplifier open-collector output

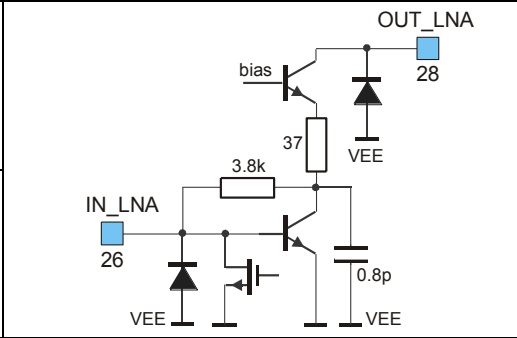
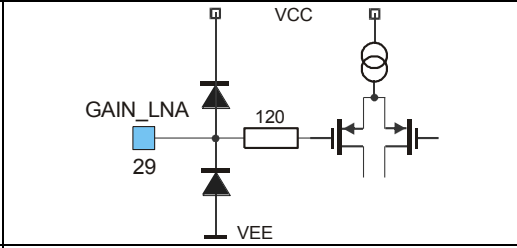
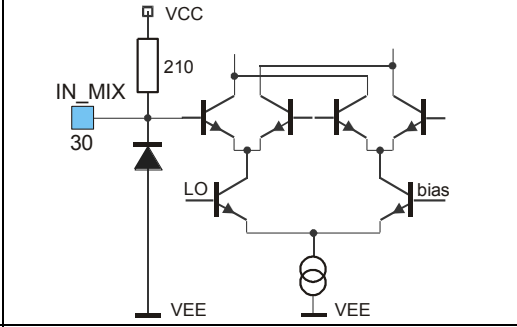
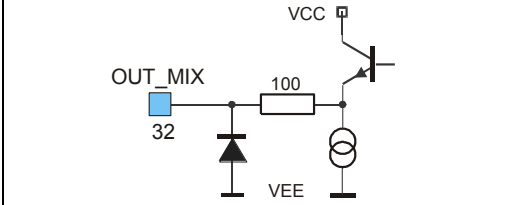
Pin No.	Name	I/O Type	Functional Schematic	Description
27	VEE_LNA	ground		ground of LNA and PA
28	OUT_LNA	output		LNA open-collector output, connection to external LC tank at RF
26	IN_LNA	input		LNA input, single-ended
29	GAIN_LNA	input		LNA gain control input
30	IN_MIX	input		mixer input, approx. 200Ω single-ended
31	VEE_IF	ground		ground of IFA, Demodulator, OA1 and OA2
32	OUT_MIX	output		mixer output, approx. 330Ω single-ended

3 Functional Description

3.1 PLL Frequency Synthesizer

The TH7122 contains an integer-N PLL frequency synthesizer. A PLL circuit performs the frequency synthesis via a feedback mechanism. The output frequency f_{VCO} is generated as an integer multiple of the phase detector comparison frequency f_R . This reference frequency f_R is generated by dividing the output frequency f_{RO} of a crystal oscillator. The phase detector utilizes this signal as a reference to tune the VCO and in the locked state it must be equal to the desired output frequency, divided by the feedback divider ratio N .

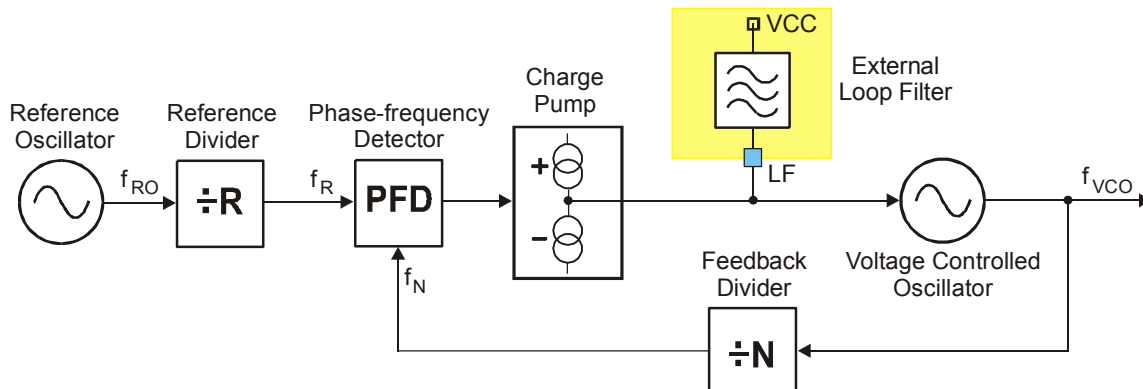

Fig. 2: Integer-N PLL Frequency Synthesizer Topology

The output frequency of the synthesizer f_{VCO} can be selected by programming the feedback divider and the reference divider. The only constraint for the frequency output of the system is that the minimum frequency resolution, or the channel spacing, must be equal to the PFD frequency f_R , which is given by the reference frequency f_{RO} and the reference divider factor R :

$$f_R = \frac{f_{RO}}{R} \quad (1)$$

When the PLL is unlocked (e.g. during power up or during reprogramming of a new feedback divider ratio N), the phase-frequency detector PFD and the charge pump create an error signal proportional to the phase difference of the two input signals. This error signal is low-pass filtered through the external loop filter and input to the VCO to control its frequency. A very low frequency resolution increases the settling time of the PLL and reduces the ability to cancel out VCO perturbations, because the loop filter is updated every $1/f_R$. After the PLL has locked, the VCO frequency is given by the following equation:

$$f_{VCO} = N \cdot \frac{f_{RO}}{R} = N \cdot f_R \quad (2)$$

There are four registers available to set the VCO frequencies in receive (registers RR and NR) and in transmit mode (registers RT and NT). These registers can be programmed using the Serial Control Interface in Programmable User Mode (PUM). In case of Stand-alone User Mode (SUM), the registers are set fixed values (refer to para. 4.1.1).

The VCO frequency is equal to the carrier frequency in transmit mode. While in receive mode the VCO frequency is offset by the intermediate frequency IF. This is because of the super-heterodyne nature of the receive part.

3.1.1 Reference Oscillator (XOSC)

The reference oscillator is based on a Colpitts topology with two integrated functional capacitors as shown in figure 3. The circuitry is optimized for a load capacitance range of 10 pF to 15 pF. The equivalent input capacitance C_{RO} offered by the oscillator input pin RO is about 18pF.

To ensure a fast and reliable start-up and a very stable frequency over the specified supply voltage and temperature range, the oscillator bias circuitry provides an amplitude regulation. The amplitude on pin RO is monitored in order to regulate the current of the oscillator core I_{RO} . There are two limits ROMAX and ROMIN between the regulation is maintained. These values can be changed via serial control interface in Programmable User Mode (PUM). In Stand-alone User Mode (SUM), ROMAX and ROMIN are set to default values (refer to para. 5.1.3). ROMAX defines the start-up current of the oscillator. The ROMIN value sets the desired steady-state current. If ROMIN is sufficient to achieve an amplitude of about 400 mV on pin RO, the current I_{RO} will be set to ROMIN. Otherwise the current will be permanently regulated between ROMIN and ROMAX. If ROMIN and ROMAX are equal, no regulation takes place. For most of the applications ROMIN and ROMAX should not be changed from default.

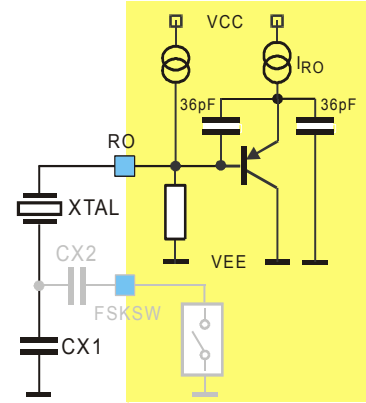

Fig. 3: Reference oscillator circuit

3.1.2 Reference Divider

The reference divider provides the input signal of the phase detector by dividing the signal of the reference oscillator. The range of the reference divider is

$$4 \leq R \leq 1023 \quad (3)$$

3.1.3 Feedback Divider

The feedback divider of the PLL is based on a pulse-swallow topology. It contains a 4-bit swallow A-counter, a 13-bit program B-counter and a prescaler. The divider ratio of the prescaler is controlled by the program counter and the swallow counter. During one cycle, the prescaler divides by 17 until the swallow A-counter reaches its terminal count. Afterwards the prescaler divides by 16 until the program counter reaches its terminal count. Therefore the overall feedback divider ratio can be expressed as:

$$N = 17 \cdot A + 16 \cdot (B - A) \quad (4)$$

The A-counter configuration represents the lower bits in the feedback divider register ($N_{0-3} = A_{0-3}$) and the upper bits the B-counter configuration ($N_{4-16} = B_{0-12}$) respectively. According to that, the following counter ranges are implemented:

$$0 \leq A \leq 15; \quad 4 \leq B \leq 8191 \quad \text{whereas } B > A \quad (5)$$

and therefore the range of the overall feedback divider ratio results in:

$$64 \leq N \leq 131071 \quad (6)$$

The user does not need to care about the A- and B-counter settings. It is only necessary to know the overall feedback divider ratio N to program the register settings.

3.1.4 Frequency Resolution and Operating Frequency

It is obvious from (2) that, at a given frequency resolution f_R , the maximum operating frequency of the VCO is limited by the maximum N-counter setting. The table below provides some illustrative numbers. Please also refer to section 4.4.1 for the pre-configured settings in Stand-alone User Mode (SUM).

Crystal frequency f_{RO}	Frequency resolution f_R	R counter	N counter	Operating frequency f_{VCO}
3.0000MHz	2.93kHz	1023	13107	38.437MHz
3.0000MHz	2.93kHz	1023	131071	384.372MHz
8.0000MHz	12.5kHz	640	35812	447.65MHz
8.0000MHz	25kHz	320	34746	868.65MHz
8.0000MHz	250kHz	32	3660	915.0MHz

3.1.5 Phase-Frequency Detector

The phase-frequency detector creates an error voltage proportional to the phase difference between the reference signal f_R and f_N . The implementation of the phase detector is a phase-frequency type. That circuitry is very useful because it decreases the acquisition time significantly. The gain of the phase detector can be expressed as:

$$K_{PD} = \frac{I_{CP}}{2\pi}, \quad (7)$$

where I_{CP} is the charge pump current which is set via register CPCUR. In the TH7122 design the VCO frequency control characteristic is with negative polarity. This means the VCO frequency increases if the loop filter output voltage decreases and vice versa. When an external varactor diode is added to the VCO tank, the tuning characteristic can be changed between positive and negative depending on the particular varactor diode circuitry. Therefore the PDFPOL register can be used to define the phase detector polarity.

3.1.6 Lock Detector

In Programmable User Mode a lock-detect signal LD is available at pin FS1/LD (pin 19). The lock detection circuitry uses Up and Down signals from the phase detector to check them for phase coherency. Figure 4 shows an overview of the lock signal generation. The locked state and the unlock condition will be decided on the register settings of LDTM and ERTM respectively. In the start-up phase of the PLL, Up and Down signals are quite unbalanced and counter CNT_LD receives no clock signal. When the loop approaches steady state, the signals Up and Down begin to overlap and CNT_LD counts down. Herein register LDTM sets the number of counts which are necessary to set the lock detection signal LD. If an unlock condition occurs, the counter CNT_LD will be reloaded and therefore its CARRY falls back.

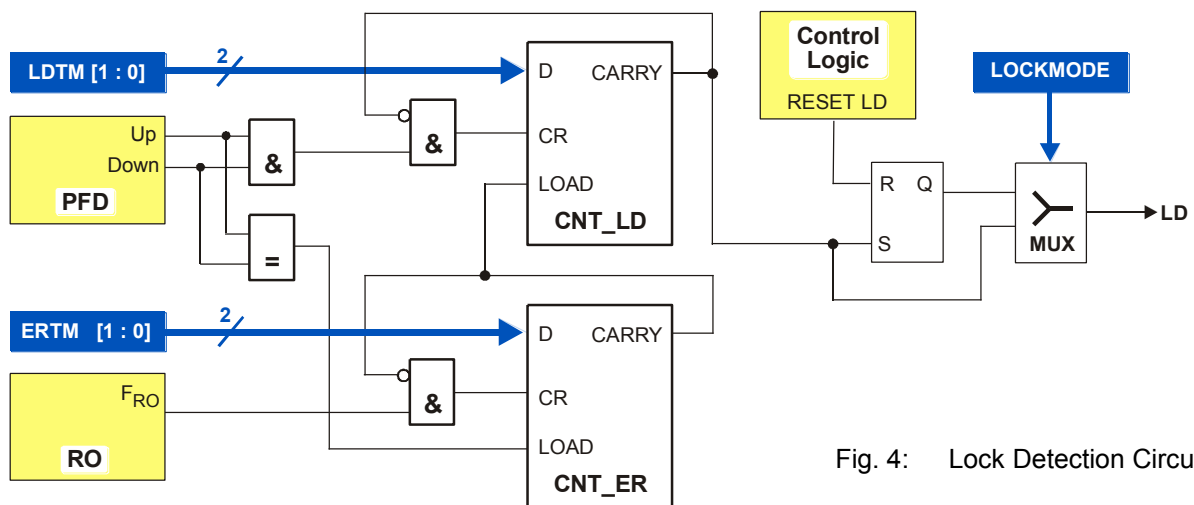

Fig. 4: Lock Detection Circuit

The CNT_ER supervises the unlock condition. If Up and Down are consecutive, the counter CNT_ER will be reloaded permanently and its CARRY will not be set, otherwise the counter level of CNT_ER will be reduced by the reference oscillator clock ($1/f_{RO}$). The register ERTM decides on the maximum number of clocks during Up and Down signals can be non-consecutive without losing the locked state. The transceiver offers two ways of analyzing the locked state. If the register LOCKMODE is set to '0', only one occurrence of the locked state condition is needed to remain LD = 1 during the whole active mode, otherwise the state of the PLL will be observed permanently.

3.1.7 Voltage Controlled Oscillator with external Loop Filter

The transceiver provides a LC-based voltage-controlled oscillator with an external inductance element connected between VCC and pin TNK_LO. An internal varactor diode in series with a fixed capacitor forms the variable part of the oscillator tank. The oscillation frequency is adjusted by the DC-voltage at pin LF. The tuning sensitivity of the VCO is approximately 20MHz/V for 433MHz operations and 40MHz/V at 868MHz. Since the internal varactor is connected to VCC, a lower voltage on pin LF causes the capacitance to decrease and the VCO frequency to increase. For this reason the phase detector polarity should be negative (PFDPOL = 0). If the operation frequency is below 300MHz, an external varactor diode between pin TNK_LO and VCC_PLL is necessary. The corresponding application schematic is shown in section 8. The VCO current VCOCUR can be adjusted via serial control interface in order to ensure stable oscillations over the whole frequency range. For lowest LO emission in receive mode, VCOCUR should be set to the lowest value.

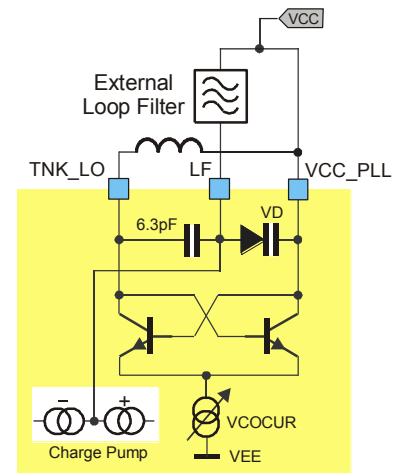

Fig. 5: VCO schematic

3.1.8 Loop Filter

Since the loop filter has a strong impact on the function of the PLL, it must be chosen carefully. For FSK operation the bandwidth of the loop filter must be selected wide enough for a fast relock of the PLL during crystal pulling. The bandwidth must of course also be larger than the data rate. In case of ASK or OOK the bandwidth should be extended even further to allow the PLL to cancel out VCO perturbations that might be caused by the PA on/off keying. The suggested filter topology is shown in Fig. 6. The dimensions of the loop filter elements can be derived using well known formulas in application notes and other reference literature.

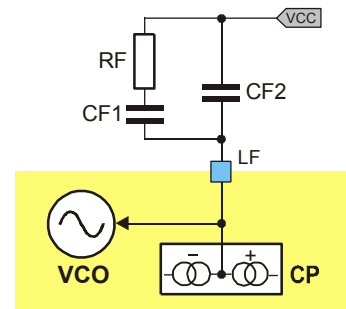

Fig. 6: 2nd order Loop filter

3.2 Receiver Part

The RF front-end of the receiver part is a super-heterodyne configuration that converts the input radio-frequency (RF) signal into an intermediate frequency (IF) signal. The most commonly used IF is 10.7 MHz, but IFs in the range of 0.4 to 22 MHz can also be used. According to the block diagram, the front-end consists of a LNA, a Mixer and an IF limiting amplifier with received signal strength indicator (RSSI). The local oscillator (LO) signal for the mixer is generated by the PLL frequency synthesizer.

As the receiver constitutes a superhet architecture, there is no inherent suppression of the image frequency. It depends on the particular application and the system's environmental conditions whether an RF front-end filter should be added or not. If image rejection and/or good blocking immunity are relevant system parameters, a band-pass filter must be placed either in front or after the LNA. This filter can be a SAW (surface acoustic wave) or LC-based filter (e.g. helix type).

3.2.1 LNA

The LNA is based on a cascode topology for low-noise, high gain and good reverse isolation. The open collector output has to be connected to an external resonance circuit which is tuned to the receive frequency. The gain of the LNA can be changed in order to achieve a high dynamic range. There are two possibilities for the gain setting which can be selected by the register bit LNACTRL. External control can be done via the pin GAIN_LNA, internal control is given by the register bit LNAGAIN. In case of external gain control, a hysteresis of about 340 mV can be chosen via the register bit LNAHYST. This configuration is useful if an automatic gain control loop via the RSSI signal is established. In transmit mode the LNA-input is shorted to protect the amplifier from saturation and damaging.

3.2.2 Mixer

The mixer is a double-balanced mixer which down converts the receive frequency to the IF. The default LO injection type is low side ($f_{VCO} = f_{RX} - f_{IF}$). But also high side injection is possible ($f_{VCO} = f_{RX} + f_{IF}$). In this case, the data signal's polarity is inverted due to the mixing process. To avoid this, the transmitted data stream can be inverted too by setting DTAPOL to '1'.

The output impedance of the mixer is about 330Ω in order to match to an external IF filter.

3.2.3 IF Amplifier

After passing the channel select filter which sets the IF bandwidth the signal is limited by means of an high gain limiting amplifier. The small signal gain is about 80 dB. The RSSI signal is generated within the IF amplifier. The output of the RSSI signal is available at pin RSSI. The voltage at this pin is proportional to the input power of the receiver in dBm. Using this RSSI output signal the signal strength of different transmitters can be distinguished.

3.2.4 ASK Demodulator

The receive part of the TH7122 allows for two ASK demodulation configurations:

- standard ASK demodulation or
- ASK demodulation with peak detector.

The default setting is standard ASK demodulation. In this mode SW1 and SW2 are closed and the RSSI output signal directly feeds the data slicer setup by means of OA1. The data slicer time constant equals to

$$T = 200k\Omega \cdot C3, \quad (8)$$

with C3 external to pin INT1. This time constant should be larger than the longest possible bit duration of the data stream. This is required to properly extract the ASK data's DC level. The purpose of the DC (or mean) level at the negative input of OA1 is to set an adaptive comparator threshold to perform the ASK detection.

Alternatively a peak detector can be used to define the ASK detection threshold. In this configuration the peak detector PKDET is enabled, SW1 is closed and SW2 is open, and the peak detector output is multiplexed to pin INT2/PDO. This way the peak detector can feed the data slicer, again constituted by OA1 and a few external R and C components. The peak detection mode is selectable in programmable user mode.

3.2.5 FSK Demodulator

The implemented FSK demodulator is based on the phase-coincidence principle. A discriminator tank, which can either consist of a ceramic discriminator or an LC tank, is connected to pin IN_DEM. If FSK mode is selected SW1 is open, SW2 is closed and the output of OA2 is multiplexed to pin INT2/PDO.

The demodulator output signal directly feeds the data slicer setup by means of OA1. The data slicer time constant can be calculated using (8). This time constant should be larger than the longest possible bit duration of the data stream as described in the previous paragraph.

An on-chip AFC circuit tolerates input frequency variations. The input frequency acceptance range is proportional to the FSK or FM deviation. It can be adjusted by the discriminator tank. The AFC feature is disabled by default and can be activated in programmable mode.

3.3 Transmitter Part

The output of the PLL frequency synthesizer feeds a power amplifier (PA) in order to setup a complete RF transmitter. The VCO frequency is identical to the carrier frequency.

3.3.1 Power Amplifier

The power amplifier (PA) has been designed to deliver about 10 dBm in the specified frequency bands. Its pin OUT_PA is an open collector output. The larger the output voltage swing can be made the better the power efficiency will be. The PA must be matched to deliver the best efficiency in terms of output power and current consumption.

The collector must be biased to the positive supply. This is done by means of an inductor parallel tuned with a capacitor. Or it is made large enough in order not to affect the output matching network. S-parameters of pin OUT_PA are not useful because the output is very high resistive with a small portion of parallel capacitance. Since the open-collector output transistor can be considered as a current source, the only parameters needed to design the output matching network are the output capacitance, the supply voltage V_{CC} , the transistor's saturation voltage and the power delivered to the load P_O .

In order to avoid saturation of the output stage, a saturation voltage $V_{CE_{SAT}}$ of about 0.7 V should be considered. The real part of the load impedance can then be calculated using

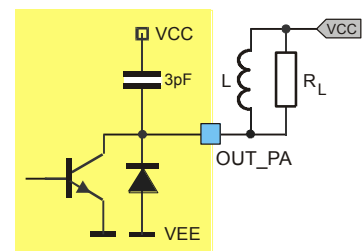

Fig. 7: OUT_PA schematic

$$R_L = \frac{(V_{CC} - V_{CE_{SAT}})^2}{2 \cdot P_O} \quad (9)$$

The output capacitance is typically 3 pF.

3.3.2 Output Power Adjustment

The maximum output power is adjustable via the external resistor RPS as shown in Figure 8. There are four predefined power settings in programmable user mode which can be set in the register TXPOWER. The maximum power setting P4 is the default setting.

Fig. 8: Output power vs. RPS

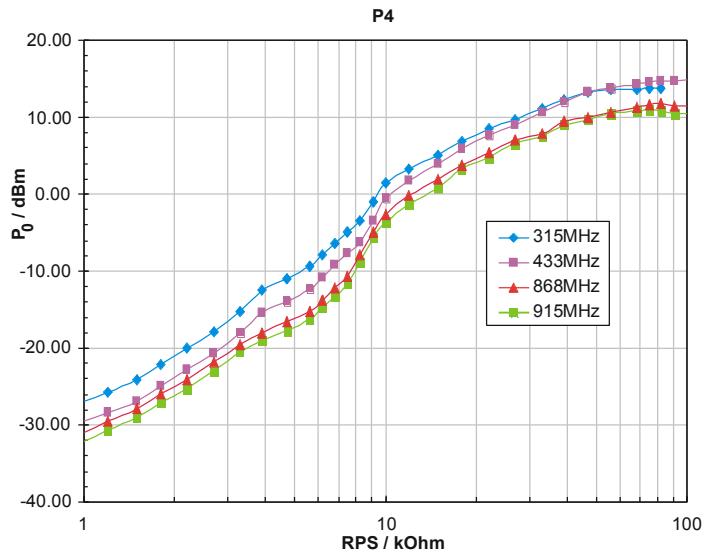

3.3.3 Modulation Schemes

The RF carrier generated by the PLL frequency synthesizer can be ASK or FSK modulated. Depending on the selected user mode, the modulation type can be selected either by the ASK/FSK pin or via the serial control interface. Data is applied to pin IN_DTA. The data signal can be inverted by the bit DTAPOL. The following tables for ASK and FSK modulation are valid for non-inverted data (DTAPOL = 0)

3.3.4 ASK Modulation

IN_DTA	Description
0	Power amplifier is turned off
1	Power amplifier is turned on (according to the selected output power)

The transceiver is ASK-modulated by turning on and off the power amplifier. Please also refer to para. 1.3 for ASK modulation limits.

3.3.5 FSK Modulation

- FSK modulation via crystal pulling

FSK modulation can be achieved by pulling the crystal oscillator frequency. A CMOS-compatible data stream applied at pin IN_DTA digitally modulates the XOSC via an integrated NMOS switch. Two external pulling capacitors CX1 and CX2 allow the FSK deviation Δf and center frequency f_c to be adjusted independently. At IN_DTA = LOW CX2 is connected in parallel to CX1 leading to the low-frequency component of the FSK spectrum (f_{min}); while at IN_DTA = HIGH CX2 is deactivated and the XOSC is set to its high frequency, leading to f_{max} .

IN_DTA	Description
0	$f_{min} = f_c - \Delta f$ (FSK switch is closed)
1	$f_{max} = f_c + \Delta f$ (FSK switch is open)

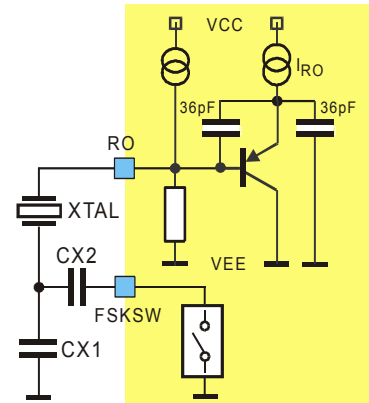

Fig. 9: Crystal Pulling Circuit

An external reference signal can be directly AC-coupled to the reference oscillator input pin RO. Then the transceiver is used without a XTAL. Now the reference signal sets the carrier frequency and has to contain the FSK (or FM) modulation

- FSK modulation via direct VCO modulation

Alternatively FSK or FM can be achieved by injecting the modulating signal into the loop filter to directly control the VCO frequency. Fig. 10 shows a circuit proposal for direct VCO modulation. This circuit is recommended for data rates in excess of about 20 kbps NRZ. An external VCO tuning varactor should be added for narrow-band applications, for example at channel spacings of 25 kHz. For details please refer to the application notes "TH7122 and TH71221 High Speed Data Communication" and "TH7122 and TH71221 Used In Narrow Band FSK Applications" as well as to the "TH7122 and TH71221 Cookbook"

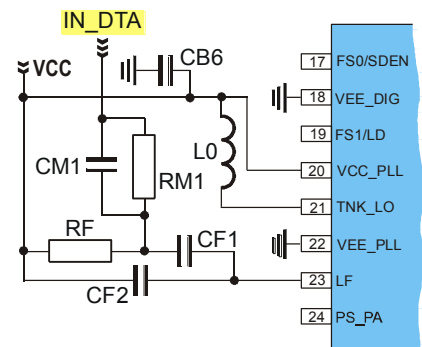

Fig. 10: Circuit schematic for direct VCO modulation

3.3.6 Crystal Tuning

A crystal is tuned by the manufacturer to the requested oscillation frequency f_0 for a certain load capacitance CL within the specified calibration tolerance. The only way to tune this oscillation frequency is to vary the effective load capacitance CL_{eff} seen by the crystal.

Figure 8 shows the oscillation frequency of a crystal in dependency on the effective load capacitance. This capacitance changes in accordance with the logic level of IN_DTA around the specified load capacitance. The figure illustrates the relationship between the external pulling capacitors and the frequency deviation.

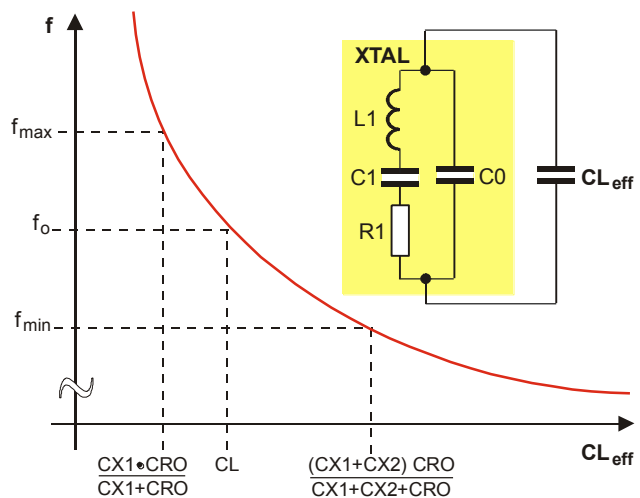

Fig. 11: Crystal Tuning Characteristic

4 Description of User Modes

4.1 Stand-alone User Mode Operation

After power up the transceiver is set to stand-alone user mode. In this mode, pins FS0/SDEN and FS1/LD must be connected to V_{EE} or V_{CC} to set the desired frequency of operation. The logic level at pin FS0/SDEN must not be changed after power up in order to remain in stand-alone user mode. The default settings of the control word bits in stand-alone user mode are described in the frequency selection table. Detailed information about the default settings can be found in the tables of section 5.

4.1.1 Frequency Selection

Channel frequency	433.92 MHz	868.3 MHz	315 MHz	915 MHz
FS0/SDEN	1	0	1	0
FS1/LD	0	0	1	1
Reference oscillator frequency				
	7.1505 MHz			
R counter ratio in RX mode (RR)	32	16	18	32
PFD frequency in RX mode	223.45 kHz	446.91 kHz	397.25 kHz	223.45 kHz
N counter ratio in RX mode (NR)	1894	1919	766	4047
VCO frequency in RX mode	423.22 MHz	857.60 MHz	304.30 MHz	904.30 MHz
RX frequency	433.92 MHz	868.30 MHz	315.00 MHz	915.00 MHz
R counter ratio in TX mode (RT)	32	16	18	32
PFD frequency in TX mode	223.45 kHz	446.91 kHz	397.25 kHz	223.45 kHz
N counter ratio in TX mode (NT)	1942	1943	793	4095
VCO frequency in TX mode	433.92 MHz	868.30 MHz	315.00 MHz	915.00 MHz
TX frequency	433.92 MHz	868.30 MHz	315.00 MHz	915.00 MHz
IF in RX mode	10.7 MHz	10.7 MHz	10.7 MHz	10.7 MHz

In stand-alone user mode, the transceiver can be set to Standby, Receive, Transmit or Idle mode (only PLL synthesizer active) via control pins RE/SCLK and TE/SDTA. The modulation scheme and the LNA gain are set by pins ASK/FSK and GAIN_LNA, respectively.

4.1.2 Operation Mode

Operation mode	Standby	Receive	Transmit	Idle
RE/SCLK	0	1	0	1
TE/SDTA	0	0	1	1

Note: Pins with internal pull-down

4.1.3 Modulation Type

Modulation type	ASK	FSK
ASK / FSK	0	1

4.1.4 LNA Gain Mode

LNA gain	high	low
GAIN_LNA	0	1

4.2 Programmable User Mode Operation

The transceiver can also be used in programmable user mode. After power-up the first logic change at pin FS0/SDEN enters into this mode. Now full programmability can be achieved via the Serial Control Interface (SCI).

4.2.1 Serial Control Interface Description

A 3-wire (SCLK, SDTA, SDEN) Serial Control Interface (SCI) is used to program the transceiver in programmable user mode. At each rising edge of the SCLK signal, the logic value on the SDTA pin is written into a 24-bit shift register. The data stored in the shift register are loaded into one of the 4 appropriate latches on the rising edge of SDEN. The control words are 24 bits lengths: 2 address bits and 22 data bits. The first two bits (bit 23 and 22) are latch address bits. As additional leading bits are ignored, only the least significant 24 bits are serial-clocked into the shift register. The first incoming bit is the most significant bit (MSB). To program the transceiver in multi-channel application, four 24-bit words may be sent: A-word, B-word, C-word and D-word. If individual bits within a word have to be changed, then it is sufficient to program only the appropriate 24-bit word. The serial data input timing and the structure of the control words are illustrated in Fig. 12 and 13.

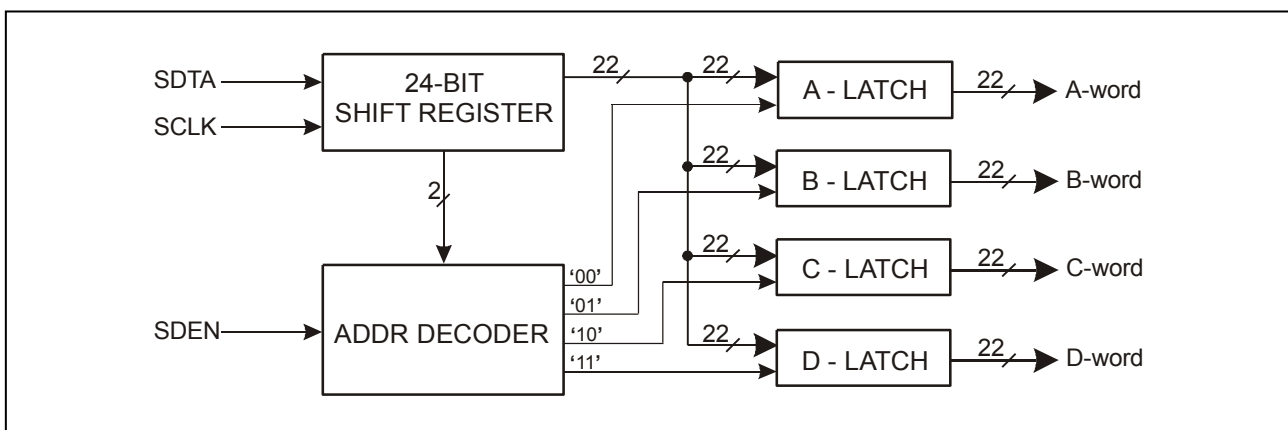

Fig. 12: SCI Block Diagram

Due to the static CMOS design, the SCI consumes virtually no current and it can be programmed in active as well as in standby mode.

If the transceiver is set from standby mode to any of the active modes (idle, receive, transmit), the SCI settings remain the same as previously set in one of the active modes, unless new settings are done on the SCI while entering into an active mode.

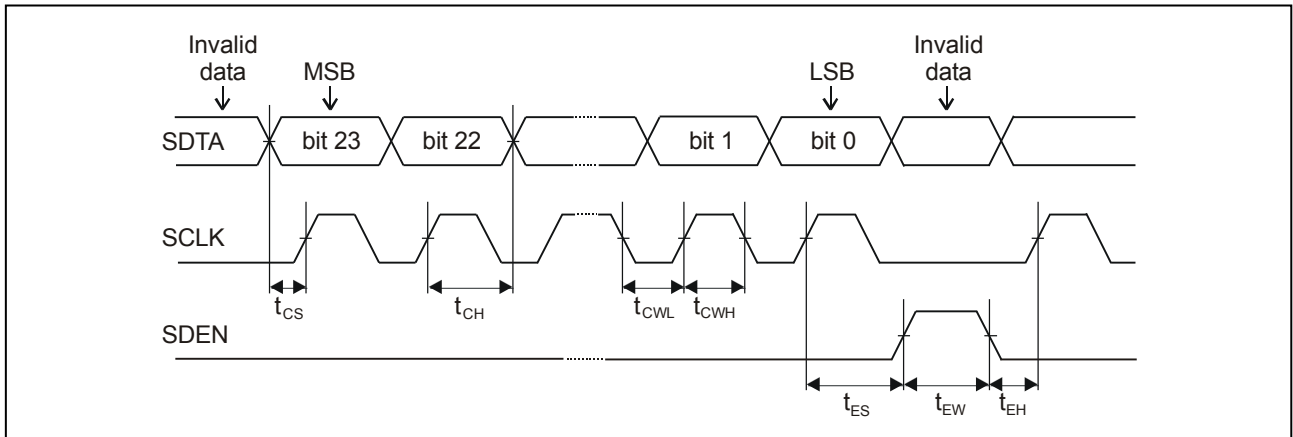

Fig. 13: Serial Data Input Timing

5 Register Description

As shown in the previous section there are four control words which stipulate the operation of the whole chip. In Stand-alone User Mode SUM the intrinsic default values with respect to the applied levels at pins FS0 and FS1 lay down the configuration of the transceiver. In Programmable User Mode (PUM) the register settings can be changed via 3-wire interface SCI. The default settings which vary with the desired operating frequency depend on the voltage levels at the frequency selection pins FS0 and FS1 before entering the PUM. Table 5.1.1 shows the default register settings of different frequency selections. It should be noted that the channel frequency listed below will be achieved with a crystal frequency of 7.1505 MHz. The following table depicts an overview of the register configuration of the TH7122.

5.1 Register Overview

WORD		DATA																							
MSB																		LSB							
23	22	21	20	19	18	17	16	15	14	13	12	11	10	9	8	7	6	5	4	3	2	1	0	Bit No.	
0	0	0	0	0	0	0	1	1	1	1	1	0	0	Depends on FS0/FS1 voltage level after power up									default		
A		IDLE	DATAPOL	MODSEL	CPCUR	LOCKMODE	PACTRL	TXPOWER [1:0]		Set to 1	LNAGAIN	OPMODE [1:0]		RR [9:0]											
		23	22	21	20	19	18	17	16	15	14	13	12	11	10	9	8	7	6	5	4	3	2	1	0
0	1	0	1	1	1	0	0	1	1	1	0	1	0	Depends on FS0/FS1 voltage level after power up									default		
B		PKDET	Set to 1	DELPLL	LNAHYST	AFC	OA2	ROMAX [2:0]		ROMIN [2:0]		RT [9:0]													
		23	22	21	20	19	18	17	16	15	14	13	12	11	10	9	8	7	6	5	4	3	2	1	0
1	0	0	0	Depends on FS0/FS1 voltage level after power up																		default			
C		LNACTRL	PFDPOL	VCOCUR [1:0]		BAND	NR [16:0]																		
		23	22	21	20	19	18	17	16	15	14	13	12	11	10	9	8	7	6	5	4	3	2	1	0
1	1	0	0	1	0	0	Depends on FS0/FS1 voltage level after power up																		default
D		MODCTRL	LDTM [1:0]		ERTM [1:0]		NT [16:0]																		
		23	22	21	20	19	18	17	16	15	14	13	12	11	10	9	8	7	6	5	4	3	2	1	0

5.1.1 Default Register Settings for FS0, FS1

FS1	FS0	Channel frequency	BAND	VCOCUR [1:0]	RR [9:0]	NR [16:0]	RT [9:0]	NT [16:0]
0	0	868.30 MHz	1	11	16d	1919d	16d	1943d
0	1	433.92 MHz	0	01	32d	1894d	32d	1942d
1	0	915.00 MHz	1	11	32d	4047d	32d	4095d
1	1	315.00 MHz	0	00	18d	766d	18d	793d

Note: d – decimal code

A detailed description of the registers function and their configuration can be found in the following sections.

5.1.2 A – word

Name	Bits	Description
RR	[9:0]	Reference divider ratio in RX operation mode
		4d .. 1023d
OPMODE	[11:10]	Operation mode
		00 Standby mode #default
		01 Receive mode
		10 Transmit mode
		11 Idle mode
LNAGAIN	[12]	LNA gain
		0 low LNA gain
		1 high LNA gain #default
		This selection is valid if bit LNACTR (bit 21 in C-word) is set to internal LNA gain control.
not used	[13]	set to '1' for correct function
TXPOWER	[15:14]	Output power steps
		00 P1
		01 P2
		10 P3
		11 P4 #default
PACTRL	[16]	Set the PA-on condition
		0 PA is switched on if the PLL locks
		1 PA is always on in TX mode #default
LOCKMODE	[17]	Set the PLL locked state observation mode
		0 before lock only #default
		Locked state condition will be ascertained only one time afterwards the LD signal remains in high state.
		1 before and after lock
		locked state will be observed permanently
CPCUR	[18]	Charge Pump output current
		0 260 μ A
		1 1300 μ A #default
MODSEL	[19]	Modulation mode
		0 ASK #default
		1 FSK
		This selection is valid if bit MODCTRL (bit 21 in D-word) is set to internal modulation control.
DTAPOL	[20]	Input data polarity
		0 normal #default
		'0' for space at ASK or f_{min} at FSK, '1' for mark at ASK or f_{max} at FSK
		1 inverse
		'1' for space at ASK or f_{min} at FSK, '0' for mark at ASK or f_{max} at FSK
IDLESEL	[21]	Active blocks in IDLE mode
		0 only RO active
		1 whole PLL active #default

5.1.3 B – word

Name	Bits	Description		
RT	[9:0]	Reference divider ratio in TX operation mode		
		4d .. 1023d		
ROMIN	[12:10]	Set the desired steady state current of the reference oscillator		
		000	0 μ A	<p>The control circuitry regulates the current of the oscillator core between the values ROMAX and ROMIN. As the regulation input signal the amplitude on pin RO is used. If the ROMIN value is sufficient to achieve an amplitude of about 400mV on pin RO the current of the reference oscillator core will be set to ROMIN. Otherwise the current will be permanently regulated between ROMAX and ROMIN. If ROMIN and ROMAX are equal no regulation of the oscillator current occurs. Please also note the block description of the reference oscillator in para. 3.1.1</p>
		001	75 μ A	
		010	150 μ A	
		011	225 μ A	
		100	300 μ A	
		101	375 μ A	
		110	450 μ A	
		111	525 μ A	
		#default		
ROMAX	[15:13]	Set the start-up current of the reference oscillator		
		000	0 μ A	<p>Set the start-up current of the reference oscillator core. Please also note the description of the ROMIN register and the block description of the reference oscillator which can be seen above.</p>
		001	75 μ A	
		010	150 μ A	
		011	225 μ A	
		100	300 μ A	
		101	375 μ A	
		110	450 μ A	
		111	525 μ A	
		#default		
OA2	[16]	OA2 operation		
		0	disabled	#default
		1	enabled	
OA2 can be enabled in FSK receive mode. OA2 is disabled in ASK mode receive.				
AFC	[17]	Internal AFC feature		
		0	disabled	#default
		1	enabled	
LNAHYST	[18]	Hysteresis on pin GAIN_LNA		
		0	disabled	#default
		1	enabled	
DELPLL	[19]	Delayed start of the PLL		
		0	undelayed start	PLL starts at the reference oscillator start-up
		1	starts after 8 valid RO-cycles	#default
PLL starts after 8 valid RO-cycles before entering an active mode to ensure reliable oscillation of the reference oscillator.				
not used	[20]	set to '1' for correct function		
PKDET	[21]	RSSI Peak Detector		
		0	disabled	#default
		1	enabled	
The RSSI output signal directly feeds the data slicer setup by means of OA1.				
In ASK receive mode the RSSI Peak Detector output is multiplexed to pin INT2/PDO.				

5.1.4 C – word

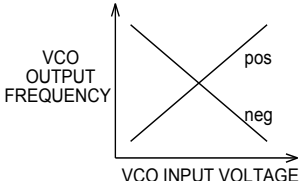
Name	Bits	Description	
NR	[16:0]	Feedback divider ratio in RX operation mode	
		64d .. 131071d	
BAND	[17]	Set the desired frequency range	
		0	recommended at $f_{RF} < 500$ MHz
		1	recommended at $f_{RF} > 500$ MHz
		Some tail current sources are linked to this bit in order to save current for low frequency operations.	
VCOCUR	[19:18]	VCO active current	
		00	low current (300 μA)
		01	standard current (500 μA)
		10	high1 current (700 μA)
		11	high2 current (900 μA)
PFDPOL	[20]	Phase Detector polarity	
		0	negative #default
		1	positive
			
LNACTRL	[21]	LNA gain control mode	
		0	external LNA gain control #default
		LNA gain will be set via pin GAIN_LNA.	
		1	internal LNA gain control
		LNA gain will be set via bit LNAGAIN (bit 12 in A-word). Nevertheless pin GAIN_LNA must be connected to either VCC or VEE.	