



Chipsmall Limited consists of a professional team with an average of over 10 year of expertise in the distribution of electronic components. Based in Hongkong, we have already established firm and mutual-benefit business relationships with customers from,Europe,America and south Asia,supplying obsolete and hard-to-find components to meet their specific needs.

With the principle of “Quality Parts,Customers Priority,Honest Operation,and Considerate Service”,our business mainly focus on the distribution of electronic components. Line cards we deal with include Microchip,ALPS,ROHM,Xilinx,Pulse,ON,Everlight and Freescale. Main products comprise IC,Modules,Potentiometer,IC Socket,Relay,Connector.Our parts cover such applications as commercial,industrial, and automotives areas.

We are looking forward to setting up business relationship with you and hope to provide you with the best service and solution. Let us make a better world for our industry!



Contact us

Tel: +86-755-8981 8866 Fax: +86-755-8427 6832

Email & Skype: info@chipsmall.com Web: www.chipsmall.com

Address: A1208, Overseas Decoration Building, #122 Zhenhua RD., Futian, Shenzhen, China



To Our Customers

CEL continues to offer industry leading semiconductor products from Japan. We are pleased to add new communication products from THine Electronics to our product portfolio.



THCV216

V-by-One® HS High-speed video data receiver

General Description

THCV216 is designed to support video data transmission between the host and display.

This chip can receive 39bit video data and 3bit control data via only a single differential cable at an LVDS clock frequency from 20MHz to 100MHz.

This chip, which has two high-speed data lanes, can transmit the video data up to 1080p/10b/60Hz, 1080p/12b/60Hz. The maximum serial data rate is 3.75Gbps/lane.

Color Depth	Link	LVDS Clock Frequency
6bit	Single/Dual	20MHz to 100MHz
8bit	Single/Dual	20MHz to 100MHz
10bit	Single/Dual	20MHz to 85MHz
12bit	Single/Dual	20MHz to 75MHz

Features

- Color depth selectable: 6/8/10/12 bit
- Single/Dual Link selectable
- AC coupling
- LVDS Input internal termination
- CORE 1.8v, LVDS 3.3v
- Package: 64 pin TSSOP
- Wide frequency range
- CDR requires no external frequency reference
- Supports Spread Spectrum Clocking: Up to 30kHz/±0.5%(center spread)
- V-by-One® HS standard Version1.3 compliant

Block Diagram

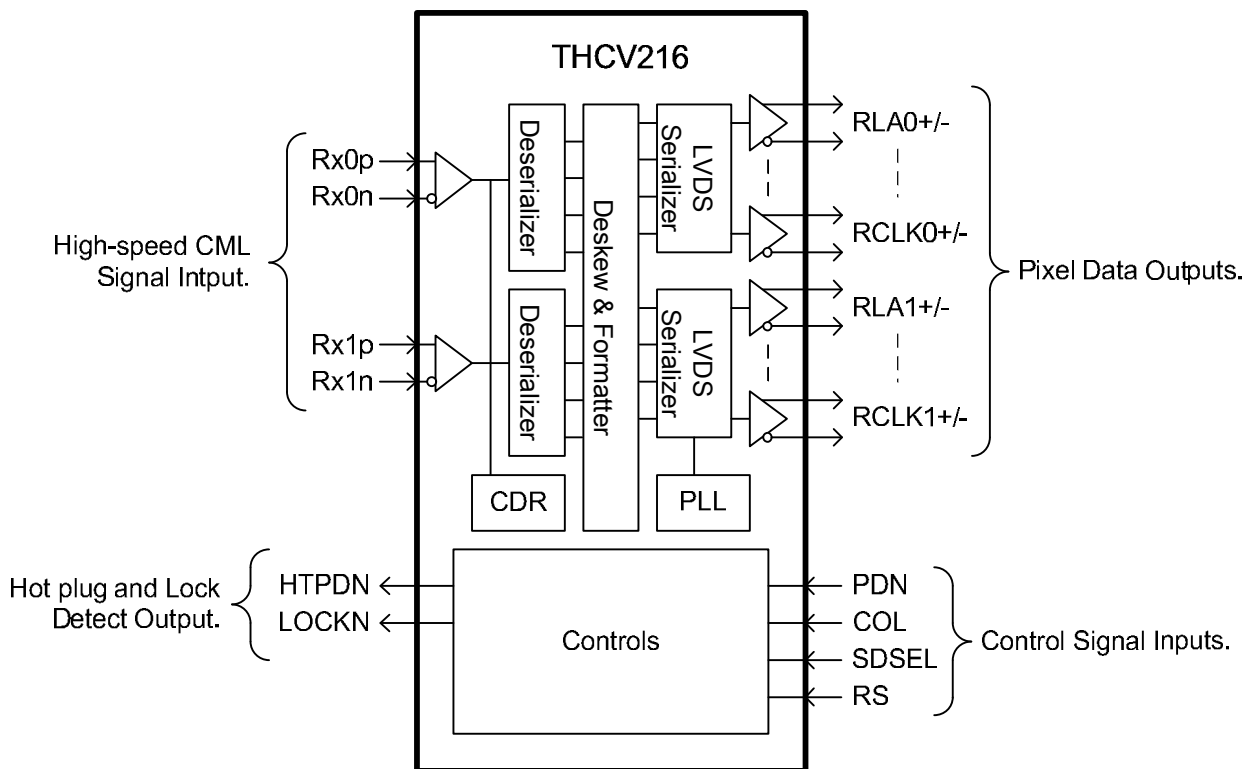

Example System Diagram

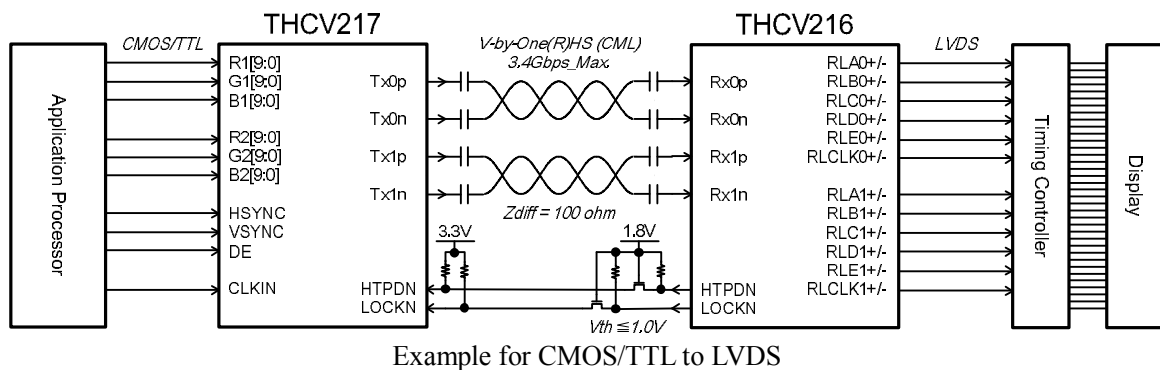
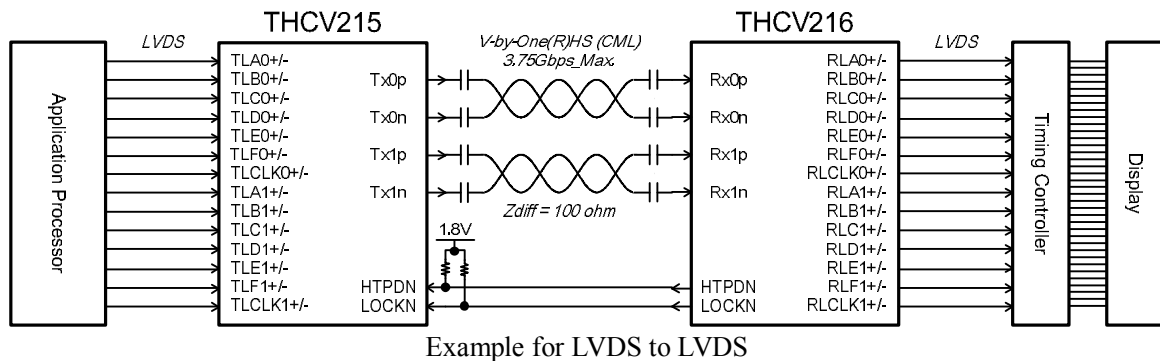

Notices and Requests

1. The product specifications described in this material are subject to change without prior notice.
2. The circuit diagrams described in this material are examples of the application which may not always apply to the customer's design. We are not responsible for possible errors and omissions in this material. Please note if errors or omissions should be found in this material, we may not be able to correct them immediately.
3. This material contains our copy right, know-how or other proprietary. Copying or disclosing to third parties the contents of this material without our prior permission is prohibited.
4. Note that if infringement of any third party's industrial ownership should occur by using this product, we will be exempted from the responsibility unless it directly relates to the production process or functions of the product.
5. This product is presumed to be used for general electric equipment, not for the applications which require very high reliability (including medical equipment directly concerning people's life, aerospace equipment, or nuclear control equipment). Also, when using this product for the equipment concerned with the control and safety of the transportation means, the traffic signal equipment, or various Types of safety equipment, please do it after applying appropriate measures to the product.
6. Despite our utmost efforts to improve the quality and reliability of the product, faults will occur with a certain small probability, which is inevitable to a semi-conductor product. Therefore, you are encouraged to have sufficiently redundant or error preventive design applied to the use of the product so as not to have our product cause any social or public damage.
7. Please note that this product is not designed to be radiation-proof.
8. Customers are asked, if required, to judge by themselves if this product falls under the category of strategic goods under the Foreign Exchange and Foreign Trade Control Law.

THine Electronics, Inc.

sales@thine.co.jp