



Chipsmall Limited consists of a professional team with an average of over 10 year of expertise in the distribution of electronic components. Based in Hongkong, we have already established firm and mutual-benefit business relationships with customers from,Europe,America and south Asia,supplying obsolete and hard-to-find components to meet their specific needs.

With the principle of "Quality Parts,Customers Priority,Honest Operation,and Considerate Service",our business mainly focus on the distribution of electronic components. Line cards we deal with include Microchip,ALPS,ROHM,Xilinx,Pulse,ON,Everlight and Freescale. Main products comprise IC,Modules,Potentiometer,IC Socket,Relay,Connector.Our parts cover such applications as commercial,industrial, and automotives areas.

We are looking forward to setting up business relationship with you and hope to provide you with the best service and solution. Let us make a better world for our industry!



Contact us

Tel: +86-755-8981 8866 Fax: +86-755-8427 6832

Email & Skype: info@chipsmall.com Web: www.chipsmall.com

Address: A1208, Overseas Decoration Building, #122 Zhenhua RD., Futian, Shenzhen, China



THCV217 / THCV218 Evaluation Kit



V-by-One[®] HS Dual Link Evaluation Board
 Parts Number: THEVA217-V2, THEVA218-V2

1. General Description

THEVA217-V2 and THEVA218-V2 are designed to support video data transmission between the host and Display. One high speed lane can carry up to 32bit data and 3 bits of synchronizing signals at a pixel clock frequency from 20MHz to 85MHz.

Table 1 Link and Clock Frequency

Chip	Link	Clock Freq.
THCV217	Si/So, Di/Do	20MHz to 85MHz
	Si / Do	40MHz to 170MHz
THCV218	Si/So, Di/Do	20MHz to 85MHz
	Di / So	40MHz to 170MHz

2. Features

- Color width selectable : 24/32 bit
- Single-In /Single-Out, Single-In /Dual-Out and Dual-In / Dual-Out selectable for THCV217
- Single-In /Single-Out, Dual-In /Single-Out and Dual-In / Dual-Out selectable for THCV218
- Wide frequency range
- PLL requires no external components
- V-by-One[®] HS standard version 1.4 compliant

3. Overview

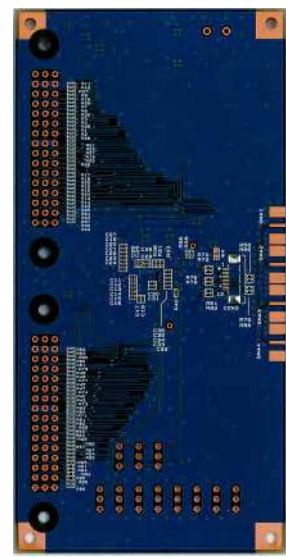
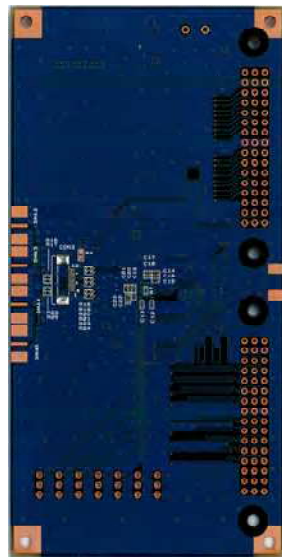
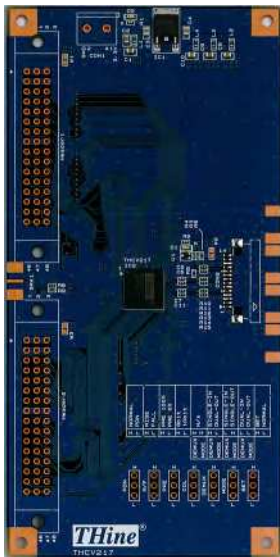

(a) THEVA217-V2 (Top Side)

(b) THEVA218-V2 (Top Side)

Figure 1 THEVA217-V2 and THEVA218-V2 Top Side View

4. Power Supply Setup

This chapter shows power supply condition.

Caution: Please check if there is no power-GND short on below red trace before supplying any power.

3.3V Power Supply to Each Board

Each evaluation board requires 3.3V power supply. Please use “CON1” connector typically.

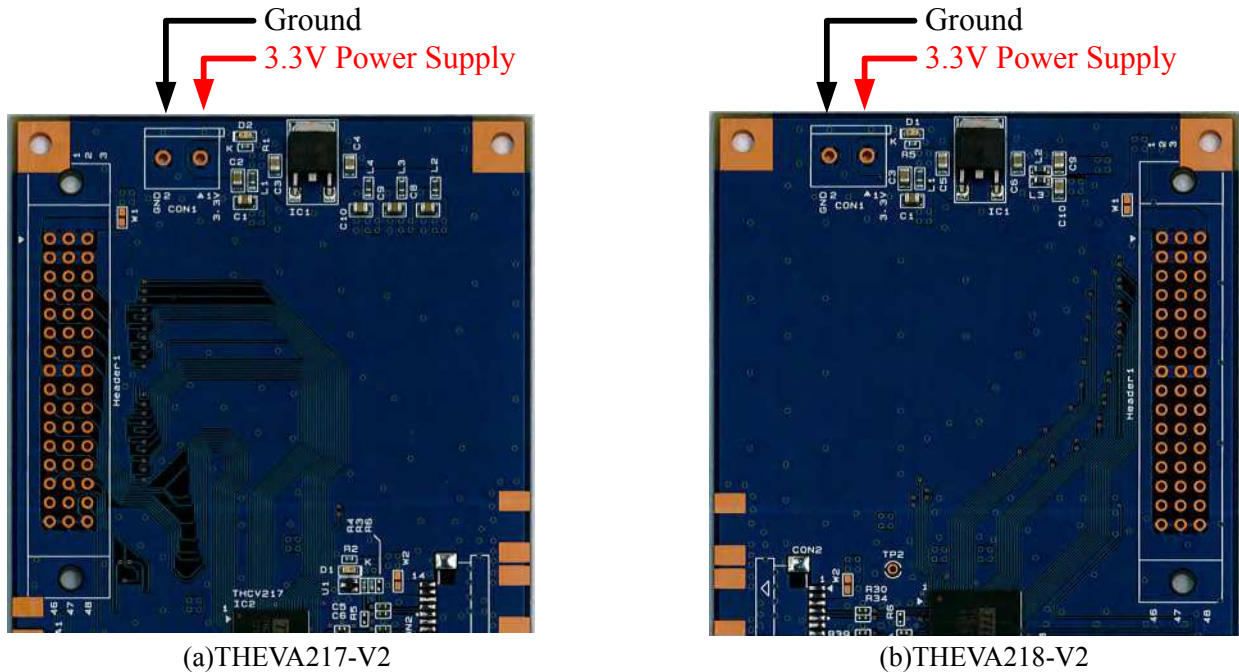

Figure 2 Power Supply for Evaluation Board

Power Supply from / to Connector

3.3V power supply can be connected to Header1 and CON2 by using W1, W2 and W4 solder jumper.

THEVA217-V2

- W1: Connect the 3.3V power supply with pin#1, 2 and 3 of Header1.
- W2: Connect the 3.3V power supply with pin#13 and 14 of CON2.
- W4: Connect the 3.3V power supply with pin#11 and 12 of CON3.

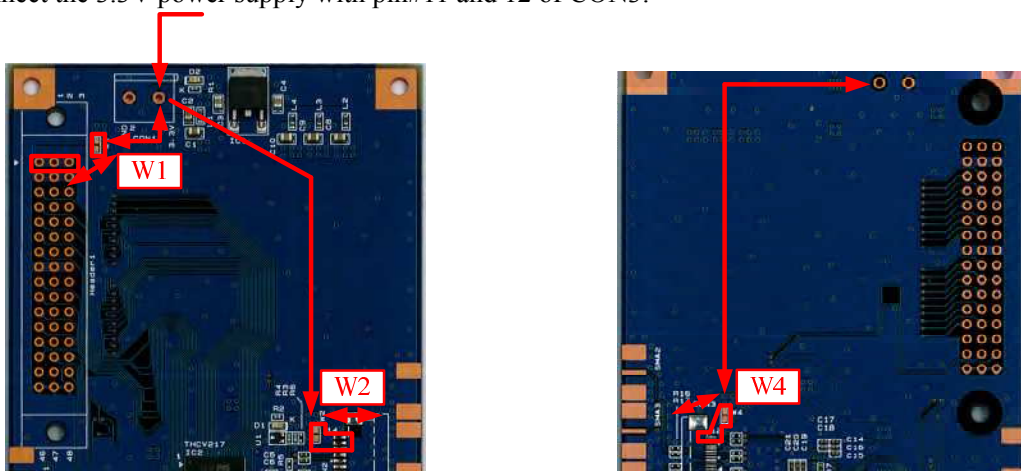

(a)THEVA217-V2 (Top Side)

(b) THEVA217-V2 (Bottom Side)

Figure 3 THEVA217-V2 Power Supply from / to Each Connector

THEVA218-V2

W1: Connect the 3.3V power supply with pin#1, 2 and 3 of Header1.

W2: Connect the 3.3V power supply with pin#1 and 2 of CON2.

W4: Connect the 3.3V power supply with pin#1 and 2 of CON3.

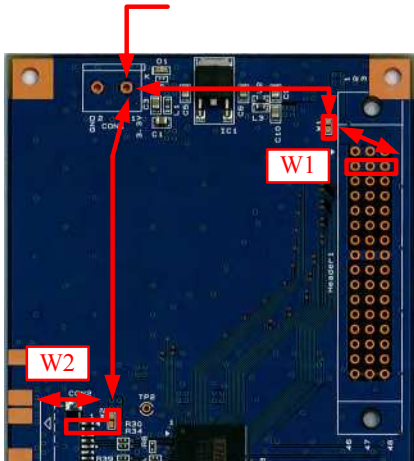

(a)THEVA218-V2 (Top Side)

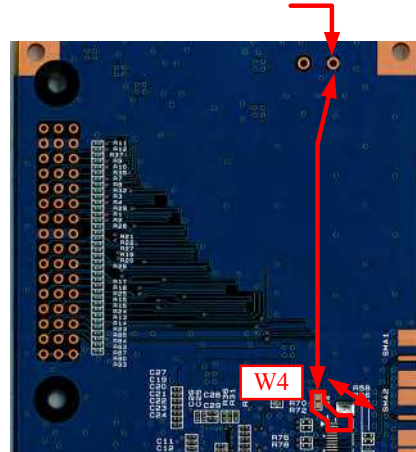

(b)THEVA218-V2 (Bottom Side)

Figure 4 THEVA218-V2 Power Supply from / to Each Connector

5. V-by-One[®] HS Input / Output Connector Select

V-by-One[®] HS input / output connector can be selected by using 0ohm resistors.

(1) 1mm Pitch Connector (Default Setting)

Please mount / unmount following 0ohm resistors to use 1mm pitch connector.

Table 2

	Mount	Unmount
THEVA217-V2	R10, R11, R12, R13, R14, R15	R18, R19, R20, R21, R23, R24
THEVA218-V2	R30, R34, R39, R41, R44, R46	R70, R72, R76, R78, R81, R82

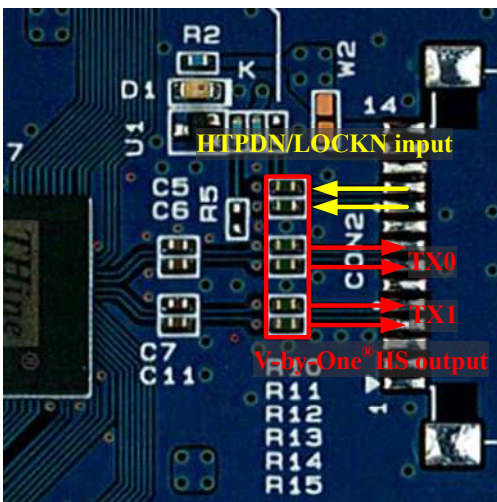

(a)THEVA217-V2 (Top Side)

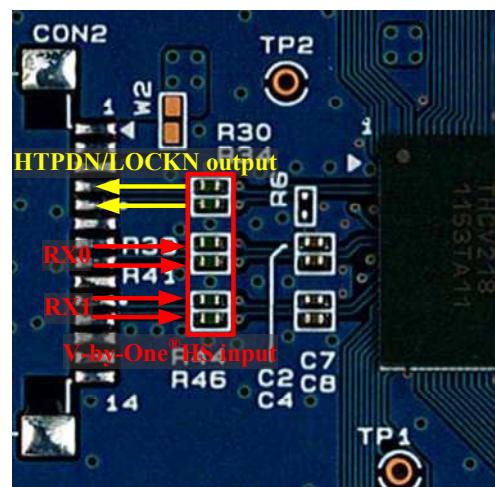

(b)THEVA218-V2 (Top Side)

Figure 5 Resistor Mounting for 1mm Pitch Connector

(2) 0.5mm Pitch Connector

Please mount / unmount following 0ohm resistors to use 0.5mm pitch connector.

Table 3

	Mount	Unmount
THEVA217-V2	R18, R19, R20, R21, R23, R24	R10, R11, R12, R13, R14, R15
THEVA218-V2	R70, R72, R76, R78, R81, R82	R30, R34, R39, R41, R44, R46

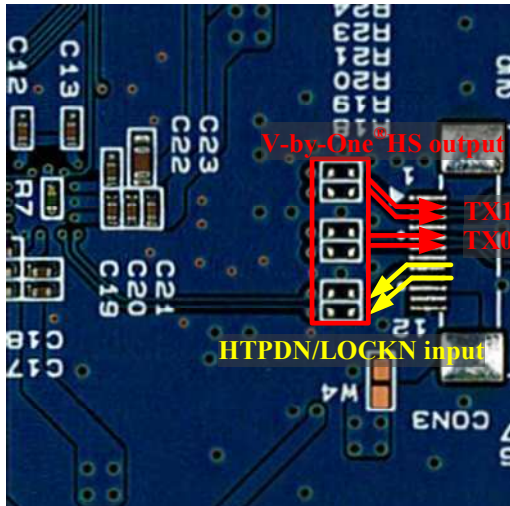

(a)THEVA217-V2 (Bottom Side)

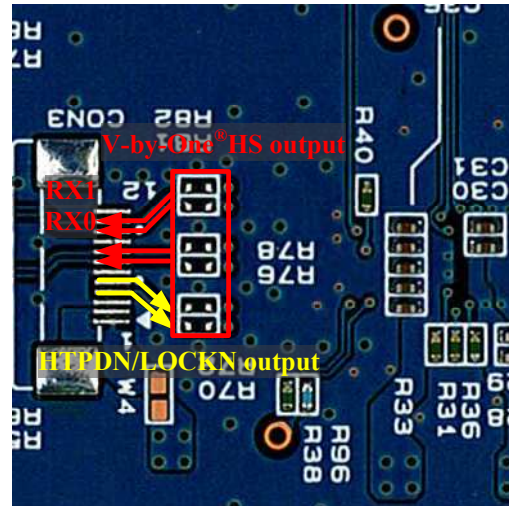

(b)THEVA218-V2 (Bottom Side)

Figure 6 Resistor Mounting for 0.5mm Pitch Connector

(3) SMA Connector

Please mount / unmount following 0ohm resistors to use SMA connector.

*HTPDN and LOCKN signals don't have SMA connector input / output connection.

Table 4

	Mount	Unmount
THEVA217-V2	R16, R17, R22, R25 R18, R19, R20, R21, R23, R24	R10, R11, R12, R13, R14, R15
THEVA218-V2	R58, R66, R75, R86 R70, R72, R76, R78, R81, R82	R30, R34, R39, R41, R44, R46

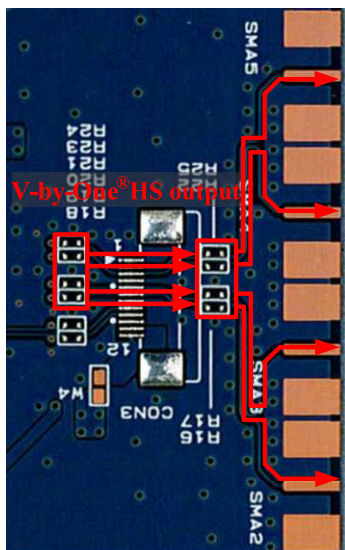

(a)THEVA217-V2 (Bottom Side)

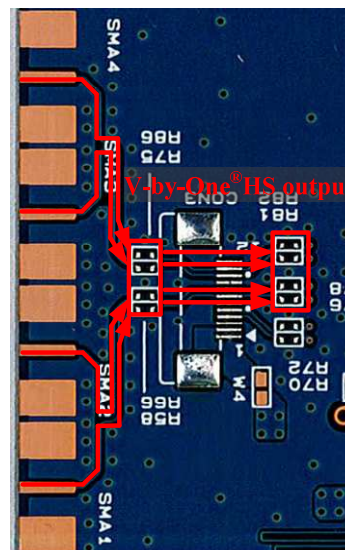

(b)THEVA218-V2 (Bottom Side)

Figure 7 Resistor Mounting for SMA Connector

6. Function Setting

Setting pin of each board is shown in yellow area of figure9. Pin#2 of each 3HEADER is connected to IC's setting pin.

Each setting pin's high or low setting can set by connecting pin#2 of 3HEADER and high level or low level.

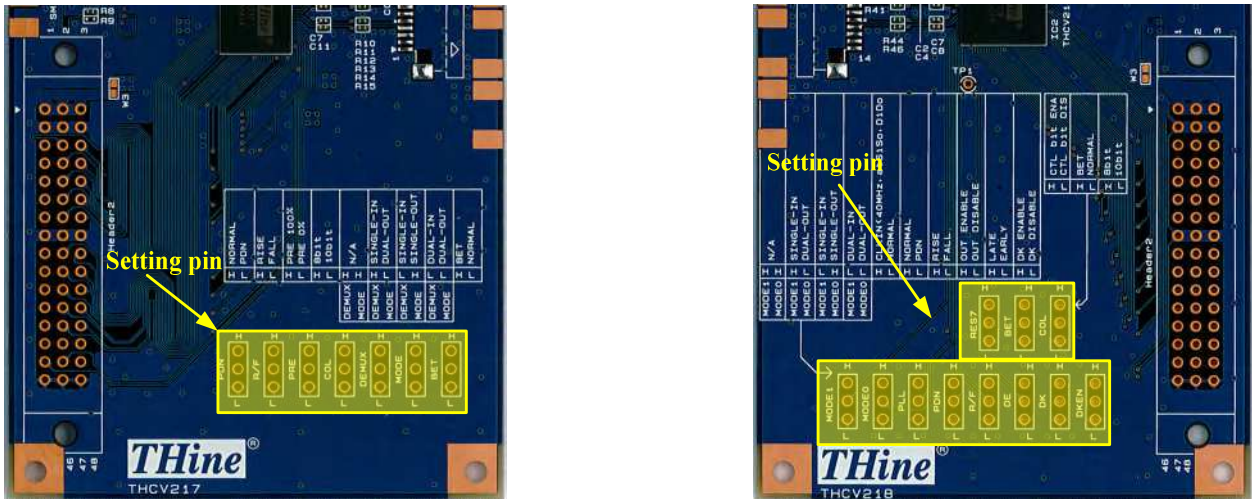
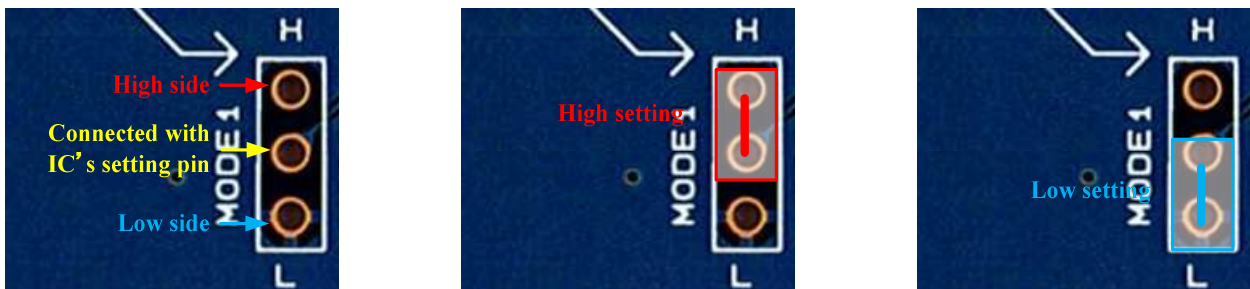

Figure 8 Position of Function Setting Pin



(a) 3HEADER description

(b) High level setting

(c) Low level setting

Figure 9 High / Low Setting Description

7. Clock Input from SMA Connector

THEVA217-V2 can also choose the TTL clock input from SMA connector by using 0ohm resistor.

If you want to use SMA connector for clock input, please change the 0ohm resistor mount from R8 to R9.

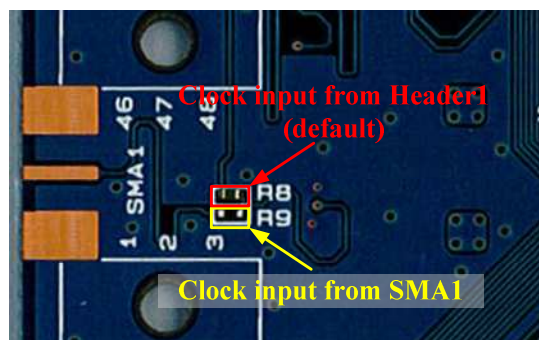

Figure 10 TTL Clock Input Connector Select

8. Status Indicate LED

The following table shows indicating status of each LED.

Table 5

	THEVA217-V2	THEVA218-V2
D1	LOCKN Status Indicator	3.3V Power Supply Indicator
D2	3.3V Power Supply Indicator	

9. LOCKN Sharing and HTPDN Omission

LOCKN Sharing

LOCKN connection can be shared with V-by-One®HS trace. When you share the LOCKN signal, Please mount 1k ohm resistors to share the LOCKN signal, and unmount the 0ohm resistors shown in Figure 11.

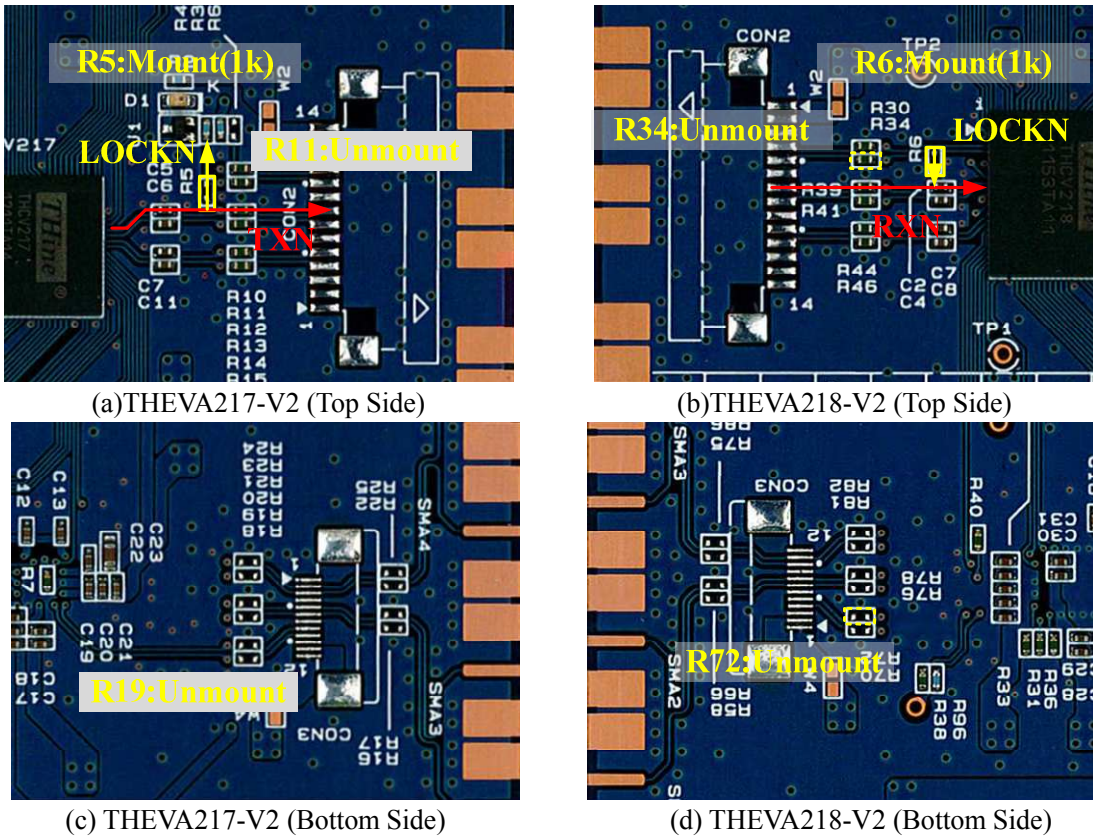
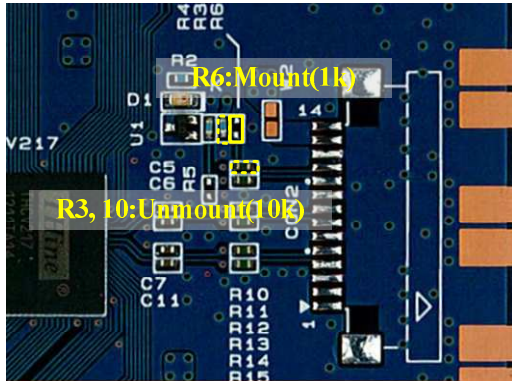

Figure 11 LOCKN Sharing

HTPDN Signal Omission

HTPDN signal can be omitted by using 1k ohm resistor. When you omit the HTPDN signal, Please mount 1k ohm resistors to pull down the HTPDN signal at transmitter side, and unmount the 0ohm resistors shown in Figure 12. When the HTPDN omission using, HTPDN output from receiver side is open connection.



(a)THEVA217-V2 (Top Side)

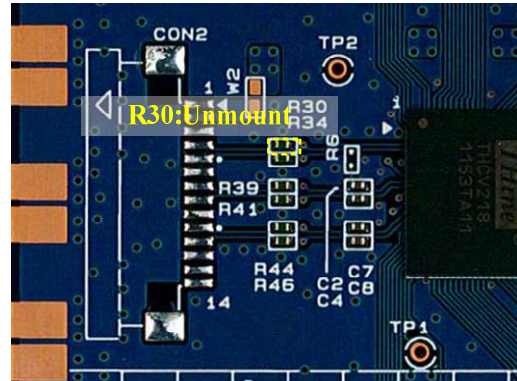

(b)THEVA218-V2 (Top Side)

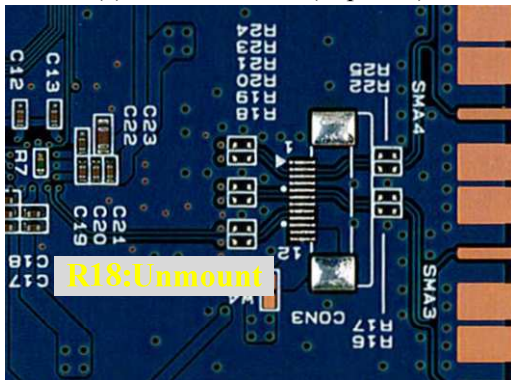

(c)THEVA217-V2 (Bottom Side)

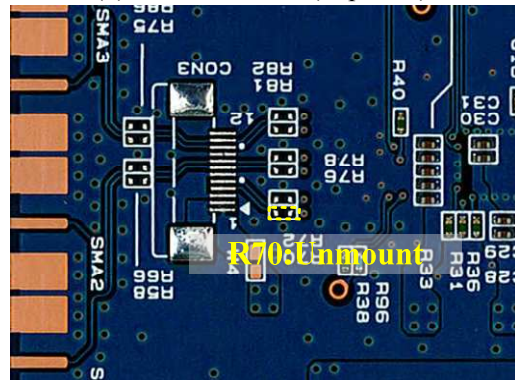

(d)THEVA218-V2 (Bottom Side)

Figure 12 HTPDN Signal Omission

10. Function

This chapter shows function setting of THEVA217-V2 and THEVA218-V2.

Table 6 THEVA217-V2 Function Setting Description

Silk	Symbol	Function
PDN	PDN	Power down input. H: Normal Operation L: Power Down
R/F	R/F	Input clock triggering edge select input for latching input data H : Rising Edge L : Falling Edge
PRE	PRE	Pre emphasis level select input H: 100% L: 0%
COL	COL	Color depth select input H : 8bit Mode L : 10bit Mode
DEMUX, MODE	DEMUX, MODE	Operation mode Select input DEMUX, MODE=HH : Reserved (Forbidden) HL : Single-In / Dual-Out LH : Single-In / Single-Out LL : Dual-In / Dual-Out
BET	BET	Field BET Enable H : Enable L : Normal Operation

Table 7 THEVA218-V2 Function Setting Description

Silk	Symbol	Function
MODE1, MODE0	MODE1, MODE0	Operation mode Select input HH : Reserved (Forbidden) HL : Single-In / Single-Out LH : Dual-In / Single-Out LL : Dual-In / Dual-Out
PLL	PLL	PLL Bandwidth select H: CLKIN<40MHz, when SiSo, DiDo L: Normal Operation
PDN	PDN	Power down input. H: Normal Operation L: Power Down Mode
R/F	R/F	Input clock triggering edge select input for latching input data H : Rising Edge L : Falling Edge
OE	OE	Output enable input H : All CMOS Outputs Enabled L : All CMOS Outputs Disabled, except for LOCKN, HTPDN

Silk	Symbol	Function
DK	DK	Output clock delay timing select input. Enabled by DKEN H : Late L : Early
DKEN	DKEN	DK enable H: DK Enabled L: DK Disabled (Default)
RES7	Reserved7	CTL bit transmission on DE=low blanking period enable H : CTL Bit Enabled (CTL are transmitted except the 1 st and the last pixel of DE=low) L : CTL Bit Disabled (CTL are low fixed during DE=low) When BET=high, Reserved7 must be low
BET	BET	Field BET Enable H : Enable L : Normal Operation
COL	COL	Color depth select input H : 8bit Mode L : 10bit Mode

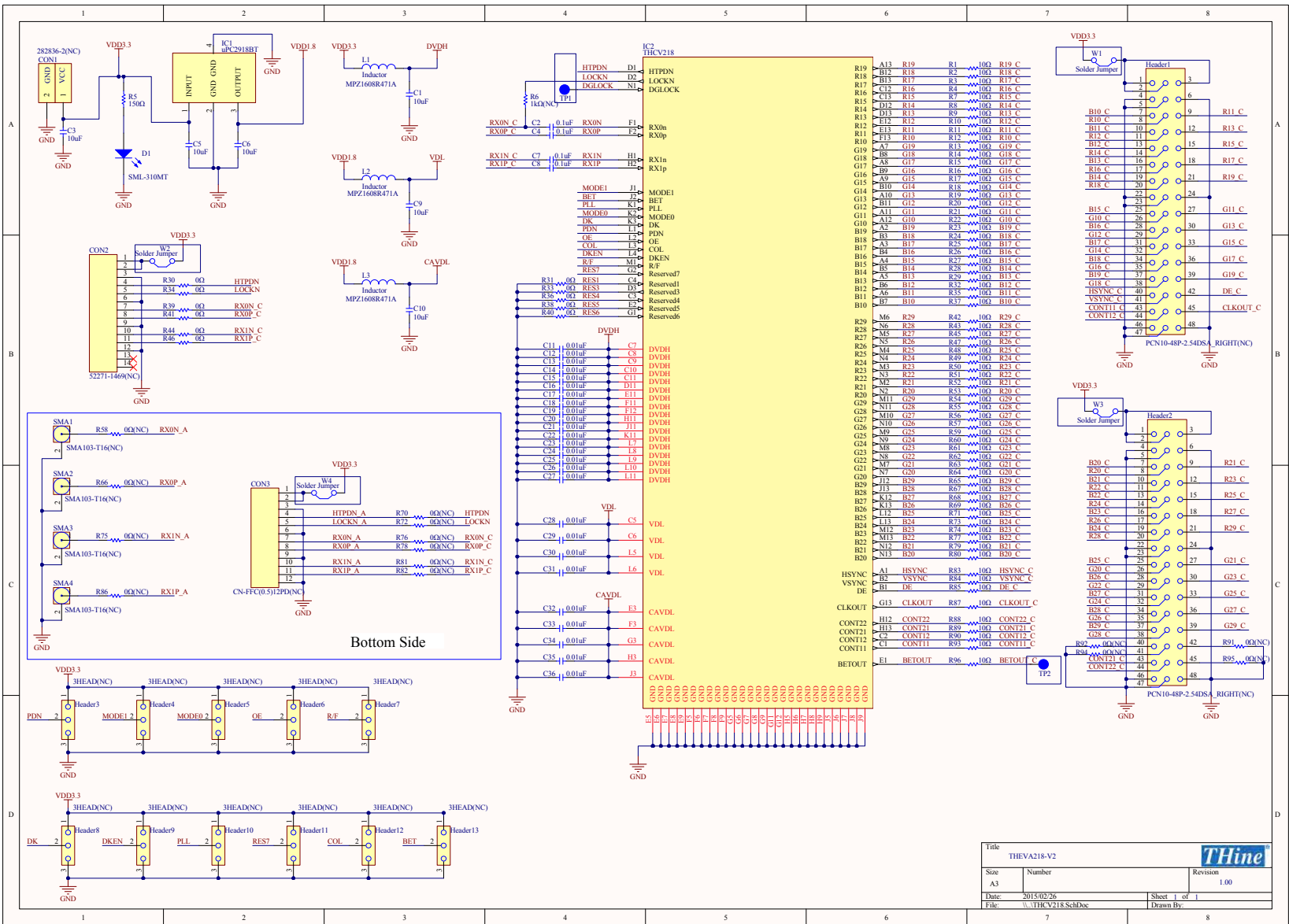

Figure 14 THEVA218-V2 schematic

Title		THEVA218-V2		THine	
Size	A3	Number		Revision	1.00
Date	2015/02/26	Sheet	1 of 1	Drawn By	
File	\\THCV218.SchDoc				

12. Bills of Materials

Table 8 THEVA217-V2 BOM

TYPE	Value / Part No.	Package	SPEC	Reference No.	Qty	Note
Capacitor	10uF	2012	16V	C1, C2, C3, C4, C8, C9, C10	7	
Capacitor	4.7uF	1608	16V	C23	1	
Capacitor	0.1uF	1005	16V	C5, C6, C7, C11	4	
Capacitor	0.01uF	1005	16V	C12, C13, C14, C15, C16, C17, C18, C19, C20, C21, C22	11	
Connector	SMA103-T16(NC)	1.6mm	PCB End Jack	SMA1, SMA2, SMA3, SMA4, SMA5	5	
Connector	PCN10-48P-2.54DSA LEFT(NC)	2.54mm pitch	48pin	Header1, Header2	2	
Connector	CN-FFC(0.5)12PD(NC)	0.5mm pitch	12pin	CON3	1	
Connector	52271-1469(NC)	1mm pitch	14pin	CON2	1	
Connector	282836-2(NC)	5mm pitch	2pin	CON1	1	
Header	3HEAD(NC)	2.54mm pitch	---	Header3, Header4, Header5, Header6, Header7, Header8, Header9	7	
IC	SSM3K16FS	SSM	RON15Ω	U1	1	
IC	THCV217	TFBGA105	THCV217	IC2	1	
IC	uPC2918BT	SC-63	1A	IC1	1	
Inductor	MPZ1608R471A	1608	1.2A	L1, L2, L3, L4	4	
LED0	SML-310MT	1608	GREEN	D1, D2	2	
Resistor	150Ω	1005	0.1W	R1, R2	2	
Resistor	10kΩ	1005	0.1W	R3, R4	2	
Resistor	1kΩ(NC)	1005	0.1W	R5, R6	2	
Resistor	0Ω(NC)	1005	1A	R9, R16, R17, R18, R19, R20, R21, R22, R23, R24, R25	11	
Resistor	0Ω	1005	1A	R7, R8, R10, R11, R12, R13, R14, R15	8	

Table 9 THEVA218-V2 BOM

TYPE	Value / Part No.	Package	SPEC	Reference No.	Qty	Note
Capacitor	10uF	2012	16V	C1, C3, C5, C6, C9, C10	6	
Capacitor	0.1uF	1005	16V	C2, C4, C7, C8	4	
Capacitor	0.01uF	1005	16V	C11, C12, C13, C14, C15, C16, C17, C18, C19, C20, C21, C22, C23, C24, C25, C26, C27, C28, C29, C30, C31, C32, C33, C34, C35, C36	26	
Connector	282836-2(NC)	5mm pitch	2pin	CON1	1	
Connector	52271-1469(NC)	1mm pitch	14pin	CON2	1	
Connector	CN-FFC(0.5)12PD(NC)	0.5mm pitch	12pin	CON3	1	
Connector	PCN10-48P-2.54DSA RIGHT(NC)	2.54mm pitch	48pin	Header1, Header2	2	
Connector	SMA103-T16(NC)	1.6mm	PCB End Jack	SMA1, SMA2, SMA3, SMA4	4	
Header	3HEAD(NC)	2.54mm pitch	---	Header3, Header4, Header5, Header6, Header7, Header8, Header9, Header10, Header11, Header12, Header13	11	
IC	THCV218	TFBGA145	THCV218	IC2	1	
IC	uPC2918BT	SC-63	1A	IC1	1	
Inductor	MPZ1608R471A	1608	1.2A	L1, L2, L3	3	
LED0	SML-310MT	1608	GREEN	D1	1	
Resistor	10Ω	Resistor	0.1W	R1, R2, R3, R4, R7, R8, R9, R10, R11, R12, R13, R14, R15, R16, R17, R18, R19, R20, R21, R22, R23, R24, R25, R26, R27, R28, R29, R32, R35, R37, R42, R43, R45, R47, R48, R49, R50, R51, R52, R53, R54, R55, R56, R57, R59, R60, R61, R62, R63, R64, R65, R67, R68, R69, R71, R73, R74, R77, R79, R80, R83, R84, R85, R87, R88, R89, R90, R93, R96	69	
Resistor	150Ω	1005	0.1W	R5	1	
Resistor	1kΩ(NC)	1005	0.1W	R6	1	
Resistor	0Ω	1005	1A	R30, R31, R33, R34, R36, R38, R39, R40, R41, R44, R46	11	
Resistor	0Ω(NC)	1005	1A	R58, R66, R70, R72, R75, R76, R78, R81, R82, R86, R91, R92, R94, R95	14	

13. Set Items

Table 10

TYPE	Part No.
DC Connector	282836-2
FFC Connector for V-by-One [®] HS Link	52271-1469
FFC 14pin 1mm Pitch for V-by-One [®] HS Link	98267-0299
Pin Header	---

It's possible to mount these parts on this board and use.

14. Notices and Requests

Please kindly read, understand and accept this “Notices and Requests” before using this product.

For the Material:

1. The product specifications described in this material are subject to change without prior notice.
2. The circuit diagrams described in this material are examples of the application which may not always apply to design of respective customers. THine Electronics, Inc. (“THine”) is not responsible for possible errors and omissions in this material. Please note if the errors or omissions should be found in this material, THine may not be able to correct them immediately.
3. This material contains THine’s copyright, know-how or other proprietary. Copying or disclosing of the contents of this material to any third party without THine’s prior permission is strictly prohibited.

For the Product:

1. This product is solely designed for evaluation purpose, and other purposes including mass production and distribution are not intended.
2. This product has been solely manufactured for electric design engineers but not for end-users.
3. This product is not radiation-tolerant product.
4. This product is presumed to be used for general electric device, not for applications which require extremely high-reliability/safety (including medical device concerned with critical care, aerospace device, or nuclear power control device). Also, when using this product for any device concerned with control and/or safety of transportation mean, traffic signal device, or other various types of safety device, such use must be after applying appropriate measures to the product.
5. This product has been designed with the utmost care to accomplish the purpose of evaluation of IC products manufactured by THine Electronics, Inc., however, THine MAKES NO WARRANTIES OR REPRESENTATIONS WITH REGARD TO ANY PERFORMANCE OR FUNCTION OF THIS PRODUCT IN ANY CIRCUMSTANCE.
6. This product has been manufactured with the utmost care in quality control and product reliability, however, there may be faults or defects with a low but fixed probability, as inevitable phenomenon concerned with semiconductor manufacturing processes. Therefore, Customers are encouraged to have sufficiently redundant or error-preventive design applied to the use of the product so as not to have THine’s product cause any social or public damage. Replacement of the product is only available in case of obvious defects of mount devices at the point of unpacking the product. Neither replacement nor failure analysis of the product is available in any other case of defects with the product and/or the product’s components.
7. Customers are asked, if required, to judge by themselves on whether this product falls under the category of strategic goods under the Foreign Exchange and Foreign Trade Control Law.
8. Please Note that if infringement of any third party’s industrial ownership should occur by using this product, THine will be exempted from any responsibility unless it directly relates to the production process or functions of the product.
9. Developing, designing and manufacturing of Customers’ own products, equipments or system by using of this product is strictly prohibited in any way.

THine Electronics, Inc.

sales@thine.co.jp