



Chipsmall Limited consists of a professional team with an average of over 10 year of expertise in the distribution of electronic components. Based in Hongkong, we have already established firm and mutual-benefit business relationships with customers from,Europe,America and south Asia,supplying obsolete and hard-to-find components to meet their specific needs.

With the principle of "Quality Parts,Customers Priority,Honest Operation,and Considerate Service",our business mainly focus on the distribution of electronic components. Line cards we deal with include Microchip,ALPS,ROHM,Xilinx,Pulse,ON,Everlight and Freescale. Main products comprise IC,Modules,Potentiometer,IC Socket,Relay,Connector.Our parts cover such applications as commercial,industrial, and automotives areas.

We are looking forward to setting up business relationship with you and hope to provide you with the best service and solution. Let us make a better world for our industry!



Contact us

Tel: +86-755-8981 8866 Fax: +86-755-8427 6832

Email & Skype: info@chipsmall.com Web: www.chipsmall.com

Address: A1208, Overseas Decoration Building, #122 Zhenhua RD., Futian, Shenzhen, China



THCV231 and THCV236

SerDes transmitter and receiver with bi-directional transceiver

General Description

The THCV231 and THCV236 are designed to support video data transmission between the host and display.

THCV231

One high-speed lane can carry up to 14bits data at a pixel clock frequency from 12MHz to 160MHz.

THCV236

One high-speed lane can carry up to 32bit data and 3bits of synchronizing signals at a pixel clock frequency from 6MHz to 160MHz by converting RGB444 to YCbCr422.

The chipset, which has one high-speed data lane, can transmit video data up to 1080p/60Hz.

The maximum serial data rate is 4.00Gbps/lane.

Features

- Data width selectable
- Wide frequency range
- AC coupling for high-speed lanes
- CDR requires no external frequency reference
- Wide range supply voltage from 1.7V to 3.6V
- Additional spread spectrum on data stream
- 2-wire serial interface bridge function(400kbps)
- Remote side GPIO control and monitoring
- THCV231
 - QFN32 (5mm x 5mm) with exposed pad ground
- THCV236
 - QFN64 (9mm x 9mm) with exposed pad ground
- EU RoHS compliant

Block Diagram

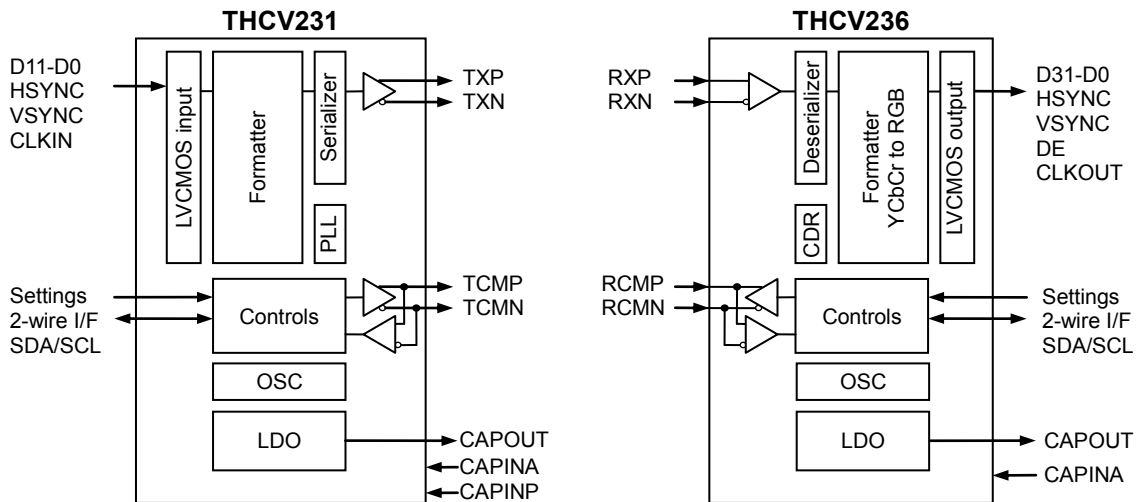

Contents Page

| | |
|---|----|
| General Description | 1 |
| Features | 1 |
| Block Diagram | 1 |
| Pin Configuration | 3 |
| Pin Description | 4 |
| Functional Overview | 9 |
| Functional Description | 9 |
| Internal Reference Output/Input Function (CAPOUT, CAPINA, CAPINP) | 9 |
| Power Down (PDN1, PDN0, PDN) | 10 |
| Pre-emphasis and Drive Select Function (THCV231 only) | 10 |
| Permanent Clock Output (THCV236 only) | 10 |
| Spread Spectrum Clock Generator (SSCG) | 11 |
| Hot-Plug Function | 13 |
| Lock Detect Function | 13 |
| Field BET Operation | 14 |
| Data Width and Frequency Range Select Function | 16 |
| Data Mapping | 16 |
| 2-wire serial I/F Mode | 17 |
| 2-wire serial I/F Device ID setting | 17 |
| 2-wire serial I/F Clock Stretching | 17 |
| Read/Write access to Sub-Link Master Register | 19 |
| Read/Write access to Sub-Link Slave Register | 20 |
| Read/Write access to remote side 2-wire serial slave devices connected to Sub-Link Slave Device | 22 |
| GPIO | 26 |
| Interruption | 28 |
| Register Map | 29 |
| Absolute Maximum Ratings | 38 |
| Recommended Operating Conditions | 38 |
| Electrical Specification | 38 |
| AC Timing Diagrams and Test Circuits | 44 |
| PCB Layout Guideline regarding VDD and AVDD for THCV236 | 53 |
| Package | 54 |
| Notices and Requests | 56 |

Pin Configuration

THCV231 (QFN 32pin)

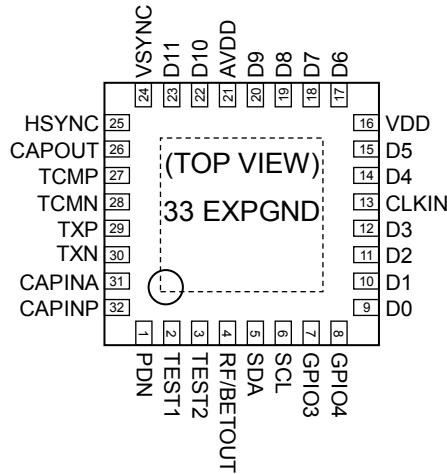

THCV236 (QFN 64pin)

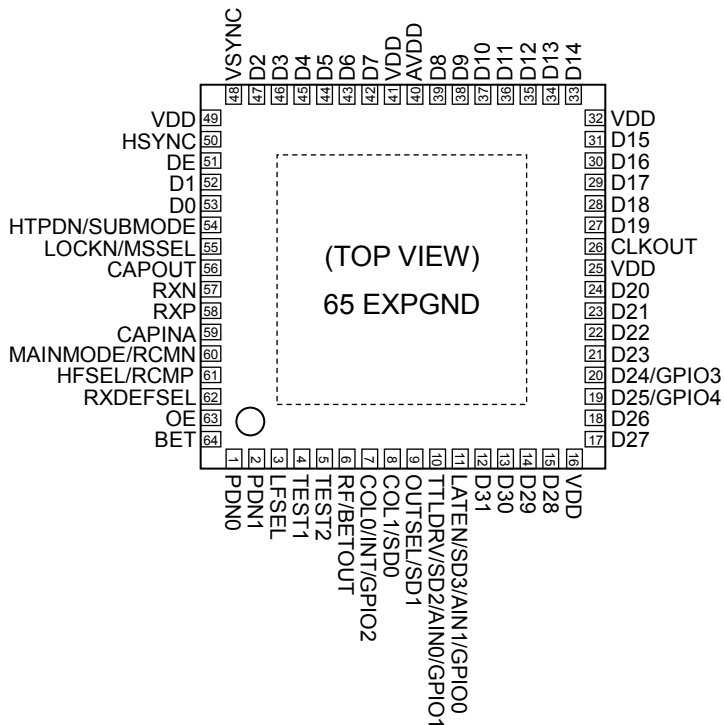

Pin Description

Pin Description for THC231

| Pin Name | Pin No. | Type | Description |
|-----------|------------------------|------|---|
| TXP | 29 | CO | High-Speed CML Signal Output (Main-Link) |
| TXN | 30 | CO | High-Speed CML Signal Output (Main-Link) |
| TCMP | 27 | CB | CML Signal Bidirectional Input/Output (Sub-Link) |
| TCMN | 28 | CB | CML Signal Bidirectional Input/Output (Sub-Link) |
| GPIO4 | 8 | B | <p><u>GPIO4</u> : General Purpose Input/Output. When GPIO4 is used as Open-Drain Output, it must be connected with a pull-up resistor to VDD. When GPIO4 is used as push pull output, no external component is required. <u>LATEN</u> : Latch select input under Field BET (Sub-Link) 0 : Forbidden 1 : Latched result</p> |
| GPIO3 | 7 | B | <p><u>GPIO3</u> : General Purpose Input/Output. When GPIO3 is used as Open-Drain Output, it must be connected with a pull-up resistor to VDD. When GPIO3 is used as push pull output, no external component is required.</p> |
| SCL | 6 | B | SCL input/output for 2-wire serial I/F. |
| SDA | 5 | B | SDA input/output for 2-wire serial I/F. |
| CLKIN | 13 | I | Clock Input |
| D11-D0 | 23,22,20-17,15,14,12-9 | I | Pixel Data Input |
| HSYNC | 25 | I | HSYNC Input |
| VSYNC | 24 | I | VSYNC Input |
| RF/BETOUT | 4 | B | <p><u>RF</u> : Input Clock Triggering edge select. See Figure 15. 0 : Falling Edge 1 : Rising Edge <u>BETOUT</u> : Field BET Result Output when Field BET mode.</p> |
| PDN | 1 | IL | <p>Power Down 0 : Power Down 1 : Normal Operation</p> |
| TEST2 | 3 | I | Test pin. Must be tied to Ground for normal operation. |
| TEST1 | 2 | IL | Test pin. Must be tied to Ground for normal operation. |
| CAPOUT | 26 | PWR | Decoupling Capacitor Pin, 1.2V output. |
| CAPINA | 31 | PWR | Reference Input for Analog Circuit. Must be tied to CAPOUT. |
| CAPINP | 32 | PWR | Reference Input for Analog Circuit. Must be tied to CAPOUT. |
| VDD | 16 | PWR | 1.7-3.6V Digital Power Supply Pin for LVCMOS I/O |
| AVDD | 21 | PWR | 1.7-3.6V Analog Power Supply Pin for LDO |
| EXPGND | 33 | GND | Exposed Pad Ground. Must be tied to the PCB ground plane through an array of vias. |

CO : CML Output buffer , CB : CML Bi-directional buffer

I : LVCMOS Input buffer , IL : Low Speed LVCMOS Input buffer , B : LVCMOS Bi-directional buffer

PWR : Power supply , GND : Ground

Pin Description for THC236

| Pin Name | Pin No. | Type | Description |
|----------------------|---------|------|---|
| RXP | 58 | CI | High-Speed CML Signal Input(Main-Link) |
| RXN | 57 | CI | High-Speed CML Signal Input(Main-Link) |
| HFSEL/RCMP | 61 | CB/I | <u>HFSEL</u> : High Frequency Mode select when PDN1=0. 0 : High Frequency Mode Disable 1 : High Frequency Mode Enable <u>RCMP</u> : CML Signal Bi-directional Input/Output(Sub-Link) when PDN1=1. |
| MAINMODE/RCMN | 60 | CB/I | <u>MAINMODE</u> : Setting V-by-One [®] HS Mode or Sync Free Mode when PDN1=0 0 : V-by-One [®] HS Mode 1 : Sync Free Mode <u>RCMN</u> : CML Signal Bi-directional Input/Output(Sub-Link) when PDN1=1. |
| HTPDN/SUBMODE | 54 | BO | <u>HTPDN</u> : Hot Plug Detect Output when PDN1=0. Must be connected to Tx HTPDN with 10kΩ pull-up resistor. <u>SUBMODE</u> : Sub-Link Mode Select when PDN1=1. 0 : 2-wire serial I/F Mode (default No Clock Stretching mode) 1 : Low Speed Data Bridge Mode Forbid setting 1 when connecting with THC231. |
| LOCKN/MSEL | 55 | BO | <u>LOCKN</u> : Lock Detect Output when PDN1=0. Must be connected to Tx LOCKN with 10kΩ pull-up resistor. <u>MSEL</u> : Sub-Link Master/Slave Select when PDN1=1. 0 : Sub-Link Master side(inside 2-wire serial I/F is slave) 1 : Sub-Link Slave side(inside 2-wire serial I/F is master) Sub-Link Master is connected to HOST MPU. Forbid setting 1 when connecting with THC231. |
| LATEN/SD3/AIN1/GPIO0 | 11 | B | <u>LATEN</u> : Latch select input under Field BET(Main-Link or Sub-Link). 0 : NOT Latched result 1 : Latched result <u>SD3</u> : Sub-Link Data Input/Output when PDN1=1 and SUBMODE=1. When Sub-Link is Master (MSEL=0), SD3 is output. When Sub-Link is Slave (MSEL=1), SD3 is input. <u>AIN1</u> : Device ID setting for 2-wire serial I/F when SUBMODE=0 and MSEL=0. See Table 18. <u>GPIO0</u> : General Purpose Input/Output when SUBMODE=0 and MSEL=1. When GPIO0 is used as Open-Drain Output, it must be connected with a pull-up resistor to VDD. When GPIO0 is used as push pull output or input, no external component is required. |

| | | | |
|---------------------------|-------------|---|---|
| TTLDRV/SD2/ AIN0/GPIO1 | 10 | B | <p><u>TTLDRV</u> : LVCMOS Output Drive Strength Select when PDN1=0. 0 : Weak Drive Strength 1 : Normal Drive Strength</p> <p><u>SD2</u> : Sub-Link Data Input/Output when PDN1=1 and SUBMODE=1. When Sub-Link is Master (MSSEL=0), SD2 is input. When Sub-Link is Slave (MSSEL=1), SD2 is output.</p> <p><u>AIN0</u> : Device ID setting for 2-wire serial I/F when SUBMODE=0 and MSSEL=0. See Table 18.</p> <p><u>GPIO1</u> : General Purpose Input/Output when SUBMODE=0 and MSSEL=1. When GPIO1 is used as Open-Drain Output, it must be connected with a pull-up resistor to VDD. When GPIO1 is used as push pull output or input, no external component is required.</p> |
| OUTSEL/SD1 | 9 | B | <p><u>OUTSEL</u> : Permanent Clock Output Enable when PDN1=0. 0 : Permanent Clock Output Disable 1 : Permanent Clock Output Enable</p> <p><u>SD1</u> : Sub-Link Data Input/Output when PDN1=1. When SUBMODE=0, SD1 is used as SCL input/output for 2-wire serial I/F, requires pull-up resistor to VDD. When SUBMODE=1 and MSSEL=0, SD1 is input. When SUBMODE=1 and MSSEL=1, SD1 is output.</p> |
| COL1/SD0 | 8 | B | <p><u>COL1</u> : Color Space Converter Enable when PDN1=0 and MAINMODE=0. 0 : Color Space Converter Disable 1 : Color Space Converter Enable</p> <p>Data Width Setting when PDN1=0 and MAINMODE=1. See Table 15.</p> <p><u>SD0</u> : Sub-Link Data Input/Output when PDN1=1. When SUBMODE=0, SD0 is used as SDA input/output for 2-wire serial I/F, requires pull-up resistor to VDD. When SUBMODE=1 and MSSEL=0, SD0 is input. When SUBMODE=1 and MSSEL=1, SD0 is output.</p> |
| COL0/INT/ GPIO2 | 7 | B | <p><u>COL0</u> : Data Width Setting when PDN1=0. See Table 15.</p> <p><u>INT</u> : Interrupt signal output for Sub-Link when SUBMODE=0 and MSSEL=0. It must be connected with a pull-up resistor to VDD. L : Interrupt occurred H : Steady state</p> <p><u>GPIO2</u> : General Purpose Input/Output when SUBMODE=0 and MSSEL=1. When GPIO2 is used as Open-Drain Output, it must be connected with a pull-up resistor to VDD. When GPIO2 is used as push pull output or input, no external component is required.</p> |
| CLKOUT | 26 | O | Clock Output |
| D31-D26 | 12-15,17,18 | O | Pixel Data Output |

| | | | |
|-----------|-------------------------------|-----|--|
| D25/GPIO4 | 19 | B | <u>D25</u> : Pixel Data Output <u>GPIO4</u> : General Purpose Input/Output when SUBMODE=0, MSSEL=1 and RXDEFSEL=0. When GPIO4 is used as Open-Drain Output, it must be connected with a pull-up resistor to VDD. When GPIO4 is used as push pull output or input, no external component is required. |
| D24/GPIO3 | 20 | B | <u>D24</u> : Pixel Data Output <u>GPIO3</u> : General Purpose Input/Output when SUBMODE=0, MSSEL=1 and RXDEFSEL=0. When GPIO3 is used as Open-Drain Output, it must be connected with a pull-up resistor to VDD. When GPIO3 is used as push pull output or input, no external component is required. |
| D23-D0 | 21-24,27-31,33-39,42-47,52,53 | O | Pixel Data Output |
| DE | 51 | O | DE Output |
| HSYNC | 50 | O | HSYNC Output |
| VSYNC | 48 | O | VSYNC Output |
| OE | 63 | IL | Output Enable 0 : LVC MOS Output Disable (Hi-Z) except for HTPDN, LOCKN when PDN1=0 and except for BETOUT when BET=1 1 : LVC MOS Output Enable |
| BET | 64 | IL | Field BET entry 0 : Normal Operation 1 : Field BET Operation |
| RF/BETOUT | 6 | B | <u>RF</u> : Output Clock Triggering edge select. See Figure 16. 0 : Falling Edge 1 : Rising Edge <u>BETOUT</u> : Field BET Result Output |
| RXDEFSEL | 62 | I | Internal Register Default Setting Select. See Table 35, Table 36 0 : for THCV231 1 : for THCV235 |
| LFSEL | 3 | I | Low Frequency mode select 0 : Low Frequency mode Disable 1 : Low Frequency mode Enable Forbid setting 1 when connecting with THCV231. |
| PDN1 | 2 | IL | Sub-Link Power Down 0 : Power Down. Main-Link setting by external pin 1 : Normal Operation. Main-Link Setting by 2-wire serial I/F |
| PDN0 | 1 | IL | Main-Link Power Down 0 : Power Down 1 : Normal Operation |
| TEST2 | 5 | I | Test pin. Must be tied to Ground for normal operation. |
| TEST1 | 4 | IL | Test pin. Must be tied to Ground for normal operation. |
| CAPOUT | 56 | PWR | Decoupling Capacitor Pin, 1.2V output. |
| CAPINA | 59 | PWR | Reference Input for Analog Circuit. Must be tied to CAPOUT. |
| VDD | 49,41,32,25,16 | PWR | 1.7-3.6V Digital Power Supply Pin for LVC MOS I/O |
| AVDD | 40 | PWR | 1.7-3.6V Analog Power Supply Pin for LDO |
| EXPGND | 65 | GND | Exposed Pad Ground. Must be tied to the PCB ground plane through an array of vias. |

CI : CML Input buffer , CB : CML Bi-directional buffer
 I : LVC MOS Input buffer , IL : Low Speed LVC MOS Input buffer , O: LVC MOS Output buffer
 B : LVC MOS Bi-directional buffer , BO : Open-Drain LVC MOS Bi-directional buffer
 PWR : Power supply , GND : Ground

Table 1. Pin Sharing Description (THCV231-THCV236 usage)

| Sub-Link State → | 2-wire serial I/F Mode |
|-------------------------|------------------------|
| Sub-Link Master/Slave → | Master |
| PDN1 | 1 |
| HTPDN/SUBMODE | 0 |
| LOCKN/MSEL | 0 |
| BET | 0 |
| RXDEFSEL | 0 |
| RF/BETOUT | RF |
| | BETOUT(*1) |
| COL0/INT/GPIO2 | INT |
| COL1/SD0 | SD0(SDA) |
| OUTSEL/SD1 | SD1(SCL) |
| TTLDRV/SD2/AIN0/GPIO1 | AIN0 |
| | AIN1 |
| LATEN/SD3/AIN1/GPIO0 | LATEN(*2) |
| D24/GPIO3 | GPIO3(*3) |
| D25/GPIO4 | GPIO4(*3) |
| HTPDN/SUBMODE | SUBMODE |
| LOCKN/MSEL | MSEL |
| MAINMODE/RCMN | RCMN |
| HFSEL/RCMP | RCMP |

*1 When Field BET mode (Main-Link or Sub-Link), it functions as BETOUT output.

*2 When Field BET mode (Main-Link or Sub-Link), it functions as LATEN input.

*3 Through GPIO input is default on register setting

Functional Overview

With High Speed CML SerDes, proprietary encoding scheme and CDR (Clock and Data Recovery) architecture, the THCV231 and THCV236 enable transmission of 14bit data through Main-Link by single differential pair cable with minimal external components. In addition, the THCV231 and THCV236 have Sub-Link which enables bi-directional transmission of 2-wire serial interface signals, GPIO signals and also HTPDN/LOCKN signals for Main-Link through the other 1-pair of CML-Line. It does not need any external frequency reference such as a crystal oscillator. The THCV231 - THCV236 system is able to watch peripheral devices and to control them via 2-wire serial interface or GPIOs. They also can report interrupt events caused by change of GPIO inputs and internal statuses.

Functional Description

Internal Reference Output/Input Function (CAPOUT, CAPINA, CAPINP)

An internal regulator produces the 1.2V (CAPOUT). This 1.2V linear regulator can't supply any other external loads. Bypass CAPOUT to GND with 10uF.

CAPINP (THCV231 only) supplies reference voltage for internal PLL, and CAPINA supplies reference voltage for any internal analog circuit. Bypass CAPINP/CAPINA to GND with 0.1uF to remove high frequency noise. CAPOUT, CAPINA and CAPINP must be tied together.

Power supply AVDD is supposed to be stabilized with de-coupling capacitor and series noise filter (for example, ferrite bead).

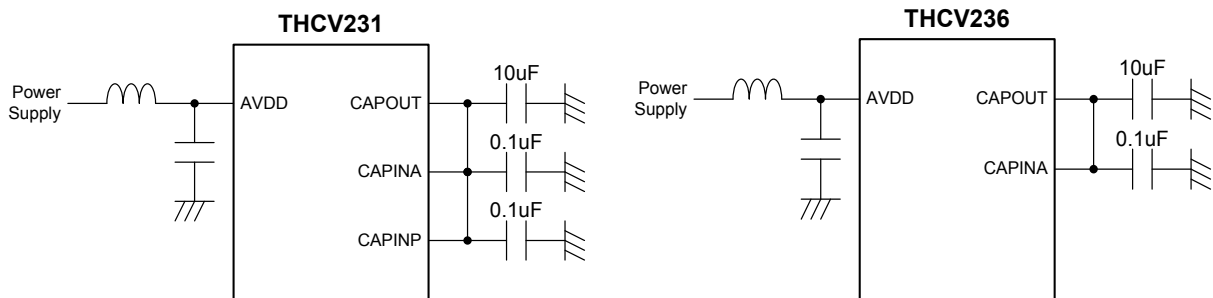

Figure 1. Connection of CAPOUT, CAPINA, CAPINP and Decoupling Capacitor

Power Down (PDN1, PDN0, PDN)

PDN1, PDN0 and PDN turn off internal circuitry of Main-Link and Sub-Link separately.

Table 2. Power Down Setting(THCV231)

| PDN | Operation |
|-----|--|
| 0 | Both Main-Link and Sub-Link power down |
| 1 | Both Main-Link and Sub-Link active |

Table 3. Power Down Setting(THCV236)

| PDN1 | PDN0 | Operation |
|------|------|--|
| 0 | 0 | Both Main-Link and Sub-Link power down |
| 0 | 1 | Only Main-Link is active |
| 1 | 0 | Only Sub-Link is active |
| 1 | 1 | Both Main-Link and Sub-Link active |

Pre-emphasis and Drive Select Function (THCV231 only)

Pre-emphasis can equalize severe signal degradation caused by long-distance or high-speed transmission. PRE register selects the strength of pre-emphasis. CMLDRV register controls CML Main-Link output swing level. See Table 4.

Table 4. Pre-emphasis and Drive Select function table

| CMLDRV[1:0] (register) | PRE (register) | Condition | |
|---------------------------|-------------------|----------------|--------------------|
| | | Swing Level | Pre-emphasis Level |
| 00 | 0 | 400mV diff p-p | 0dB |
| | 1 | | 6dB |
| 01 | 0 | 600mV diff p-p | 0dB |
| | 1 | | 3.5dB |
| 10 | * | 800mV diff p-p | 0dB |
| 11 | * | Forbidden | |

Permanent Clock Output (THCV236 only)

When there is no input from Main-Link, the THCV236 will output internal oscillator clock from CLKOUT pin. This function is controlled by OUTSEL pin or OUTSEL_ENABLE register and OUTSEL_SETTING register. See Table 5.

Table 5. Permanent Clock Output function table (PDN1=1)

| OUTSEL_ENABLE (register) | OUTSEL_SETTING (register) | Output Clock Frequency(*1) |
|-----------------------------|------------------------------|----------------------------|
| 0 | * | - |
| 1 | 00 | 80MHz |
| | 01 | 40MHz(default) |
| | 10 | 20MHz |
| | 11 | 10MHz |

*1 typical value

Spread Spectrum Clock Generator (SSCG)

The THCV231 serial data output and the THCV236 parallel data and clock outputs are modulated by programmable SSCG. The THCV231 and THCV236 SSCG are enabled by only SSEN register. The modulation rate and modulation frequency variation of output spread is controlled through the SSCG control registers on each device. Do not enable spread spectrum for both the THCV231 and THCV236 at the same time.

Table 6. SSCG enable signal

| Mode Entry Signal | Description |
|-------------------|---------------------------------|
| SSEN(register) | 0:SSCG Disable 1:SSCG Enable |

When customer use the mode and frequency range shown in Table 7, register setting is required according to Table 8.

Table 7. Main-Link mode and frequency range requiring register setting

| Mode Setting | | | | Freq.Range[MHz] (SSCG Enable) | | Register Setting (*2) |
|--------------|-------|------|------|----------------------------------|------|--------------------------|
| MAINMODE | HFSEL | COL1 | COL0 | min | max | |
| 1 | 0 | 0 | 0 | 26.6 | 40 | Case1 |
| 1 | 0 | 0 | 1 | 26.6 | 50 | Case1 |
| 1 | 0 | 1 | 0 | 33.3 | 66.6 | Case2 |
| 1 | 1 | (*1) | (*1) | 50 | 100 | Case3 |

*1 Don't care
*2 See Table 8

Table 8. SSCG register setting

| Step | Register Address(HEX) | | Register Value(HEX) | | | | Description |
|------|-----------------------|---------------------|---------------------|-------|---------|---------|---------------------|
| | Sub-Link Master side | Sub-Link Slave side | Case1 | Case2 | Case3 | | |
| | | | | | THCV231 | THCV236 | |
| 1 | 0x70 | 0xF0 | 0x01 | | | | Set 1 to PLL_SET_EN |
| 2 | 0x76 | 0xF6 | 0x02 | | 0x02 | 0x01 | Set PLL_SET0 |
| 3 | 0x78 | 0xF8 | 0x3C | 0x30 | 0x20 | | Set PLL_SET1 |
| 4 | 0x7C | 0xFC | 0x35 | 0x34 | 0x24 | | Set PLL_SET2 |

Modulation frequency f_{mod} can be determined by HFSEL and LFSEL settings, input clock frequency and FMOD register setting (default value 0xD). Refer to following formula.

$$f_{mod} = \frac{f_{CLKSSCG}}{128 \times FMOD}$$

$f_{CLKSSCG}$ is the frequency listed in Table 9 and Table 10.

Table 9. $f_{CLKSSCG}$ (THCV231)

| HFSEL (register) | $f_{CLKSSCG}$ |
|---------------------|------------------|
| 0 | $(1/t_{TCIP})/2$ |
| 1 | $(1/t_{TCIP})/4$ |

Table 10. $f_{CLKSSCG}$ (THCV236)

| HFSEL | LFSEL | $f_{CLKSSCG}$ |
|-------|-------|-------------------|
| 0 | 0 | $(1/t_{RCP})/2$ |
| 1 | 0 | $(1/t_{RCP})/4$ |
| * | 1 | Forbidden Setting |

Up to 0.5 % spread at the 30kHz modulation frequency is stable for most cases. In case of using out of this range, please verify at the actual system.

Hot-Plug Function

HTPDN signal indicates connecting condition between the Transmitter and the Receiver. HTPDN of the transmitter side is high when the Receiver is not active or not connected. Then the Transmitter can enter into the power down mode. HTPDN is set to low by the Receiver when the Receiver is active and connects to the Transmitter, and then the Transmitter must start up and transmit CDR training pattern for link training.

HTPDN is transferred to the Transmitter via Sub-Link line. HOST MPU can confirm HTPDN state by reading Sub-Link Master register (0x00 bit0 HTPDN).

Lock Detect Function

LOCKN indicates whether the receiver CDR PLL is in the lock state or not. LOCKN at the Transmitter input is set to High when the Receiver is not active or at the CDR PLL training state. LOCKN is set to low by the Receiver when CDR lock is done. Then the CDR training mode finishes and the Transmitter shifts to the normal operation.

LOCKN is transferred via Sub-Link line. HOST MPU can confirm LOCKN state by reading Sub-Link Master register (0x00 bit1 LOCKN).

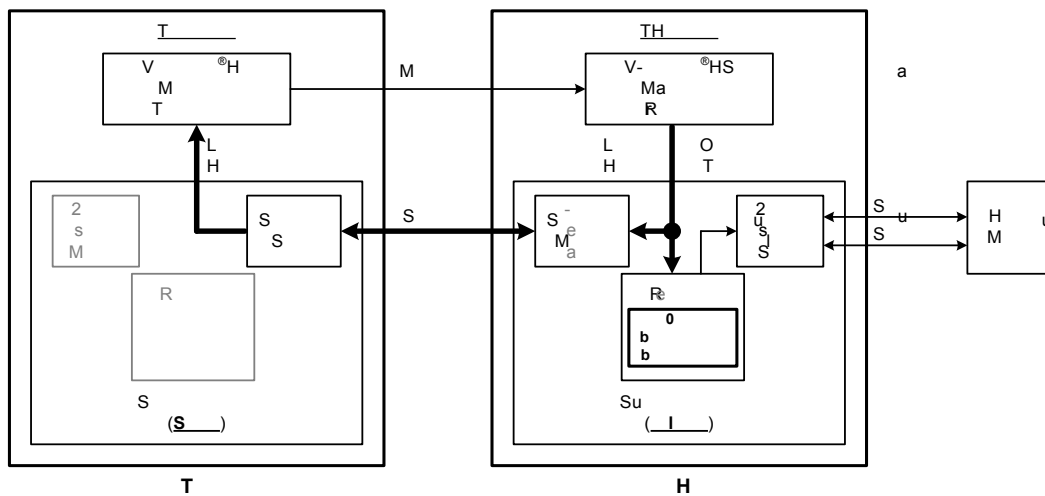

Figure 2. HTPDN, LOCKN transmission route

Field BET Operation

In order to help users to check validity of CML serial line (Main-Link and Sub-Link), the THC231 and THC236 have an operation mode in which they act as a bit error tester (BET). In Main-Link Field BET mode, the THC231 internally generates a test pattern which is then serialized onto the Main-Link CML line. The THC236 also has BET function mode. The THC236 receives the data stream and checks bit errors. The generated data pattern is then 8b/10b encoded, scrambled, and serialized onto the CML channel. As for the THC236, the internal test pattern check circuit gets enabled and reports result on a certain pin named BETOUT. In Sub-Link Field BET mode, Sub-Link Master device internally generates test pattern which is then serialized onto the Sub-Link CML line. Sub-Link Slave device also has BET function mode. Sub-Link Slave device receives the data stream and checks bit errors. Note that Sub-Link Slave device must be set this mode prior to Sub-Link Master device. Pattern check result is output from BETOUT pin of the Sub-Link Slave device. The BETOUT pin goes LOW whenever bit errors occur, or it stays HIGH when there is no bit error.

In Main-Link Field BET mode, user can select two kinds of check result, latched result or NOT latched result by setting LATEN pin input. The latched result is reset by setting LATEN=0. In Sub-Link Field BET mode, only latched result is available. In order to reset the latched result, please once turn off the power and entry Sub-Link Field BET from power on sequence.

GPIO4 pin (THC231) and LATEN/SD3/AIN1/GPIO0 pin (THC236) function as LATEN in Field BET mode (Main-Link or Sub-Link).

It is not possible to realize Main-Link Field BET and Sub-Link Field BET at the same time.

Table 11. Main-Link Field BET Operation Settings

| THCV231/236 Common Setting | | | | THCV236 Setting | Condition | | |
|-------------------------------|---------|-----------|-----------|--------------------|---------------------|------------------|---------------------|
| PDN0/PDN1/PDN | SUBMODE | BET | BET_SEL | LATEN | Main-Link | Sub-Link | Output Latch Select |
| 1 | 0 | 1 (*1) | 0 (*2) | 0 | Field BET Operation | Normal Operation | NOT Latched Result |
| | | | | 1 | | | Latched Result |

*1 THC231: Register setting (0x53 bit1), THC236: Pin setting

*2 Register setting (0x53 bit0, Default 0)

Table 12. THC236 Main-Link Field BET Result

| BETOUT | Output |
|--------|--------------------|
| L | Bit Error Occurred |
| H | No Error |

Table 13. Sub-Link Field BET Operation Setting

| THCV231/THCV236 Common Setting | | THCV231 Setting | | | THCV236 Setting | | | Condition | |
|--------------------------------|---------|-----------------|-------|--------|-----------------|-------|--------|---------------------------------------|---------------------|
| BET | BET_SEL | PDN | GPIO3 | GPIO4 | PDN1 | MSSEL | LATEN | Sub-Link | Output Latch Select |
| 1 (*1) | 1 (*2) | 1 | 0 | - | 1 | 1 | 1 (*3) | Field BET Operation (THCV231→THCV236) | Latched Result |
| | | | 1 | 1 (*3) | | 0 | - | Field BET Operation (THCV236→THCV231) | |

*1 THCV231: Register setting (0x53 bit1), THCV236: Pin setting. Note that BET pin should be 0 at power on sequence.

*2 Register setting (0x53 bit0, Default 0)

*3 Forbidden 0 setting

Table 14. Sub-Link Slave device Sub-Link Field BET Result

| BETOUT | Output |
|--------|--------------------|
| L | Bit Error Occurred |
| H | No Error |

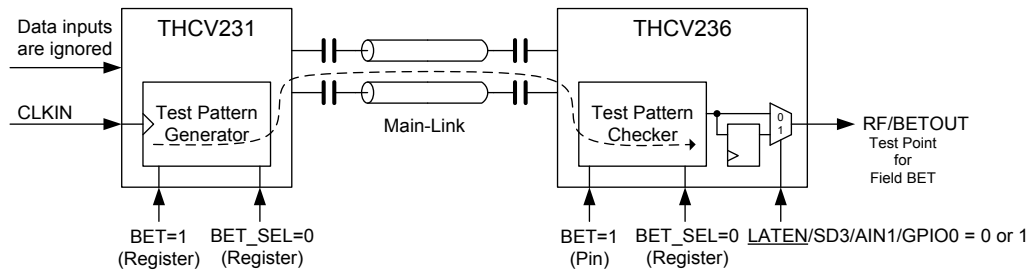

Figure 3. Main-Link Field BET Configuration

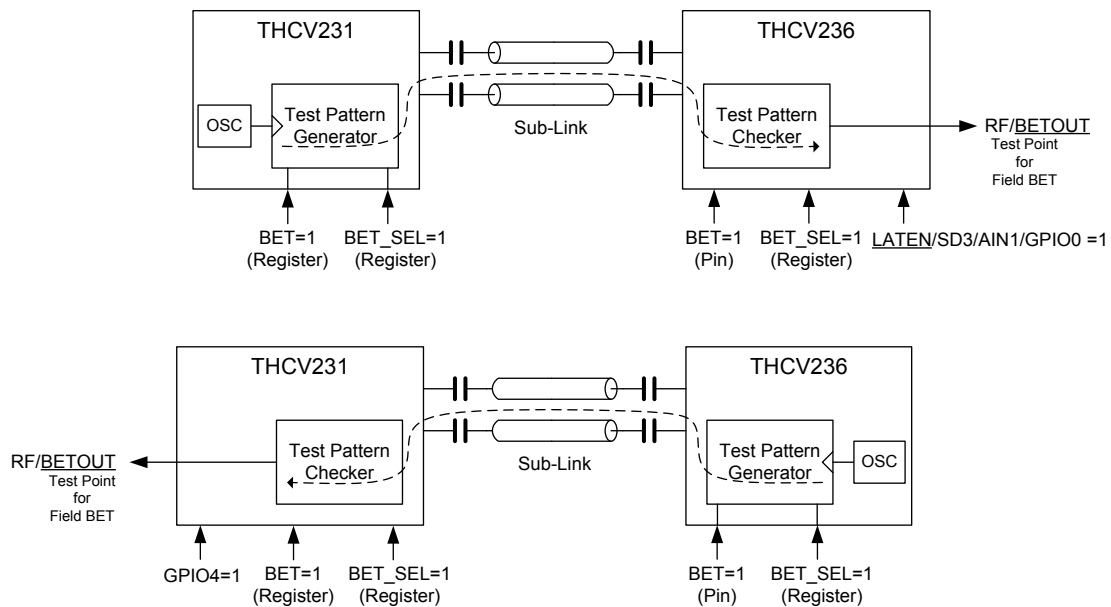

Figure 4. Sub-Link Field BET Configuration

Data Width and Frequency Range Select Function

The THCV231 and THCV236 support a variety of data width and frequency range. Frequency range is different depending on the mode setting SSCG enable and disable setting. Refer to Table 15 for details.

Table 15. Main-Link Operation Mode Select

| Mode Setting | | | | Freq.Range [MHz] | | | | Main-Link CML Bit Rate | Data Width | Comment |
|--------------|-------|------|------|------------------|-----|------------------|-----|------------------------|------------|---------|
| | | | | SSCG Disable | | SSCG Enable (*1) | | | | |
| MAINMODE | HFSEL | COL1 | COL0 | min | max | min | max | | | |
| 0 | * | * | * | - | - | - | - | - | Forbidden | |
| 1 | 0 | 0 | 0 | 12 | 30 | 26.6 | 60 | x50 | 14 | |
| 1 | 0 | 0 | 1 | 15 | 40 | 26.6 | 75 | x40 | 14 | |
| 1 | 0 | 1 | 0 | 20 | 75 | 33.3 | 100 | x30 | 14 | |
| 1 | 0 | 1 | 1 | - | - | - | - | - | Forbidden | |
| 1 | 1 | 0 | 0 | - | - | - | - | - | Forbidden | |
| 1 | 1 | 0 | 1 | 50 | 70 | 50 | 70 | x20 | 14 | (*)2 |
| | | | | 70 | 160 | 70 | 160 | | | |
| 1 | 1 | 1 | 0 | 50 | 70 | 50 | 70 | x15 | 10 | (*)2 |
| | | | | 70 | 160 | 70 | 160 | | | |
| 1 | 1 | 1 | 1 | - | - | - | - | - | Forbidden | |

*1 Note that register setting is required depending on the mode setting and used frequency range. See Table 7.

*2 Register setting is required. See Table 16.

Table 16. Register setting (HFSEL=1 and Frequency range is from 50MHz to 70MHz)

| Step | Register Address(HEX) | | Register Value(HEX) | | Description |
|------|-----------------------|---------------------|---------------------|---------|---------------------|
| | Sub-Link Master side | Sub-Link Slave side | THCV231 | THCV236 | |
| 1 | 0x70 | 0xF0 | 0x01 | | Set 1 to PLL_SET_EN |
| 2 | 0x76 | 0xF6 | 0x02 | 0x01 | Set PLL_SET0 |
| 3 | 0x78 | 0xF8 | 0x20 | | Set PLL_SET1 |
| 4 | 0x7C | 0xFC | 0x24 | | Set PLL_SET2 |

Data Mapping

Table 17. Data Mapping

| | | | | | | | | | |
|-----------|---|-------|-------|-------|---|---|----------|--------|---|
| MAINMODE | 0 | 1 | 1 | 1 | 1 | 1 | 1 | 1 | 1 |
| HFSEL | * | 0 | 0 | 0 | 0 | 1 | 1 | 1 | 1 |
| COL1 | * | 0 | 0 | 1 | 1 | 0 | 0 | 1 | 1 |
| COL0 | * | 0 | 1 | 0 | 1 | 0 | 1 | 0 | 1 |
| D0 | - | D0 | D0 | D0 | - | - | D0/RAW4 | D0/YC0 | - |
| D1 | - | D1 | D1 | D1 | - | - | D1/RAW5 | D1/YC1 | - |
| D2 | - | D2 | D2 | D2 | - | - | D2/RAW6 | D2/YC2 | - |
| D3 | - | D3 | D3 | D3 | - | - | D3/RAW7 | D3/YC3 | - |
| D4 | - | D4 | D4 | D4 | - | - | D4/RAW8 | D4/YC4 | - |
| D5 | - | D5 | D5 | D5 | - | - | D5/RAW9 | D5/YC5 | - |
| D6 | - | D6 | D6 | D6 | - | - | D6/RAW10 | D6/YC6 | - |
| D7 | - | D7 | D7 | D7 | - | - | D7/RAW11 | D7/YC7 | - |
| D8 | - | D8 | D8 | D8 | - | - | D8/RAW0 | - | - |
| D9 | - | D9 | D9 | D9 | - | - | D9/RAW1 | - | - |
| D10 | - | D10 | D10 | D10 | - | - | D10/RAW2 | - | - |
| D11 | - | D11 | D11 | D11 | - | - | D11/RAW3 | - | - |
| HSYNC(*1) | - | HSYNC | HSYNC | HSYNC | - | - | HSYNC | HSYNC | - |
| VSYNC(*1) | - | VSYNC | VSYNC | VSYNC | - | - | VSYNC | VSYNC | - |

*1 Any signal as well as sync signal can be transmitted.

Sub-Link Mode Setting

2-wire serial I/F Mode

2-wire serial I/F Mode enables register access, using GPIO (General Purpose Input/Output) pin and interrupt function. Sub-Link Master device has 2-wire serial slave block and can be connected to HOST MPU, Sub-Link Slave device has 2-wire serial master block and can be connected to remote side 2-wire serial slave devices.

HOST MPU can access register of Sub-Link Master device, Sub-Link Slave device and remote side 2-wire serial slave devices.

2-wire serial I/F Device ID setting

AIN1 and AIN0 pins determine Device ID setting of the THCV236. Only Sub-Link Master device has AIN1 and AIN0 pin. AIN1 and AIN0 choose one of 4 addresses which give an identification address to the THCV236 under 2-wire serial interface bus topology.

Table 18. 2-wire serial I/F Device ID select (Sub-Link Master device Only)

| AIN1 | AIN0 | Device ID |
|------|------|-----------|
| 0 | 0 | 0x0B |
| 0 | 1 | 0x34 |
| 1 | 0 | 0x77 |
| 1 | 1 | 0x65 |

2-wire serial I/F Clock Stretching

In principle, when Sub-Link bridges 2-wire serial interface communication from Sub-Link Master to Sub-Link Slave or remote side 2-wire serial slave devices, time lag occurs between HOST MPU side 2-wire serial access and Sub-Link Slave internal bus access or remote side 2-wire serial access.

2WIRE_MODE (Sub-Link Master side register, 0x0F bit1-0) selects whether 2-wire serial slave of Sub-Link Master perform clock stretching or not.

When 2WIRE_MODE = 00, Sub-Link Master device wait HOST MPU until Sub-Link Slave register access or remote side 2-wire serial slave register access is completed by clock stretching.

When 2WIRE_MODE = 01, Sub-Link Master device informs HOST MPU that Sub-Link Slave register access or remote side 2-wire serial register access has been completed by interruption (INT pin) without clock stretching.

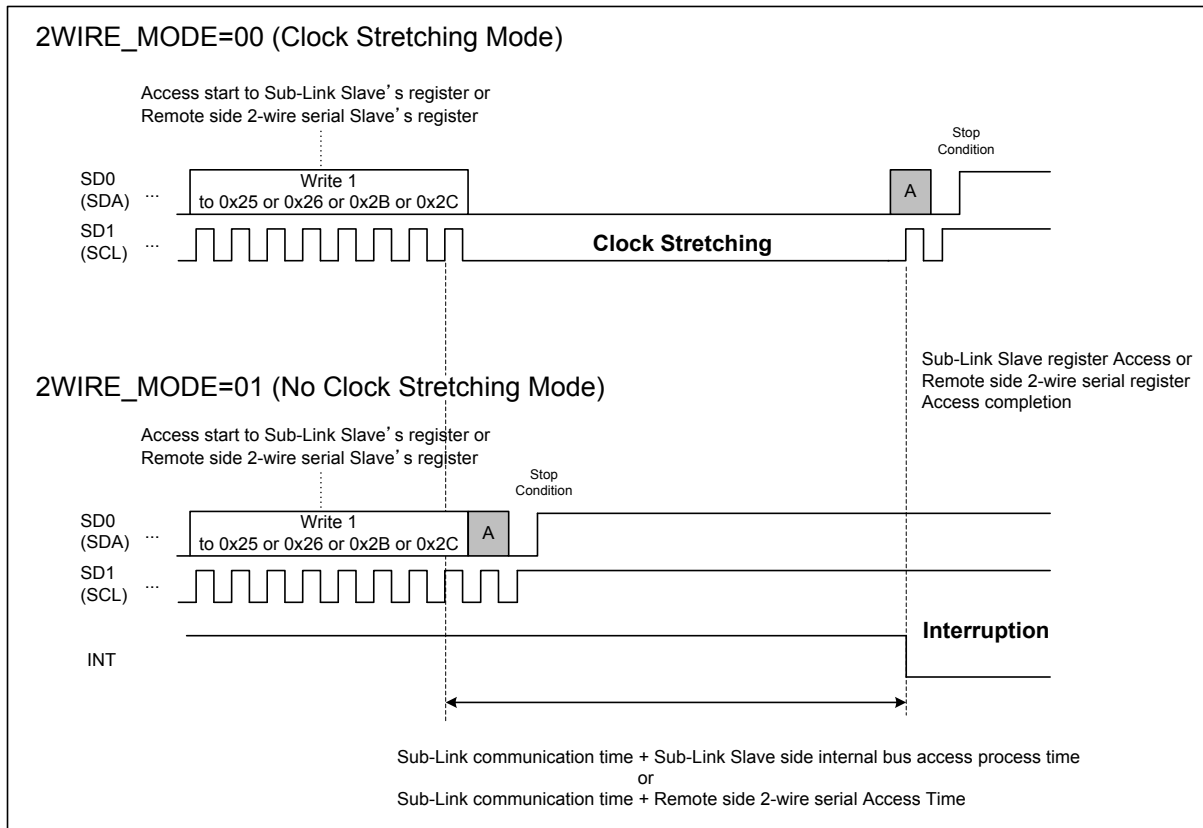

Figure 5. 2WIRE_MODE Operation

Read/Write access to Sub-Link Master Register

HOST MPU can directly access Sub-Link Master's register by 2-wire serial I/F.

Register address of Sub-Link Master is from 0x00 to 0x7F. See **Register Map** for more information.

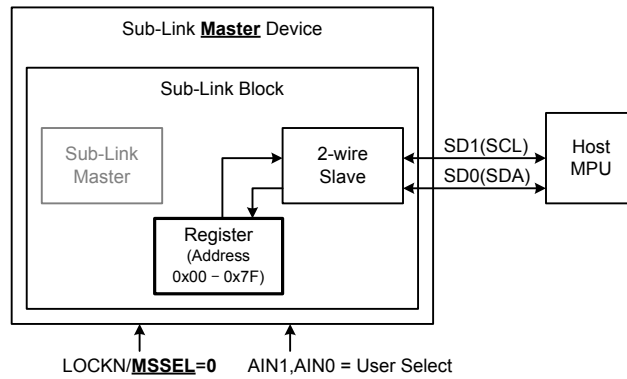

Figure 6. Host to Sub-Link Master Register access configuration

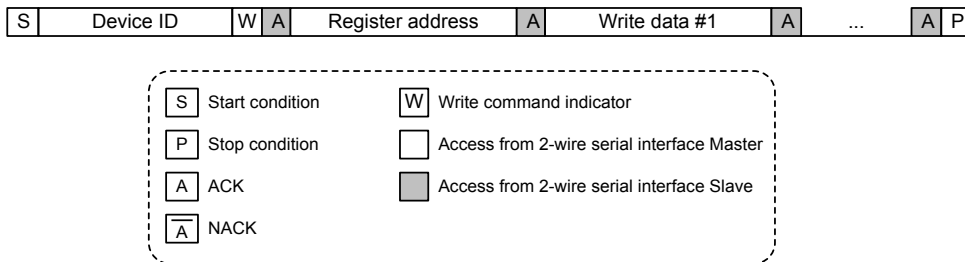

Figure 7. 2-wire serial I/F write to Sub-Link Master register protocol

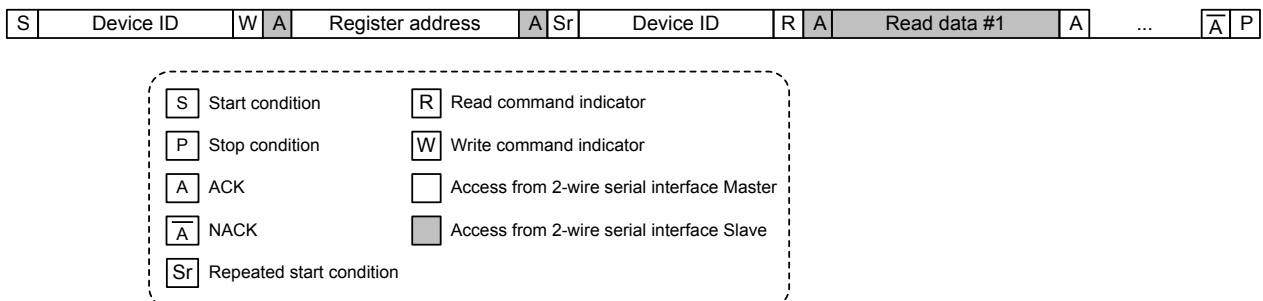

Figure 8. 2-wire serial I/F read to Sub-Link Master register protocol

Read/Write access to Sub-Link Slave Register

HOST MPU can access to Sub-Link Slave’s register via Sub-Link Master by Sub-Link Master register settings. Register address of Sub-Link Slave is from 0x80 to 0xFF. See **Register Map** for more information.

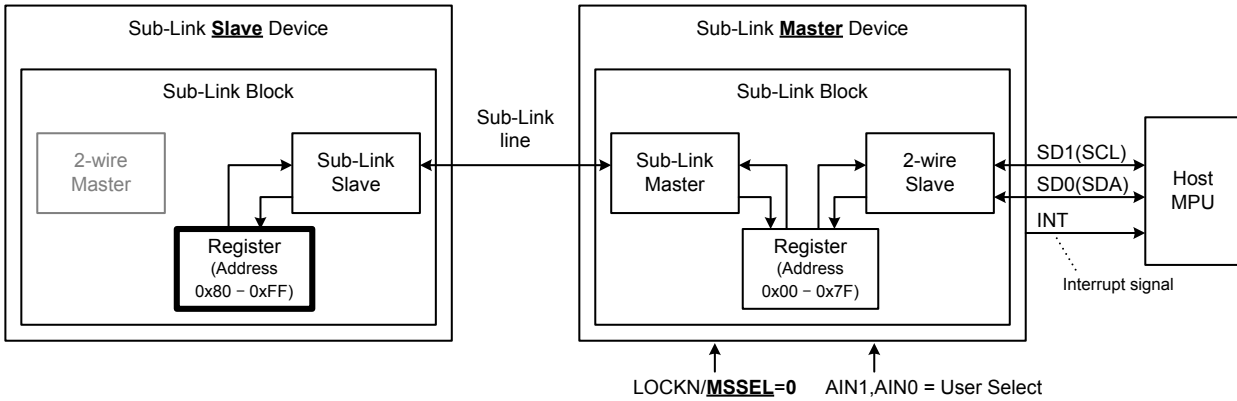

Figure 9. Host MPU to Sub-Link Slave Register access configuration

Table 19. Sub-Link slave register Write Procedure

| Step | Description | R/W | Address |
|------|---|-----|-----------|
| 1 | Write 1 or 0 and clear(auto clear) access status register (2WIRE_ACS_END_INT). | W | 0x02 bit7 |
| 2 | Set the data for Sub-Link Slave to write (Max 16byte). | W | 0x10-0x1F |
| 3 | Set Device ID of Sub-Link Master device. (Value corresponding to AIN1 and AIN0 setting. e.g.[AIN1,AIN0]=[0,0] → 7'h0B) | W | 0x20 |
| 4 | Set the byte number written to Sub-Link Slave (Max 16byte). (Byte number = register value + 1) | W | 0x21 |
| 5 | Set the start address of Sub-Link Slave register to write. | W | 0x23 |
| 6 | Write 1 to WR_START_8B. (Start write access to Sub-Link Slave register) | W | 0x25 (*1) |
| 7 | 2-wire serial slave of Sub-Link Master perform clock stretching until Sub-Link Slave register access is completed. | - | - |
| 7 | When write access is completed, 2WIRE_ACS_END_INT register value become 1 and interrupt occurs (INT=H → L). | - | - |
| 8 | If write access was normally ended, read value should be "0x1". | R | 0x02 bit7 |

*1 It's Prohibit that HOST MPU start access to Sub-Link Slave or remote 2-wire serial slave before the previous access to Sub-Link Slave or remote side 2-wire serial slave is completed.

*2 When 2WIRE_MODE = 00 (Clock Stretching Mode)

*3 When 2WIRE_MODE = 01 (No Clock Stretching Mode)

Table 20. Sub-Link slave register Read Procedure

| Step | Description | R/W | Address |
|-----------|--|-----|-----------|
| 1 | Write 1 or 0 and clear(auto clear) access status register (2WIRE_ACS_END_INT). | W | 0x02 bit7 |
| 2 | Set Device ID of Sub-Link Master device. (Value corresponding to AIN1 and AIN0 setting. e.g. [AIN1,AIN0]=[0,0] → 7'h0B) | W | 0x20 |
| 3 | Set the byte number read from Sub-Link Slave(Max 16byte). (Byte number = register value + 1) | W | 0x22 |
| 4 | Set the start address of Sub-Link Slave register to read. | W | 0x24 |
| 5 | Write 1 to RD_START_8B. (Start read access to Sub-Link Slave register) | W | 0x26 (*1) |
| 6 (*2) | 2-wire serial slave of Sub-Link Master perform clock stretching until Sub-Link Slave register access is completed. When read access is completed, SCL is released and read data is stored in Sub-Link Master register (Address 0x10-0x1F). | - | - |
| 6 (*3) | When read access is completed, read data is stored in Sub-Link Master register (Address 0x10-0x1F) and 2WIRE_ACS_END_INT register value become 1 and interrupt occurs (INT=H → L). | - | - |
| 7 | If read access was normally ended, read value should be "0x1". | R | 0x02 |
| 8 | HOST MPU read data stored in Sub-Link Master register. | R | 0x10-0x1F |

*1 It's Prohibit that HOST MPU start access to Sub-Link Slave or remote 2-wire serial slave before the previous access to Sub-Link Slave or remote side 2-wire serial slave is completed.

*2 When 2WIRE_MODE = 00 (Clock Stretching Mode)

*3 When 2WIRE_MODE = 01 (No Clock Stretching Mode)

Read/Write access to remote side 2-wire serial slave devices connected to Sub-Link Slave Device

HOST MPU can access to remote side 2-wire serial slave register via Sub-Link Master and Sub-Link Slave by Sub-Link Master register settings. Sub-Link Slave has 2-wire serial master block. Up to 8 devices are connectable to 2-wire serial master of Sub-Link Slave device.

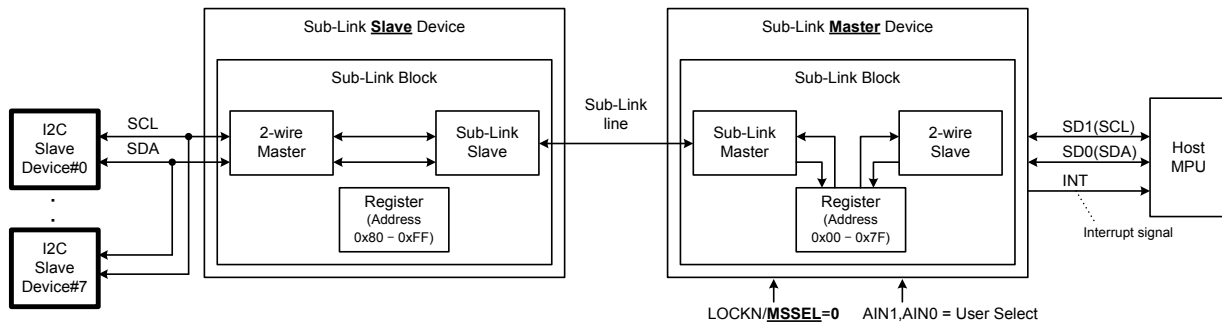

Figure 10. Host to 2-wire serial Slave devices connected to Sub-Link Slave device access configuration

Table 21. Remote side 2-wire serial slave register Write Procedure for 8bit register address

| Step | Description | R/W | Address |
|------|--|-----|-----------|
| 1 | Set slave address of remote side 2-wire serial slave device (Low-order 7bits), and enable this address (High-order 1bit). | W | 0x04-0x0B |
| 2 | Write 1 or 0 and clear(auto clear) access status register (2WIRE_ACS_END_INT). | W | 0x02 bit7 |
| 3 | Set the data for remote side 2-wire serial slave to write (Max 16byte). | W | 0x10-0x1F |
| 4 | Set slave address of access target 2-wire serial slave (choose the value set in 0x04-0x0B[6:0]), and set 0 to 0x20 bit7. | W | 0x20 |
| 5 | Set the byte number written to remote side 2-wire serial slave (Max 16byte). (Byte number = register value + 1) | W | 0x21 |
| 6 | Set the start address of remote side 2-wire serial slave register to write. | W | 0x23 |
| 7 | Write 1 to WR_START_8B. (Start write access to remote side 2-wire serial slave register) | W | 0x25 (*1) |
| 8 | 2-wire serial slave of Sub-Link Master perform clock stretching until remote side (*2) 2-wire serial slave register access is completed. | - | - |
| 8 | When write access is completed, 2WIRE_ACS_END_INT register value become 1 (*3) and interrupt occurs (INT=H → L). | - | - |
| 9 | If wire access was normally ended, read value should be "0x1". | R | 0x02 |
| 10 | Repeat from step2 to step9 if needed. | - | - |

*1 It's Prohibit that HOST MPU start access to Sub-Link Slave or remote 2-wire serial slave before the previous access to Sub-Link Slave or remote side 2-wire serial slave is completed.

*2 When 2WIRE_MODE = 00 (Clock Stretching Mode)

*3 When 2WIRE_MODE = 01 (No Clock Stretching Mode)

Table 22. Remote side 2-wire serial slave register Write Procedure for 16bit register address

| Step | Description | R/W | Address |
|-----------|---|-----|-----------|
| 1 | Set slave address of remote side 2-wire serial slave device (Low-order 7bits), and enable this address (High-order 1bit). | W | 0x04-0x0B |
| 2 | Write 1 or 0 and clear(auto clear) access status register (2WIRE_ACS_END_INT). | W | 0x02 bit7 |
| 3 | Set the data for remote side 2-wire serial slave to write (Max 16byte). | W | 0x10-0x1F |
| 4 | Set slave address of access target 2-wire serial slave (choose the value set in 0x04-0x0B[6:0]), and set 1 to 0x20 bit7. | W | 0x20 |
| 5 | Set the byte number written to remote side 2-wire serial slave (Max 16byte). (Byte number = register value + 1) | W | 0x21 |
| 6 | Set the low-order bits([7:0]) of start address of remote side 2-wire serial slave register to write. | W | 0x27 |
| 7 | Set the high-order bits([15:8]) of start address of remote side 2-wire serial slave register to write. | W | 0x28 |
| 8 | Write 1 to WR_START_16B. (Start write access to remote side 2-wire serial slave register) | W | 0x2B (*1) |
| 9 (*2) | 2-wire serial slave of Sub-Link Master perform clock stretching until remote side 2-wire serial slave register access is completed. | - | - |
| 9 (*3) | When write access is completed, 2WIRE_ACS_END_INT register value become 1 and interrupt occurs (INT=H → L). | - | - |
| 10 | If write access was normally ended, read value should be "0x1". | R | 0x02 |
| 11 | Repeat from step2 to step10 if needed. | - | - |

*1 It's Prohibit that HOST MPU start access to Sub-Link Slave or remote 2-wire serial slave before the previous access to Sub-Link Slave or remote side 2-wire serial slave is completed.

*2 When 2WIRE_MODE = 00 (Clock Stretching Mode)

*3 When 2WIRE_MODE = 01 (No Clock Stretching Mode)

Table 23. Remote side 2-wire serial slave register Read Procedure for 8bit register address

| Step | Description | R/W | Address |
|-----------|--|-----|-----------|
| 1 | Set slave address of remote side 2-wire serial slave device (Low-order 7bits), and enable this address (High-order 1bit). | W | 0x04-0x0B |
| 2 | Write 1 or 0 and clear(auto clear) access status register (2WIRE_ACS_END_INT). | W | 0x02 bit7 |
| 3 | Set slave address of access target 2-wire serial slave (choose the value set in 0x04-0x0B)(Low-order 7bits), and set 0 to 0x20 bit7. | W | 0x20 |
| 4 | Set the byte number read from remote side 2-wire serial slave(Max 16byte). (Byte number = register value + 1) | W | 0x22 |
| 5 | Set the start address of remote side 2-wire serial slave register to read. | W | 0x24 |
| 6 | Write 1 to RD_START_8B. (Start read access to remote side 2-wire serial slave register) | W | 0x26 (*1) |
| 7 (*2) | 2-wire serial slave of Sub-Link Master perform clock stretching until Sub-Link Slave register access is completed. When read access is completed, SCL is released and read data is stored in Sub-Link Master register (Address 0x10-0x1F). | - | - |
| 7 (*3) | When read access is completed, read data is stored in Sub-Link Master register (Address 0x10-0x1F) and 2WIRE_ACS_END_INT register value become 1 and interrupt occurs (INT=H → L). | - | - |
| 8 | If read access was normally ended, read value should be "0x1". | R | 0x02 |
| 9 | HOST MPU read data stored in Sub-Link Master register. | R | 0x10-0x1F |
| 10 | Repeat from step2 to step10 if needed. | - | - |

*1 It's Prohibit that HOST MPU start access to Sub-Link Slave or remote 2-wire serial slave before the previous access to Sub-Link Slave or remote side 2-wire serial slave is completed.

*2 When 2WIRE_MODE = 00 (Clock Stretching Mode)

*3 When 2WIRE_MODE = 01 (No Clock Stretching Mode)

Table 24. Remote side 2-wire serial slave register Read Procedure for 16bit register address

| Step | Description | R/W | Address |
|--------|--|-----|-----------|
| 1 | Set slave address of remote side 2-wire serial slave device (Low-order 7bits), and enable this address (High-order 1bit). | W | 0x04-0x0B |
| 2 | Write 1 or 0 and clear(auto clear) access status register (2WIRE_ACS_END_INT). | W | 0x02 bit7 |
| 3 | Set slave address of access target 2-wire serial slave (choose the value set in 0x04-0x0B)(Low-order 7bits), and set 1 to 0x20 bit7. | W | 0x20 |
| 4 | Set the byte number read from remote side 2-wire serial slave(Max 16byte). | W | 0x22 |
| 5 | Set the low-order bits([7:0]) of start address of remote side 2-wire serial slave register to read. | W | 0x29 |
| 6 | Set the high-order bits([15:8]) of start address of remote side 2-wire serial slave register to read. | W | 0x2A |
| 7 | Write 1 to RD_START_16B. (Start read access to remote side 2-wire serial slave register) | W | 0x2C (*1) |
| 8 (*2) | 2-wire serial slave of Sub-Link Master perform clock stretching until Sub-Link Slave register access is completed. When read access is completed, SCL is released and read data is stored in Sub-Link Master register (Address 0x10-0x1F). | - | - |
| 8 (*3) | When read access is completed, read data is stored in Sub-Link Master register (Address 0x10-0x1F) and 2WIRE_ACS_END_INT register value become 1 and interrupt occurs (INT=H → L). | - | - |
| 9 | If read access was normally ended, read value should be "0x1". | R | 0x02 |
| 10 | HOST MPU read data stored in Sub-Link Master register. | R | 0x10-0x1F |
| 11 | Repeat from step2 to step10 if needed. | - | - |

*1 It's Prohibit that HOST MPU start access to Sub-Link Slave or remote 2-wire serial slave before the previous access to Sub-Link Slave or remote side 2-wire serial slave is completed.

*2 When 2WIRE_MODE = 00 (Clock Stretching Mode)

*3 When 2WIRE_MODE = 01 (No Clock Stretching Mode)