



Chipsmall Limited consists of a professional team with an average of over 10 year of expertise in the distribution of electronic components. Based in Hongkong, we have already established firm and mutual-benefit business relationships with customers from,Europe,America and south Asia,supplying obsolete and hard-to-find components to meet their specific needs.

With the principle of “Quality Parts,Customers Priority,Honest Operation,and Considerate Service”,our business mainly focus on the distribution of electronic components. Line cards we deal with include Microchip,ALPS,ROHM,Xilinx,Pulse,ON,Everlight and Freescale. Main products comprise IC,Modules,Potentiometer,IC Socket,Relay,Connector.Our parts cover such applications as commercial,industrial, and automotives areas.

We are looking forward to setting up business relationship with you and hope to provide you with the best service and solution. Let us make a better world for our industry!



## Contact us

Tel: +86-755-8981 8866 Fax: +86-755-8427 6832

Email & Skype: info@chipsmall.com Web: www.chipsmall.com

Address: A1208, Overseas Decoration Building, #122 Zhenhua RD., Futian, Shenzhen, China





# RJ45 Integrated Connector

Gigabit, Single Port, Through Hole, Tap-up

MODEL NUMBER  
**TIC-L041-11**

- Meets IEEE 802.3 and ANSI X3.263
- Operating temperature: 0°C to +70°C
- Storage Temperature: -40°C to +85°C

Package Information			
Weight		Quantity	
weight/pcs (g)	weight/carton (kg)	quantity/tray (pcs)	quantity/carton (pcs)
7.2	3.4	50	250

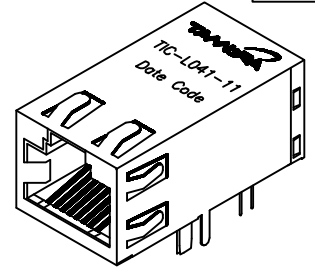

Electrical Specification @ 25°C								
Insertion Loss (dB Max)	Return Loss (dB Min)			CMRR (dB Min)	Crosstalk (dB Min)	OCV ( $\mu$ H Min)	Hipot (Vrms)	Impedance ( $\Omega$ )
1-100 MHz	1-30 MHz	60 MHz	80 MHz	1-100 MHz	1-100 MHz	8mA Dc Bias	1 minute	
-1	-18	-16	-12	-30	-35	350	1500	100

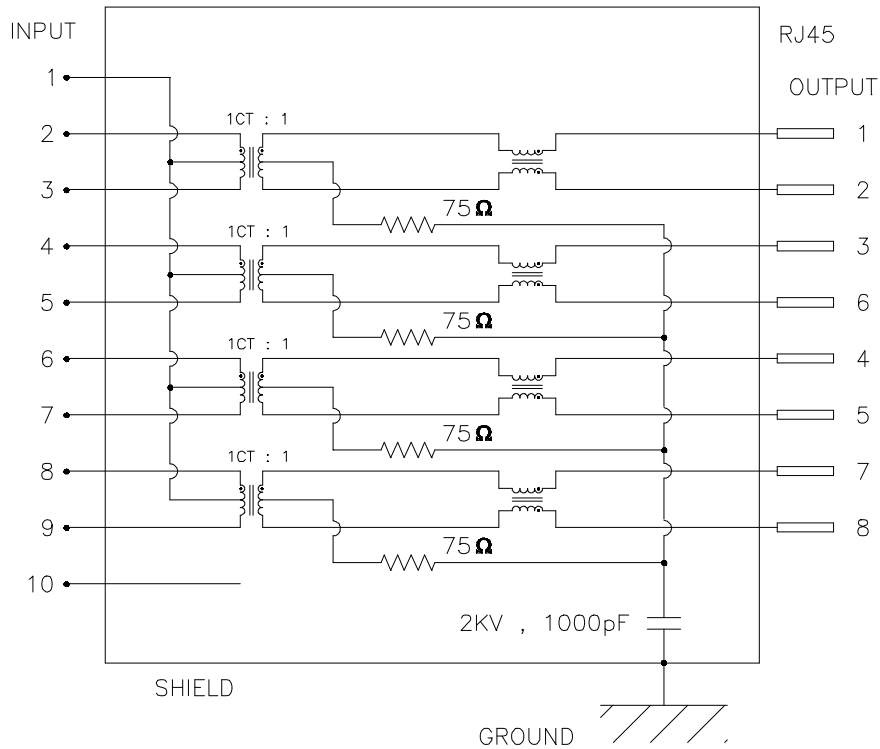

PREPARED BY:

D. Rund

ENGINEER:

L. Le

QUALITY CONTROL:

APPROVED:

J. Coleman

DWG CONTROL NO.  
P-A1-13060  
ACAD\TTC\A1130601.DWG

REV  
PRE

RJ45  
INTEGRATED CONNECTOR  
**TAMURA CORPORATION OF AMERICA**  
43352 BUSINESS PARK DRIVE, TEMECULA, CA. 92590-6624  
(909) 699-1270 FAX 9096769482

**TIC-L041-11**  
MODEL SPECIFICATION

DIM: mm(In) SCL: NONE SH: 1 OF 2

PROPRIETARY NOTICE: THIS DRAWING PRINT OR DOCUMENT AND SUBJECT MATTER DISCLOSED HEREIN ARE PROPRIETARY ITEMS TO WHICH TAMURA RETAINS THE EXCLUSIVE RIGHT OF DISSEMINATION, REPRODUCTION, MANUFACTURE AND SALE. THIS DRAWING, PRINT OR DOCUMENT IS SUBMITTED IN CONFIDENCE FOR CONSIDERATION BY THE RECIPIENT ALONE UNLESS PERMISSION FOR FURTHER DISCLOSURE IS EXPRESSLY GRANTED IN WRITING.



# RJ45 Integrated Connector

## Gigabit, Single Port, Through Hole, Tap-up

MODEL NUMBER  
**TIC-L041-11**

Mechanical Material Specification									
Contact							Plastic Part		Shell
RJ Contact				RJ Joint Contact			RJ Housing	Set Housing & Spacer Insert	Back
Contact Material	Contact Area	Solder Tail Area	Under-plating	Contact Material	Finish	Under-plating			
Phosphor Bronze	Gold	Tin/Lead (9:1)	Nickel	Brass	Tin/Lead (9:1)	Nickel	Thermoplastic, PC, Transparent	Thermoplastic PA6T, Black	Stainless SUS 304-1/2H
0.30 mm thick	30 μ" Min.	100 μ" Min.	50 μ" Min.	0.35mm thick	100 μ" Min.	50 μ" Min.	UL 94V-0	UL 94V-0	0.20 mm thick

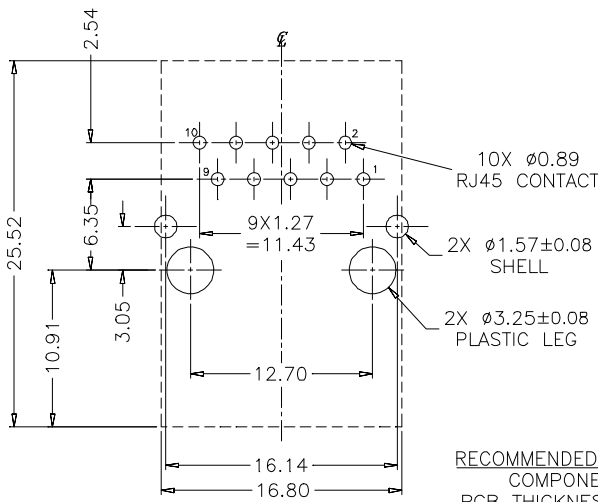

GENERAL TOLERANCE  
 .XX  $\pm 0.13$   
 .X  $\pm 0.25$

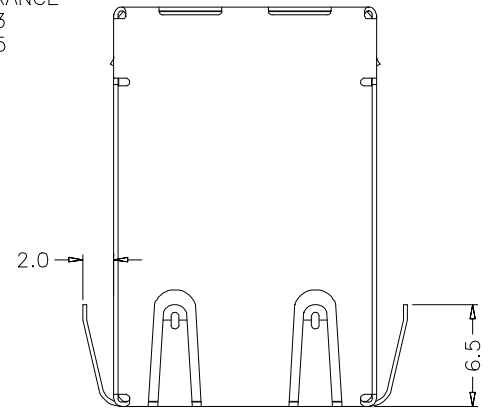

RECOMMENDED PCB LAYOUT  
 COMPONENT SIDE  
 PCB THICKNESS : 1.60mm  
 ALL DIMENSION TOLERANCE ARE  $\pm 0.05$   
 UNLESS OTHERWISE SPECIFIED

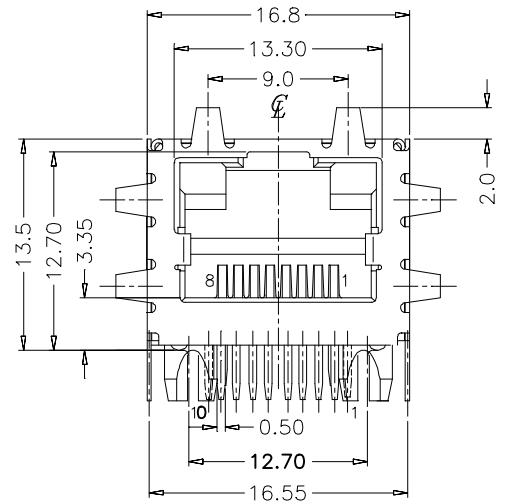
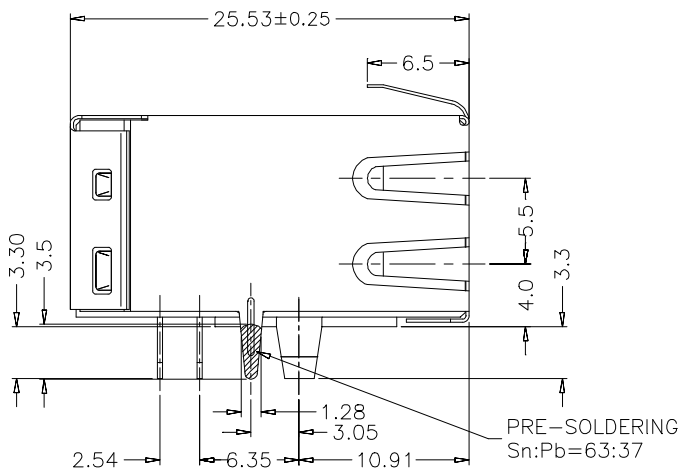

PREPARED BY:

D. Rund

ENGINEER:

L. Le

QUALITY CONTROL:

APPROVED:

J. Coleman

DWG CONTROL NO.  
 P-A1-13060  
 ACAD\TTC\A1130602.DWG

REV  
**PRE**

RJ45  
 INTEGRATED CONNECTOR

**TAMURA CORPORATION OF AMERICA**  
 43352 BUSINESS PARK DRIVE, TEMECULA, CA. 92590-6624  
 (909) 699-1270 FAX 9096769482

**TIC-L041-11**

MODEL SPECIFICATION

DIM: mm(In) SCL: NONE SH: 2 OF 2

PROPRIETARY NOTICE: THIS DRAWING PRINT OR DOCUMENT AND SUBJECT MATTER DISCLOSED HEREIN ARE PROPRIETARY ITEMS TO WHICH TAMURA RETAINS THE EXCLUSIVE RIGHT OF DISSEMINATION, REPRODUCTION, MANUFACTURE AND SALE. THIS DRAWING, PRINT OR DOCUMENT IS SUBMITTED IN CONFIDENCE FOR CONSIDERATION BY THE RECIPIENT ALONE UNLESS PERMISSION FOR FURTHER DISCLOSURE IS EXPRESSLY GRANTED IN WRITING.