



Chipsmall Limited consists of a professional team with an average of over 10 year of expertise in the distribution of electronic components. Based in Hongkong, we have already established firm and mutual-benefit business relationships with customers from,Europe,America and south Asia,supplying obsolete and hard-to-find components to meet their specific needs.

With the principle of “Quality Parts,Customers Priority,Honest Operation,and Considerate Service”,our business mainly focus on the distribution of electronic components. Line cards we deal with include Microchip,ALPS,ROHM,Xilinx,Pulse,ON,Everlight and Freescale. Main products comprise IC,Modules,Potentiometer,IC Socket,Relay,Connector.Our parts cover such applications as commercial,industrial, and automotives areas.

We are looking forward to setting up business relationship with you and hope to provide you with the best service and solution. Let us make a better world for our industry!



Contact us

Tel: +86-755-8981 8866 Fax: +86-755-8427 6832

Email & Skype: info@chipsmall.com Web: www.chipsmall.com

Address: A1208, Overseas Decoration Building, #122 Zhenhua RD., Futian, Shenzhen, China





TIM320-1131000

TiM3xx

2D LIDAR SENSORS

SICK
Sensor Intelligence.



Ordering information

Type	Part no.
TIM320-1131000	1062219

Other models and accessories → www.sick.com/TiM3xx



Detailed technical data

Features

Application	Indoor
Light source	Infrared (850 nm)
Laser class	1 (IEC 60825-1:2014, EN 60825-1:2014)
Aperture angle	270°
Scanning frequency	15 Hz
Angular resolution	1°
Operating range	0.05 m ... 4 m
Max. range with 10 % reflectivity	2 m

Performance

Response time	Typ. 134 ms
Detectable object shape	Almost any
Systematic error	± 40 mm ¹⁾
Statistical error	30 mm ¹⁾
Integrated application	Field evaluation with flexible fields
Number of field sets	16 field triples (48 fields, 1 triple (3 flexible fields) can be configured directly at the scanner)
Simultaneous evaluation cases	1 (3 fields)

¹⁾ Typical value; actual value depends on environmental conditions.

Interfaces

USB	✓
Remark	Micro USB
Function	AUX, parameterization
Switching inputs	4
Switching outputs	3 (PNP, additional 1 x "Device Ready")
Delay time	134 ms ... 30,000 ms (configurable)
Dwell time	67 ms ... 10,000 ms (configurable)
Optical indicators	2 LEDs (ON, switching status)

Mechanics/electronics

Electrical connection	1 x M12 12-pin male connector (0.8 m)
Operating voltage	9 V DC ... 28 V DC
Power consumption	Typ. 4 W
Housing color	Light blue (RAL 5012)
Enclosure rating	IP65 (IEC 60529:1989+AMD1:1999+AMD2:2013)
Protection class	III (IEC 61140:2016-1)
Weight	150 g, without connecting cables
Dimensions (L x W x H)	60 mm x 60 mm x 79 mm

Ambient data

Object remission	4 % ... > 1,000 % (reflectors)
Electromagnetic compatibility (EMC)	IEC 61000-6-3:2006+AMD1:2010 / IEC 61000-6-2:2005
Vibration resistance	IEC 60068-2-6:2007
Shock resistance	IEC 60068-2-27:2008
Ambient operating temperature	-10 °C ... +50 °C
Storage temperature	-30 °C ... +70 °C
Ambient light immunity	15,000 lx

General notes

Note on use	The sensor does not constitute a safety component as defined by relevant legislation on machine safety.
--------------------	---

Classifications

ECl@ss 5.0	27270990
ECl@ss 5.1.4	27270990
ECl@ss 6.0	27270913
ECl@ss 6.2	27270913
ECl@ss 7.0	27270913
ECl@ss 8.0	27270913
ECl@ss 8.1	27270913
ECl@ss 9.0	27270913
ETIM 5.0	EC002550
ETIM 6.0	EC002550
UNSPSC 16.0901	46171620

Dimensional drawing (Dimensions in mm (inch))

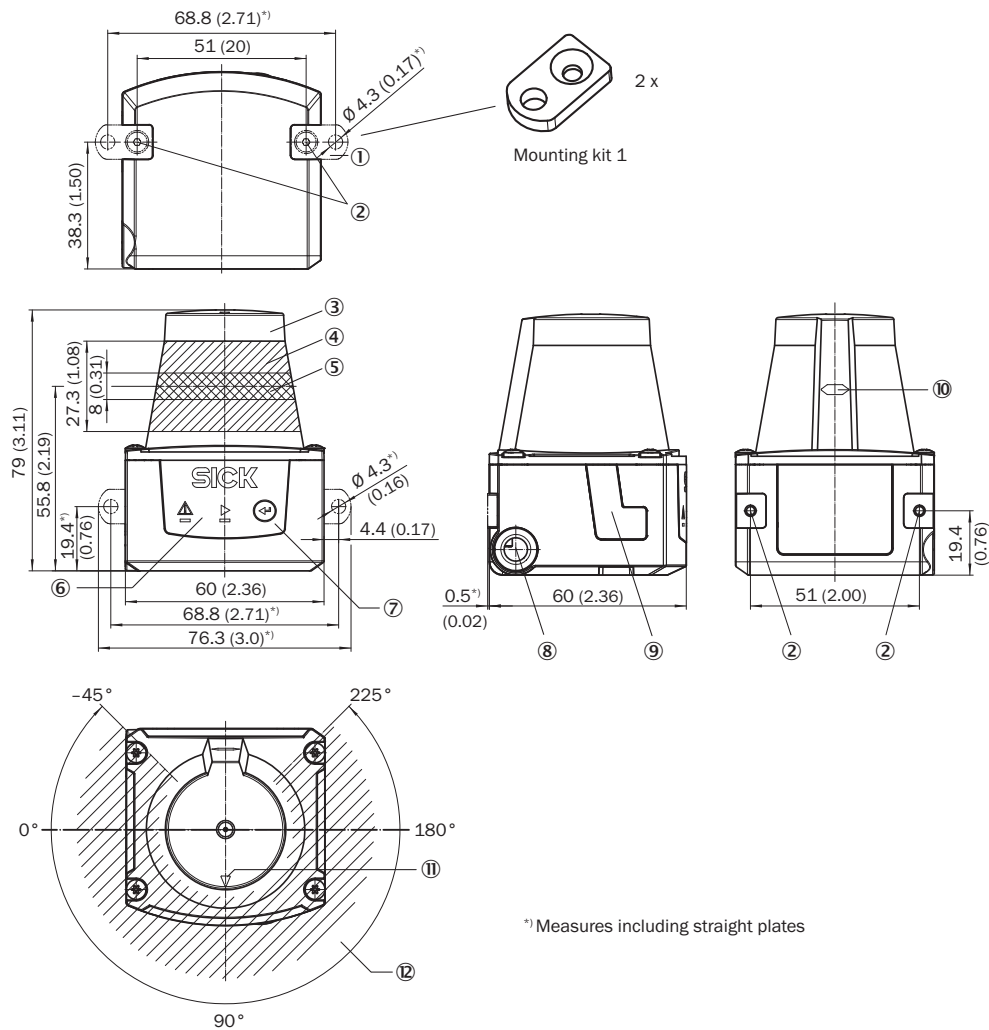

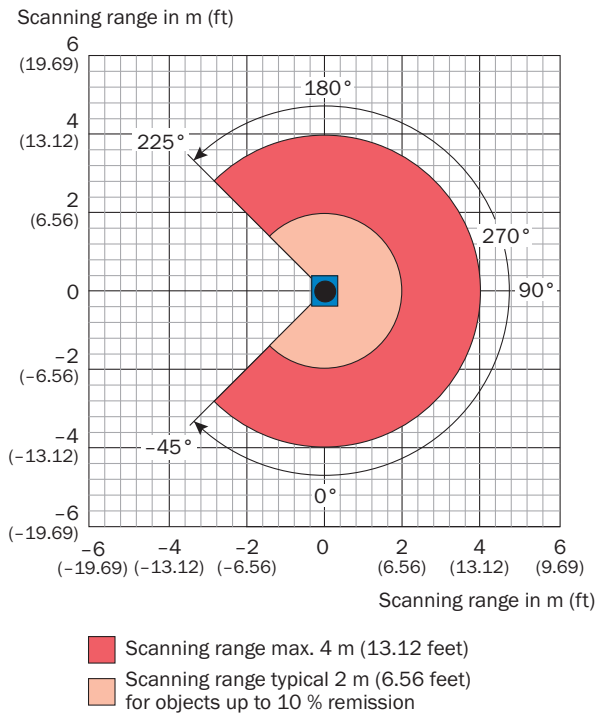

- ① 2 x straight plates with M3 x 4 mm screw (included in delivery)
- ② M3 threaded mounting hole, 2.8 mm deep (blind hole thread)
- ③ Optical hood
- ④ Receiving range (light inlet)
- ⑤ Transmission range (light emission)
- ⑥ Red and green LED (status displays)
- ⑦ Function button for teach-in
- ⑧ Connecting cable exit ("power/switching inputs/outputs" connection)
- ⑨ Micro USB female connector, type B
- ⑩ Marking for the position of the light emission level
- ⑪ Bearing marking to support alignment (90° axis)
- ⑫ Aperture angle 270° (scanning angle)

Operating range diagram



Recommended accessories

Other models and accessories → www.sick.com/TiM3xx

	Brief description	Type	Part no.
Mounting brackets and plates			
	Mounting set 2, fender and alignment aid	Mounting kit 2	2061776
Plug connectors and cables			
	Head A: female connector, M12, 12-pin, straight, A-coded Head B: open cable ends Cable: Power, I/O, PUR, shielded, 5 m	Connecting cable (female connector - open)	6054974

SICK AT A GLANCE

SICK is one of the leading manufacturers of intelligent sensors and sensor solutions for industrial applications. A unique range of products and services creates the perfect basis for controlling processes securely and efficiently, protecting individuals from accidents and preventing damage to the environment.

We have extensive experience in a wide range of industries and understand their processes and requirements. With intelligent sensors, we can deliver exactly what our customers need. In application centers in Europe, Asia and North America, system solutions are tested and optimized in accordance with customer specifications. All this makes us a reliable supplier and development partner.

Comprehensive services complete our offering: SICK LifeTime Services provide support throughout the machine life cycle and ensure safety and productivity.

For us, that is “Sensor Intelligence.”

WORLDWIDE PRESENCE:

Contacts and other locations www.sick.com