



Chipsmall Limited consists of a professional team with an average of over 10 year of expertise in the distribution of electronic components. Based in Hongkong, we have already established firm and mutual-benefit business relationships with customers from,Europe,America and south Asia,supplying obsolete and hard-to-find components to meet their specific needs.

With the principle of "Quality Parts,Customers Priority,Honest Operation,and Considerate Service",our business mainly focus on the distribution of electronic components. Line cards we deal with include Microchip,ALPS,ROHM,Xilinx,Pulse,ON,Everlight and Freescale. Main products comprise IC,Modules,Potentiometer,IC Socket,Relay,Connector.Our parts cover such applications as commercial,industrial, and automotives areas.

We are looking forward to setting up business relationship with you and hope to provide you with the best service and solution. Let us make a better world for our industry!



## Contact us

Tel: +86-755-8981 8866 Fax: +86-755-8427 6832

Email & Skype: info@chipsmall.com Web: www.chipsmall.com

Address: A1208, Overseas Decoration Building, #122 Zhenhua RD., Futian, Shenzhen, China





# TIP41A TIP42A

## COMPLEMENTARY SILICON POWER TRANSISTOR

### Features

- COMPLEMENTARY PNP-NPN DEVICES
- NEW ENHANCED SERIES
- HIGH SWITCHING SPEED
- $h_{FE}$  IMPROVED LINEARITY

### Applications

- GENERAL PURPOSE CIRCUITS
- AUDIO AMPLIFIER
- POWER LINEAR AND SWITCHING

### Description

The TIP41A is a silicon base island technology NPN power transistor Jedec TO-220 plastic package with improved performances than the industry standard TIP41A that make this device suitable for audio, power linear and switching applications. The complementary PNP type is TIP42A.

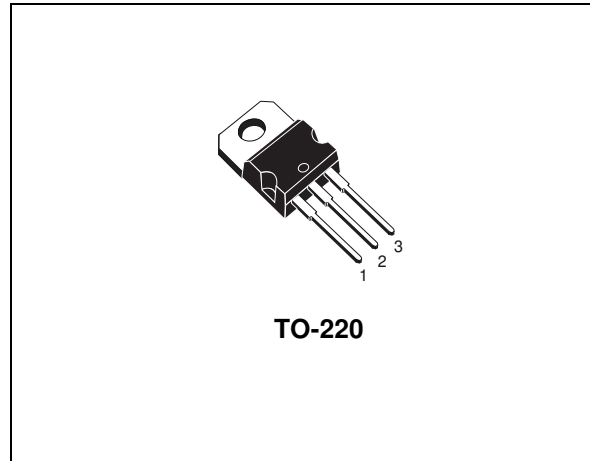

### Internal Schematic Diagram

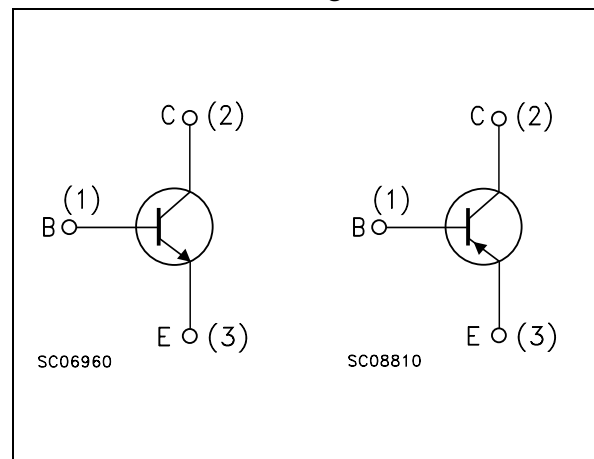

### Order Codes

Part Number	Marking	Package	Packing
TIP41A	TIP41A	TO-220	TUBE
TIP42A	TIP42A	TO-220	TUBE

# 1 Absolute Maximum Ratings

**Table 1. Absolute Maximum Ratings**

Symbol	Parameter	Value	Unit
$V_{CBO}$	Collector-Base Voltage ( $I_E = 0$ )	60	V
$V_{CEO}$	Collector-Emitter Voltage ( $I_B = 0$ )	60	V
$V_{EBO}$	Emitter-Base Voltage ( $I_C = 0$ )	5	V
$I_C$	Collector Current	6	A
$I_{CM}$	Collector Peak Current	10	A
$I_B$	Base Current	3	mA
$P_{TOT}$	Total dissipation at $T_{case} = 25^\circ\text{C}$	65	W
	$T_{amb} = 25^\circ\text{C}$	2	W
$T_{stg}$	Storage Temperature	-65 to 150	$^\circ\text{C}$
$T_J$	Max. Operating Junction Temperature	150	$^\circ\text{C}$

Note: For PNP types voltage and current values are negative

## 2 Electrical Characteristics

$T_{\text{case}} = 25^{\circ}\text{C}$ ; unless otherwise specified

**Table 2. Electrical Characteristics**

Symbol	Parameter	Test Conditions	Min.	Typ.	Max.	Unit
$I_{\text{CEO}}$	Collector Cut-off Current ( $I_{\text{B}} = 0$ )	$V_{\text{CE}} = 30\text{ V}$			0.7	mA
$I_{\text{EBO}}$	Emitter Cut-off Current ( $I_{\text{C}} = 0$ )	$V_{\text{EB}} = 5\text{ V}$			1	mA
$I_{\text{CES}}$	Collector Cut-off Current ( $V_{\text{BE}} = 0$ )	$V_{\text{CE}} = 60\text{ V}$			0.4	mA
$V_{\text{CEO(sus)}}$ <i>Note: 1</i>	Collector-Emitter Sustaining Voltage ( $I_{\text{B}} = 0$ )	$I_{\text{C}} = 30\text{ mA}$	60			V
$V_{\text{CE(sat)}}$ <i>Note: 1</i>	Collector-Emitter saturation Voltage	$I_{\text{C}} = 6\text{ A}$ $I_{\text{B}} = 0.6\text{ A}$			1.5	V
$V_{\text{BE(on)}}$ <i>Note: 1</i>	Base-Emitter Voltage	$I_{\text{C}} = 6\text{ A}$ $V_{\text{CE}} = 4\text{ V}$			2	V
$h_{\text{FE}}$ <i>Note: 1</i>	DC Current Gain	$I_{\text{C}} = 0.3\text{ A}$ $V_{\text{CE}} = 4\text{ V}$ $I_{\text{C}} = 3\text{ A}$ $V_{\text{CE}} = 4\text{ V}$	30 15		75	
$h_{\text{fe}}$	Small Signal Current Gain	$I_{\text{C}} = 0.5\text{ A}$ $V_{\text{CE}} = 10\text{ V}$ $f = 1\text{ KHz}$ $I_{\text{C}} = 0.5\text{ A}$ $V_{\text{CE}} = 10\text{ V}$ $f = 1\text{ KHz}$	20 3			

*Note: 1 Pulsed duration = 300  $\mu\text{s}$ , duty cycle  $\leq 1.5\%$ .*

For PNP types voltage e current values are negative.

## 2.1 Typical Characteristic

Figure 1. DC Current Gain (NPN)

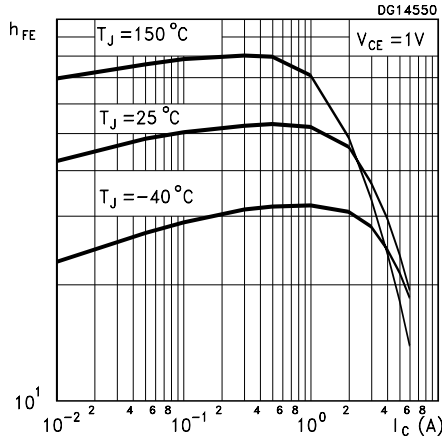

Figure 2. DC Current Gain (PNP)

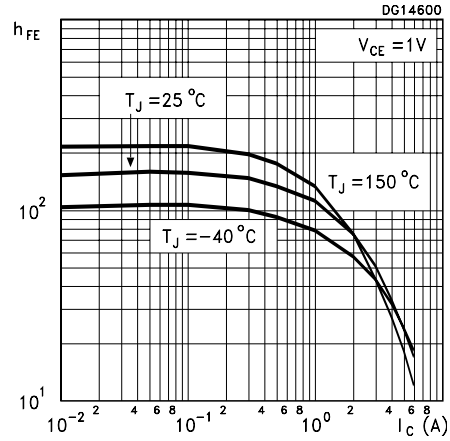

Figure 3. DC Current Gain (NPN)

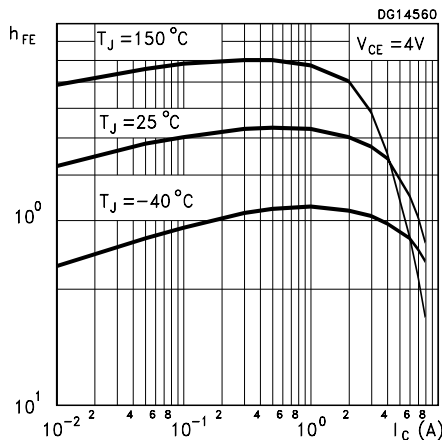

Figure 4. DC Current Gain (PNP)

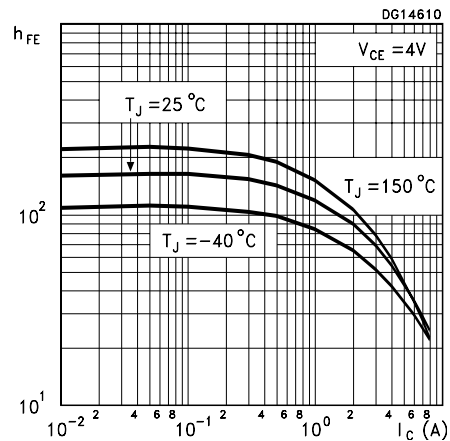

Figure 5. Collector-Emitter Saturation Voltage (NPN)

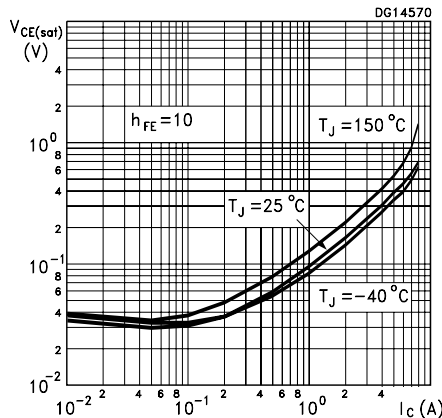

Figure 6. Collector-Emitter Saturation Voltage (PNP)

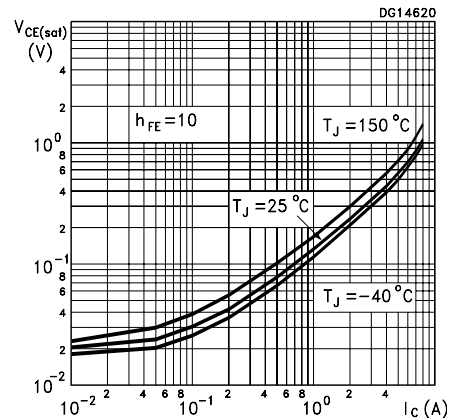

Figure 7. Base-Emitter Saturation Voltage (NPN)

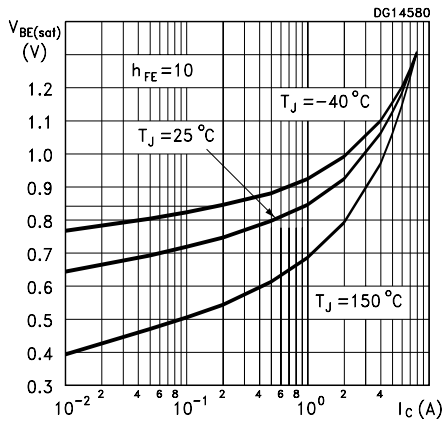

Figure 8. Base-Emitter Saturation Voltage (PNP)

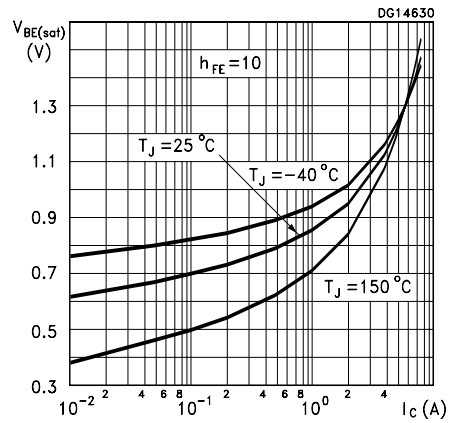

Figure 9.  $BT_{(ON)}$  Time (NPN)

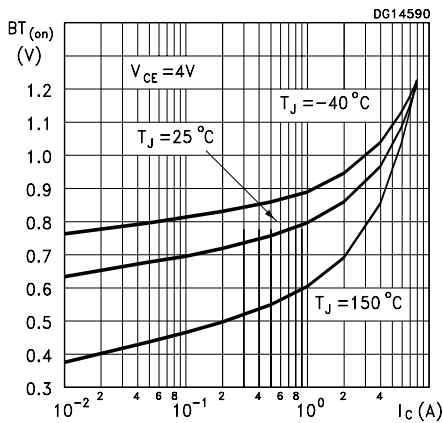

Figure 10.  $BT_{(ON)}$  Time (PNP)

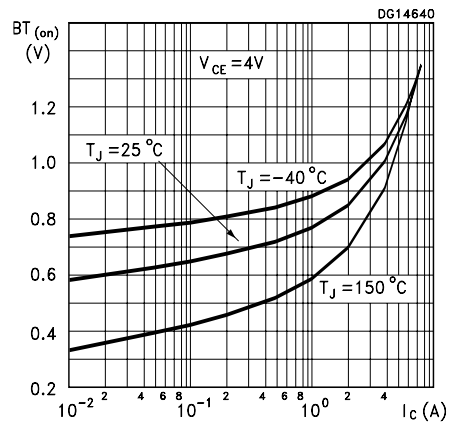

Figure 11. Resistive Load Switching Time (NPN)

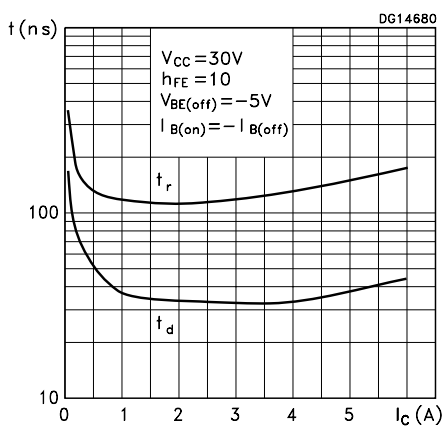
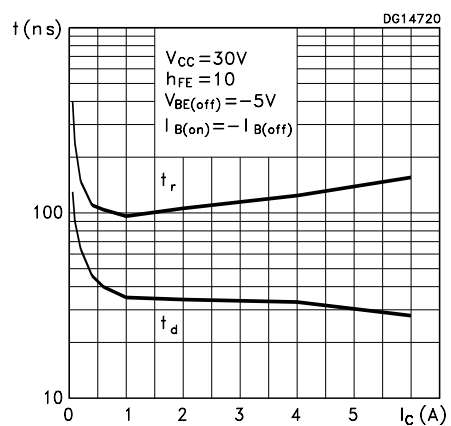
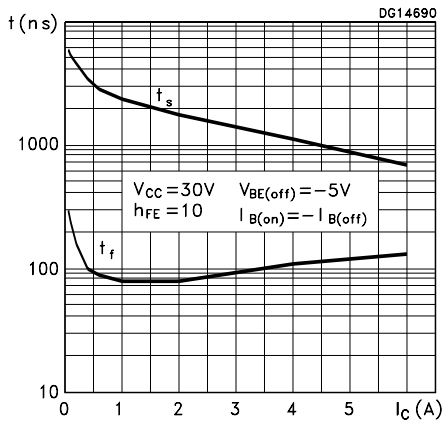

Figure 12. Resistive Load Switching Time (PNP)



**Figure 13. Resistive Load Switching Time (NPN)**



**Figure 14. Resistive Load Switching Time (PNP)**

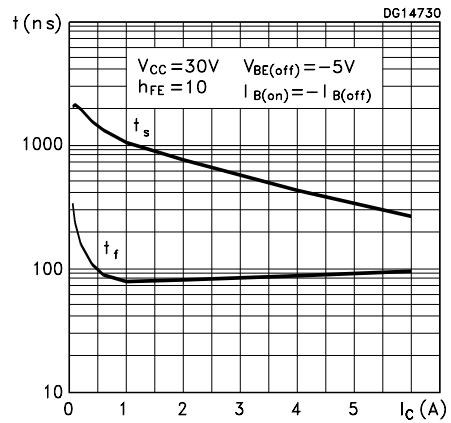

**Figure 15. Collector-Base and Collector-Emitter Capacitance (NPN)**

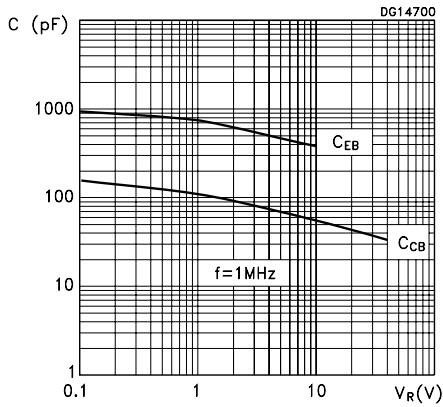

**Figure 16. Collector-Base and Collector-Emitter Capacitance (PNP)**

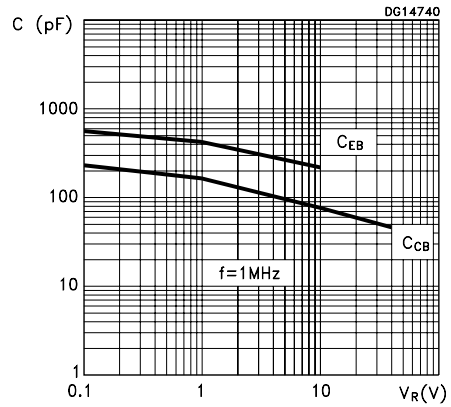

### 3 Package Mechanical Data

In order to meet environmental requirements, ST offers these devices in ECOPACK® packages. These packages have a Lead-free second level interconnect . The category of second level interconnect is marked on the package and on the inner box label, in compliance with JEDEC Standard JESD97. The maximum ratings related to soldering conditions are also marked on the inner box label. ECOPACK is an ST trademark. ECOPACK specifications are available at: [www.st.com](http://www.st.com)



**TO-220 MECHANICAL DATA**

DIM.	mm.			inch		
	MIN.	TYP	MAX.	MIN.	TYP.	MAX.
A	4.40		4.60	0.173		0.181
b	0.61		0.88	0.024		0.034
b1	1.15		1.70	0.045		0.066
c	0.49		0.70	0.019		0.027
D	15.25		15.75	0.60		0.620
E	10		10.40	0.393		0.409
e	2.40		2.70	0.094		0.106
e1	4.95		5.15	0.194		0.202
F	1.23		1.32	0.048		0.052
H1	6.20		6.60	0.244		0.256
J1	2.40		2.72	0.094		0.107
L	13		14	0.511		0.551
L1	3.50		3.93	0.137		0.154
L20		16.40			0.645	
L30		28.90			1.137	
øP	3.75		3.85	0.147		0.151
Q	2.65		2.95	0.104		0.116

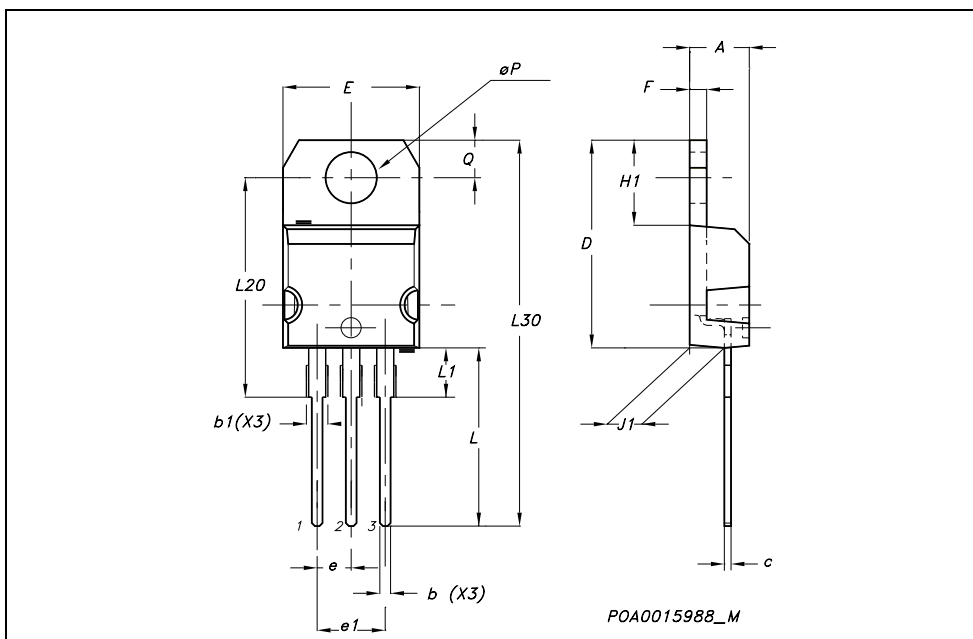

## 4 Revision History

Date	Revision	Changes
27-Oct-2005	1	Initial Release

Information furnished is believed to be accurate and reliable. However, STMicroelectronics assumes no responsibility for the consequences of use of such information nor for any infringement of patents or other rights of third parties which may result from its use. No license is granted by implication or otherwise under any patent or patent rights of STMicroelectronics. Specifications mentioned in this publication are subject to change without notice. This publication supersedes and replaces all information previously supplied. STMicroelectronics products are not authorized for use as critical components in life support devices or systems without express written approval of STMicroelectronics.

The ST logo is a registered trademark of STMicroelectronics.  
All other names are the property of their respective owners

© 2005 STMicroelectronics - All rights reserved

STMicroelectronics group of companies

Australia - Belgium - Brazil - Canada - China - Czech Republic - Finland - France - Germany - Hong Kong - India - Israel - Italy - Japan -  
Malaysia - Malta - Morocco - Singapore - Spain - Sweden - Switzerland - United Kingdom - United States of America

[www.st.com](http://www.st.com)