



Chipsmall Limited consists of a professional team with an average of over 10 year of expertise in the distribution of electronic components. Based in Hongkong, we have already established firm and mutual-benefit business relationships with customers from,Europe,America and south Asia,supplying obsolete and hard-to-find components to meet their specific needs.

With the principle of “Quality Parts,Customers Priority,Honest Operation,and Considerate Service”,our business mainly focus on the distribution of electronic components. Line cards we deal with include Microchip,ALPS,ROHM,Xilinx,Pulse,ON,Everlight and Freescale. Main products comprise IC,Modules,Potentiometer,IC Socket,Relay,Connector.Our parts cover such applications as commercial,industrial, and automotives areas.

We are looking forward to setting up business relationship with you and hope to provide you with the best service and solution. Let us make a better world for our industry!



Contact us

Tel: +86-755-8981 8866 Fax: +86-755-8427 6832

Email & Skype: info@chipsmall.com Web: www.chipsmall.com

Address: A1208, Overseas Decoration Building, #122 Zhenhua RD., Futian, Shenzhen, China



TJF1051

High-speed CAN transceiver

Rev. 5 — 13 July 2016

Product data sheet

1. General description

The TJF1051 is a high-speed CAN transceiver that provides an interface between a Controller Area Network (CAN) protocol controller and the physical two-wire CAN bus. The transceiver is designed for high-speed CAN industrial applications, providing differential transmit and receive capability to (a microcontroller with) a CAN protocol controller.

The TJF1051 belongs to the third generation of high-speed CAN transceivers from NXP Semiconductors, offering significant improvements over first- and second-generation devices such as the TJA1050. It offers improved ElectroMagnetic Compatibility (EMC) and ElectroStatic Discharge (ESD) performance, and also features ideal passive behavior to the CAN bus when the supply voltage is off. The TJF1051T/3 can be interfaced directly to microcontrollers with supply voltages from 3 V to 5 V.

The TJF1051 implements the CAN physical layer as defined in the current ISO11898 standard (ISO11898-2:2003, ISO11898-5:2007) and the pending updated version of ISO 11898-2:2016. Pending the release of the updated version of ISO11898-2:2016 including CAN FD and SAE J2284-4/5, additional timing parameters defining loop delay symmetry are specified. This implementation enables reliable communication in the CAN FD fast phase at data rates up to 5 Mbit/s.

These features make the TJF1051 an excellent choice for all types of HS-CAN networks, in nodes that do not require a standby mode with wake-up capability via the bus.

2. Features and benefits

2.1 General

- Fully ISO 11898-2:2003 compliant
- Timing guaranteed for data rates up to 5 Mbit/s in the CAN FD fast phase
- Low ElectroMagnetic Emission (EME) and high ElectroMagnetic Immunity (EMI)
- V_{IO} input on the TJF1051T/3 allows for direct interfacing with 3 V to 5 V microcontrollers
- Dark green product (halogen free and Restriction of Hazardous Substances (RoHS) compliant)

2.2 Low-power management

- Functional behavior predictable under all supply conditions
- Transceiver disengages from the bus when not powered up (zero load)



2.3 Protection

- High ESD handling capability on the bus pins
- Transmit Data (TXD) dominant time-out function
- Undervoltage detection on pins V_{CC} and V_{IO}
- Thermally protected

3. Quick reference data

Table 1. Quick reference data

Symbol	Parameter	Conditions	Min	Typ	Max	Unit
V_{CC}	supply voltage		4.5	-	5.5	V
V_{IO}	supply voltage on pin V_{IO}		2.8	-	5.5	V
$V_{uvd}(V_{CC})$	undervoltage detection voltage on pin V_{CC}		3.5	-	4.5	V
$V_{uvd}(V_{IO})$	undervoltage detection voltage on pin V_{IO}		1.3	2.0	2.7	V
I_{CC}	supply current	Silent mode	0.1	1	2.5	mA
		Normal mode; bus recessive	2.5	5	10	mA
		Normal mode; bus dominant	20	50	70	mA
I_{IO}	supply current on pin V_{IO}	Normal and Silent modes				
		recessive; $V_{TXD} = V_{IO}$	10	80	250	μ A
		dominant; $V_{TXD} = 0$ V	50	350	500	μ A
V_{ESD}	electrostatic discharge voltage	HBM on pins CANH and CANL	-8	-	+8	kV
V_{CANH}	voltage on pin CANH		-58	-	+58	V
V_{CANL}	voltage on pin CANL		-58	-	+58	V

4. Ordering information

Table 2. Ordering information

Type number	Package		Version
	Name	Description	
TJF1051T	SO8	plastic small outline package; 8 leads; body width 3.9 mm	SOT96-1
TJF1051T/3 ^[1]	SO8	plastic small outline package; 8 leads; body width 3.9 mm	SOT96-1

[1] TJF1051T/3 with V_{IO} pin.

6. Pinning information

6.1 Pinning

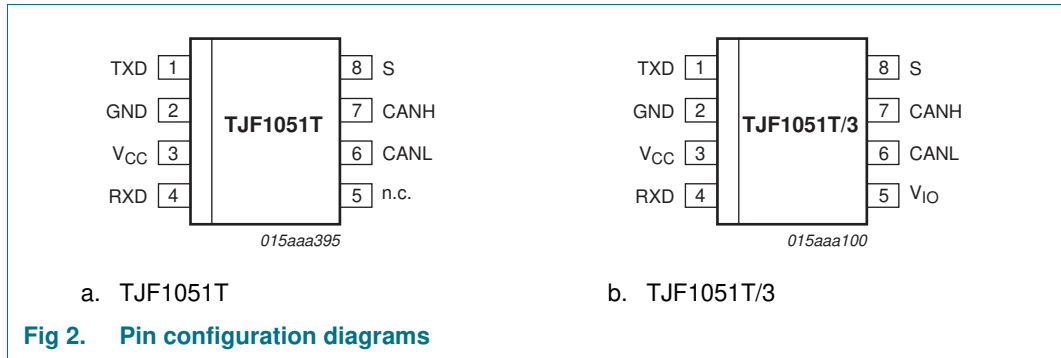

6.2 Pin description

Table 3. Pin description

Symbol	Pin	Description
TXD	1	transmit data input
GND	2	ground
V _{CC}	3	supply voltage
RXD	4	receive data output; reads out data from the bus lines
n.c.	5	not connected; in TJF1051T
V _{IO}	5	supply voltage for I/O level adapter; TJF1051T/3 only
CANL	6	LOW-level CAN bus line
CANH	7	HIGH-level CAN bus line
S	8	Silent mode control input

7. Functional description

The TJF1051 is a stand-alone high-speed CAN transceiver with Silent mode. It combines the functionality of the TJA1050 transceiver with improved EMC and ESD handling capability. Improved slope control and high DC handling capability on the bus pins provides additional application flexibility. The TJF1051T/3 allows for direct interfacing to microcontrollers with supply voltages down to 3 V.

7.1 Operating modes

The TJF1051 supports two operating modes, Normal and Silent. The operating mode is selected via pin S. See [Table 4](#) for a description of the operating modes under normal supply conditions.

Table 4. Operating modes

Mode	Inputs		Outputs	
	Pin S	Pin TXD	CAN driver	Pin RXD
Normal	LOW	LOW	dominant	active ^[1]
	LOW	HIGH	recessive	active ^[1]
Silent	HIGH	X ^[2]	recessive	active ^[1]

[1] LOW if the CAN bus is dominant, HIGH if the CAN bus is recessive.

[2] X = don't care.

7.1.1 Normal mode

A LOW level on pin S selects Normal mode. In this mode, the transceiver is able to transmit and receive data via bus lines CANH and CANL (see [Figure 1](#) for the block diagram). The differential receiver converts the analog data on the bus lines into digital data which is output to pin RXD. The slopes of the output signals on the bus lines are controlled internally and are optimized in a way that guarantees the lowest possible EME levels.

7.1.2 Silent mode

A HIGH level on pin S selects Silent mode. In Silent mode the transmitter is disabled, releasing the bus pins to recessive state. All other IC functions, including the receiver, continue to operate as in Normal mode. Silent mode can be used to prevent a faulty CAN controller from disrupting all network communications.

7.2 Fail-safe features

7.2.1 TXD dominant time-out function

A 'TXD dominant time-out' timer is started when pin TXD is set LOW. If the LOW state on pin TXD persists for longer than $t_{to(dom)TXD}$, the transmitter is disabled, releasing the bus lines to recessive state. This function prevents a hardware and/or software application failure from driving the bus lines to a permanent dominant state (blocking all network communications). The TXD dominant time-out timer is reset when pin TXD is set HIGH. The TXD dominant time-out time also defines the minimum possible bit rate of 20 kbit/s.

7.2.2 Internal biasing of TXD and S input pins

Pin TXD has an internal pull-up to V_{IO} and pin S has an internal pull-down to GND. This ensures a safe, defined state in case one (or both) of these pins is left floating.

7.2.3 Undervoltage detection on pins V_{CC} and V_{IO}

Should V_{CC} or V_{IO} drop below their respective undervoltage detection levels ($V_{uvd(VCC)}$ and $V_{uvd(VIO)}$); see [Table 7](#), the transceiver will switch off and disengage from the bus (zero load) until V_{CC} and V_{IO} have recovered.

7.2.4 Overtemperature protection

The output drivers are protected against overtemperature conditions. If the virtual junction temperature exceeds the shutdown junction temperature, $T_{j(sd)}$, the output drivers will be disabled until the virtual junction temperature falls below $T_{j(sd)}$ and TXD becomes recessive again. Including the TXD condition ensures that output driver oscillations due to temperature drift are avoided.

7.3 V_{IO} supply pin (TJF1051T/3)

Pin V_{IO} on the TJF1051T/3 should be connected to the microcontroller supply voltage (see [Figure 5](#)). This adjusts the signal levels on pins TXD, RXD and S to the I/O levels of the microcontroller. In the TJF1051T, the V_{IO} input is internally connected to V_{CC} . This sets the signal levels of pins TXD, RXD and S to levels compatible with 5 V microcontrollers.

8. Limiting values

Table 5. Limiting values

In accordance with the Absolute Maximum Rating System (IEC 60134). All voltages are referenced to GND.

Symbol	Parameter	Conditions	Min	Max	Unit
V_x	voltage on pin x ^[1]	on pins CANH, CANL	-58	+58	V
		on any other pin	-0.3	+7	V
$V_{(CANH-CANL)}$	voltage between pin CANH and pin CANL		-27	+27	V
V_{ESD}	electrostatic discharge voltage	Human Body Model (HBM); 100 pF, 1.5 k Ω	^[2]		
		pins CANH and CANL	-8	+8	kV
		any other pin	-4	+4	kV
		Machine Model (MM); 200 pF, 0.75 μ H, 10 Ω	^[3]		
	any pin		-300	+300	V
T_{vj}	virtual junction temperature		^[4] -40	+125	$^{\circ}$ C
T_{stg}	storage temperature		-55	+150	$^{\circ}$ C

- [1] The device can sustain voltages up to the specified values over the product lifetime, provided applied voltages (including transients) never exceed these values.
- [2] According to AEC-Q100-002.
- [3] According to AEC-Q100-003.
- [4] In accordance with IEC 60747-1. An alternative definition of virtual junction temperature is: $T_{vj} = T_{amb} + P \times R_{th(vj-a)}$, where $R_{th(vj-a)}$ is a fixed value to be used for the calculation of T_{vj} . The rating for T_{vj} limits the allowable combinations of power dissipation (P) and ambient temperature (T_{amb}).

9. Thermal characteristics

Table 6. Thermal characteristics

According to IEC 60747-1.

Symbol	Parameter	Conditions	Value	Unit
$R_{th(vj-a)}$	thermal resistance from virtual junction to ambient	in free air	120	K/W

10. Static characteristics

Table 7. Static characteristics

$T_{amb} = -40\text{ }^{\circ}\text{C}$ to $+105\text{ }^{\circ}\text{C}$; $V_{CC} = 4.5\text{ V}$ to 5.5 V ; $V_{IO} = 2.8\text{ V}$ to 5.5 V ^[2]; $R_L = 60\text{ }\Omega$; unless otherwise specified; all voltages are defined with respect to ground; positive currents flow into the device^[1].

Symbol	Parameter	Conditions	Min	Typ	Max	Unit
Supply; pin V_{CC}						
V_{CC}	supply voltage		4.5	-	5.5	V
I_{CC}	supply current	Silent mode	0.1	1	2.5	mA
		Normal mode				
		recessive	2.5	5	10	mA
		dominant; $V_{TXD} = 0\text{ V}$	20	50	70	mA
$V_{uvd(VCC)}$	undervoltage detection voltage on pin V_{CC}		3.5	-	4.5	V
I/O level adapter supply; pin V_{IO}^[2]						
V_{IO}	supply voltage on pin V_{IO}		2.8	-	5.5	V
I_{IO}	supply current on pin V_{IO}	Normal and Silent modes				
		recessive; $V_{TXD} = V_{IO}$ ^[3]	10	80	250	μA
		dominant; $V_{TXD} = 0\text{ V}$	50	350	500	μA
$V_{uvd(VIO)}$	undervoltage detection voltage on pin V_{IO}		1.3	2.0	2.7	V
Mode control input; pin S						
V_{IH}	HIGH-level input voltage		^[4] $0.7V_{IO}$ ^[3]	-	$V_{IO} + 0.3$ ^[3]	V
V_{IL}	LOW-level input voltage		-0.3	-	$+0.3V_{IO}$ ^[3]	V
I_{IH}	HIGH-level input current		1	4	10	μA
I_{IL}	LOW-level input current	$V_S = 0\text{ V}$	-1	0	+1	μA
CAN transmit data input; pin TXD						
V_{IH}	HIGH-level input voltage		^[4] $0.7V_{IO}$ ^[3]	-	$V_{IO} + 0.3$ ^[3]	V
V_{IL}	LOW-level input voltage		-0.3	-	$+0.3V_{IO}$ ^[3]	V
I_{IH}	HIGH-level input current	$V_{TXD} = V_{IO}$ ^[3]	-5	0	+5	μA
I_{IL}	LOW-level input current	Normal mode; $V_{TXD} = 0\text{ V}$	-260	-150	-30	μA
C_i	input capacitance		-	5	10	pF
CAN receive data output; pin RXD						
I_{OH}	HIGH-level output current	$V_{RXD} = V_{IO} - 0.4\text{ V}$ ^[3]	-8	-3	-1	mA
I_{OL}	LOW-level output current	$V_{RXD} = 0.4\text{ V}$; bus dominant	2	5	12	mA

Table 7. Static characteristics ...continued

$T_{amb} = -40\text{ }^{\circ}\text{C}$ to $+105\text{ }^{\circ}\text{C}$; $V_{CC} = 4.5\text{ V}$ to 5.5 V ; $V_{IO} = 2.8\text{ V}$ to 5.5 V [2]; $R_L = 60\text{ }\Omega$; unless otherwise specified; all voltages are defined with respect to ground; positive currents flow into the device[1].

Symbol	Parameter	Conditions	Min	Typ	Max	Unit
Bus lines; pins CANH and CANL						
$V_{O(dom)}$	dominant output voltage	$V_{TXD} = 0\text{ V}$; $t < t_{to(dom)TXD}$				
		pin CANH; $R_L = 50\text{ }\Omega$ to $65\text{ }\Omega$	2.75	3.5	4.5	V
		pin CANL; $R_L = 50\text{ }\Omega$ to $65\text{ }\Omega$	0.5	1.5	2.25	V
$V_{dom(TX)sym}$	transmitter dominant voltage symmetry	$V_{dom(TX)sym} = V_{CC} - V_{CANH} - V_{CANL}$	-400	0	+400	mV
V_{TXsym}	transmitter voltage symmetry	$V_{TXsym} = V_{CANH} + V_{CANL}$; $f_{TXD} = 250\text{ kHz}$; $C_{SPLIT} = 4.7\text{ nF}$	[5] [6] 0.9 V_{CC}	-	1.1 V_{CC}	V
$V_{O(dif)}$	differential output voltage	dominant; Normal mode				
		$V_{TXD} = 0\text{ V}$; $t < t_{to(dom)TXD}$; $V_{CC} = 4.75\text{ V}$ to 5.25 V ; $R_L = 50\text{ }\Omega$ to $65\text{ }\Omega$	1.5	-	3	V
		$V_{TXD} = 0\text{ V}$; $t < t_{to(dom)TXD}$; $V_{CC} = 4.75\text{ V}$ to 5.25 V ; $R_L = 45\text{ }\Omega$ to $70\text{ }\Omega$	1.4	-	3.3	V
		$V_{TXD} = 0\text{ V}$; $t < t_{to(dom)TXD}$; $V_{CC} = 4.75\text{ V}$ to 5.25 V ; $R_L = 2240\text{ }\Omega$	1.5	-	5	V
		recessive				
		Normal mode: $V_{TXD} = V_{IO}$ [3]; no load	-50	-	+50	mV
$V_{O(rec)}$	recessive output voltage	Normal and Silent modes; $V_{TXD} = V_{IO}$ [3]; no load	2	0.5 V_{CC}	3	V
$V_{th(RX)dif}$	differential receiver threshold voltage	Normal and Silent modes $-12\text{ V} \leq V_{CANL} \leq +12\text{ V}$; $-12\text{ V} \leq V_{CANH} \leq +12\text{ V}$	0.5	0.7	0.9	V
$V_{rec(RX)}$	receiver recessive voltage	Normal/Silent mode; $-12\text{ V} \leq V_{CANL} \leq +12\text{ V}$; $-12\text{ V} \leq V_{CANH} \leq +12\text{ V}$	-3	-	+0.5	V
$V_{dom(RX)}$	receiver dominant voltage	Normal/Silent mode; $-12\text{ V} \leq V_{CANL} \leq +12\text{ V}$; $-12\text{ V} \leq V_{CANH} \leq +12\text{ V}$	0.9	-	8.0	V
$V_{hys(RX)dif}$	differential receiver hysteresis voltage	Normal and Silent modes $-12\text{ V} \leq V_{CANL} \leq +12\text{ V}$; $-12\text{ V} \leq V_{CANH} \leq +12\text{ V}$	50	120	400	mV
$I_{O(sc)dom}$	dominant short-circuit output current	$V_{TXD} = 0\text{ V}$; $t < t_{to(dom)TXD}$; $V_{CC} = 5\text{ V}$				
		pin CANH; $V_{CANH} = -3\text{ V}$ to $+40\text{ V}$	-120	-70	-40	mA
		pin CANL; $V_{CANL} = -3\text{ V}$ to $+40\text{ V}$	40	70	120	mA
$I_{O(sc)rec}$	recessive short-circuit output current	Normal and Silent modes; $V_{TXD} = V_{CC}$; $V_{CANH} = V_{CANL} = -27\text{ V}$ to $+32\text{ V}$	-5	-	+5	mA
I_L	leakage current	$V_{CC} = V_{IO} = 0\text{ V}$ or $V_{CC} = V_{IO} =$ shorted to ground via $47\text{ k}\Omega$; $V_{CANH} = V_{CANL} = 5\text{ V}$	-5	0	+5	μA
R_i	input resistance		9	15	28	$\text{k}\Omega$

Table 7. Static characteristics ...continued

$T_{amb} = -40\text{ }^{\circ}\text{C}$ to $+105\text{ }^{\circ}\text{C}$; $V_{CC} = 4.5\text{ V}$ to 5.5 V ; $V_{IO} = 2.8\text{ V}$ to 5.5 V ^[2]; $R_L = 60\ \Omega$; unless otherwise specified; all voltages are defined with respect to ground; positive currents flow into the device^[1].

Symbol	Parameter	Conditions	Min	Typ	Max	Unit
ΔR_i	input resistance deviation	between V_{CANH} and V_{CANL}	-3	0	+3	%
$R_{i(dif)}$	differential input resistance		19	30	52	$k\Omega$
$C_{i(cm)}$	common-mode input capacitance		-	-	20	pF
$C_{i(dif)}$	differential input capacitance		-	-	10	pF
Temperature protection						
$T_{j(sd)}$	shutdown junction temperature		-	190	-	$^{\circ}\text{C}$

- [1] All parameters are guaranteed over the virtual junction temperature range by design. Factory testing uses correlated test conditions to cover the specified temperature and power supply voltage range.
- [2] Only the TJF1051T/3 has a V_{IO} pin; in the TJF1051T, the V_{IO} input is internally connected to V_{CC} .
- [3] $V_{IO} = V_{CC}$ for the non- V_{IO} product variants TJF1051T
- [4] Maximum value assumes $V_{CC} < V_{IO}$; if $V_{CC} > V_{IO}$, the maximum value will be $V_{CC} + 0.3\text{ V}$.
- [5] Not tested in production; guaranteed by design.
- [6] The test circuit used to measure the bus output voltage symmetry (which includes C_{SPLIT}) is shown in [Figure 7](#).

11. Dynamic characteristics

Table 8. Dynamic characteristics

$T_{vj} = -40\text{ }^{\circ}\text{C}$ to $+150\text{ }^{\circ}\text{C}$; $V_{CC} = 4.5\text{ V}$ to 5.5 V ; $V_{IO} = 2.8\text{ V}$ to 5.5 V ^[1]; $R_L = 60\text{ }\Omega$ unless specified otherwise. All voltages are defined with respect to ground. Positive currents flow into the IC.^[2]

Symbol	Parameter	Conditions	Min	Typ	Max	Unit
Transceiver timing; pins CANH, CANL, TXD and RXD; see Figure 6 and Figure 3						
$t_{d(\text{TXD-busdom})}$	delay time from TXD to bus dominant	Normal mode	-	65	-	ns
$t_{d(\text{TXD-busrec})}$	delay time from TXD to bus recessive	Normal mode	-	90	-	ns
$t_{d(\text{busdom-RXD})}$	delay time from bus dominant to RXD	Normal and Silent modes	-	60	-	ns
$t_{d(\text{busrec-RXD})}$	delay time from bus recessive to RXD	Normal and Silent modes	-	65	-	ns
$t_{d(\text{TXDL-RXDL})}$	delay time from TXD LOW to RXD LOW	Normal mode: versions with V_{IO} pin	40	-	250	ns
		Normal mode: other versions	40	-	220	ns
$t_{d(\text{TXDH-RXDH})}$	delay time from TXD HIGH to RXD HIGH	Normal mode: versions with V_{IO} pin	40	-	250	ns
		Normal mode: other versions	40	-	220	ns
$t_{\text{bit}(\text{bus})}$	transmitted recessive bit width	$t_{\text{bit}(\text{TXD})} = 500\text{ ns}$ ^[3]	435	-	530	ns
		$t_{\text{bit}(\text{TXD})} = 200\text{ ns}$ ^[3]	155	-	210	ns
$t_{\text{bit}(\text{RXD})}$	bit time on pin RXD	$t_{\text{bit}(\text{TXD})} = 500\text{ ns}$ ^[3]	400	-	550	ns
		$t_{\text{bit}(\text{TXD})} = 200\text{ ns}$ ^[3]	120	-	220	ns
Δt_{rec}	receiver timing symmetry	$t_{\text{bit}(\text{TXD})} = 500\text{ ns}$	-65	-	+40	ns
		$t_{\text{bit}(\text{TXD})} = 200\text{ ns}$	-45	-	+15	ns
$t_{\text{to}(\text{dom})\text{TXD}}$	TXD dominant time-out time	$V_{\text{TXD}} = 0\text{ V}$; Normal mode	0.3	1	5	ms

[1] Only TJF1051T/3 and TJF1051TK/3 have a V_{IO} pin. In transceivers without a V_{IO} pin, the V_{IO} input is internally connected to V_{CC} .

[2] All parameters are guaranteed over the virtual junction temperature range by design. Factory testing uses correlated test conditions to cover the specified temperature and power supply voltage range.

[3] See Figure 4.

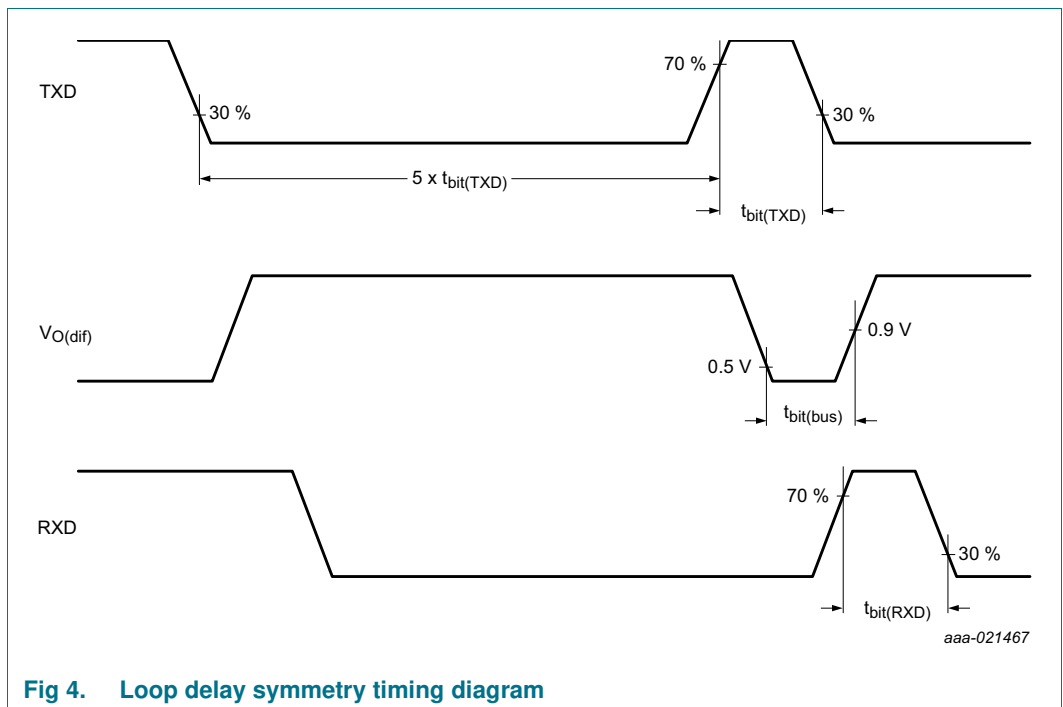
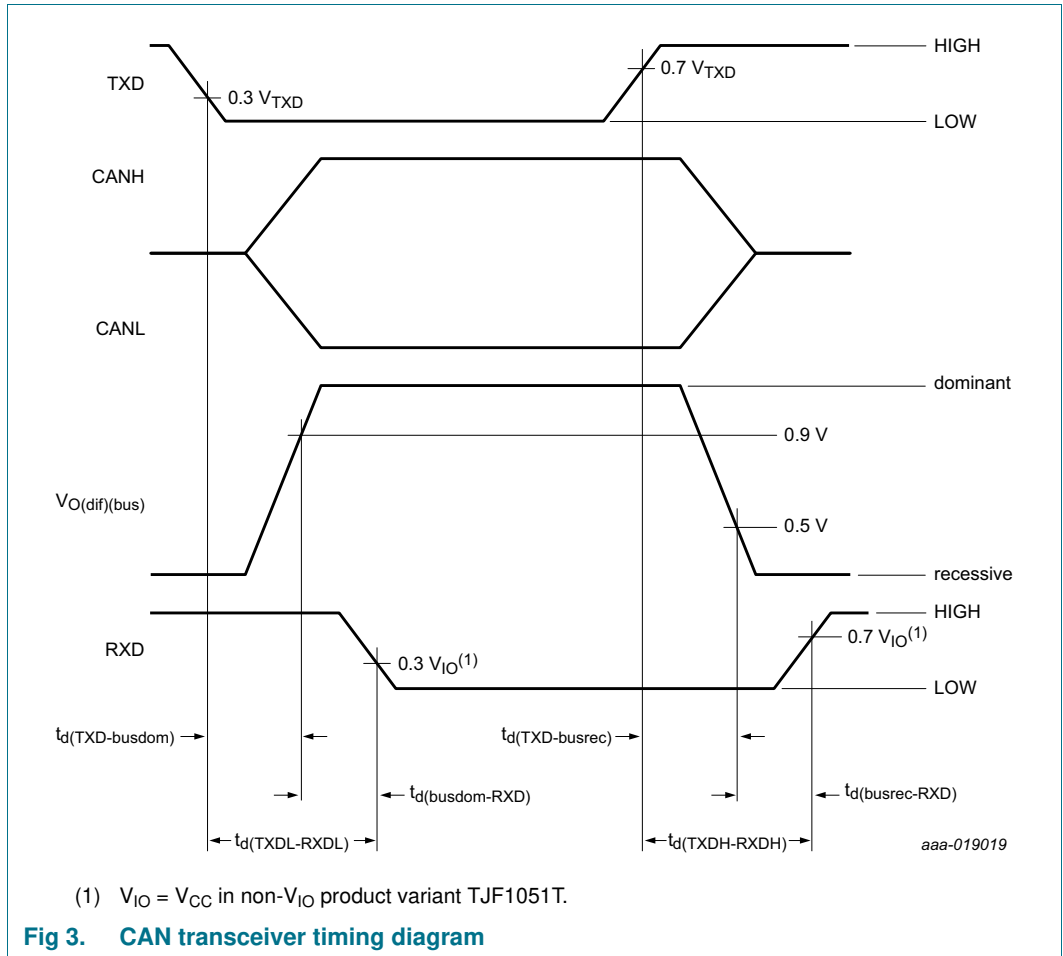

12. Application information

12.1 Application diagram

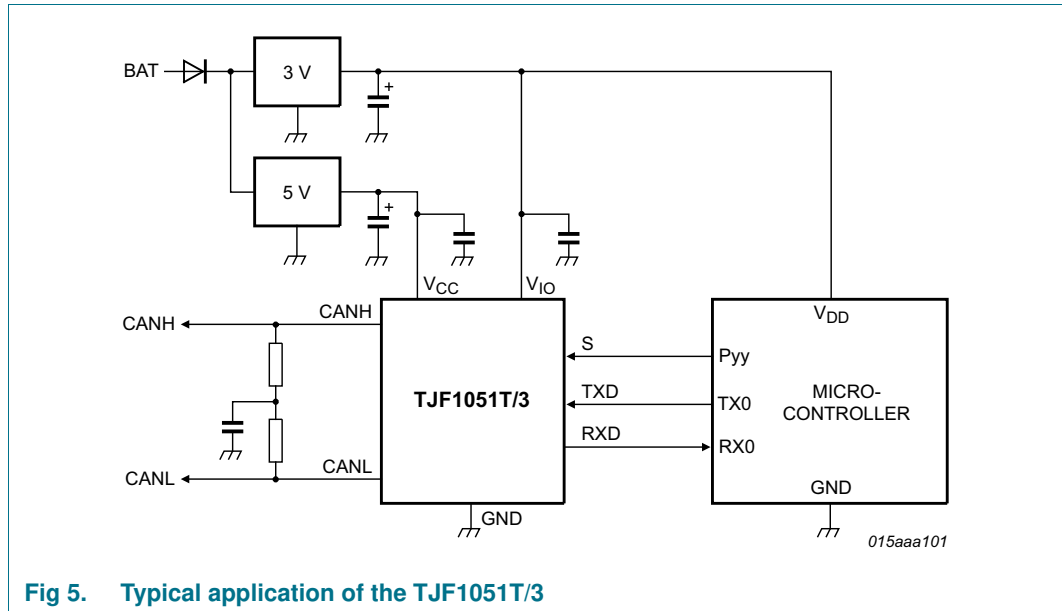
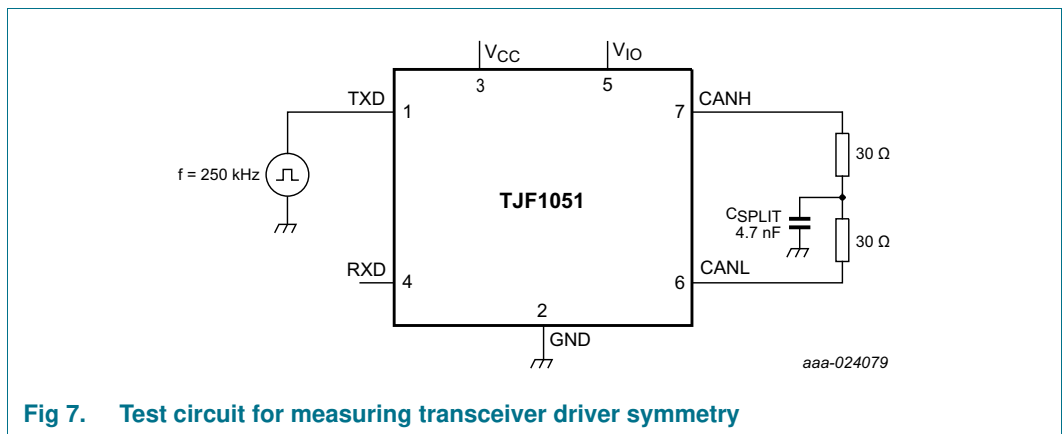
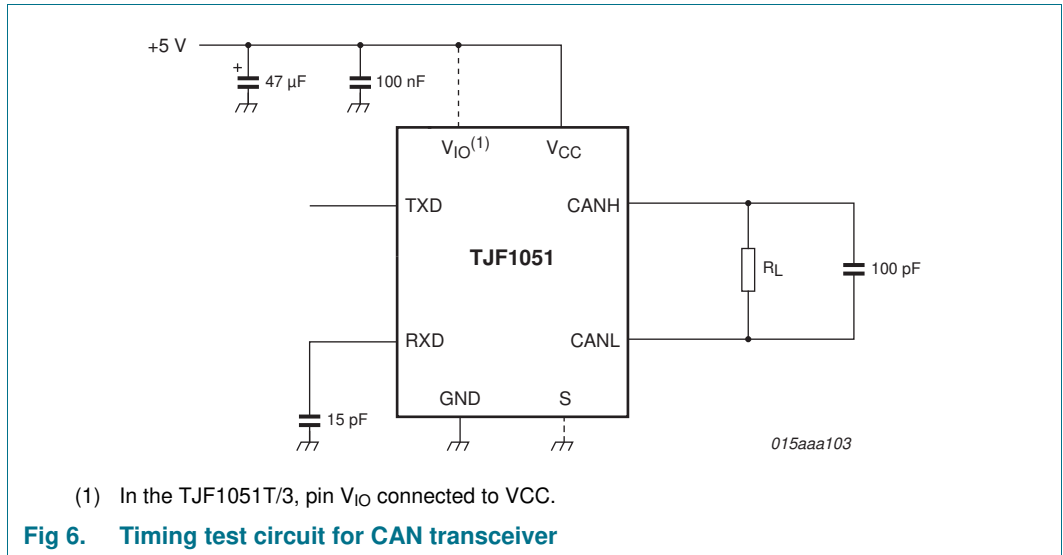

Fig 5. Typical application of the TJF1051T/3

12.2 Application hints

Further information on the application of the TJF1051 can be found in NXP application hints *AH1014 Application Hints - Standalone high speed CAN transceiver TJA1042/TJA1043/TJA1048/TJA1051*.

13. Test information



14. Package outline

SO8: plastic small outline package; 8 leads; body width 3.9 mm

SOT96-1

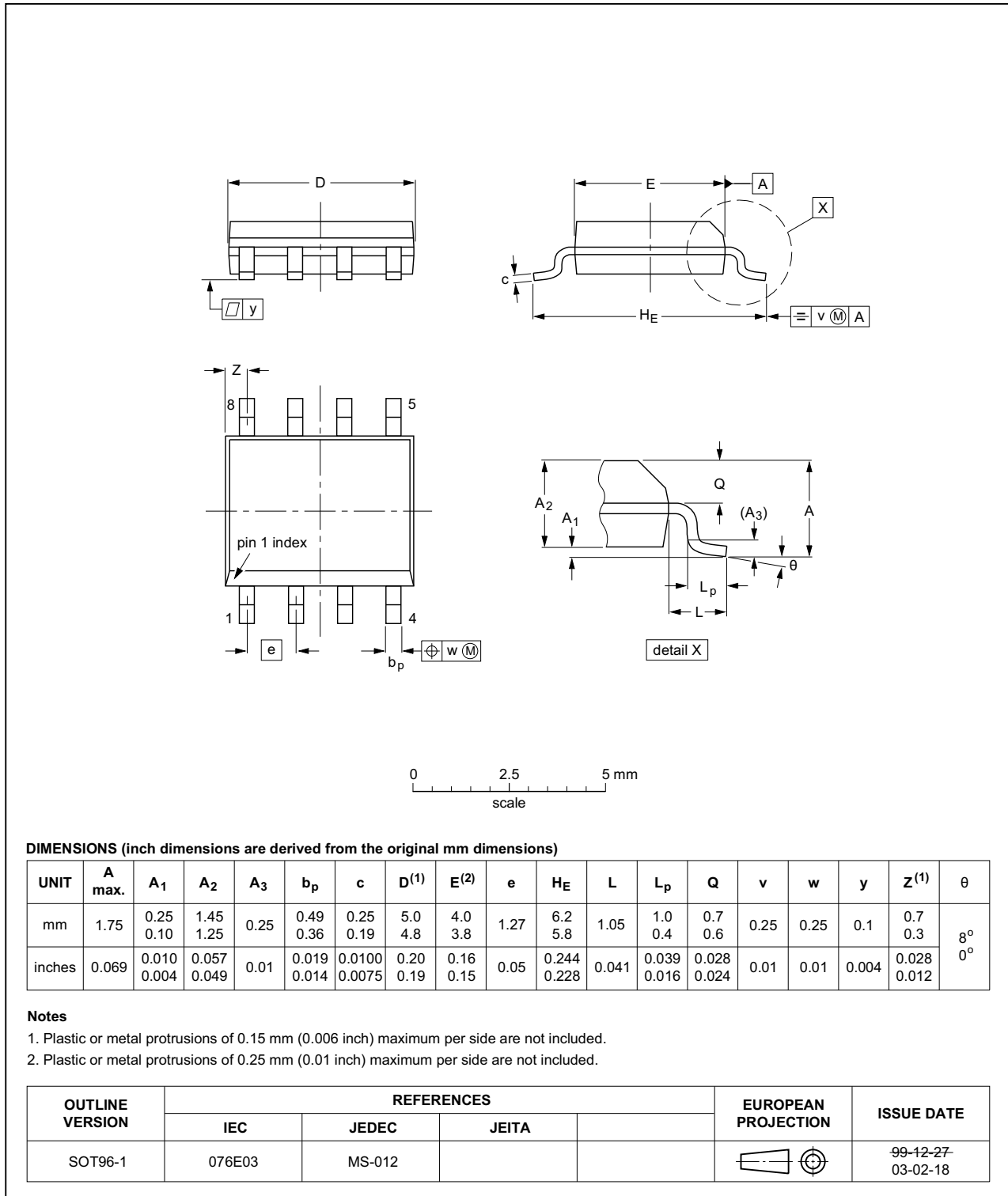

Fig 8. Package outline SOT96-1 (SO8)

15. Handling information

All input and output pins are protected against ElectroStatic Discharge (ESD) under normal handling. When handling ensure that the appropriate precautions are taken as described in *JESD625-A* or equivalent standards.

16. Soldering of SMD packages

This text provides a very brief insight into a complex technology. A more in-depth account of soldering ICs can be found in Application Note *AN10365 "Surface mount reflow soldering description"*.

16.1 Introduction to soldering

Soldering is one of the most common methods through which packages are attached to Printed Circuit Boards (PCBs), to form electrical circuits. The soldered joint provides both the mechanical and the electrical connection. There is no single soldering method that is ideal for all IC packages. Wave soldering is often preferred when through-hole and Surface Mount Devices (SMDs) are mixed on one printed wiring board; however, it is not suitable for fine pitch SMDs. Reflow soldering is ideal for the small pitches and high densities that come with increased miniaturization.

16.2 Wave and reflow soldering

Wave soldering is a joining technology in which the joints are made by solder coming from a standing wave of liquid solder. The wave soldering process is suitable for the following:

- Through-hole components
- Leaded or leadless SMDs, which are glued to the surface of the printed circuit board

Not all SMDs can be wave soldered. Packages with solder balls, and some leadless packages which have solder lands underneath the body, cannot be wave soldered. Also, leaded SMDs with leads having a pitch smaller than ~0.6 mm cannot be wave soldered, due to an increased probability of bridging.

The reflow soldering process involves applying solder paste to a board, followed by component placement and exposure to a temperature profile. Leaded packages, packages with solder balls, and leadless packages are all reflow solderable.

Key characteristics in both wave and reflow soldering are:

- Board specifications, including the board finish, solder masks and vias
- Package footprints, including solder thieves and orientation
- The moisture sensitivity level of the packages
- Package placement
- Inspection and repair
- Lead-free soldering versus SnPb soldering

16.3 Wave soldering

Key characteristics in wave soldering are:

- Process issues, such as application of adhesive and flux, clinching of leads, board transport, the solder wave parameters, and the time during which components are exposed to the wave
- Solder bath specifications, including temperature and impurities

16.4 Reflow soldering

Key characteristics in reflow soldering are:

- Lead-free versus SnPb soldering; note that a lead-free reflow process usually leads to higher minimum peak temperatures (see [Figure 9](#)) than a SnPb process, thus reducing the process window
- Solder paste printing issues including smearing, release, and adjusting the process window for a mix of large and small components on one board
- Reflow temperature profile; this profile includes preheat, reflow (in which the board is heated to the peak temperature) and cooling down. It is imperative that the peak temperature is high enough for the solder to make reliable solder joints (a solder paste characteristic). In addition, the peak temperature must be low enough that the packages and/or boards are not damaged. The peak temperature of the package depends on package thickness and volume and is classified in accordance with [Table 9](#) and [10](#)

Table 9. SnPb eutectic process (from J-STD-020D)

Package thickness (mm)	Package reflow temperature (°C)	
	Volume (mm ³)	
	< 350	≥ 350
< 2.5	235	220
≥ 2.5	220	220

Table 10. Lead-free process (from J-STD-020D)

Package thickness (mm)	Package reflow temperature (°C)		
	Volume (mm ³)		
	< 350	350 to 2000	> 2000
< 1.6	260	260	260
1.6 to 2.5	260	250	245
> 2.5	250	245	245

Moisture sensitivity precautions, as indicated on the packing, must be respected at all times.

Studies have shown that small packages reach higher temperatures during reflow soldering, see [Figure 9](#).

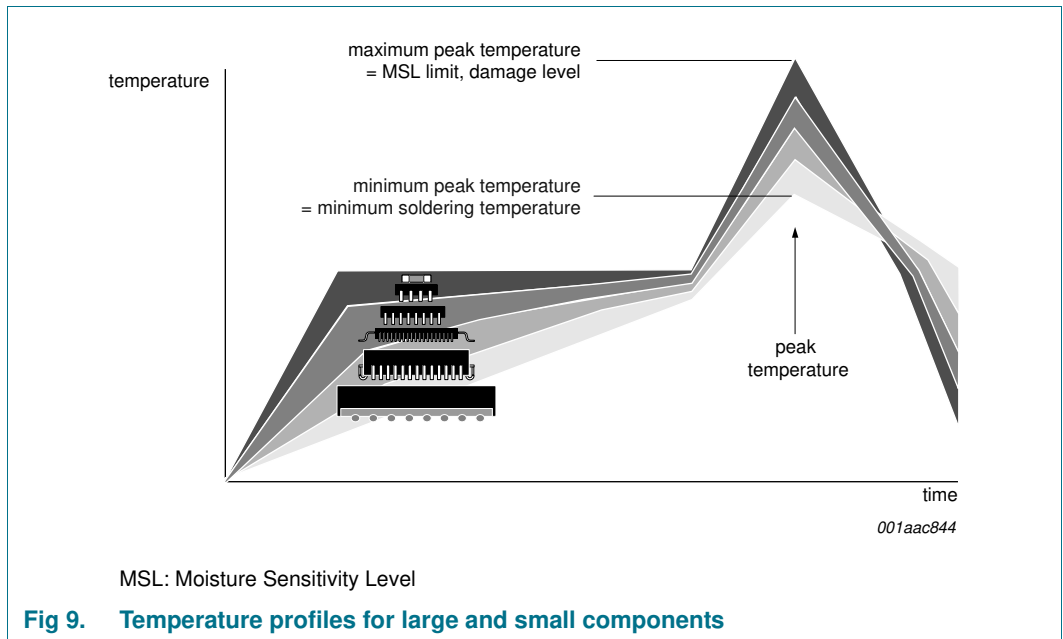

For further information on temperature profiles, refer to Application Note AN10365 “Surface mount reflow soldering description”.

17. Appendix: ISO 11898-2:2016 parameter cross-reference list

Table 11. ISO 11898-2:2016 to NXP data sheet parameter conversion

ISO 11898-2:2016		NXP data sheet	
Parameter	Notation	Symbol	Parameter
HS-PMA dominant output characteristics			
Single ended voltage on CAN_H	V_{CAN_H}	$V_{O(dom)}$	dominant output voltage
Single ended voltage on CAN_L	V_{CAN_L}		
Differential voltage on normal bus load	V_{Diff}	$V_{O(dif)}$	differential output voltage
Differential voltage on effective resistance during arbitration			
Optional: Differential voltage on extended bus load range			
HS-PMA driver symmetry			
Driver symmetry	V_{SYM}	V_{TXsym}	transmitter voltage symmetry
Maximum HS-PMA driver output current			
Absolute current on CAN_H	I_{CAN_H}	$I_{O(sc)dom}$	dominant short-circuit output current
Absolute current on CAN_L	I_{CAN_L}		
HS-PMA recessive output characteristics, bus biasing active/inactive			
Single ended output voltage on CAN_H	V_{CAN_H}	$V_{O(rec)}$	recessive output voltage
Single ended output voltage on CAN_L	V_{CAN_L}		
Differential output voltage	V_{Diff}	$V_{O(dif)}$	differential output voltage
Optional HS-PMA transmit dominant timeout			
Transmit dominant timeout, long	t_{dom}	$t_{to(dom)TXD}$	TXD dominant time-out time
Transmit dominant timeout, short			
HS-PMA static receiver input characteristics, bus biasing active/inactive			
Recessive state differential input voltage range	V_{Diff}	$V_{th(RX)dif}$	differential receiver threshold voltage
Dominant state differential input voltage range		$V_{rec(RX)}$	receiver recessive voltage
		$V_{dom(RX)}$	receiver dominant voltage
HS-PMA receiver input resistance (matching)			
Differential internal resistance	R_{Diff}	$R_{i(dif)}$	differential input resistance
Single ended internal resistance	R_{CAN_H} R_{CAN_L}	R_i	input resistance
Matching of internal resistance	MR	ΔR_i	input resistance deviation
HS-PMA implementation loop delay requirement			
Loop delay	t_{Loop}	$t_{d(TXDH-RXDH)}$	delay time from TXD HIGH to RXD HIGH
		$t_{d(TXDL-RXDL)}$	delay time from TXD LOW to RXD LOW
Optional HS-PMA implementation data signal timing requirements for use with bit rates above 1 Mbit/s up to 2 Mbit/s and above 2 Mbit/s up to 5 Mbit/s			
Transmitted recessive bit width @ 2 Mbit/s / @ 5 Mbit/s, intended	$t_{Bit(Bus)}$	$t_{bit(bus)}$	transmitted recessive bit width
Received recessive bit width @ 2 Mbit/s / @ 5 Mbit/s	$t_{Bit(RXD)}$	$t_{bit(RXD)}$	bit time on pin RXD
Receiver timing symmetry @ 2 Mbit/s / @ 5 Mbit/s	Δt_{Rec}	Δt_{rec}	receiver timing symmetry

Table 11. ISO 11898-2:2016 to NXP data sheet parameter conversion ...continued

ISO 11898-2:2016		NXP data sheet	
Parameter	Notation	Symbol	Parameter
HS-PMA maximum ratings of V_{CAN_H}, V_{CAN_L} and V_{Diff}			
Maximum rating V _{Diff}	V _{Diff}	V _(CANH-CANL)	voltage between pin CANH and pin CANL
General maximum rating V _{CAN_H} and V _{CAN_L}	V _{CAN_H}	V _x	voltage on pin x
Optional: Extended maximum rating V _{CAN_H} and V _{CAN_L}	V _{CAN_L}		
HS-PMA maximum leakage currents on CAN_H and CAN_L, unpowered			
Leakage current on CAN_H, CAN_L	I _{CAN_H} I _{CAN_L}	I _L	leakage current
HS-PMA bus biasing control timings			
CAN activity filter time, long	t _{Filter}	t _{wake(busdom)} ^[1]	bus dominant wake-up time
CAN activity filter time, short		t _{wake(busrec)} ^[1]	bus recessive wake-up time
Wake-up timeout, short	t _{Wake}	t _{to(wake)bus}	bus wake-up time-out time
Wake-up timeout, long			
Timeout for bus inactivity	t _{Silence}	t _{to(silence)}	bus silence time-out time
Bus Bias reaction time	t _{Bias}	t _{d(busact-bias)}	delay time from bus active to bias

[1] t_{fltr(wake)bus} - bus wake-up filter time, in devices with basic wake-up functionality

18. Revision history

Table 12. Revision history

Document ID	Release date	Data sheet status	Change notice	Supersedes
TJF1051 v.5.1	20160713	Product data sheet	-	TJF1051 v.4
Modifications:	<ul style="list-style-type: none"> • Table 5 <ul style="list-style-type: none"> – Table note 1: added for parameter V_x – new parameter added: ($V_{CANH-CANL}$) – text in Conditions column of parameter V_x corrected – parameter V_{trt} reformatted • Section 7.2.1: Last sentence: bit rate changed from 40 kbit/s to 20 kbit/s • Section 12.1: Figure 5 modified • ISO 11898-2:2016 compliance <ul style="list-style-type: none"> – Section 1: text revised (3rd paragraph) – Section 2.1: second list item revised – Table 7: New table note added for the non-V_{IO} product variant TJF1051T (Table note 3) – Table 7: Parameter for $V_{O(dom)}$ modified – Table 7: Parameter V_{TXsym} added – Table 7: Parameter $V_{O(dif)bus}$ changed to $V_{O(dif)}$; Conditions revised – Table 7: Parameter $V_{th(RX)dif}$: Conditions revised; previous Table note 3 deleted – Table 7: Parameter $V_{rec(RX)}$ added – Table 7: Parameter $V_{dom(RX)}$ added – Table 7: Parameter $V_{hys(RX)dif}$: Conditions revised – Table 7: Parameter $I_{O(sc)dom}$: Conditions revised – Table 7: Parameter I_L: Conditions revised – Table 7: previous note 3 deleted – Section 11: Figure 3 and Figure 4 replaced – Table 8: parameters $t_{bit(bus)}$ and Δ_{trec} added – Table 8: parameter $t_{PD(RXD-RXD)}$ replaced by $t_d(TXDL-RXDL)$ and $t_d(TXDH-RXDH)$ – Table 8: additional condition and specification values added to parameter $t_{bit(RXD)}$ – Section 13: Figure 7 added – Section 17 “Appendix: ISO 11898-2:2016 parameter cross-reference list” added 			
TJF1051 v.4	20150115	Product data sheet	-	TJF1051 v.3
TJF1051 v.3	20130208	Product data sheet	-	TJF1051 v.2
TJF1051 v.2	20110512	Product data sheet	-	TJF1051 v.1
TJF1051 v.1	20100810	Product data sheet	-	-

19. Legal information

20. Data sheet status

Document status ^{[1][2]}	Product status ^[3]	Definition
Objective [short] data sheet	Development	This document contains data from the objective specification for product development.
Preliminary [short] data sheet	Qualification	This document contains data from the preliminary specification.
Product [short] data sheet	Production	This document contains the product specification.

[1] Please consult the most recently issued document before initiating or completing a design.

[2] The term 'short data sheet' is explained in section "Definitions".

[3] The product status of device(s) described in this document may have changed since this document was published and may differ in case of multiple devices. The latest product status information is available on the Internet at URL <http://www.nxp.com>.

20.1 Definitions

Draft — The document is a draft version only. The content is still under internal review and subject to formal approval, which may result in modifications or additions. NXP Semiconductors does not give any representations or warranties as to the accuracy or completeness of information included herein and shall have no liability for the consequences of use of such information.

Short data sheet — A short data sheet is an extract from a full data sheet with the same product type number(s) and title. A short data sheet is intended for quick reference only and should not be relied upon to contain detailed and full information. For detailed and full information see the relevant full data sheet, which is available on request via the local NXP Semiconductors sales office. In case of any inconsistency or conflict with the short data sheet, the full data sheet shall prevail.

Product specification — The information and data provided in a Product data sheet shall define the specification of the product as agreed between NXP Semiconductors and its customer, unless NXP Semiconductors and customer have explicitly agreed otherwise in writing. In no event however, shall an agreement be valid in which the NXP Semiconductors product is deemed to offer functions and qualities beyond those described in the Product data sheet.

20.2 Disclaimers

Limited warranty and liability — Information in this document is believed to be accurate and reliable. However, NXP Semiconductors does not give any representations or warranties, expressed or implied, as to the accuracy or completeness of such information and shall have no liability for the consequences of use of such information. NXP Semiconductors takes no responsibility for the content in this document if provided by an information source outside of NXP Semiconductors.

In no event shall NXP Semiconductors be liable for any indirect, incidental, punitive, special or consequential damages (including - without limitation - lost profits, lost savings, business interruption, costs related to the removal or replacement of any products or rework charges) whether or not such damages are based on tort (including negligence), warranty, breach of contract or any other legal theory.

Notwithstanding any damages that customer might incur for any reason whatsoever, NXP Semiconductors' aggregate and cumulative liability towards customer for the products described herein shall be limited in accordance with the *Terms and conditions of commercial sale* of NXP Semiconductors.

Right to make changes — NXP Semiconductors reserves the right to make changes to information published in this document, including without limitation specifications and product descriptions, at any time and without notice. This document supersedes and replaces all information supplied prior to the publication hereof.

Suitability for use — NXP Semiconductors products are not designed, authorized or warranted to be suitable for use in life support, life-critical or safety-critical systems or equipment, nor in applications where failure or malfunction of an NXP Semiconductors product can reasonably be expected to result in personal injury, death or severe property or environmental damage. NXP Semiconductors and its suppliers accept no liability for inclusion and/or use of NXP Semiconductors products in such equipment or applications and therefore such inclusion and/or use is at the customer's own risk.

Applications — Applications that are described herein for any of these products are for illustrative purposes only. NXP Semiconductors makes no representation or warranty that such applications will be suitable for the specified use without further testing or modification.

Customers are responsible for the design and operation of their applications and products using NXP Semiconductors products, and NXP Semiconductors accepts no liability for any assistance with applications or customer product design. It is customer's sole responsibility to determine whether the NXP Semiconductors product is suitable and fit for the customer's applications and products planned, as well as for the planned application and use of customer's third party customer(s). Customers should provide appropriate design and operating safeguards to minimize the risks associated with their applications and products.

NXP Semiconductors does not accept any liability related to any default, damage, costs or problem which is based on any weakness or default in the customer's applications or products, or the application or use by customer's third party customer(s). Customer is responsible for doing all necessary testing for the customer's applications and products using NXP Semiconductors products in order to avoid a default of the applications and the products or of the application or use by customer's third party customer(s). NXP does not accept any liability in this respect.

Limiting values — Stress above one or more limiting values (as defined in the Absolute Maximum Ratings System of IEC 60134) will cause permanent damage to the device. Limiting values are stress ratings only and (proper) operation of the device at these or any other conditions above those given in the Recommended operating conditions section (if present) or the Characteristics sections of this document is not warranted. Constant or repeated exposure to limiting values will permanently and irreversibly affect the quality and reliability of the device.

Terms and conditions of commercial sale — NXP Semiconductors products are sold subject to the general terms and conditions of commercial sale, as published at <http://www.nxp.com/profile/terms>, unless otherwise agreed in a valid written individual agreement. In case an individual agreement is concluded only the terms and conditions of the respective agreement shall apply. NXP Semiconductors hereby expressly objects to applying the customer's general terms and conditions with regard to the purchase of NXP Semiconductors products by customer.

No offer to sell or license — Nothing in this document may be interpreted or construed as an offer to sell products that is open for acceptance or the grant, conveyance or implication of any license under any copyrights, patents or other industrial or intellectual property rights.

Export control — This document as well as the item(s) described herein may be subject to export control regulations. Export might require a prior authorization from competent authorities.

Quick reference data — The Quick reference data is an extract of the product data given in the Limiting values and Characteristics sections of this document, and as such is not complete, exhaustive or legally binding.

Translations — A non-English (translated) version of a document is for reference only. The English version shall prevail in case of any discrepancy between the translated and English versions.

Non-automotive qualified products — Unless this data sheet expressly states that this specific NXP Semiconductors product is automotive qualified, the product is not suitable for automotive use. It is neither qualified nor tested

in accordance with automotive testing or application requirements. NXP Semiconductors accepts no liability for inclusion and/or use of non-automotive qualified products in automotive equipment or applications.

In the event that customer uses the product for design-in and use in automotive applications to automotive specifications and standards, customer (a) shall use the product without NXP Semiconductors' warranty of the product for such automotive applications, use and specifications, and (b) whenever customer uses the product for automotive applications beyond NXP Semiconductors' specifications such use shall be solely at customer's own risk, and (c) customer fully indemnifies NXP Semiconductors for any liability, damages or failed product claims resulting from customer design and use of the product for automotive applications beyond NXP Semiconductors' standard warranty and NXP Semiconductors' product specifications.

20.3 Trademarks

Notice: All referenced brands, product names, service names and trademarks are the property of their respective owners.

21. Contact information

For more information, please visit: <http://www.nxp.com>

For sales office addresses, please send an email to: salesaddresses@nxp.com

22. Contents

1	General description	1	21	Contact information	22
2	Features and benefits	1	22	Contents	23
2.1	General	1			
2.2	Low-power management	1			
2.3	Protection	2			
3	Quick reference data	2			
4	Ordering information	2			
5	Block diagram	3			
6	Pinning information	4			
6.1	Pinning	4			
6.2	Pin description	4			
7	Functional description	5			
7.1	Operating modes	5			
7.1.1	Normal mode	5			
7.1.2	Silent mode	5			
7.2	Fail-safe features	5			
7.2.1	TXD dominant time-out function	5			
7.2.2	Internal biasing of TXD and S input pins	6			
7.2.3	Undervoltage detection on pins V_{CC} and V_{IO} ..	6			
7.2.4	Overtemperature protection	6			
7.3	V_{IO} supply pin (TJF1051T/3)	6			
8	Limiting values	6			
9	Thermal characteristics	7			
10	Static characteristics	7			
11	Dynamic characteristics	10			
12	Application information	12			
12.1	Application diagram	12			
12.2	Application hints	12			
13	Test information	13			
14	Package outline	14			
15	Handling information	15			
16	Soldering of SMD packages	15			
16.1	Introduction to soldering	15			
16.2	Wave and reflow soldering	15			
16.3	Wave soldering	15			
16.4	Reflow soldering	16			
17	Appendix: ISO 11898-2:2016 parameter cross-reference list	18			
18	Revision history	20			
19	Legal information	21			
20	Data sheet status	21			
20.1	Definitions	21			
20.2	Disclaimers	21			
20.3	Trademarks	22			

Please be aware that important notices concerning this document and the product(s) described herein, have been included in section 'Legal information'.

© NXP N.V. 2016.

All rights reserved.

For more information, please visit: <http://www.nxp.com>

For sales office addresses, please send an email to: salesaddresses@nxp.com

Date of release: 13 July 2016

Document identifier: TJF1051