



Chipsmall Limited consists of a professional team with an average of over 10 year of expertise in the distribution of electronic components. Based in Hongkong, we have already established firm and mutual-benefit business relationships with customers from,Europe,America and south Asia,supplying obsolete and hard-to-find components to meet their specific needs.

With the principle of “Quality Parts,Customers Priority,Honest Operation,and Considerate Service”,our business mainly focus on the distribution of electronic components. Line cards we deal with include Microchip,ALPS,ROHM,Xilinx,Pulse,ON,Everlight and Freescale. Main products comprise IC,Modules,Potentiometer,IC Socket,Relay,Connector.Our parts cover such applications as commercial,industrial, and automotives areas.

We are looking forward to setting up business relationship with you and hope to provide you with the best service and solution. Let us make a better world for our industry!



## Contact us

Tel: +86-755-8981 8866 Fax: +86-755-8427 6832

Email & Skype: info@chipsmall.com Web: www.chipsmall.com

Address: A1208, Overseas Decoration Building, #122 Zhenhua RD., Futian, Shenzhen, China



TJG112711

REV	ECN	APP'D
-	6321	JT 2/5/09

INDEXING INDICATOR

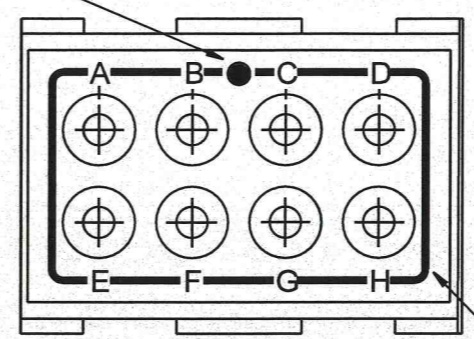

MARKING COLOR: WHITE

SEALING GROMMET

HOUSING

NOTES:

- MODULE MEETS ALL REQUIREMENTS OF SAE-AS81714/27, CLASS D, EXCEPT AS SHOWN.
- MODULE ASSEMBLY CONSTRUCTION:
  - A. HOUSING - POLYETHERIMIDE, COLOR: BLACK.
  - B. SEALING GROMMET - SILICONE PER A-A-59588, COLOR: BLUE.
  - C. INTERNAL SOCKET CONTACTS - COPPER ALLOY, GOLD PLATED PER MIL-G-45204, TYPE I, GRADE C, CLASS 1.
  - D. STUD - COPPER ALLOY, GOLD PLATED.
- MODULE MARKING AND IDENTIFICATION IS FLUSH WITH SURFACES, COLOR: WHITE.
- RECOMMENDED EXTERNAL PIN CONTACT SERVICE TOOLS -
  - A. CRIMP TOOL #M22520/1-101 WITH POSITIONER #M22520/1-02.
  - B. INSTALLING/REMOVAL TOOL #M81969/14-04, APCD #CNA078003.
- MODULE ACCEPTS -
  - A. MATING PIN CONTACTS #M39029/1-103, APCD #CNP072000
  - B. SEALING PLUGS #MS27488-12, APCD #CNA032403
- (9) PIN CONTACTS AND SEALING PLUGS SUPPLIED WITH EACH MODULE.
- MOUNTING HARDWARE SUPPLIED WITH EACH MODULE -
  - (2) FLAT WASHERS PER AN-960-C-10L
  - (1) LOCK WASHER PER MS35338-138
  - (1) NUT PER MS35650-304

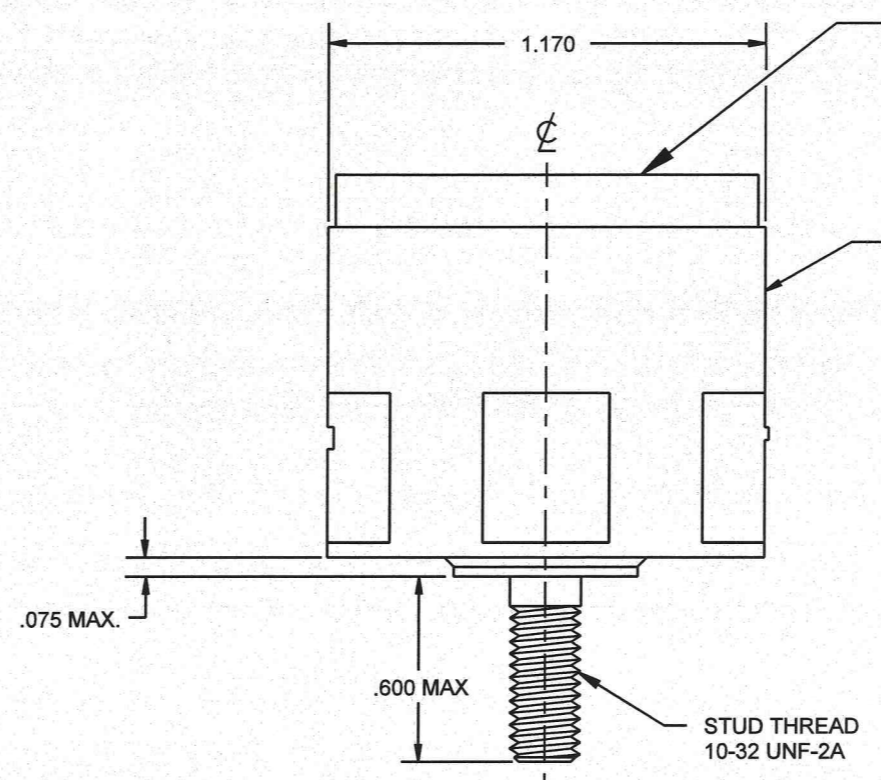
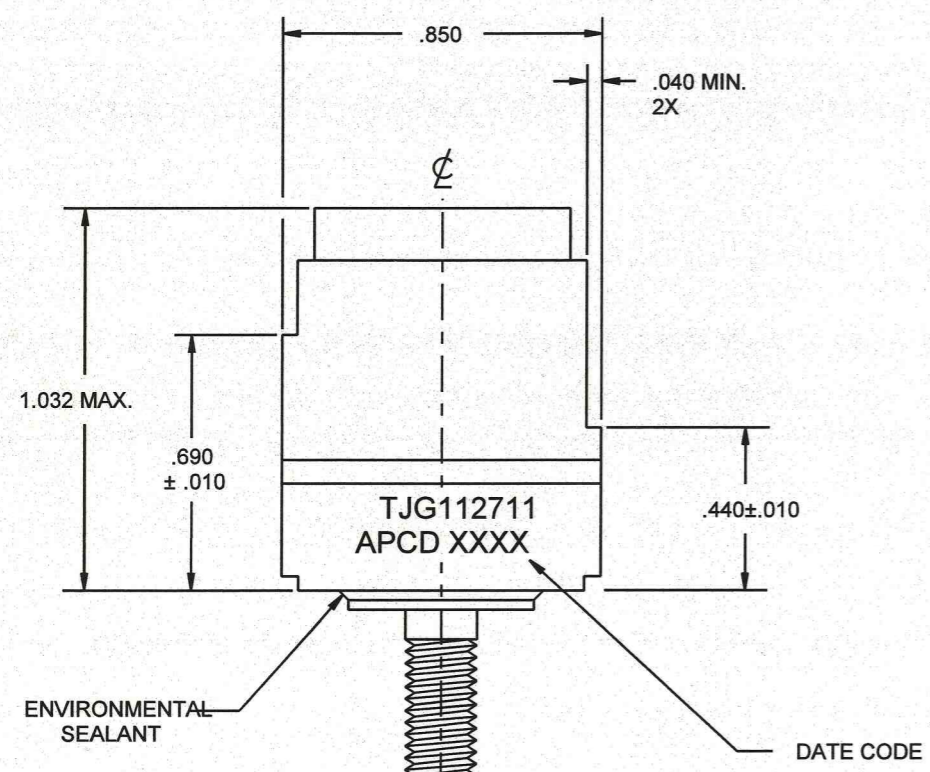

ENVIRONMENTAL SEALANT

DATE CODE

DIMENSIONS ANSI Y14.5M UNITS: INCHES Pro/E FILE	TOLERANCES .XX ± 0.01 .XXX ± 0.005 ANGLES ± 2.0°	PROJECTION 	<b>Amphenol Pcd</b> SPECIFICATION DRAWING		TITLE <b>TERMINAL JUNCTION GROUNDING MODULE, SIZE 12, CLASS D STAINLESS STEEL HARDWARE</b>		
			ENGR M. DiGIACOMO 1/26/09	SIZE <b>B</b>		DWG NO. <b>TJG112711</b>	REV -
ORIGINAL 	THIS DOCUMENT CONTAINS PROPRIETARY INFORMATION WHICH IS THE CONFIDENTIAL PROPERTY OF AMPHENOL PCD INC., BEVERLY, MA		CHKD 2/5/09	APPD 2/5/09	CODE: 58982	SCALE: 2.000	SHEET 1 OF 1

TJG112711

TJG112711