



Chipsmall Limited consists of a professional team with an average of over 10 year of expertise in the distribution of electronic components. Based in Hongkong, we have already established firm and mutual-benefit business relationships with customers from,Europe,America and south Asia,supplying obsolete and hard-to-find components to meet their specific needs.

With the principle of “Quality Parts,Customers Priority,Honest Operation,and Considerate Service”,our business mainly focus on the distribution of electronic components. Line cards we deal with include Microchip,ALPS,ROHM,Xilinx,Pulse,ON,Everlight and Freescale. Main products comprise IC,Modules,Potentiometer,IC Socket,Relay,Connector.Our parts cover such applications as commercial,industrial, and automotives areas.

We are looking forward to setting up business relationship with you and hope to provide you with the best service and solution. Let us make a better world for our industry!



## Contact us

Tel: +86-755-8981 8866 Fax: +86-755-8427 6832

Email & Skype: info@chipsmall.com Web: www.chipsmall.com

Address: A1208, Overseas Decoration Building, #122 Zhenhua RD., Futian, Shenzhen, China



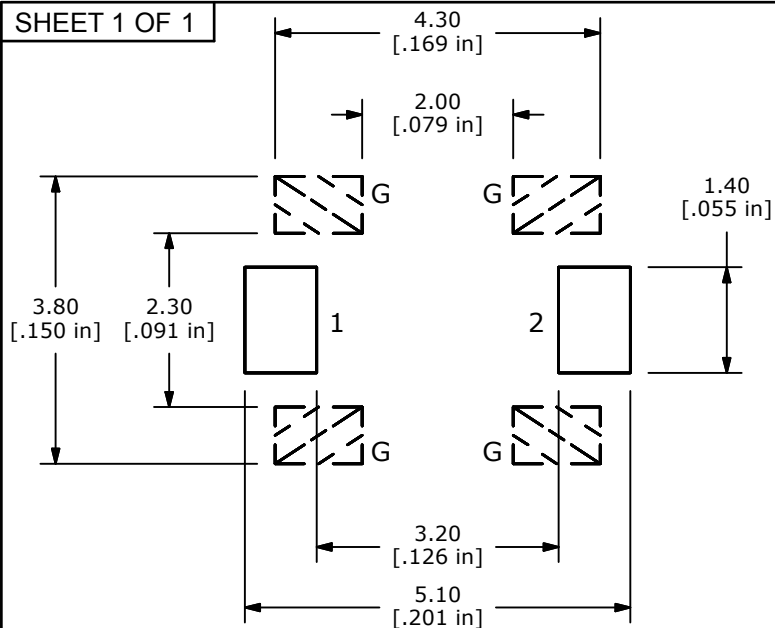

**PCB MOUNTING**  
GROUND TERMINALS ARE OPTIONAL

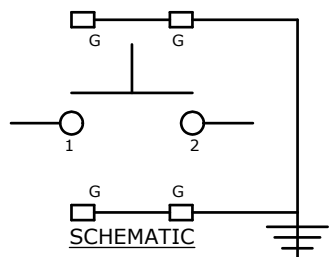

- NOTES:**
1. ALL DIMENSIONS IN MM
  2. GENERAL TOLERANCE: X.X=±0.4  
X.XX=±0.25
  3. TERM. NOS. FOR REFERENCE ONLY.
  4. RATING: 12VDC, 50mA
  - ▲ 5. OPERATING FORCE: 160 ± 50 GRAMS
  6. TRAVEL: 0.2mm ±0.1
  7. CONTACT RESISTANCE: 100 mΩ MAX. (INITIAL)
  8. MECHANICAL/ELECTRICAL LIFE 200,000 CYCLES MIN.
  9. PACKAGE: TAPE AND REEL - 2500 PIECES PER REEL
  10. ▲ DENOTES CRITICAL PARAMETER
  11. 2002/95/EC (ROHS) COMPLIANT

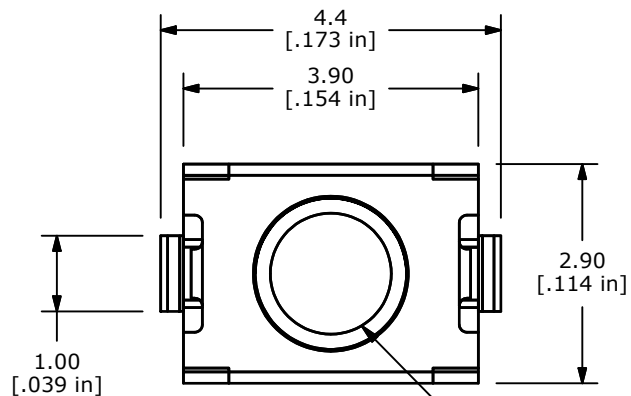

ACTUATOR COLOR: IVORY

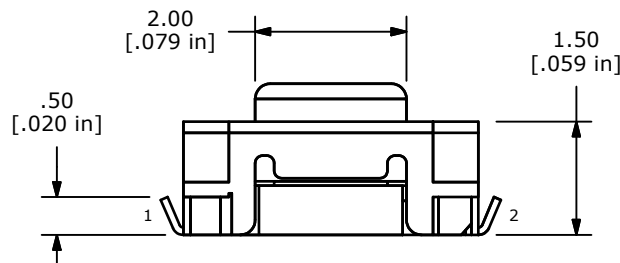
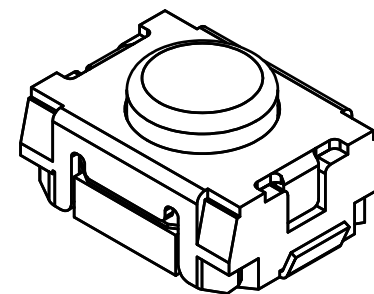

HOUSING COLOR: NATURAL

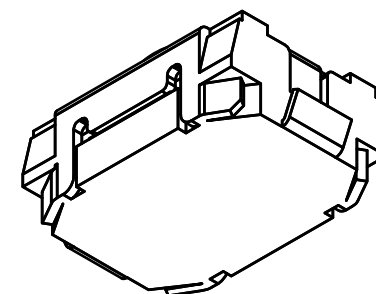
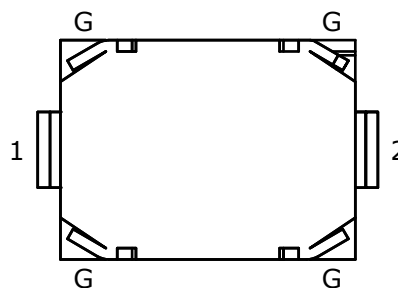
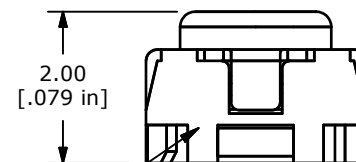

D	21622	ADDED HOUSING COLOR	10/14/14	AS
C	21300	REDRAW	11/13/13	EBP
B	21242	ADDED ACTUATOR COLOR	9/19/13	EBP
A	21000	Released For Production	2/1/2013	rc
REV	PCR NO	DESCRIPTION	DATE	BY

THE INFORMATION CONTAINED IN THIS DOCUMENT IS PROPRIETARY TO E-SWITCH AND IS NOT TO BE COPIED OR TRANSFERRED



TITLE TL1015AF160QG

SCALE	DATE	DR	DWG	REV
10:1	2/1/2013	rc	P420000	D