



Chipsmall Limited consists of a professional team with an average of over 10 year of expertise in the distribution of electronic components. Based in Hongkong, we have already established firm and mutual-benefit business relationships with customers from,Europe,America and south Asia,supplying obsolete and hard-to-find components to meet their specific needs.

With the principle of “Quality Parts,Customers Priority,Honest Operation,and Considerate Service”,our business mainly focus on the distribution of electronic components. Line cards we deal with include Microchip,ALPS,ROHM,Xilinx,Pulse,ON,Everlight and Freescale. Main products comprise IC,Modules,Potentiometer,IC Socket,Relay,Connector.Our parts cover such applications as commercial,industrial, and automotives areas.

We are looking forward to setting up business relationship with you and hope to provide you with the best service and solution. Let us make a better world for our industry!



Contact us

Tel: +86-755-8981 8866 Fax: +86-755-8427 6832

Email & Skype: info@chipsmall.com Web: www.chipsmall.com

Address: A1208, Overseas Decoration Building, #122 Zhenhua RD., Futian, Shenzhen, China



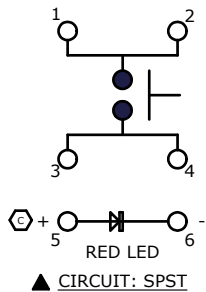
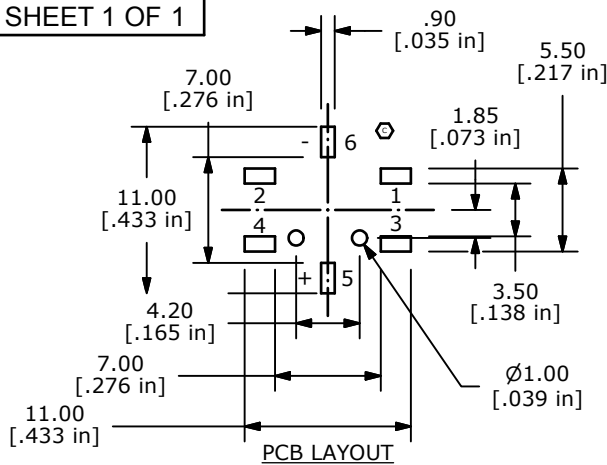

- NOTES:
1. ALL DIMENSIONS IN MM [INCH]
 2. GENERAL TOLERANCE: X.X=±0.4
X.XX=±0.25
 3. CONTACT RATING: 50mA @ 12VDC
 4. CONTACT RESISTANCE: 100 mΩ MAX.
 5. INSULATION RESISTANCE: 100MΩ MIN @ 500VDC.
 - ▲ 6. OPERATING FORCE: 100 ± 50gf
 7. TRAVEL: 0.2 ± 0.1mm
 8. OPERATING TEMPERATURE: -25°C TO + 70°C
 9. OPERATING LIFE: 200,000 CYCLES
 - ▲ 10. LED: RED
 11. ▲ DENOTES CRITICAL PARAMETERS
 12. 2002/95/EC (ROHS) COMPLIANT
 13. PARTS TO BE PACKAGED IN TAPE & REEL, 450 PIECES PER REEL

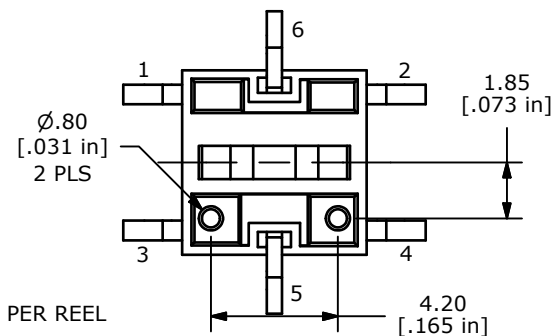
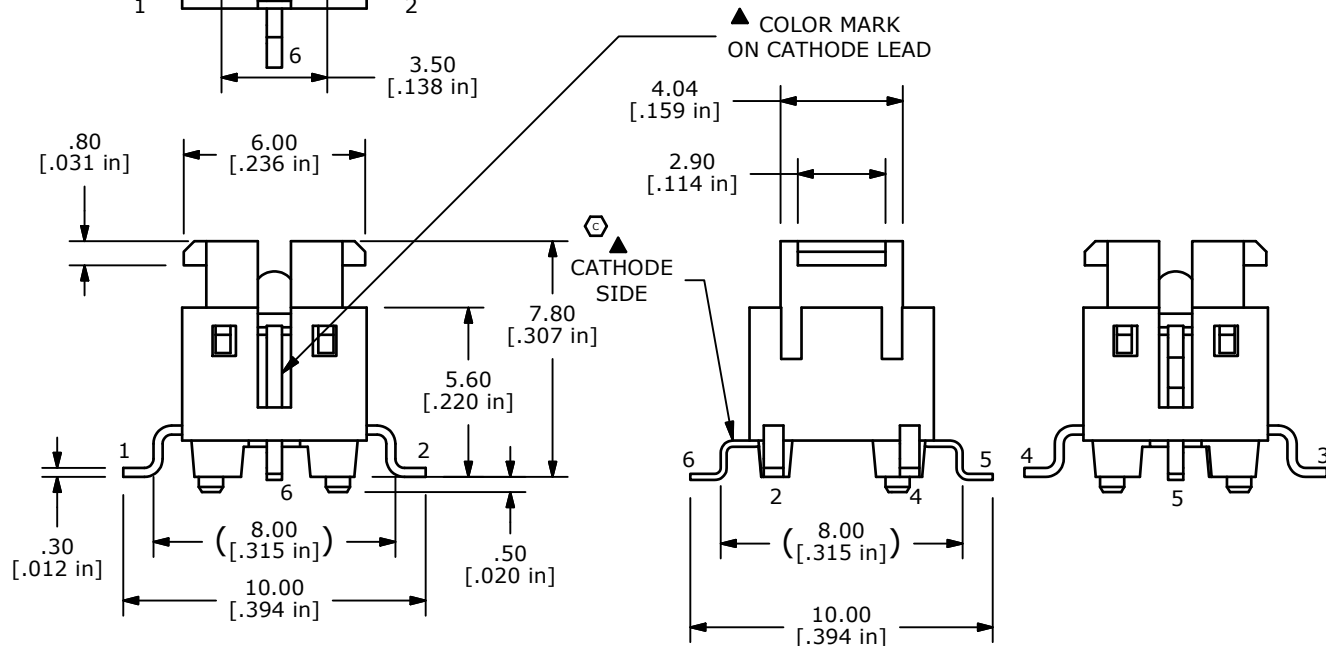
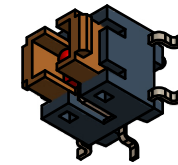
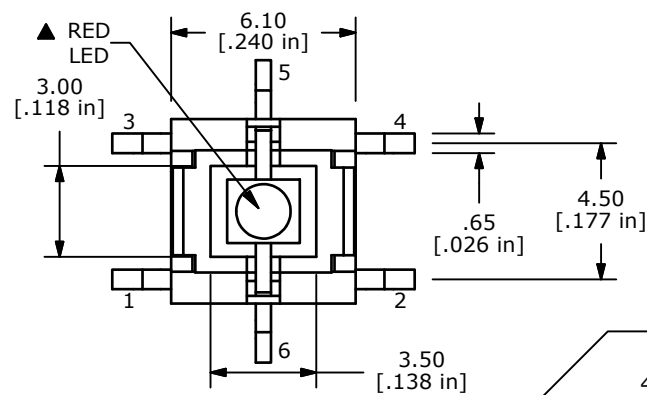

▲ LED SPECS	UNITS	VALUE
FORWARD CURRENT	mA	20
FORWARD VOLTAGE @20mA	V	1.8 TYP; 2.6 MAX
LUMINOUS INTENSITY @ 20mA	mcd	75 TYP

REV	PCR NO	DESCRIPTION	DATE	BY
C	21746	Changed cathode position to pin 6	12/29/14	rc
B	20570	Chg T&R qty from 500 to 450	4/25/12	rc
A	20373	New Release	12/12/11	rc



TITLE TL3240F100R				
SCALE 4	DATE 12/12/2011	DR rc	DWG N324003	REV C

THE INFORMATION CONTAINED IN THIS DOCUMENT IS PROPRIETARY TO E-SWITCH AND IS NOT TO BE COPIED OR TRANSFERRED