



Chipsmall Limited consists of a professional team with an average of over 10 year of expertise in the distribution of electronic components. Based in Hongkong, we have already established firm and mutual-benefit business relationships with customers from,Europe,America and south Asia,supplying obsolete and hard-to-find components to meet their specific needs.

With the principle of “Quality Parts,Customers Priority,Honest Operation,and Considerate Service”,our business mainly focus on the distribution of electronic components. Line cards we deal with include Microchip,ALPS,ROHM,Xilinx,Pulse,ON,Everlight and Freescale. Main products comprise IC,Modules,Potentiometer,IC Socket,Relay,Connector.Our parts cover such applications as commercial,industrial, and automotives areas.

We are looking forward to setting up business relationship with you and hope to provide you with the best service and solution. Let us make a better world for our industry!



Contact us

Tel: +86-755-8981 8866 Fax: +86-755-8427 6832

Email & Skype: info@chipsmall.com Web: www.chipsmall.com

Address: A1208, Overseas Decoration Building, #122 Zhenhua RD., Futian, Shenzhen, China



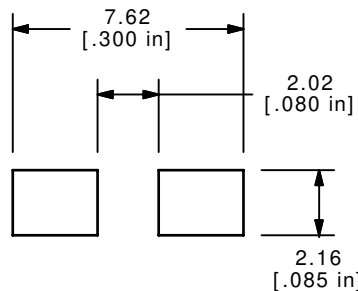

RECOMMENDED P.C.B. LAYOUT

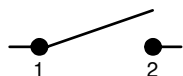

CIRCUIT: SPST

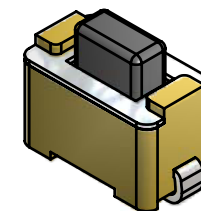
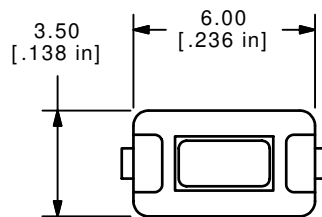

ISOMETRIC

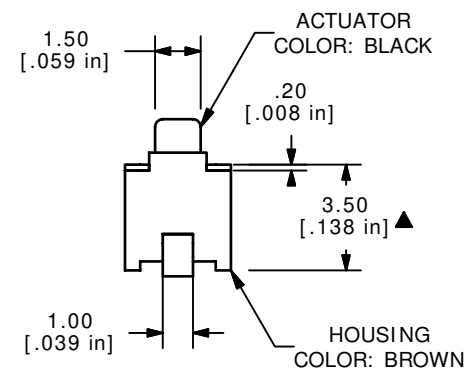
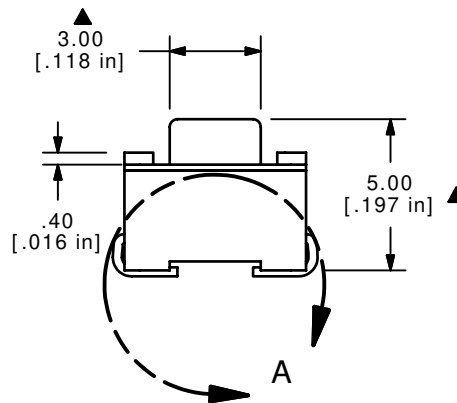

NOTES:

1. ALL DIMENSIONS IN MM [INCH]
2. GENERAL TOLERANCE: X.X= ± 0.4
X.XX= ± 0.25
3. TERM. NOS. FOR REFERENCE ONLY.
4. RATING: 50mA @ 12VDC
- ▲5. OPERATING FORCE: 180 ± 50 gms
6. TRAVEL: 0.25mm +0.2/-0.1
7. CONTACT RESISTANCE: 100 MILLI OHMS MAX. (INITIAL)
8. MECHANICAL/ELECTRICAL LIFE: 40,000 CYCLES.
- ▲9. CONTACT MATERIAL: SILVER
- ▲10. PACKAGE: TAPE AND REEL, 1800 PER
11. ▲ DENOTES CRITICAL PARAMETER
12. 2002/95/EC (ROHS) COMPLIANT

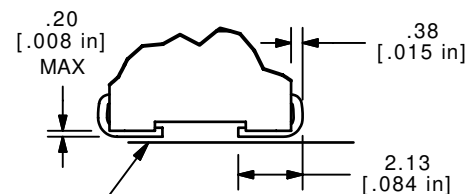

TERMINALS MUST BE COPLANAR WITHIN 0.10 [.004] TOTAL

DETAIL A

E-SWITCH®

D	16758	FIXED ACT, HOUSING COLOR	12/14/06	TN
C	16666	REVISED AND REDRAWN	11/15/2006	TN
REV	PCR NO	DESCRIPTION	DATE	BY

TITLE TL3302BF180QJ				
SCALE	DATE	DR	DWG	REV
4:1	12/14/2006	TN	P010541	D

THE INFORMATION CONTAINED IN THIS DOCUMENT IS PROPRIETARY TO E-SWITCH AND IS NOT TO BE COPIED OR TRANSFERRED