



Chipsmall Limited consists of a professional team with an average of over 10 year of expertise in the distribution of electronic components. Based in Hongkong, we have already established firm and mutual-benefit business relationships with customers from,Europe,America and south Asia,supplying obsolete and hard-to-find components to meet their specific needs.

With the principle of “Quality Parts,Customers Priority,Honest Operation,and Considerate Service”,our business mainly focus on the distribution of electronic components. Line cards we deal with include Microchip,ALPS,ROHM,Xilinx,Pulse,ON,Everlight and Freescale. Main products comprise IC,Modules,Potentiometer,IC Socket,Relay,Connector.Our parts cover such applications as commercial,industrial, and automotives areas.

We are looking forward to setting up business relationship with you and hope to provide you with the best service and solution. Let us make a better world for our industry!



## Contact us

Tel: +86-755-8981 8866 Fax: +86-755-8427 6832

Email & Skype: info@chipsmall.com Web: www.chipsmall.com

Address: A1208, Overseas Decoration Building, #122 Zhenhua RD., Futian, Shenzhen, China





# Infineon<sup>®</sup> LITIX<sup>™</sup> Basic

## TLD1312EL

3 Channel High Side Current Source

Data Sheet

Rev. 1.1, 2015-03-19

Automotive

<b>1</b>	<b>Overview</b>	<b>3</b>
<b>2</b>	<b>Block Diagram</b>	<b>5</b>
<b>3</b>	<b>Pin Configuration</b>	<b>6</b>
3.1	Pin Assignment	6
3.2	Pin Definitions and Functions	7
<b>4</b>	<b>General Product Characteristics</b>	<b>8</b>
4.1	Absolute Maximum Ratings	8
4.2	Functional Range	9
4.3	Thermal Resistance	9
<b>5</b>	<b>EN Pin</b>	<b>10</b>
5.1	EN Function	10
5.2	Internal Supply Pin	11
5.3	EN Unused	12
5.3.1	EN - Pull Up to VS	12
5.3.2	EN - Direct Connection to VS	12
<b>6</b>	<b>PWMI Pin</b>	<b>13</b>
6.1	PWM Dimming	13
6.2	Internal PWM Unit	14
6.3	Electrical Characteristics Internal Supply / EN / PWMI Pin	15
<b>7</b>	<b>IN_SET Pin</b>	<b>18</b>
7.1	Output Current Adjustment via RSET	18
7.2	Input Pin	18
7.3	Electrical Characteristics IN_SET Pin	20
<b>8</b>	<b>Power Stage</b>	<b>21</b>
8.1	Protection	21
8.1.1	Over Load Behavior	21
8.1.2	Reverse Battery Protection	21
8.2	Electrical Characteristics Power Stage	22
<b>9</b>	<b>Application Information</b>	<b>24</b>
9.1	Further Application Information	24
<b>10</b>	<b>Package Outlines</b>	<b>25</b>
<b>11</b>	<b>Revision History</b>	<b>26</b>



## 1 Overview

### Features

- 3 Channel device with integrated output stages (current sources), optimized to drive LEDs
- Output current up to 120mA per channel
- Low current consumption in sleep mode
- PWM-operation supported via VS- and EN-pin
- Integrated PWM dimming engine to provide two LED brightness levels without external logic (e.g.  $\mu\text{C}$ )
- Output current adjustable via external low power resistor and possibility to connect PTC resistor for LED protection during over temperature conditions
- Reverse polarity protection
- Overload protection
- Undervoltage detection
- Wide temperature range:  $-40\text{ }^\circ\text{C} < T_j < 150\text{ }^\circ\text{C}$
- PG-SSOP14 package with exposed heatslug
- Green Product (RoHS compliant)
- AEC Qualified



**PG-SSOP14**

### Description

The LITIX™ Basic TLD1312EL is a three channel high side driver IC with integrated output stages. It is designed to control LEDs with a current up to 120 mA. In typical automotive applications the device is capable to drive i.e. 3 red LEDs per chain (total 9 LEDs) with a current up to 60mA, which is limited by thermal cooling aspects. The output current is controlled practically independent of load and supply voltage changes.

**Table 1 Product Summary**

Operating voltage	$V_{S(\text{nom})}$	5.5 V... 40 V
Maximum voltage	$V_{S(\text{max})}$ $V_{\text{OUTx}(\text{max})}$	40 V
Nominal output (load) current	$I_{\text{OUTx}(\text{nom})}$	60 mA when using a supply voltage range of 8V - 18V (e.g. Automotive car battery). Currents up to $I_{\text{OUT}(\text{max})}$ possible in applications with low thermal resistance $R_{\text{thJA}}$
Maximum output (load) current	$I_{\text{OUTx}(\text{max})}$	120 mA; depending on thermal resistance $R_{\text{thJA}}$

Type	Package	Marking
TLD1312EL	PG-SSOP14	TLD1312EL

**Table 1 Product Summary**

Output current accuracy at $R_{SET} = 12\text{ k}\Omega$	$k_{LT}$	$750 \pm 7\%$
Current consumption in sleep mode	$I_{S(sleep,typ)}$	$0.1\ \mu\text{A}$

**Protective functions**

- ESD protection
- Under voltage lock out
- Over Load protection
- Over Temperature protection
- Reverse Polarity protection

**Applications**

Designed for exterior LED lighting applications such as tail/brake light, turn indicator, position light, side marker,...

The device is also well suited for interior LED lighting applications such as ambient lighting, interior illumination and dash board lighting.

## 2 Block Diagram

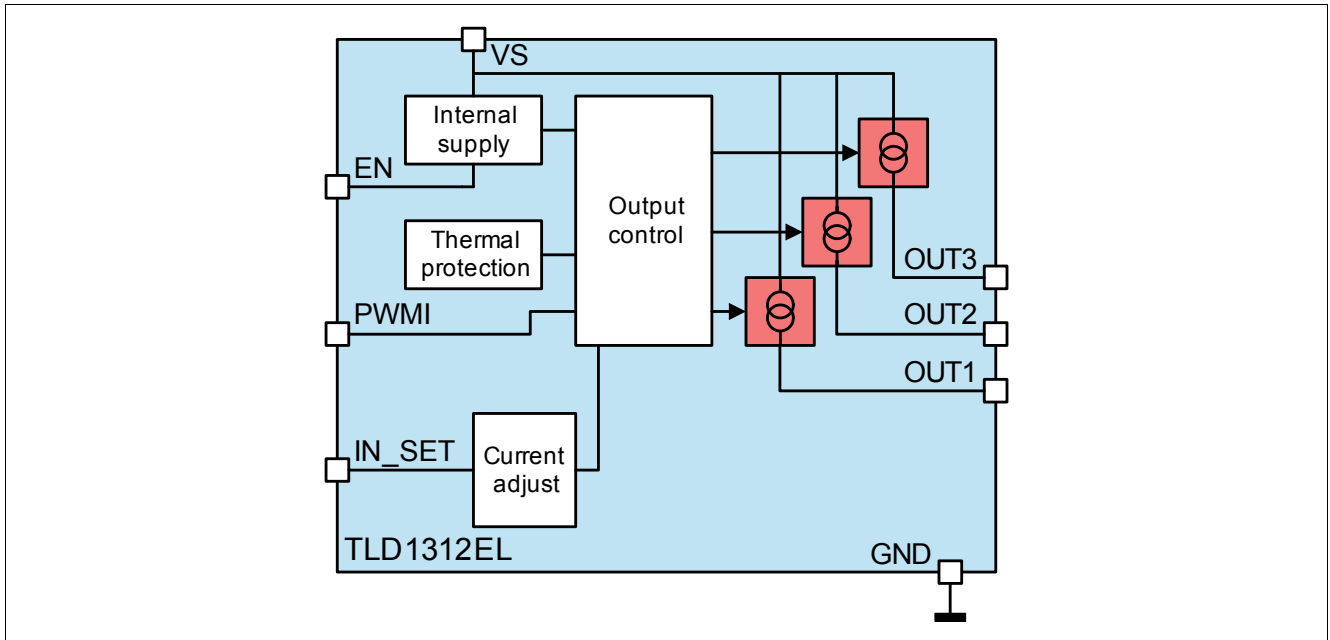

Figure 1 Basic Block Diagram

### 3 Pin Configuration

#### 3.1 Pin Assignment

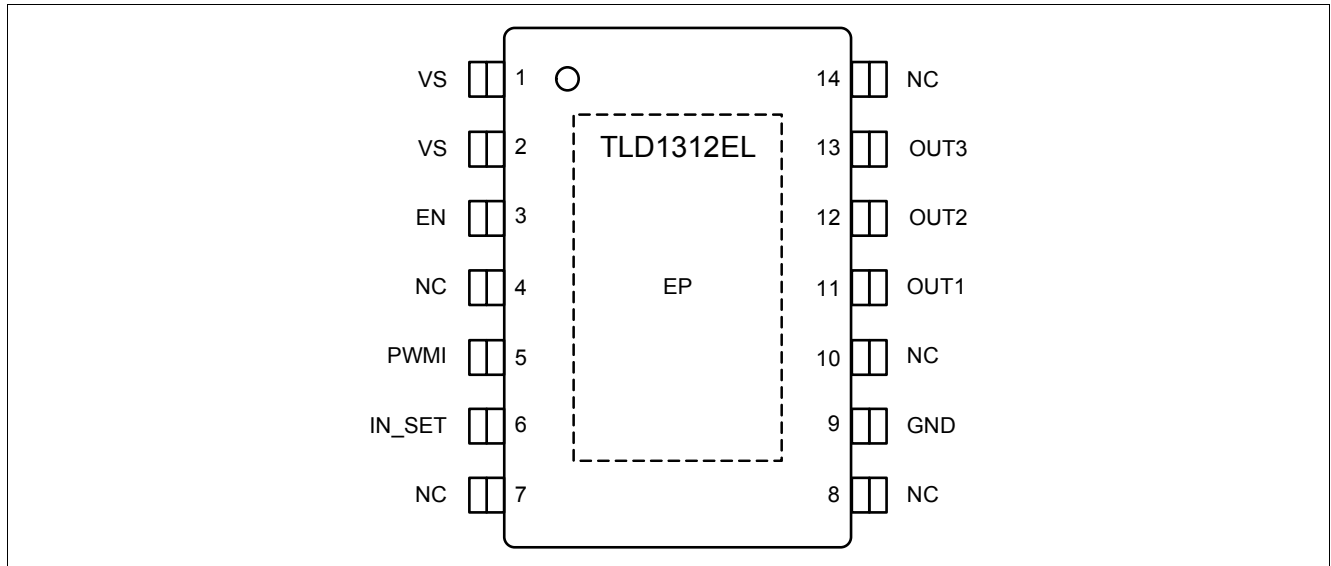

Figure 2 Pin Configuration

### 3.2 Pin Definitions and Functions

Pin	Symbol	Input/ Output	Function
1, 2	VS	–	<b>Supply Voltage</b> ; battery supply, connect a decoupling capacitor (100 nF - 1 $\mu$ F) to GND
3	EN	I	<b>Enable pin</b>
4	NC	–	<b>Pin not connected</b>
5	PWMI	I/O	<b>PWM Input</b>
6	IN_SET	I/O	<b>Input / SET pin</b> ; Connect a low power resistor to adjust the output current
7	NC	–	<b>Pin not connected</b>
8	NC	–	<b>Pin not connected</b>
9	GND	–	<sup>1)</sup> <b>Ground</b>
10	NC	–	<b>Pin not connected</b>
11	OUT1	O	<b>Output 1</b>
12	OUT2	O	<b>Output 2</b>
13	OUT3	O	<b>Output 3</b>
14	NC	–	<b>Pin not connected</b>
Exposed Pad	GND	–	<sup>1)</sup> <b>Exposed Pad</b> ; connect to GND in application

1) Connect all GND-pins together.



## 4 General Product Characteristics

### 4.1 Absolute Maximum Ratings

#### Absolute Maximum Ratings <sup>1)</sup>

$T_j = -40\text{ °C}$  to  $+150\text{ °C}$ ; all voltages with respect to ground, positive current flowing into pin for input pins (I), positive currents flowing out of the I/O and output pins (O) (unless otherwise specified)

Pos.	Parameter	Symbol	Limit Values		Unit	Conditions
			Min.	Max.		
<b>Voltages</b>						
4.1.1	Supply voltage	$V_S$	-16	40	V	–
4.1.2	Input voltage EN	$V_{EN}$	-16	40	V	–
4.1.3	Input voltage EN related to $V_S$	$V_{EN(VS)}$	$V_S - 40$	$V_S + 16$	V	–
4.1.4	Input voltage EN related to $V_{OUTx}$	$V_{EN} - V_{OUTx}$	-16	40	V	–
4.1.5	Output voltage	$V_{OUTx}$	-1	40	V	–
4.1.6	Power stage voltage	$V_{PS}$	-16	40	V	–
	$V_{PS} = V_S - V_{OUTx}$					
4.1.7	Input voltage PWMI	$V_{PWMI}$	-0.3	6	V	–
4.1.8	IN_SET voltage	$V_{IN\_SET}$	-0.3	6	V	–
<b>Currents</b>						
4.1.9	IN_SET current	$I_{IN\_SET}$	–	2	mA	–
4.1.10	Output current	$I_{OUTx}$	–	130	mA	–
<b>Temperatures</b>						
4.1.11	Junction temperature	$T_j$	-40	150	°C	–
4.1.12	Storage temperature	$T_{stg}$	-55	150	°C	–
<b>ESD Susceptibility</b>						
4.1.13	ESD resistivity to GND	$V_{ESD}$	-2	2	kV	Human Body Model (100 pF via 1.5 kΩ) <sup>2)</sup>
4.1.14	ESD resistivity all pins to GND	$V_{ESD}$	-500	500	V	CDM <sup>3)</sup>
4.1.15	ESD resistivity corner pins to GND	$V_{ESD}$	-750	750	V	CDM <sup>3)</sup>

1) Not subject to production test, specified by design

2) ESD susceptibility, Human Body Model "HBM" according to ANSI/ESDA/JEDEC JS-001-2011

3) ESD susceptibility, Charged Device Model "CDM" according to JESD22-C101E

*Note: Stresses above the ones listed here may cause permanent damage to the device. Exposure to absolute maximum rating conditions for extended periods may affect device reliability.*

*Note: Integrated protection functions are designed to prevent IC destruction under fault conditions described in the data sheet. Fault conditions are considered as "outside" normal operating range. Protection functions are not designed for continuous repetitive operation.*

## 4.2 Functional Range

Pos.	Parameter	Symbol	Limit Values		Unit	Conditions
			Min.	Max.		
4.2.16	Supply voltage range for normal operation	$V_{S(nom)}$	5.5	40	V	–
4.2.17	Power on reset threshold	$V_{S(POR)}$	–	5	V	$V_{EN} = V_S$ $R_{SET} = 12\text{ k}\Omega$ $I_{OUTx} = 80\% I_{OUTx(nom)}$ $V_{OUTx} = 2.5\text{ V}$
4.2.18	Junction temperature	$T_j$	-40	150	°C	–

Note: Within the functional range the IC operates as described in the circuit description. The electrical characteristics are specified within the conditions given in the related electrical characteristics table.

## 4.3 Thermal Resistance

Pos.	Parameter	Symbol	Limit Values			Unit	Conditions
			Min.	Typ.	Max.		
4.3.1	Junction to Case	$R_{thJC}$	–	8	10	K/W	<sup>1) 2)</sup>
4.3.2	Junction to Ambient 1s0p board	$R_{thJA1}$	–	61	–	K/W	<sup>1) 3)</sup> $T_a = 85\text{ °C}$ $T_a = 135\text{ °C}$
			–	56	–		
4.3.3	Junction to Ambient 2s2p board	$R_{thJA2}$	–	45	–	K/W	<sup>1) 4)</sup> $T_a = 85\text{ °C}$ $T_a = 135\text{ °C}$
			–	43	–		

- 1) Not subject to production test, specified by design. Based on simulation results.
- 2) Specified  $R_{thJC}$  value is simulated at natural convection on a cold plate setup (all pins and the exposed Pad are fixed to ambient temperature).  $T_a = 85\text{ °C}$ , Total power dissipation 1.5 W.
- 3) The  $R_{thJA}$  values are according to Jedec JESD51-3 at natural convection on 1s0p FR4 board. The product (chip + package) was simulated on a 76.2 x 114.3 x 1.5 mm<sup>3</sup> board with 70µm Cu, 300 mm<sup>2</sup> cooling area. Total power dissipation 1.5 W distributed statically and homogeneously over all power stages.
- 4) The  $R_{thJA}$  values are according to Jedec JESD51-5,-7 at natural convection on 2s2p FR4 board. The product (chip + package) was simulated on a 76.2 x 114.3 x 1.5 mm<sup>3</sup> board with 2 inner copper layers (outside 2 x 70 µm Cu, inner 2 x 35µm Cu). Where applicable, a thermal via array under the exposed pad contacted the first inner copper layer. Total power dissipation 1.5 W distributed statically and homogeneously over all power stages.

## 5 EN Pin

The EN pin is a dual function pin:

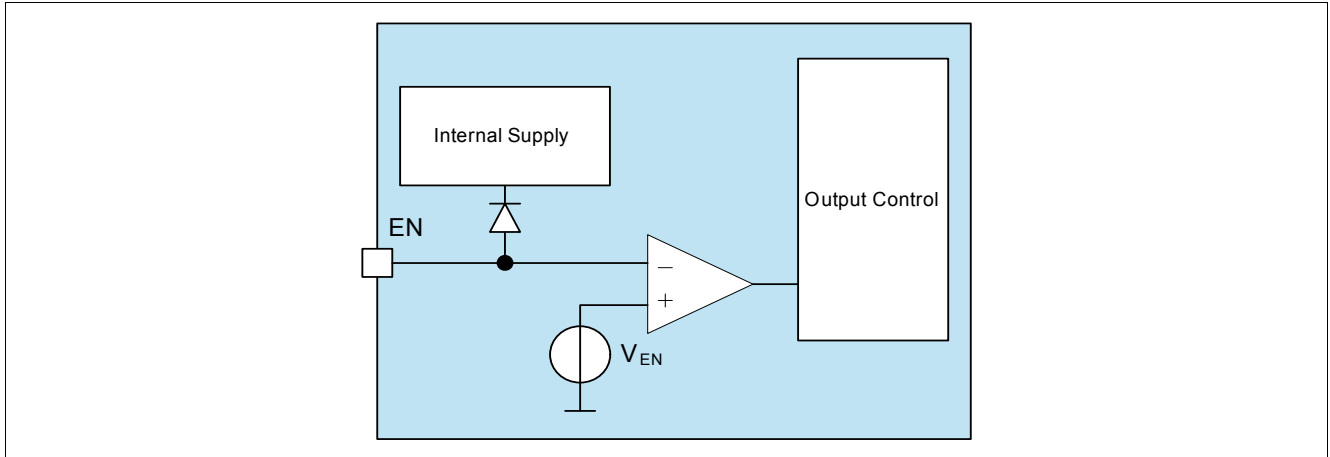

Figure 3 Block Diagram EN pin

Note: The current consumption at the EN-pin  $I_{EN}$  needs to be added to the total device current consumption. The total current consumption is the sum of the currents at the VS-pin  $I_S$  and the EN-pin  $I_{EN}$ .

### 5.1 EN Function

If the voltage at the pin EN is below a threshold of  $V_{EN(off)}$  the LITIX™ Basic IC will enter Sleep mode. In this state all internal functions are switched off, the current consumption is reduced to  $I_{S(sleep)}$ . A voltage above  $V_{EN(on)}$  at this pin enables the device after the Power on reset time  $t_{POR}$ .

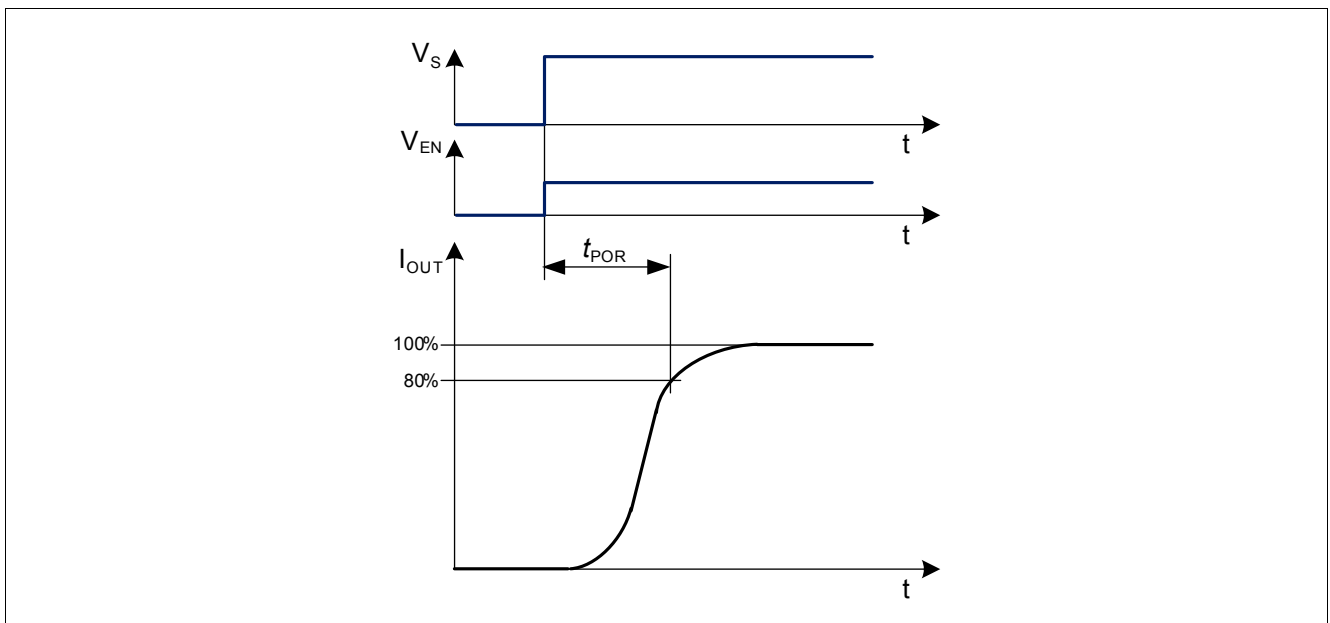

Figure 4 Power on reset

## 5.2 Internal Supply Pin

The EN pin can be used to supply the internal logic. There are two typical application conditions, where this feature can be used:

- 1) In “DC/DC control Buck” configurations, where the voltage  $V_S$  can be below 5.5V.
- 2) In configurations, where a PWM signal is applied at the Vbatt pin of a light module. The buffer capacitor  $C_{BUF}$  is used to supply the LITIX™ Basic IC during Vbatt low ( $V_S$  low) periods. This feature can be used to minimize the turn-on time to the values specified in **Pos. 8.2.13**. Otherwise, the power-on reset delay time  $t_{POR}$  (**Pos. 6.3.5**) has to be considered.

The capacitor can be calculated using the following formula:

$$C_{BUF} = t_{LOW(max)} \cdot \frac{I_{EN(LS)}}{V_S - V_{D1} - V_{S(POR)}} \quad (1)$$

See also a typical application drawing in **Chapter 9**.

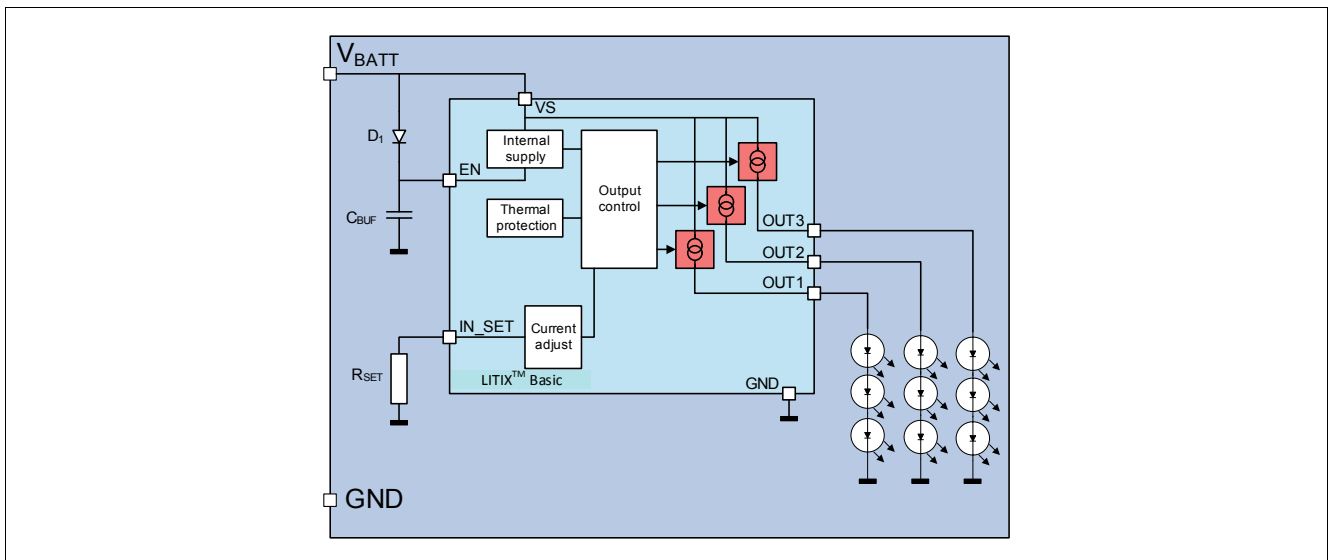

**Figure 5** External circuit when applying a fast PWM signal on  $V_{BATT}$

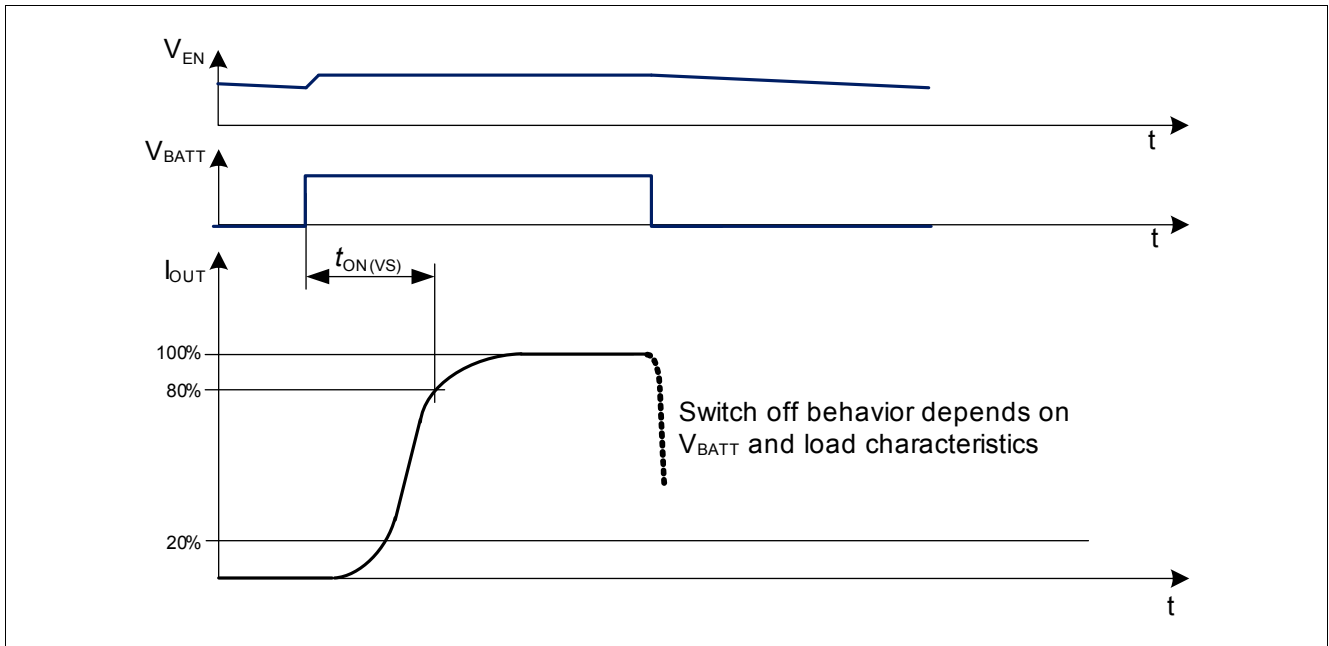

**Figure 6** Typical waveforms when applying a fast PWM signal on  $V_{BATT}$

The parameter  $t_{ON(VS)}$  is defined at [Pos. 8.2.13](#). The parameter  $t_{OFF(VS)}$  depends on the load and supply voltage  $V_{BATT}$  characteristics.

### 5.3 EN Unused

In case of an unused EN pin, there are two different ways to connect it:

#### 5.3.1 EN - Pull Up to VS

The EN pin can be connected with a pull up resistor (e.g. 10 k $\Omega$ ) to  $V_s$  potential. In this configuration the LITIX™ Basic IC is always enabled.

#### 5.3.2 EN - Direct Connection to VS

The EN pin can be connected directly to the VS pin (IC always enabled). This configuration has the advantage (compared to the configuration described in [Chapter 5.3.1](#)) that no additional external component is required.



## 6 PWMI Pin

The PWMI pin is designed as a dual function pin.

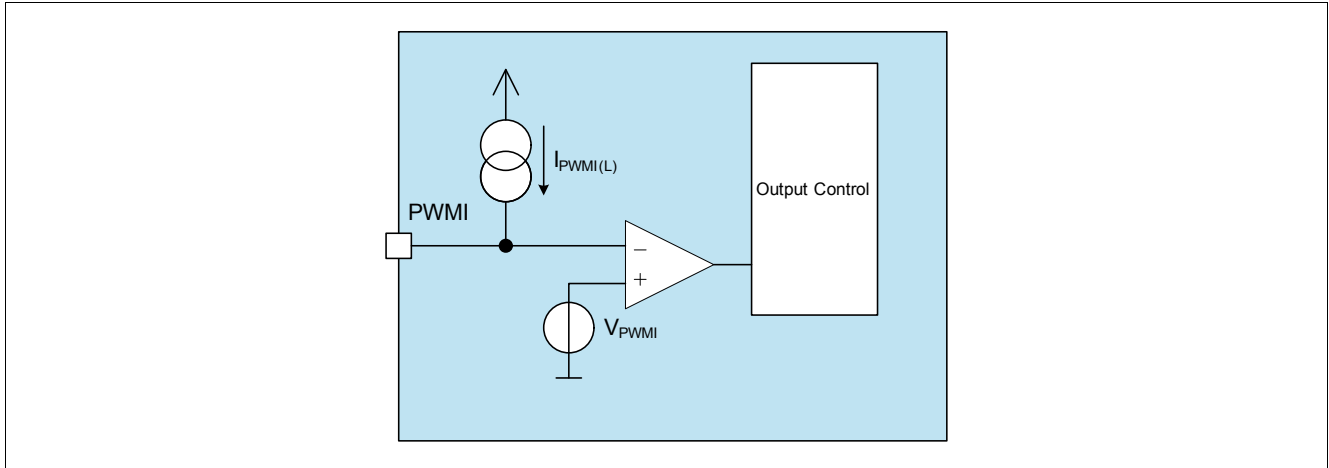

**Figure 7 Block Diagram PWMI pin**

The pin can be used for PWM-dimming via a push-pull stage of a micro controller, which is connecting the PWMI-pin to a low or high potential.

*Note: The micro controller's push-pull stage has to be able to sink currents according to [Pos. 6.3.15](#) to activate the device.*

Furthermore, the device offers also an internal PWM unit by connecting an external-RC network according to [Figure 10](#).

### 6.1 PWM Dimming

A PWM signal can be applied at the PWMI pin for LED brightness regulation of all 3 output stages. The dimming frequency can be adjusted in a very wide range (e.g. 400 Hz). The PWMI pin is low active. Turn on/off thresholds  $V_{PWMI(L)}$  and  $V_{PWMI(H)}$  are specified in parameters [Pos. 6.3.12](#) and [Pos. 6.3.13](#).

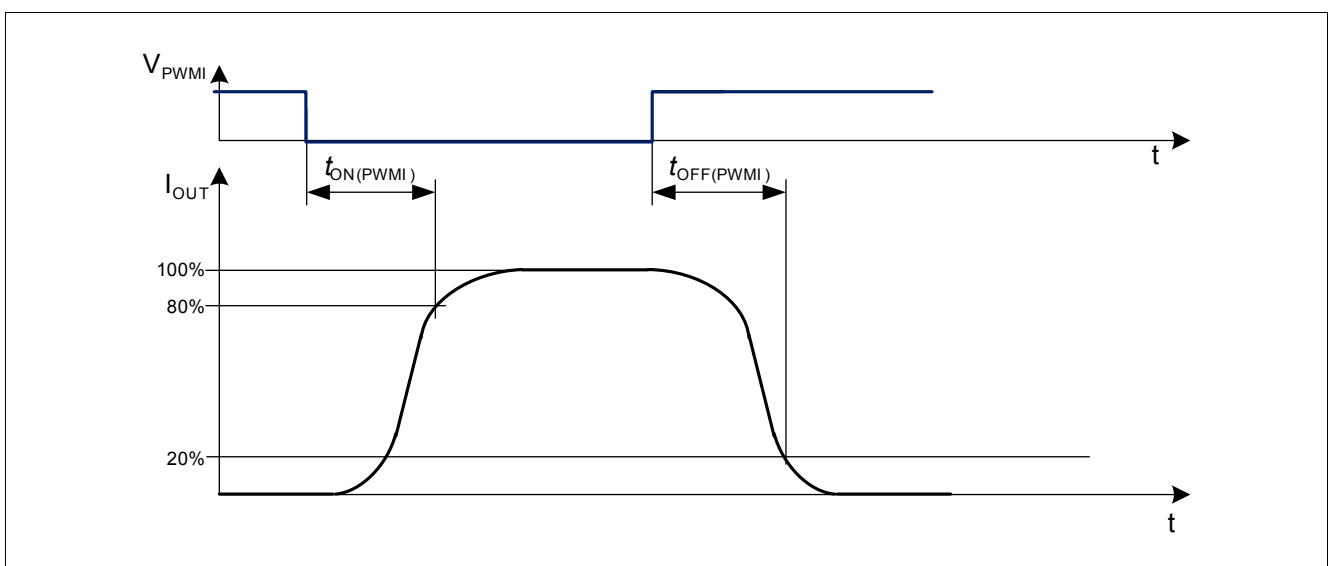

**Figure 8 Turn on and Turn off time for PWMI pin usage**

## 6.2 Internal PWM Unit

Connecting a resistor and a capacitor in parallel on the PWMI pin enables the internal pulse width modulation unit. The following figure shows the charging and discharging defined by the RC-network according to [Figure 10](#) and the internal PWM unit.

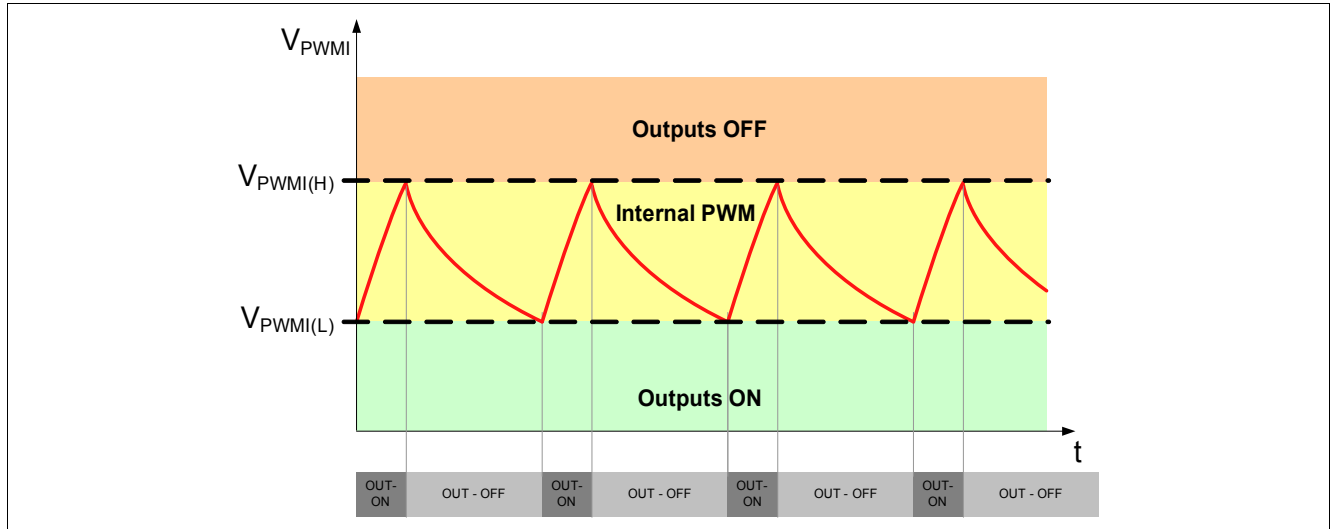

**Figure 9 PWMI operating voltages**

The PWM Duty cycle (DC) and the PWM frequency can be adjusted using the formulas below. Please use only typical values of  $V_{PWMI(L)}$ ,  $V_{PWMI(H)}$  and  $I_{PWMI(on)}$  for the calculation of  $t_{PWMI(on)}$  and  $t_{PWMI(off)}$  (as described in [Pos. 6.3.12](#) to [Pos. 6.3.15](#)).

$$t_{PWMI(on)} = -R_{PWMI} \cdot C_{PWMI} \cdot \text{LN} \left( \frac{V_{PWMI(H)} - I_{PWMI(on)} \cdot R_{PWMI}}{V_{PWMI(L)} - I_{PWMI(on)} \cdot R_{PWMI}} \right) \quad (2)$$

$$t_{PWMI(off)} = R_{PWMI} \cdot C_{PWMI} \cdot \text{LN} \left( \frac{V_{PWMI(H)}}{V_{PWMI(L)}} \right) \quad (3)$$

$$f_{PWMI} = \frac{1}{t_{PWMI(on)} + t_{PWMI(off)}} \quad (4)$$

$$DC = t_{PWMI(on)} \cdot f_{PWMI} \quad (5)$$

Out of this equations the required  $C_{PWMI}$  and  $R_{PWMI}$  can be calculated:

$$C_{PWMI} = \frac{-I_{PWMI(on)} \cdot t_{PWMI(off)} \cdot \left[ \left( \frac{V_{PWMI(L)}}{V_{PWMI(H)}} \right)^{\frac{t_{PWMI(on)}}{t_{PWMI(off)}}} - 1 \right]}{\text{LN} \left( \frac{V_{PWMI(L)}}{V_{PWMI(H)}} \right) \cdot \left[ V_{PWMI(L)} \cdot \left( \frac{V_{PWMI(L)}}{V_{PWMI(H)}} \right)^{\frac{t_{PWMI(on)}}{t_{PWMI(off)}}} - V_{PWMI(H)} \right]} \quad (6)$$

$$R_{PWMI} = \frac{t_{PWMI(off)}}{C_{PWMI} \cdot \text{LN} \left( \frac{V_{PWMI(H)}}{V_{PWMI(L)}} \right)} \quad (7)$$

See **Figure 10** for a typical external circuitry.

Note: In case of junction temperatures above  $T_{j(CRT)}$  (**Pos. 8.2.14**) the device provides a temperature dependent current reduction feature as described in **Chapter 8.1.1**. In case of output current reduction  $I_{IN\_SET}$  is reduced as well, which leads to increased turn on-times  $t_{PWMI(on)}$ , because the  $C_{PWMI}$  is charged slower. The turn off-time  $t_{PWMI(off)}$  remains the same.

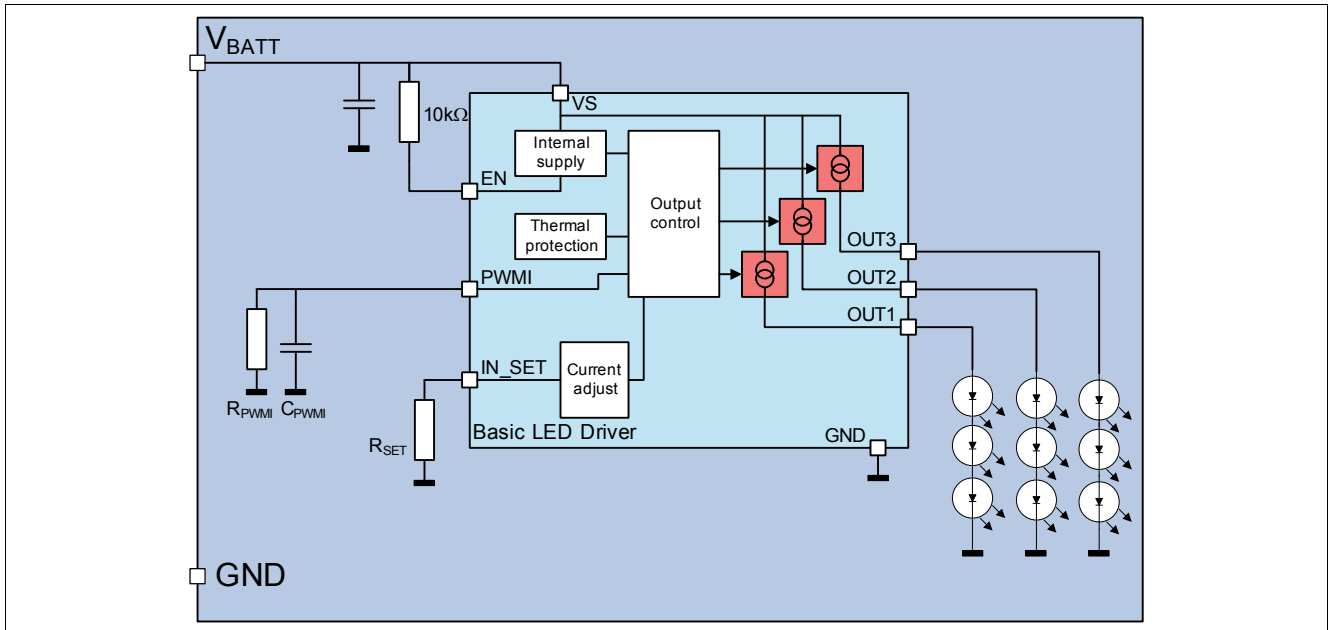

**Figure 10** Typical circuit using internal PWM unit

### 6.3 Electrical Characteristics Internal Supply / EN / PWMI Pin

#### Electrical Characteristics Internal Supply / EN / PWMI pin

Unless otherwise specified:  $V_S = 5.5 \text{ V to } 40 \text{ V}$ ,  $T_j = -40 \text{ }^\circ\text{C to } +150 \text{ }^\circ\text{C}$ ,  $R_{SET} = 12 \text{ k}\Omega$  all voltages with respect to ground, positive current flowing into pin for input pins (I), positive currents flowing out of the I/O and output pins (O) (unless otherwise specified)

Pos.	Parameter	Symbol	Limit Values			Unit	Conditions
			Min.	Typ.	Max.		
6.3.1	Current consumption, sleep mode	$I_{S(sleep)}$	–	0.1	2	$\mu\text{A}$	<sup>1)</sup> $V_{EN} = 0.5 \text{ V}$ $T_j < 85 \text{ }^\circ\text{C}$ $V_S = 18 \text{ V}$ $V_{OUTx} = 3.6 \text{ V}$
6.3.2	Current consumption, active mode	$I_{S(on)}$				mA	<sup>2)</sup> $V_{PWMI} = 0.5 \text{ V}$ $I_{IN\_SET} = 0 \text{ }\mu\text{A}$ $T_j < 105 \text{ }^\circ\text{C}$ $V_S = 18 \text{ V}$ $V_{OUTx} = 3.6\text{V}$ $V_{EN} = 5.5 \text{ V}$ $V_{EN} = 18 \text{ V}$ <sup>1)</sup> $R_{EN} = 10 \text{ k}\Omega$ between VS and EN-pin
			–	–	1.4		
			–	–	0.75		
			–	–	1.5		

**Electrical Characteristics Internal Supply / EN / PWMI pin (cont'd)**

Unless otherwise specified:  $V_S = 5.5\text{ V to }40\text{ V}$ ,  $T_j = -40\text{ °C to }+150\text{ °C}$ ,  $R_{SET} = 12\text{ k}\Omega$  all voltages with respect to ground, positive current flowing into pin for input pins (I), positive currents flowing out of the I/O and output pins (O) (unless otherwise specified)

Pos.	Parameter	Symbol	Limit Values			Unit	Conditions
			Min.	Typ.	Max.		
6.3.3	Current consumption, device disabled via IN_SET	$I_{S(dis,IN\_SET)}$	–	–	1.4	mA	<sup>2)</sup> $V_S = 18\text{ V}$ $T_j < 105\text{ °C}$ $V_{IN\_SET} = 5\text{ V}$ $V_{EN} = 5.5\text{ V}$ $V_{EN} = 18\text{ V}$ <sup>1)</sup> $R_{EN} = 10\text{ k}\Omega$ between VS and EN-pin
			–	–	0.7		
			–	–	1.4		
6.3.4	Current consumption, device disabled via PWMI	$I_{S(dis,PWMI)}$	–	–	1.6	mA	<sup>2)</sup> $V_S = 18\text{ V}$ $T_j < 105\text{ °C}$ $V_{PWMI} = 3.4\text{ V}$ $V_{EN} = 5.5\text{ V}$ $V_{EN} = 18\text{ V}$ <sup>1)</sup> $R_{EN} = 10\text{ k}\Omega$ between VS and EN-pin
			–	–	0.75		
			–	–	1.6		
6.3.5	Power-on reset delay time <sup>3)</sup>	$t_{POR}$	–	–	25	$\mu\text{s}$	<sup>1)</sup> $V_S = V_{EN} = 0 \rightarrow 13.5\text{ V}$ $V_{OUTx(nom)} = 3.6 \pm 0.3\text{ V}$ $I_{OUTx} = 80\% I_{OUTx(nom)}$
6.3.6	Required supply voltage for output activation	$V_{S(on)}$	–	–	4	V	$V_{EN} = 5.5\text{ V}$ $V_{OUTx} = 3\text{ V}$ $I_{OUTx} = 50\% I_{OUTx(nom)}$
6.3.7	Required supply voltage for current control	$V_{S(CC)}$	–	–	5.2	V	$V_{EN} = 5.5\text{ V}$ $V_{OUTx} = 3.6\text{ V}$ $I_{OUTx} \geq 90\% I_{OUTx(nom)}$
6.3.8	EN turn on threshold	$V_{EN(on)}$	–	–	2.5	V	–
6.3.9	EN turn off threshold	$V_{EN(off)}$	0.8	–	–	V	–
6.3.10	EN input current during low supply voltage	$I_{EN(LS)}$	–	–	1.8	mA	<sup>1)</sup> $V_S = 4.5\text{ V}$ $T_j < 105\text{ °C}$ $V_{EN} = 5.5\text{ V}$
6.3.11	EN high input current	$I_{EN(H)}$	–	–	0.1	mA	$T_j < 105\text{ °C}$ $V_S = 13.5\text{ V}, V_{EN} = 5.5\text{ V}$ $V_S = 18\text{ V}, V_{EN} = 5.5\text{ V}$ $V_S = V_{EN} = 18\text{ V}$ <sup>1)</sup> $V_S = 18\text{ V}, R_{EN} = 10\text{ k}\Omega$ between VS and EN-pin
			–	–	0.1		
			–	–	1.65		
			–	–	0.45		
6.3.12	PWMI (active low) Switching low threshold (outputs on)	$V_{PWMI(L)}$	1.5	1.85	2.3	V	<sup>1)4)</sup> $V_S = 8...18\text{ V}$
6.3.13	PWMI(active low) Switching high threshold (outputs off)	$V_{PWMI(H)}$	2.45	2.85	3.2	V	<sup>1)4)5)</sup> $V_S = 8...18\text{ V}$

**Electrical Characteristics Internal Supply / EN / PWMI pin (cont'd)**

Unless otherwise specified:  $V_S = 5.5 \text{ V to } 40 \text{ V}$ ,  $T_j = -40 \text{ }^\circ\text{C to } +150 \text{ }^\circ\text{C}$ ,  $R_{SET} = 12 \text{ k}\Omega$  all voltages with respect to ground, positive current flowing into pin for input pins (I), positive currents flowing out of the I/O and output pins (O) (unless otherwise specified)

Pos.	Parameter	Symbol	Limit Values			Unit	Conditions
			Min.	Typ.	Max.		
6.3.14	PWMI Switching threshold difference $V_{PWMI(H)} - V_{PWMI(L)}$	$\Delta V_{PWMI}$	0.75	1	1.10	V	<sup>1)4)5)</sup> $V_S = 8...18 \text{ V}$
6.3.15	PWMI (active low) Low input current with active channels (voltage < $V_{PWMI(L)}$ )	$I_{PWMI(on)}$	$I_{IN\_SET}$ *3.1	$I_{IN\_SET}$ *4	$I_{IN\_SET}$ *4.9	$\mu\text{A}$	<sup>1)</sup> $T_j = 25...115 \text{ }^\circ\text{C}$ $I_{IN\_SET} = 100 \text{ } \mu\text{A}$ $V_{PWMI} = 1.7 \text{ V}$ $V_{EN} = 5.5 \text{ V}$ $V_S = 8...18 \text{ V}$
6.3.16	PWMI(active low) High input current	$I_{PWMI(off)}$	-5	–	5	$\mu\text{A}$	$V_{PWMI} = 5 \text{ V}$ $V_{EN} = 5.5 \text{ V}$ $V_S = 8...18 \text{ V}$

1) Not subject to production test, specified by design

2) The total device current consumption is the sum of the currents  $I_S$  and  $I_{EN(H)}$ , please refer to [Pos. 6.3.11](#)

3) See also [Figure 4](#)

4) Parameter valid if an external PWM signal is applied

5) If TTL level compatibility is required, use  $\mu\text{C}$  open drain output with pull up resistor



## 7 IN\_SET Pin

The IN\_SET pin is a multiple function pin for output current definition and input:

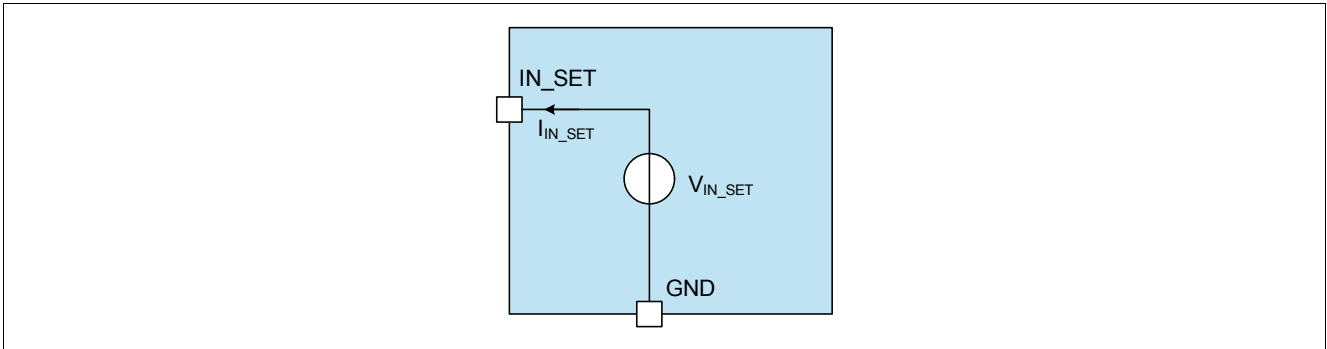

Figure 11 Block Diagram IN\_SET pin

### 7.1 Output Current Adjustment via RSET

The output current for all three channels can only be adjusted simultaneously. The current adjustment can be done by placing a low power resistor ( $R_{SET}$ ) at the IN\_SET pin to ground. The dimensioning of the resistor can be done using the formula below:

$$R_{SET} = \frac{k}{I_{OUT}} \tag{8}$$

The gain factor  $k$  ( $R_{SET}$  \* output current) is specified in [Pos. 8.2.4](#) and [Pos. 8.2.5](#). The current through the  $R_{SET}$  is defined by the resistor itself and the reference voltage  $V_{IN\_SET(ref)}$ , which is applied to the IN\_SET during supplied device.

### 7.2 Input Pin

The IN\_SET pin can be connected via  $R_{SET}$  to the open-drain output of a  $\mu C$  or to an external NMOS transistor as described in [Figure 12](#). This signal can be used to turn off the output stages of the IC. A minimum IN\_SET current of  $I_{IN\_SET(act)}$  is required to turn on the output stages. This feature is implemented to prevent glimming of LEDs caused by leakage currents on the IN\_SET pin, see [Figure 14](#) for details.

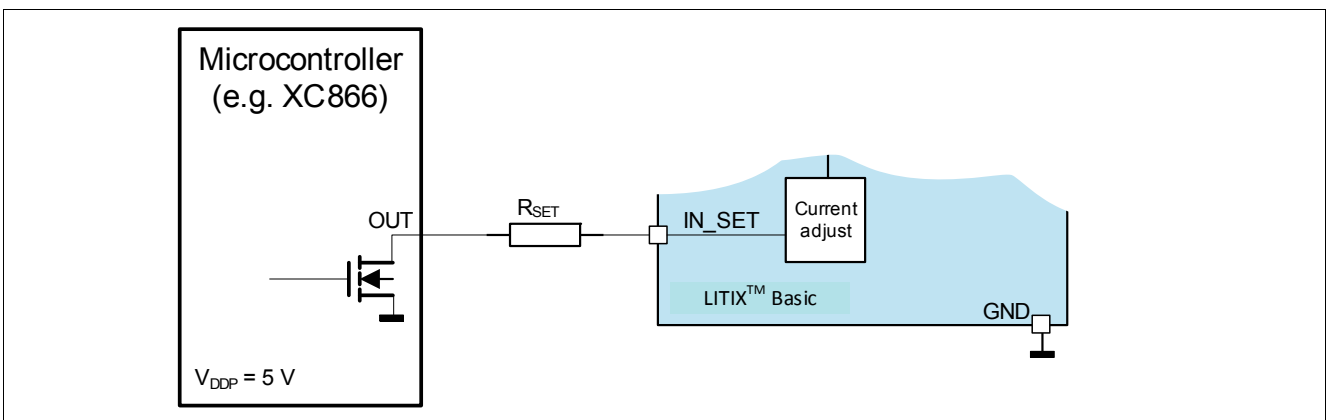

Figure 12 Schematics IN\_SET interface to  $\mu C$

The resulting switching times are shown in [Figure 13](#):

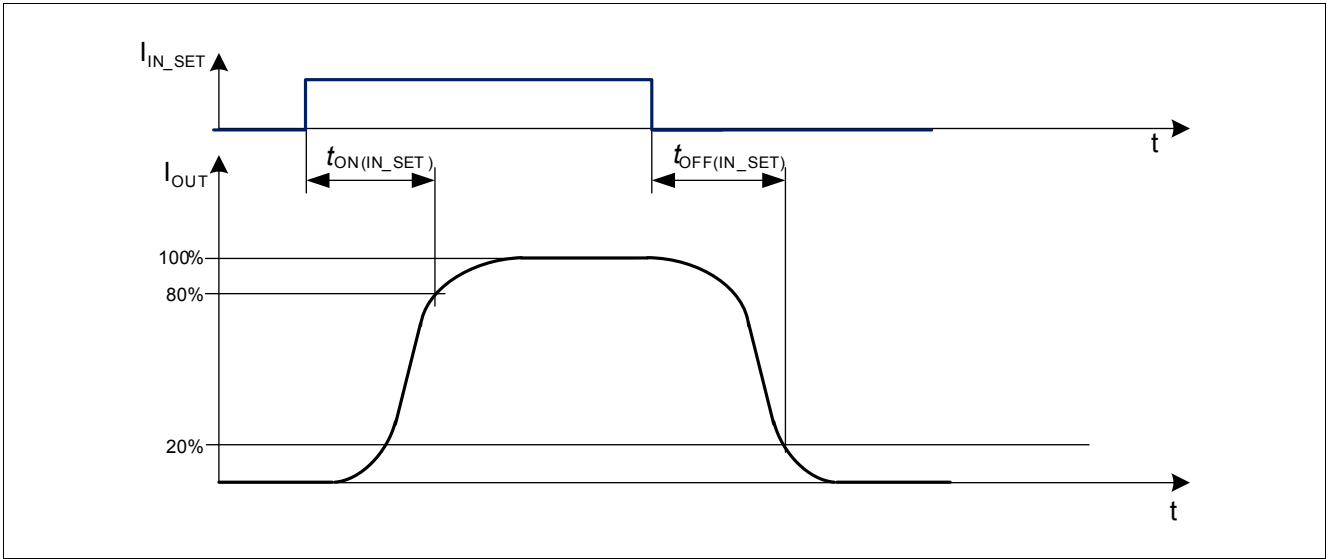

Figure 13 Switching times via IN\_SET

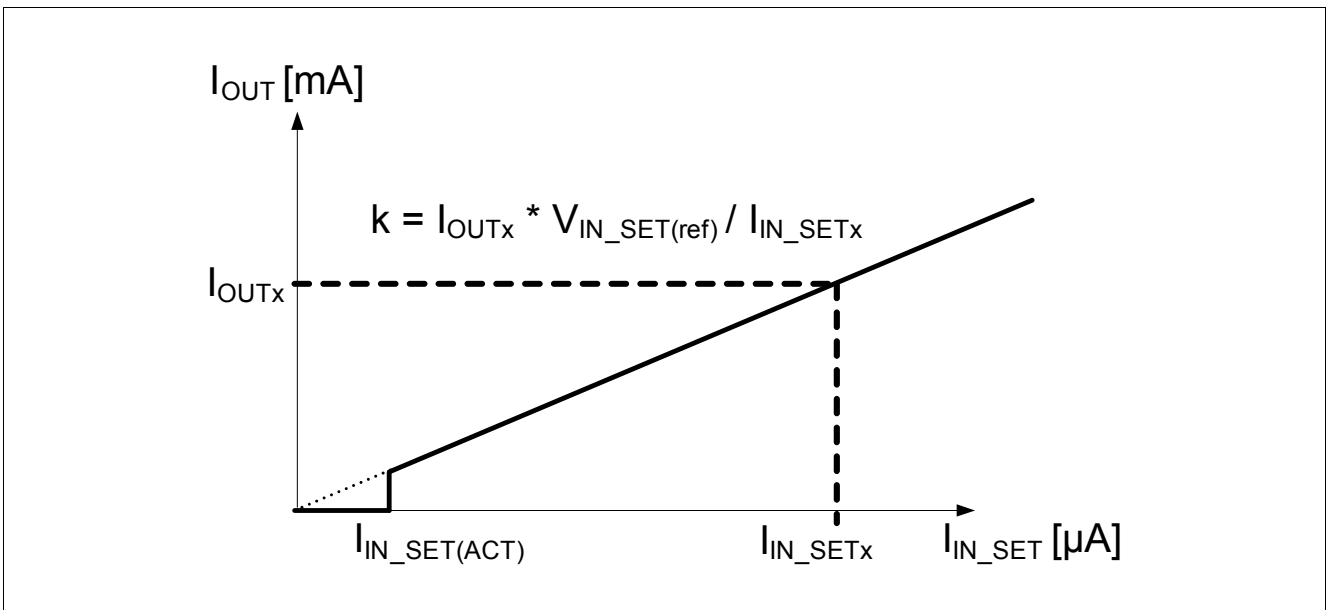

Figure 14  $I_{OUT}$  versus  $I_{INSET}$

### 7.3 Electrical Characteristics IN\_SET Pin

#### Electrical Characteristics IN\_SET pin

Unless otherwise specified:  $V_S = 5.5\text{ V to }40\text{ V}$ ,  $T_j = -40\text{ °C to }+150\text{ °C}$ ,  $R_{SET} = 12\text{ k}\Omega$ , all voltages with respect to ground, positive current flowing into pin for input pins (I), positive currents flowing out of the I/O and output pins (O) (unless otherwise specified)

Pos.	Parameter	Symbol	Limit Values			Unit	Conditions
			Min.	Typ.	Max.		
7.3.1	IN_SET reference voltage	$V_{IN\_SET(ref)}$	1.19	1.23	1.27	V	<sup>1)</sup> $V_{OUTx} = 3.6\text{ V}$ $T_j = 25\dots115\text{ °C}$
7.3.2	IN_SET activation current without turn on of output stages	$I_{IN\_SET(act)}$	2	–	15	$\mu\text{A}$	See <a href="#">Figure 14</a>

1) Not subject to production test, specified by design

## 8 Power Stage

The output stages are realized as high side current sources with a current of 120 mA. During off state the leakage current at the output stage is minimized in order to prevent a slightly glowing LED.

The maximum current of each channel is limited by the power dissipation and used PCB cooling areas (which results in the applications  $R_{thJA}$ ).

For an operating current control loop the supply and output voltages according to the following parameters have to be considered:

- Required supply voltage for current control  $V_{S(CC)}$ , **Pos. 6.3.7**
- Voltage drop over output stage during current control  $V_{PS(CC)}$ , **Pos. 8.2.6**
- Required output voltage for current control  $V_{OUTx(CC)}$ , **Pos. 8.2.7**

### 8.1 Protection

The device provides embedded protective functions, which are designed to prevent IC destruction under fault conditions described in this data sheet. Fault conditions are considered as “outside” normal operating range. Protective functions are neither designed for continuous nor for repetitive operation.

#### 8.1.1 Over Load Behavior

An over load detection circuit is integrated in the LITIX™ Basic IC. It is realized by a temperature monitoring of the output stages (OUTx).

As soon as the junction temperature exceeds the current reduction temperature threshold  $T_{j(CRT)}$  the output current will be reduced by the device by reducing the IN\_SET reference voltage  $V_{IN\_SET(ref)}$ . This feature avoids LED's flickering during static output overload conditions. Furthermore, it protects LEDs against over temperature, which are mounted thermally close to the device. If the device temperature still increases, the three output currents decrease close to 0 A. As soon as the device cools down the output currents rise again.

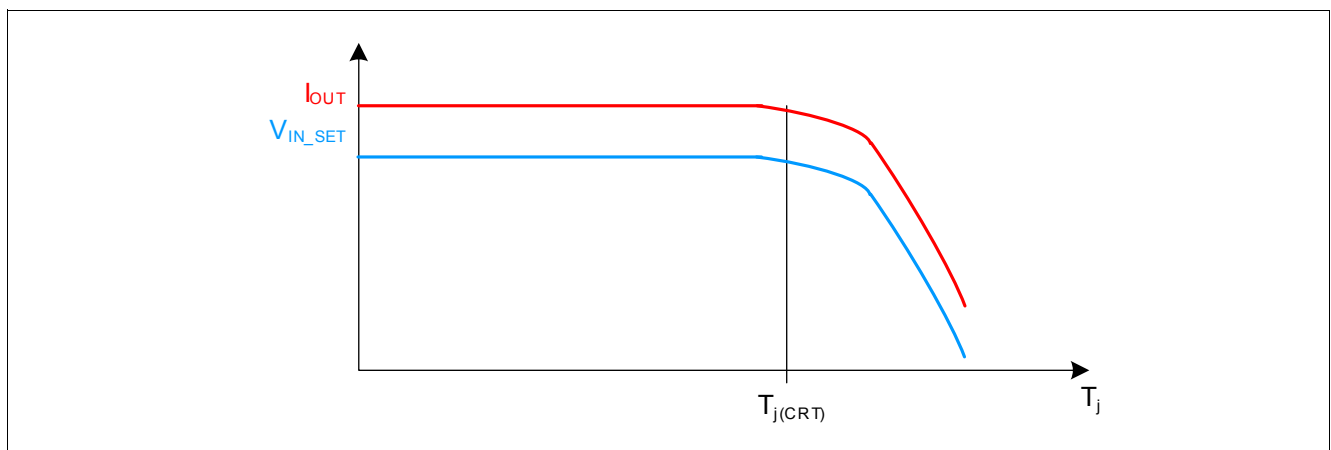

**Figure 15 Output current reduction at high temperature**

*Note: This high temperature output current reduction is realized by reducing the IN\_SET reference voltage (Pos. 7.3.1). In case of very high power loss applied to the device and very high junction temperature the output current may drop down to  $I_{OUTx} = 0$  mA, after a slight cooling down the current increases again.*

#### 8.1.2 Reverse Battery Protection

The TLD1312EL has an integrated reverse battery protection feature. This feature protects the driver IC itself, but also connected LEDs. The output reverse current is limited to  $I_{OUTx(rev)}$  by the reverse battery protection.

Note: Due to the reverse battery protection a reverse protection diode for the light module may be obsolete. In case of high ISO-pulse requirements and only minor protecting components like capacitors a reverse protection diode may be reasonable. The external protection circuit needs to be verified in the application.

## 8.2 Electrical Characteristics Power Stage

### Electrical Characteristics Power Stage

Unless otherwise specified:  $V_S = 5.5\text{ V to }18\text{ V}$ ,  $T_j = -40\text{ °C to }+150\text{ °C}$ ,  $V_{OUTx} = 3.6\text{ V}$ , all voltages with respect to ground, positive current flowing into pin for input pins (I), positive currents flowing out of the I/O and output pins (O) (unless otherwise specified)

Pos.	Parameter	Symbol	Limit Values			Unit	Conditions
			Min.	Typ.	Max.		
8.2.1	Output leakage current	$I_{OUTx(leak)}$	– –	– –	7 3	μA	$V_{EN} = 5.5\text{ V}$ $I_{IN\_SET} = 0\text{ μA}$ $V_{OUTx} = 2.5\text{ V}$ $T_j = 150\text{ °C}$ 1) $T_j = 85\text{ °C}$
8.2.2	Output leakage current in boost over battery setup	- $I_{OUTx(leak,B2B)}$	–	–	50	μA	1) $V_{EN} = 5.5\text{ V}$ $I_{IN\_SET} = 0\text{ μA}$ $V_{OUTx} = V_S = 40\text{ V}$
8.2.3	Reverse output current	$-I_{OUTx(rev)}$	–	–	1	μA	1) $V_S = -16\text{ V}$ Output load: LED with break down voltage < - 0.6 V
8.2.4	Output current accuracy limited temperature range	$k_{LT}$	697 645	750 750	803 855		1) $T_j = 25...115\text{ °C}$ $V_S = 8...18\text{ V}$ $V_{PS} = 2\text{ V}$ $R_{SET} = 6...12\text{ k}\Omega$ $R_{SET} = 30\text{ k}\Omega$
8.2.5	Output current accuracy over temperature	$k_{ALL}$	697 645	750 750	803 855		1) $T_j = -40...115\text{ °C}$ $V_S = 8...18\text{ V}$ $V_{PS} = 2\text{ V}$ $R_{SET} = 6...12\text{ k}\Omega$ $R_{SET} = 30\text{ k}\Omega$
8.2.6	Voltage drop over power stage during current control $V_{PS(CC)} = V_S - V_{OUTx}$	$V_{PS(CC)}$	0.75	–	–	V	1) $V_S = 13.5\text{ V}$ $R_{SET} = 12\text{ k}\Omega$ $I_{OUTx} \geq 90\%$ of $(k_{LT(typ)}/R_{SET})$
8.2.7	Required output voltage for current control	$V_{OUTx(CC)}$	2.3	–	–	V	1) $V_S = 13.5\text{ V}$ $R_{SET} = 12\text{ k}\Omega$ $I_{OUTx} \geq 90\%$ of $(k_{LT(typ)}/R_{SET})$
8.2.8	Maximum output current	$I_{OUT(max)}$	120	–	–	mA	$R_{SET} = 4.7\text{ k}\Omega$ The maximum output current is limited by the thermal conditions. Please refer to <a href="#">Pos. 4.3.1 - Pos. 4.3.3</a>



**Electrical Characteristics Power Stage (cont'd)**

Unless otherwise specified:  $V_S = 5.5\text{ V to }18\text{ V}$ ,  $T_j = -40\text{ °C to }+150\text{ °C}$ ,  $V_{OUTx} = 3.6\text{ V}$ , all voltages with respect to ground, positive current flowing into pin for input pins (I), positive currents flowing out of the I/O and output pins (O) (unless otherwise specified)

Pos.	Parameter	Symbol	Limit Values			Unit	Conditions
			Min.	Typ.	Max.		
8.2.9	PWMI turn on time	$t_{ON(PWMI)}$	–	–	15	$\mu\text{s}$	<sup>2)</sup> $V_S = 13.5\text{ V}$ $R_{SET} = 12\text{ k}\Omega$ PWMI $\rightarrow$ L $I_{OUTx} = 80\%$ of $(k_{LT(typ)}/R_{SET})$
8.2.10	PWMI turn off time	$t_{OFF(PWMI)}$	–	–	10	$\mu\text{s}$	<sup>2)</sup> $V_S = 13.5\text{ V}$ $R_{SET} = 12\text{ k}\Omega$ PWMI $\rightarrow$ H $I_{OUTx} = 20\%$ of $(k_{LT(typ)}/R_{SET})$
8.2.11	IN_SET turn on time	$t_{ON(IN\_SET)}$	–	–	15	$\mu\text{s}$	$V_S = 13.5\text{ V}$ $I_{IN\_SET} = 0 \rightarrow 100\text{ }\mu\text{A}$ $I_{OUTx} = 80\%$ of $(k_{LT(typ)}/R_{SET})$
8.2.12	IN_SET turn off time	$t_{OFF(IN\_SET)}$	–	–	10	$\mu\text{s}$	$V_S = 13.5\text{ V}$ $I_{IN\_SET} = 100 \rightarrow 0\text{ }\mu\text{A}$ $I_{OUTx} = 20\%$ of $(k_{LT(typ)}/R_{SET})$
8.2.13	VS turn on time	$t_{ON(VS)}$	–	–	20	$\mu\text{s}$	<sup>1) 3)</sup> $V_{EN} = 5.5\text{ V}$ $R_{SET} = 12\text{ k}\Omega$ $V_S = 0 \rightarrow 13.5\text{ V}$ $I_{OUTx} = 80\%$ of $(k_{LT(typ)}/R_{SET})$
8.2.14	Current reduction temperature threshold	$T_{j(CRT)}$	–	140	–	$^{\circ}\text{C}$	<sup>1)</sup> $I_{OUTx} = 95\%$ of $(k_{LT(typ)}/R_{SET})$
8.2.15	Output current during current reduction at high temperature	$I_{OUT(CRT)}$	85% of $(k_{LT(typ)}/R_{SET})$	–	–	A	<sup>1)</sup> $R_{SET} = 12\text{ k}\Omega$ $T_j = 150\text{ }^{\circ}\text{C}$

1) Not subject to production test, specified by design

2) see also [Figure 8](#)

3) see also [Figure 6](#)

## 9 Application Information

Note: The following information is given as a hint for the implementation of the device only and shall not be regarded as a description or warranty of a certain functionality, condition or quality of the device.

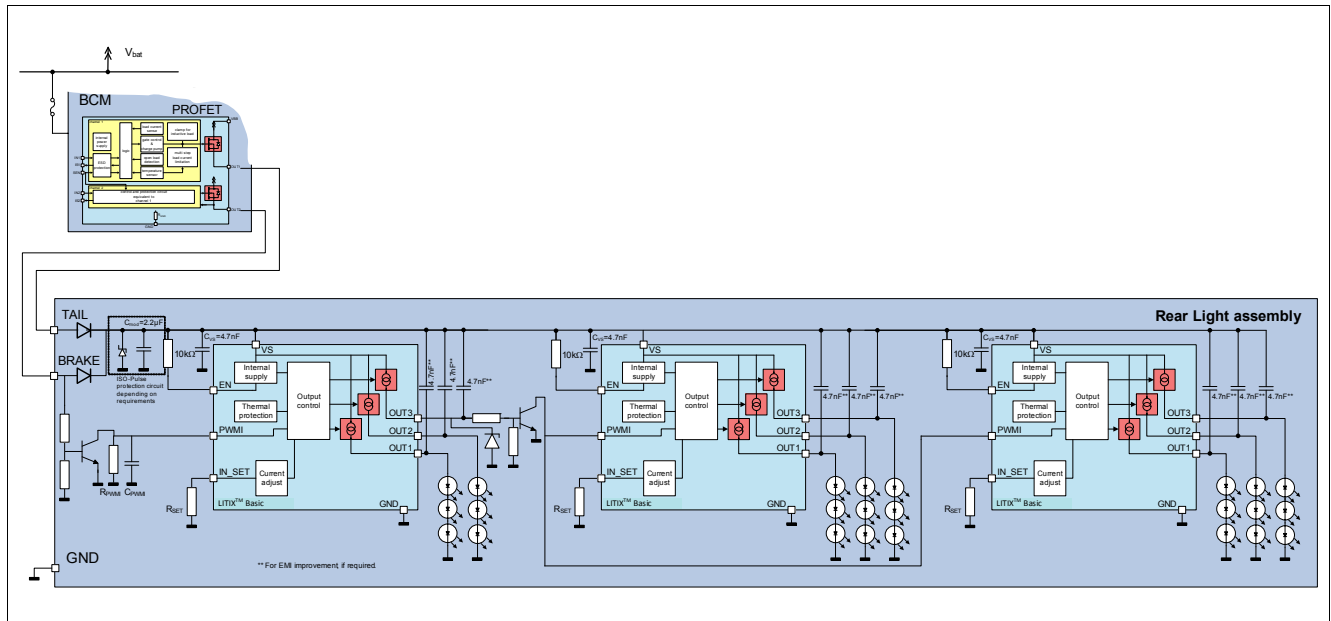

Figure 16 System Diagram internal PWM generation

Note: This is a very simplified example of an application circuit. In case of high ISO-pulse requirements a reverse protection diode may be used for LED protection. The function must be verified in the real application.

### 9.1 Further Application Information

- For further information you may contact <http://www.infineon.com/>

## 10 Package Outlines

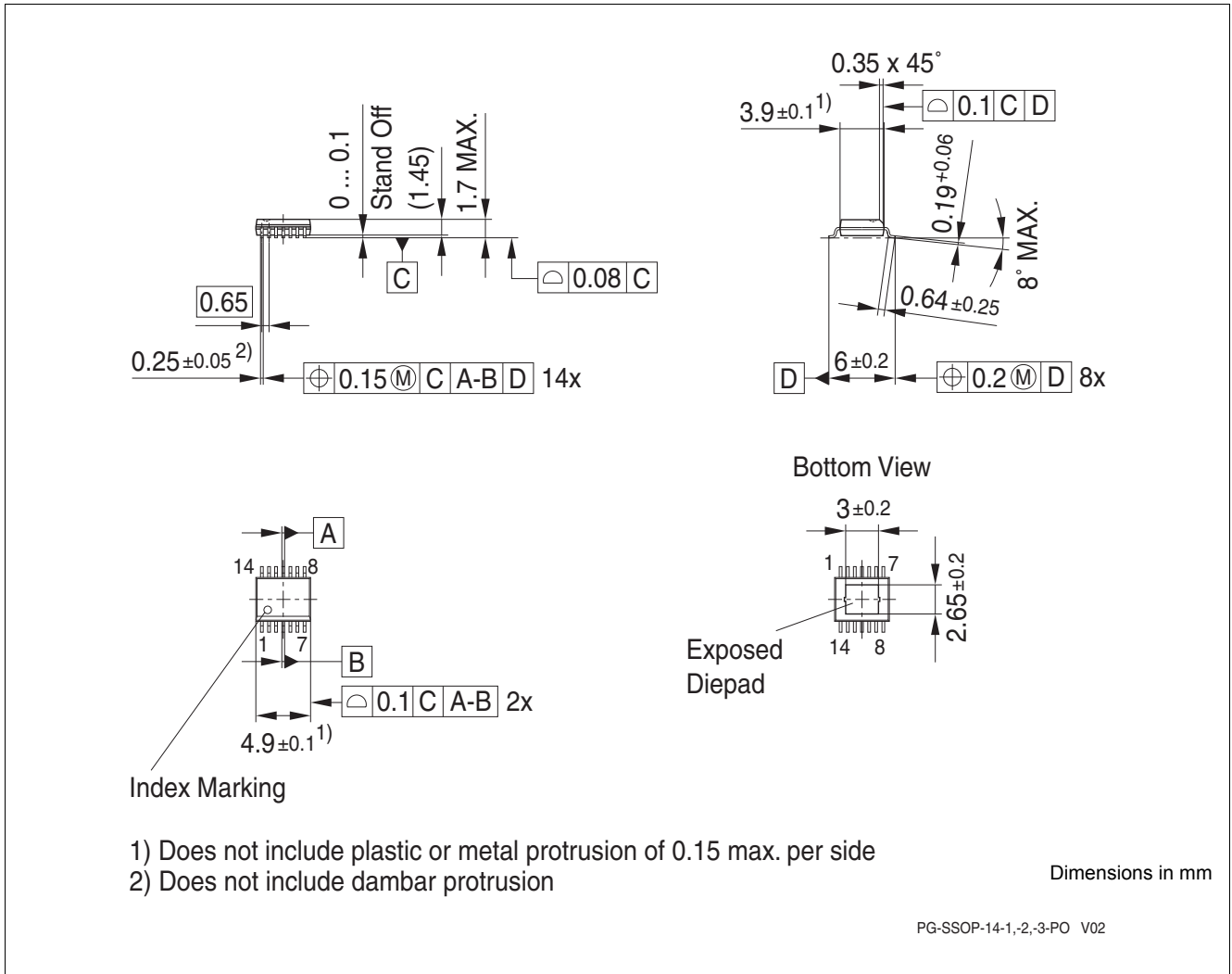

Figure 17 PG-SSOP14

### Green Product (RoHS compliant)

To meet the world-wide customer requirements for environmentally friendly products and to be compliant with government regulations the device is available as a green product. Green products are RoHS-Compliant (i.e. Pb-free finish on leads and suitable for Pb-free soldering according to IPC/JEDEC J-STD-020).

For further information on alternative packages, please visit our website:  
<http://www.infineon.com/packages>.